

Lenovo RackSwitch G8296

# ONIE User Guide

for Lenovo Cloud Network Operating System

**Lenovo**<sup>TM</sup>

**Note:** Before using this information and the product it supports, read the general information in the *Safety information and Environmental Notices* and *User Guide* documents on the *Lenovo Documentation CD*, and the *Warranty Information* document that comes with the product.

Third Edition (January 2018)

© Copyright Lenovo 2018

LIMITED AND RESTRICTED RIGHTS NOTICE: If data or software is delivered pursuant a General Services Administration "GSA" contract, use, reproduction, or disclosure is subject to restrictions set forth in Contract No. GS-35F-05925.

Lenovo and the Lenovo logo are trademarks of Lenovo in the United States, other countries, or both.

---

# Contents

<b>Overview</b> . . . . .	<b>5</b>
<b>Connecting to the G8296</b> . . . . .	<b>6</b>
Switch Unit. . . . .	6
Serial Console Port . . . . .	7
<b>ONIE on the G8296</b> . . . . .	<b>8</b>
Installing the ONIE FoD License Key . . . . .	9
Obtaining the ONIE License Key . . . . .	9
Installing the ONIE License Key on CNOS . . . . .	10
Uninstalling the ONIE License Key on CNOS . . . . .	10
Installing ONIE. . . . .	11
Installing ONIE on CNOS . . . . .	11
Bootting in ONIE Mode . . . . .	13
Bootting in ONIE Install Mode. . . . .	14
Bootting in ONIE Update Mode . . . . .	15
Bootting in ONIE Uninstall Mode . . . . .	15
Bootting in ONIE Rescue Mode . . . . .	16
The Boot Management Menu. . . . .	17
Uninstalling the Lenovo Network OS . . . . .	18
Using ONIE without Lenovo Network OS . . . . .	19
<b>Getting Help and Technical Assistance</b> . . . . .	<b>21</b>
<b>Notices</b> . . . . .	<b>23</b>
Trademarks . . . . .	25
Important Notes . . . . .	26
Recycling Information. . . . .	27
Particulate Contamination . . . . .	28
Telecommunication Regulatory Statement . . . . .	29
Electronic Emission Notices . . . . .	30
Federal Communications Commission (FCC) Statement . . . . .	30
Industry Canada Class A Emission Compliance Statement . . . . .	30
Avis de Conformité à la Réglementation d'Industrie Canada . . . . .	30
Australia and New Zealand Class A Statement . . . . .	30
European Union - Compliance to the Electromagnetic Compatibility Directive	
31	
Germany Class A Statement . . . . .	31
Japan VCCI Class A Statement . . . . .	32
Japan Electronics and Information Technology Industries Association	
(JEITA) Statement. . . . .	32
Korea Communications Commission (KCC) Statement. . . . .	33
Russia Electromagnetic Interference (EMI) Class A statement . . . . .	33
People's Republic of China Class A electronic emission statement . . . . .	33
Taiwan Class A compliance statement . . . . .	33



---

# Overview

The Open Network Install Environment (ONIE) is a small Linux-based operating system that provides an open install environment for network switches without operating systems.

ONIE enables a network switch ecosystem where end-users can choose among different Network Operating Systems (NOS). Practically, ONIE boots on a switch, discovers NOS installer images available on the local network or on a USB drive, copies the chosen image to the switch, and provides an environment where the installer can load the NOS onto the switch.

ONIE is classified as free software, meaning it can be redistributed and/or modified under the terms of version 2 of the GNU General Public License as published by the Free Software Foundation. To read the license, visit the following link:

<https://github.com/opencomputeproject/onie/blob/master/COPYING>

For more details about ONIE, go to [onie.org](http://onie.org).

## Lenovo ONIE Image

To download the Lenovo ONIE image, visit the following website:

<http://support.lenovo.com/>

The ONIE images for the G8296 have the [ONIE] tag in their name, as follows:

Lenovo RackSwitch G8296 [ONIE] Firmware Update v10.x.x.0

## Open-Source ONIE Image

To download an open-source ONIE image, go to the following link:

[https://github.com/lenovo/networking-onie/tree/master/lenovo\\_g8296](https://github.com/lenovo/networking-onie/tree/master/lenovo_g8296)

The image `onie-lenovo_g8296-r0.bin` can be used to install ONIE on a switch that does not already have ONIE installed.

The image `onie-updater-powerpc-lenovo_g8296-r0` can be used to update previously installed ONIE images on a switch.

# Connecting to the G8296

This section describes how to connect to the Lenovo RackSwitch G8296. For more details about the switch and on how to install the switch hardware, consult the *Lenovo RackSwitch G8296 Installation Guide*.

## Switch Unit

The G8296 is a 2U GbE switch and it can be rack-mounted in a horizontal position. The following illustrations show the features on the front and rear panels of the switch:

**Figure 1.** G8296 front panel

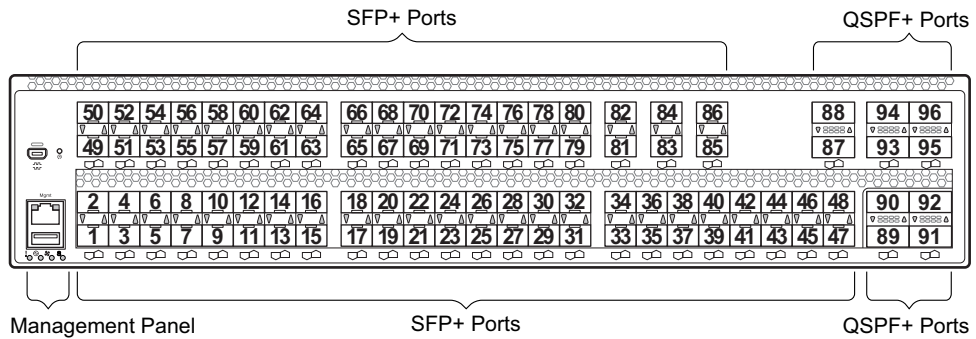

**Figure 2.** G8296 management panel detail

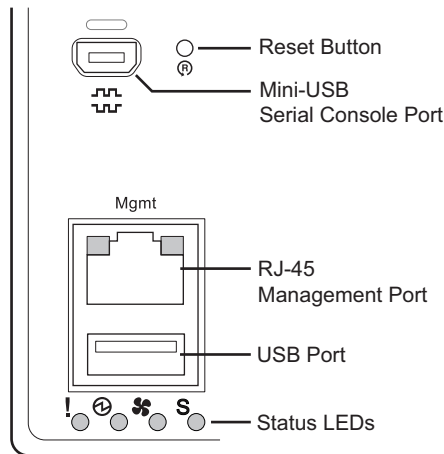

**Figure 3.** G8296 rear panel

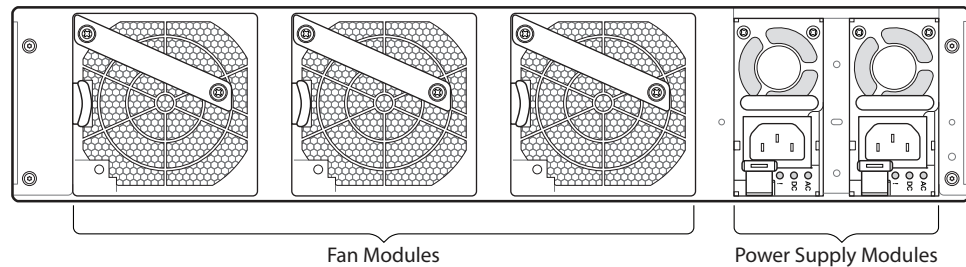

## Serial Console Port

The mini-USB console port on the front management panel is available for switch console management. The port operates using RS-232 serial communications. A compatible console cable kit is included with the switch.

To connect a computer or terminal to the switch using the included kit, first connect the console cable to the mini-USB serial console port on the front panel. Connect one end of the Category 5 patch cable to the RJ45 port on the console cable and the other end of the patch cable to the RJ45-to-DB9 adapter, which connects to the computer or terminal (see the following illustration).

**Figure 4.** Console cable connections

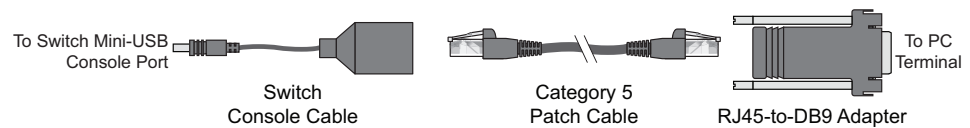

The computer or terminal must run a terminal emulator (for example, SecureCRT, HyperTerminal, or PuTTY). The console port terminal emulation requirements are as follows:

- Default baud rate: 9,600 bps
- Character size: 8 characters
- Parity: none
- Stop bits: 1
- Data bits: 8
- Flow control: none

---

## ONIE on the G8296

The Lenovo RackSwitch G8296 comes out of the box with Lenovo Enterprise Network OS (ENOS) already installed on the switch.

To ensure maximum security, ONIE is not available on the switch by default. To enable the running of ONIE on the switch, you must follow these steps:

1. Download and install a compatible Lenovo Network OS.

You can download the latest Lenovo NOS images from the following link:

<http://support.lenovo.com/>

You can install ONIE on G8296s running:

- *Lenovo Cloud Network OS (CNOS)* version 10.2 or later

**Note:** Check the *Lenovo RackSwitch G8296 Release Notes* associated with each Lenovo Network OS to verify if ONIE is an available feature.

For details on how to upgrade the switch operating system from ENOS to CNOS, see the *Lenovo RackSwitch G8296 Release Notes for Lenovo Cloud Network Operating System*.

2. Obtain and install an ONIE Feature on Demand (FoD) license key.

For details on how to acquire and install the ONIE FoD license key on the switch, see [“Installing the ONIE FoD License Key”](#) on page 9.

3. Download and install an ONIE image.

For details on how to install ONIE on the switch, see [“Installing ONIE”](#) on page 11.



---

## Installing the ONIE FoD License Key

ONIE is not installed by default and it can be activated only using a Feature on Demand (FoD) license key. The process of obtaining and installing a FoD license key is described in the following pages.

### Obtaining the ONIE License Key

The ONIE license key or activation key can be acquired using the *Lenovo Features on Demand* (FoD) website:

<http://fod.lenovo.com/lkms/>

You can also use the website to review and manage the license, and to obtain additional help if required.

**Note:** An ID and password are required to log into the FoD website. If you do not have an ID, you can register at the website.

The ONIE FoD license key is provided as a file that must be downloaded to the switch. To obtain an activation key, acquire an Authorization Code from the *Lenovo Features on Demand* website.

To acquire the Authorization Code, you need to provide the unique ID (UID) of the specific switch where the ONIE license key is to be installed. The UID is the last 12 characters of the switch serial number. This serial number is located on the Part Number (PN) label.

You can also view the UID of a switch using the following command:

```
G8296> display license host-id  
System serial number: Y052MV4CR026
```

Once the ONIE license key file is acquired from the *Lenovo Features on Demand* website, it must be installed on the G8296.

## Installing the ONIE License Key on CNOS

The following example depicts the use of the G8296 Command Line Interface (CLI) running *Cloud NOS (CNOS)* to install the ONIE license key.

1. Log into the G8296 and enter Global Configuration command mode:

```
G8296> enable
G8296# configure device
G8296(config)#
```

2. You can install the license key by copying it from a remote server or a USB device:

- remote FTP, SCP, SFTP, or TFTP server:

```
G8296(config)# license install {ftp|scp|sftp|tftp} <server IP address and
file path> vrf management
```

For example, using a TFTP server:

```
G8296(config)# license install tftp tftp://10.120.33.12/fod-keys/fodEE3
vrf management
```

- USB device:

```
G8296(config)# license install usb1 <file path>
```

For example:

```
G8296(config)# license install usb1 fod-keys/fodEE3
```

The license key is now successfully installed on the switch.

3. To view installed license keys, use the following command:

```
G8296> display license brief
```

## Uninstalling the ONIE License Key on CNOS

To remove the ONIE license key from the switch, use the following command:

```
G8296(config)# no license install <license file>
```

For example:

```
G8296(config)# no license install fodEE3
```

**Note:** When removing the ONIE license key from the switch, the ONIE software image is also removed.

---

## Installing ONIE

Only after you successfully install the appropriate FoD license key, you are able to install ONIE on the switch. For more details, see [“Installing the ONIE FoD License Key” on page 9](#).

### Installing ONIE on CNOS

To install ONIE on the switch running *Cloud NOS*, use the following steps:

**Note:** The commands used to install ONIE on the switch display an error if the ONIE license key is not installed.

1. Download an ONIE image for the switch from the following link:

<http://support.lenovo.com/>

For CNOS, the ONIE image is called `Lenovo RackSwitch G8296 [ONIE] v10.x.x.0`.

2. Upload the ONIE image to a local server or a USB drive.
3. Connect to the switch using the mini-USB serial console port. For more details, see [“Connecting to the G8296” on page 6](#).
4. After connecting to the switch, enter Privileged EXEC configuration mode:

```
G8296> enable
G8296#
```

5. Use one of the following commands to copy the ONIE image:
  - using FTP, SCP, SFTP, or TFTP:
    - `cp ftp <FTP URL> system-image onie [vrf management]`
    - `cp scp <SCP URL> system-image onie [vrf management]`
    - `cp sftp <SFTP URL> system-image onie [vrf management]`
    - `cp tftp <TFTP URL> system-image onie [vrf management]`
  - using a USB drive:
    - `cp usb1 <file path> system-image onie [vrf management]`

Following is an example using the **cp tftp** command:

```
G8296# cp tftp tftp://10.72.97.98/onie/G8296-CNOS-10.2.2.0_ONIE.imgs  
system-image onie vrf management  
  
Confirm download operation? (y/n) [n] y  
Download in progress  
...  
Copy Success  
  
Install image...This takes about 90 seconds. Please wait  
Valid image detected.  
Check image signature succeeded  
Extracting image: 100%  
Installing ONIE:  
Updating flash: 100%  
Updating ONIE eeprom with manufacturing fields...  
ONIE image installation succeeded.  
ONIE image now contains Software Version 10.2.2.0
```

6. To check if the ONIE image is successfully installed on the switch, use the following command:

```
G8296# display boot  
  
Current FLASH software:  
  active image: version 10.2.2.0  
  standby image: empty  
  Uboot: version 10.2.2.0  
  ONIE: version 10.2.2.0  
Currently set to boot software active image  
Currently scheduled reboot time: none  
Current port mode: default mode
```

In the command output, the current ONIE image installed on the switch is displayed under the **Current FLASH software** section.

---

## Booting in ONIE Mode

After you activate and install an ONIE image, you can boot the switch in ONIE mode. ONIE offers four modes for booting, each providing a different operation:

- ONIE install mode
- ONIE rescue mode
- ONIE uninstall mode
- ONIE update mode

There are two ways to boot the switch in an ONIE mode:

- using the Command Line Interface (CLI):
  - **startup image onie-image install**
  - **startup image onie-image rescue**
  - **startup image onie-image uninstall**
  - **startup image onie-image update**
- using the Boot Management Menu (for more details, see [“The Boot Management Menu” on page 17](#))

**Note:** For CNOS, the CLI commands for booting in different ONIE modes display an error if the ONIE license key is not installed on the switch. To install the ONIE license key, see [“Installing the ONIE FoD License Key” on page 9](#).

The following pages describe the four ONIE modes and how the CLI commands can be used to boot the switch in each mode.

## Booting in ONIE Install Mode

This mode is used to install a NOS using ONIE. The ONIE install mode boots the ONIE kernel and file-system and executes the ONIE discovery process. The discovery process uses a number of different mechanisms to find a NOS installer program.

Once a NOS installer is found, it is downloaded and executed. The installer loads the Network OS on the switch, updates required ONIE environment variables, and reboots the switch.

The switch now runs its newly installed Network OS and behaves like a regular switch. The user can, at any point, reboot and run the ONIE installer again to install another Network OS.

The Lenovo ONIE installer image, which installs the different Lenovo Network Operating Systems, is called `onie-installer-powerpc-lenovo_g8296-r0`, and it is available at the following link:

<http://support.lenovo.com/>

To boot the switch in ONIE install mode on the next reload, use the following command from the switch CLI:

```
G8296(config)# startup image onie-image install
```

To check which ONIE mode the switch is configured to boot in, use the following command from the switch CLI:

```
G8296# display boot

Current ZTP State: Enable
Current FLASH software:
  active image: version 10.2.1.0
  standby image: version 0.0.0.0
Uboot: version 10.2.1.0
ONIE: version 10.2.1.0
Currently set to boot ONIE install mode
Currently scheduled reboot time: none
Current port mode: default mode
```

## Booting in ONIE Update Mode

ONIE update mode installs a new version of ONIE on the switch, including the boot loader and the Linux kernel. It works similarly to the ONIE install mode, except the discovery process searches for an ONIE image instead, and not a NOS image.

### Notes:

- This only upgrades the ONIE partition on the switch and does not affect the NOS image.

The ONIE updater image is called  
onie-updater-powerpc-lenovo\_g8296-r0.

- This also installs a different version of the ONIE boot loader, which does not support running Lenovo Network OS. If you wish to boot Lenovo NOS, you have to re-install it by using ONIE Install mode (for more details, see [“Booting in ONIE Install Mode” on page 14](#)).

To boot the switch in ONIE update mode on the next reload, use the following command from the switch CLI:

```
G8296(config)# startup image onie-image update
```

**Note:** Upon reloading after the update process is completed, the switch is not able to load the Lenovo Network OS, booting into ONIE Install mode instead. To access the console port at this point, you must change the default baud rate of the terminal emulator to 115,200 bps.

## Booting in ONIE Uninstall Mode

This mode is used to uninstall a NOS using ONIE. The ONIE uninstall mode boots the ONIE kernel and deletes the NOS image running on the switch. After the uninstall is complete, the switch automatically reloads and boots into ONIE install mode.

To boot the switch in ONIE uninstall mode on the next reload, use the following command from the switch CLI:

```
G8296(config)# startup image onie-image uninstall
```

**Note:** The following warning is displayed after choosing ONIE uninstall mode. You are prompted for confirmation:

```
WARNING: Booting ONIE in uninstall mode will completely uninstall the
operating system!
Only the ONIE image will be preserved.
Are you sure you want the next boot to uninstall the OS? (y/n)
```

Once you confirm, the switch boots in ONIE uninstall mode on the next reload. For more details, see [“Uninstalling the Lenovo Network OS” on page 18](#).

## Booting in ONIE Rescue Mode

ONIE rescue mode is useful when trying to recover from a broken NOS image. It works similarly to the ONIE install mode, except the ONIE discovery process is disabled. ONIE will not try to find and install a NOS image. This allows for the troubleshooting of the system.

To boot the switch in ONIE rescue mode on the next reload, use the following command from the switch CLI:

```
G8296(config)# startup image onie-image rescue
```



---

## The Boot Management Menu

The Boot Management menu is another way to access ONIE and configure the switch to boot in different ONIE modes.

You can interrupt the startup process of the switch and enter the Boot Management menu from the serial console port. When the system displays the following message, press **Shift + B**. The Boot Management menu appears.

```
The system is going down for reboot NOW!
...
Press shift-B for startup menu or shift-R for recovery mode: ..
Running Startup Menu
...
Boot Management Menu
    I - Change booting image
    R - Boot in recovery mode (tftp and xmodem download of images to
recover switch)
    P - Password reset
    O - ONIE submenu
    Q - Reboot
    E - Exit
Please choose your menu option:
```

**Note:** For CNOS, the submenu is available, but executing any of its options results in an error, unless the ONIE license key is installed. For more details, see [“Installing the ONIE FoD License Key” on page 9](#).

To enter the ONIE submenu, press **O**.

```
ONIE Menu
    I - Startup ONIE OS installer
    N - Startup NOS mode (system default)
    R - Startup ONIE rescue mode
    U - Startup ONIE self update mode
    D - Startup ONIE OS uninstaller
    E - Exit ONIE menu

Option? :
```

The ONIE submenu allows you to perform the following actions:

- To boot the switch in ONIE Install mode, press **I**. For more details, see [“Booting in ONIE Install Mode” on page 14](#).
- To boot the switch in ONIE Rescue mode, press **R**. For more details, see [“Booting in ONIE Rescue Mode” on page 16](#).
- To boot the switch in ONIE Update mode, press **U**. For more details, see [“Booting in ONIE Update Mode” on page 15](#).
- To boot the switch in ONIE Uninstall mode, press **D**. For more details, see [“Booting in ONIE Uninstall Mode” on page 15](#).
- To boot the switch using the installed NOS image, press **N**.
- To exit the ONIE submenu and return to the Boot Management Menu, press **E**.

---

## Uninstalling the Lenovo Network OS

If you wish to run another network operating system (NOS), you can uninstall the *Lenovo Network OS* by using the ONIE Uninstall mode. For more details, see [“Booting in ONIE Uninstall Mode” on page 15](#).

### Notes:

- If ONIE is not installed on the switch, you must first install an ONIE FoD license key and then set up the software on the networking device. For more details, see [“Installing the ONIE FoD License Key” on page 9](#) and [“Installing ONIE” on page 11](#).
- Once you uninstall the *Lenovo Network OS* from the network device, see [“Using ONIE without Lenovo Network OS” on page 19](#).

After booting in ONIE Uninstall mode, the following is displayed:

```
Loading Open Network Install Environment ...
Platform: -lenovo_g8296-r0
Version : lenovo-internal
...

discover: Uninstall mode detected. Running uninstaller.
Erasing u-boot environment NOR flash region
Erasing 128 Kibyte @ 20000 - 100% complete.
Erasing internal mass storage device: /dev/mmcblk0 (7631MB)
  Percent complete: 100%
Erase complete.
Uninstall complete. Rebooting...
discover: Uninstall mode detected. No discover stopped.
Stopping: dropbear ssh daemon... done.
Stopping: telnetd... done.
Stopping: syslogd... done.
Info: Unmounting kernel filesystems
The system is going down NOW!
Sent SIGTERM to all processes
Sent SIGKILL to all processes
Requesting system reboot
Restarting system.
...
discover: installer mode detected. Running installer.
Starting: discover... done.

Please press Enter to activate this console. Info: eth0: Checking
link... up.
Info: Trying DHCPv4 on interface: eth0
Warning: Unable to configure interface using DHCPv4: eth0
ONIE: Using default IPv4 addr: eth0: 192.168.3.10/24
ONIE: Using link-local IPv4 addr: eth0: 169.254.166.99/16
ONIE: Starting ONIE Service Discovery
```

Once the NOS uninstall process is complete, the switch is reloaded and configured to boot in ONIE Install mode.

---

## Using ONIE without Lenovo Network OS

If you remove the Lenovo Network OS from the switch by using ONIE Uninstall mode, we recommend that you consult the official documentation from the ONIE website:

<https://github.com/opencomputeproject/onie/wiki/Quick-Start-Guide>

If you run into trouble with an ONIE-based installation, follow the suggestions from the ONIE website:

<https://github.com/opencomputeproject/onie/wiki/Quick-Start-Guide#debugging-an-installation>



---

## Appendix A. Getting Help and Technical Assistance

If you need help, service, or technical assistance or just want more information about Lenovo products, you will find a wide variety of sources available from Lenovo to assist you.

Use this information to obtain additional information about Lenovo and Lenovo products, and determine what to do if you experience a problem with your Lenovo system or optional device.

**Note:** This section includes references to IBM web sites and information about obtaining service. IBM is Lenovo's preferred service provider for the System x, Flex System, and NeXtScale System products.

Before you call, make sure that you have taken these steps to try to solve the problem yourself.

If you believe that you require warranty service for your Lenovo product, the service technicians will be able to assist you more efficiently if you prepare before you call.

- Check all cables to make sure that they are connected.
- Check the power switches to make sure that the system and any optional devices are turned on.
- Check for updated software, firmware, and operating-system device drivers for your Lenovo product. The Lenovo Warranty terms and conditions state that you, the owner of the Lenovo product, are responsible for maintaining and updating all software and firmware for the product (unless it is covered by an additional maintenance contract). Your service technician will request that you upgrade your software and firmware if the problem has a documented solution within a software upgrade.
- If you have installed new hardware or software in your environment, check the [Lenovo Support portal](#) to make sure that the hardware and software is supported by your product., and where you can check for information to help you solve the problem.
- Gather the following information to provide to the service technician. This data will help the service technician quickly provide a solution to your problem and ensure that you receive the level of service for which you might have contracted.
  - Hardware and Software Maintenance agreement contract numbers, if applicable
  - Machine type number (if applicable—Lenovo 4-digit machine identifier)
  - Model number
  - Serial number
  - Current system UEFI and firmware levels
  - Other pertinent information such as error messages and logs
- Start the process of determining a solution to your problem by making the pertinent information available to the service technicians. The IBM service technicians can start working on your solution as soon as you have completed and submitted an Electronic Service Request.

You can solve many problems without outside assistance by following the troubleshooting procedures that Lenovo provides in the online help or in the Lenovo product documentation. The Lenovo product documentation also describes the diagnostic tests that you can perform. The documentation for most systems, operating systems, and programs contains troubleshooting procedures and explanations of error messages and error codes. If you suspect a software problem, see the documentation for the operating system or program.

---

## Appendix B. Notices

Lenovo may not offer the products, services, or features discussed in this document in all countries. Consult your local Lenovo representative for information on the products and services currently available in your area.

Any reference to a Lenovo product, program, or service is not intended to state or imply that only that Lenovo product, program, or service may be used. Any functionally equivalent product, program, or service that does not infringe any Lenovo intellectual property right may be used instead. However, it is the user's responsibility to evaluate and verify the operation of any other product, program, or service.

Lenovo may have patents or pending patent applications covering subject matter described in this document. The furnishing of this document does not give you any license to these patents. You can send license inquiries, in writing, to:

Lenovo (United States), Inc.  
1009 Think Place - Building One  
Morrisville, NC 27560  
U.S.A.

Attention: Lenovo Director of Licensing

LENOVO PROVIDES THIS PUBLICATION "AS IS" WITHOUT WARRANTY OF ANY KIND, EITHER EXPRESS OR IMPLIED, INCLUDING, BUT NOT LIMITED TO, THE IMPLIED WARRANTIES OF NON-INFRINGEMENT, MERCHANTABILITY OR FITNESS FOR A PARTICULAR PURPOSE. Some jurisdictions do not allow disclaimer of express or implied warranties in certain transactions, therefore, this statement may not apply to you.

This information could include technical inaccuracies or typographical errors. Changes are periodically made to the information herein; these changes will be incorporated in new editions of the publication. Lenovo may make improvements and/or changes in the product(s) and/or the program(s) described in this publication at any time without notice.

The products described in this document are not intended for use in implantation or other life support applications where malfunction may result in injury or death to persons. The information contained in this document does not affect or change Lenovo product specifications or warranties.

Nothing in this document shall operate as an express or implied license or indemnity under the intellectual property rights of Lenovo or third parties. All information contained in this document was obtained in specific environments and is presented as an illustration. The result obtained in other operating environments may vary.

Lenovo may use or distribute any of the information you supply in any way it believes appropriate without incurring any obligation to you.

Any references in this publication to non-Lenovo Web sites are provided for convenience only and do not in any manner serve as an endorsement of those Web sites. The materials at those Web sites are not part of the materials for this Lenovo product, and use of those Web sites is at your own risk.

Any performance data contained herein was determined in a controlled environment. Therefore, the result obtained in other operating environments may vary significantly. Some measurements may have been made on development-level systems and there is no guarantee that these measurements will be the same on generally available systems. Furthermore, some measurements may have been estimated through extrapolation. Actual results may vary. Users of this document should verify the applicable data for their specific environment.



---

## Trademarks

Lenovo, the Lenovo logo, Flex System, System x, NeXtScale System, and X-Architecture are trademarks of Lenovo in the United States, other countries, or both.

Intel and Intel Xeon are trademarks of Intel Corporation in the United States, other countries, or both.

Internet Explorer, Microsoft, and Windows are trademarks of the Microsoft group of companies.

Linux is a registered trademark of Linus Torvalds.

Other company, product, or service names may be trademarks or service marks of others.

---

## Important Notes

Processor speed indicates the internal clock speed of the microprocessor; other factors also affect application performance.

CD or DVD drive speed is the variable read rate. Actual speeds vary and are often less than the possible maximum.

When referring to processor storage, real and virtual storage, or channel volume, KB stands for 1,024 bytes, MB stands for 1,048,576 bytes and GB stands for 1,073,741,824 bytes.

When referring to hard disk drive capacity or communications volume, MB stands for 1,000,000 bytes and GB stands for 1,000,000,000 bytes. Total user-accessible capacity can vary depending on operating environments.

Maximum internal hard disk drive capacities assume the replacement of any standard hard disk drives and population of all hard-disk-drive bays with the largest currently supported drives that are available from Lenovo.

Maximum memory might require replacement of the standard memory with an optional memory module.

Each solid-state memory cell has an intrinsic, finite number of write cycles that the cell can incur. Therefore, a solid-state device has a maximum number of write cycles that it can be subjected to, expressed as total bytes written (TBW). A device that has exceeded this limit might fail to respond to system-generated commands or might be incapable of being written to. Lenovo is not responsible for replacement of a device that has exceeded its maximum guaranteed number of program/erase cycles, as documented in the Official Published Specifications for the device.

Lenovo makes no representations or warranties with respect to non-Lenovo products. Support (if any) for the non-Lenovo products is provided by the third party, not Lenovo.

Some software might differ from its retail version (if available) and might not include user manuals or all program functionality.

---

## Recycling Information

Lenovo encourages owners of information technology (IT) equipment to responsibly recycle their equipment when it is no longer needed. Lenovo offers a variety of programs and services to assist equipment owners in recycling their IT products. For information on recycling Lenovo products, go to:

<http://www.lenovo.com/recycling>

## Particulate Contamination

**Attention:** Airborne particulates (including metal flakes or particles) and reactive gases acting alone or in combination with other environmental factors such as humidity or temperature might pose a risk to the device that is described in this document.

Risks that are posed by the presence of excessive particulate levels or concentrations of harmful gases include damage that might cause the device to malfunction or cease functioning altogether. This specification sets forth limits for particulates and gases that are intended to avoid such damage. The limits must not be viewed or used as definitive limits, because numerous other factors, such as temperature or moisture content of the air, can influence the impact of particulates or environmental corrosives and gaseous contaminant transfer. In the absence of specific limits that are set forth in this document, you must implement practices that maintain particulate and gas levels that are consistent with the protection of human health and safety. If Lenovo determines that the levels of particulates or gases in your environment have caused damage to the device, Lenovo may condition provision of repair or replacement of devices or parts on implementation of appropriate remedial measures to mitigate such environmental contamination. Implementation of such remedial measures is a customer responsibility..

Contaminant	Limits
Particulate	<ul style="list-style-type: none"> <li>The room air must be continuously filtered with 40% atmospheric dust spot efficiency (MERV 9) according to ASHRAE Standard 52.2<sup>1</sup>.</li> <li>Air that enters a data center must be filtered to 99.97% efficiency or greater, using high-efficiency particulate air (HEPA) filters that meet MIL-STD-282.</li> <li>The deliquescent relative humidity of the particulate contamination must be more than 60%<sup>2</sup>.</li> <li>The room must be free of conductive contamination such as zinc whiskers.</li> </ul>
Gaseous	<ul style="list-style-type: none"> <li>Copper: Class G1 as per ANSI/ISA 71.04-1985<sup>3</sup></li> <li>Silver: Corrosion rate of less than 300 Å in 30 days</li> </ul>

<sup>1</sup> ASHRAE 52.2-2008 - *Method of Testing General Ventilation Air-Cleaning Devices for Removal Efficiency by Particle Size*. Atlanta: American Society of Heating, Refrigerating and Air-Conditioning Engineers, Inc.

<sup>2</sup> The deliquescent relative humidity of particulate contamination is the relative humidity at which the dust absorbs enough water to become wet and promote ionic conduction.

<sup>3</sup> ANSI/ISA-71.04-1985. *Environmental conditions for process measurement and control systems: Airborne contaminants*. Instrument Society of America, Research Triangle Park, North Carolina, U.S.A.

---

## Telecommunication Regulatory Statement

This product may not be certified in your country for connection by any means whatsoever to interfaces of public telecommunications networks. Further certification may be required by law prior to making any such connection. Contact a Lenovo representative or reseller for any questions.

---

## Electronic Emission Notices

When you attach a monitor to the equipment, you must use the designated monitor cable and any interference suppression devices that are supplied with the monitor.

### Federal Communications Commission (FCC) Statement

**Note:** This equipment has been tested and found to comply with the limits for a Class A digital device, pursuant to Part 15 of the FCC Rules. These limits are designed to provide reasonable protection against harmful interference when the equipment is operated in a commercial environment. This equipment generates, uses, and can radiate radio frequency energy and, if not installed and used in accordance with the instruction manual, may cause harmful interference to radio communications. Operation of this equipment in a residential area is likely to cause harmful interference, in which case the user will be required to correct the interference at his own expense.

Properly shielded and grounded cables and connectors must be used to meet FCC emission limits. Lenovo is not responsible for any radio or television interference caused by using other than recommended cables and connectors or by unauthorized changes or modifications to this equipment. Unauthorized changes or modifications could void the user's authority to operate the equipment.

This device complies with Part 15 of the FCC Rules. Operation is subject to the following two conditions: (1) this device may not cause harmful interference, and (2) this device must accept any interference received, including interference that might cause undesired operation.

### Industry Canada Class A Emission Compliance Statement

This Class A digital apparatus complies with Canadian ICES-003.

### Avis de Conformité à la Réglementation d'Industrie Canada

Cet appareil numérique de la classe A est conforme à la norme NMB-003 du Canada.

### Australia and New Zealand Class A Statement

**Attention:** This is a Class A product. In a domestic environment this product may cause radio interference in which case the user may be required to take adequate measures.

## European Union - Compliance to the Electromagnetic Compatibility Directive

This product is in conformity with the protection requirements of EU Council Directive 2004/108/EC (until April 19, 2016) and EU Council Directive 2014/30/EU (from April 20, 2016) on the approximation of the laws of the Member States relating to electromagnetic compatibility. Lenovo cannot accept responsibility for any failure to satisfy the protection requirements resulting from a non-recommended modification of the product, including the installation of option cards from other manufacturers.

This product has been tested and found to comply with the limits for Class A equipment according to European Standards harmonized in the Directives in compliance. The limits for Class A equipment were derived for commercial and industrial environments to provide reasonable protection against interference with licensed communication equipment.

 Lenovo, Einsteinova 21, 851 01 Bratislava, Slovakia

**Warning:** This is a Class A product. In a domestic environment this product may cause radio interference in which case the user may be required to take adequate measures.

## Germany Class A Statement

**Deutschsprachiger EU Hinweis:**

### **Hinweis für Geräte der Klasse A EU-Richtlinie zur Elektromagnetischen Verträglichkeit**

Dieses Produkt entspricht den Schutzanforderungen der EU-Richtlinie 2014/30/EU (früher 2004/108/EC) zur Angleichung der Rechtsvorschriften über die elektromagnetische Verträglichkeit in den EU-Mitgliedsstaaten und hält die Grenzwerte der Klasse A der Norm gemäß Richtlinie.

Um dieses sicherzustellen, sind die Geräte wie in den Handbüchern beschrieben zu installieren und zu betreiben. Des Weiteren dürfen auch nur von der Lenovo empfohlene Kabel angeschlossen werden. Lenovo übernimmt keine Verantwortung für die Einhaltung der Schutzanforderungen, wenn das Produkt ohne Zustimmung der Lenovo verändert bzw. wenn Erweiterungskomponenten von Fremdherstellern ohne Empfehlung der Lenovo gesteckt/eingebaut werden.

**Deutschland:**

### **Einhaltung des Gesetzes über die elektromagnetische Verträglichkeit von Betriebsmitteln**

Dieses Produkt entspricht dem „Gesetz über die elektromagnetische Verträglichkeit von Betriebsmitteln“ EMVG (früher „Gesetz über die elektromagnetische Verträglichkeit von Geräten“). Dies ist die Umsetzung der EU-Richtlinie 2014/30/EU (früher 2004/108/EC) in der Bundesrepublik Deutschland.

**Zulassungsbescheinigung laut dem Deutschen Gesetz über die elektromagnetische Verträglichkeit von Betriebsmitteln, EMVG vom 20. Juli 2007 (früher Gesetz über die elektromagnetische Verträglichkeit von Geräten), bzw. der EMV EU Richtlinie 2014/30/EU (früher 2004/108/EC), für Geräte der Klasse A.**

Dieses Gerät ist berechtigt, in Übereinstimmung mit dem Deutschen EMVG das EG-Konformitätszeichen - CE - zu führen. Verantwortlich für die Konformitätserklärung nach Paragraf 5 des EMVG ist die Lenovo (Deutschland) GmbH, Meitnerstr. 9, D-70563 Stuttgart.

Informationen in Hinsicht EMVG Paragraf 4 Abs. (1) 4:

**Das Gerät erfüllt die Schutzanforderungen nach EN 55024 und EN 55022 Klasse A.**

Nach der EN 55022: „Dies ist eine Einrichtung der Klasse A. Diese Einrichtung kann im Wohnbereich Funkstörungen verursachen; in diesem Fall kann vom Betreiber verlangt werden, angemessene Maßnahmen durchzuführen und dafür aufzukommen.“

Nach dem EMVG: „Geräte dürfen an Orten, für die sie nicht ausreichend entstört sind, nur mit besonderer Genehmigung des Bundesministers für Post und Telekommunikation oder des Bundesamtes für Post und Telekommunikation betrieben werden. Die Genehmigung wird erteilt, wenn keine elektromagnetischen Störungen zu erwarten sind.“ (Auszug aus dem EMVG, Paragraph 3, Abs. 4). Dieses Genehmigungsverfahren ist nach Paragraph 9 EMVG in Verbindung mit der entsprechenden Kostenverordnung (Amtsblatt 14/93) kostenpflichtig.

Anmerkung: Um die Einhaltung des EMVG sicherzustellen sind die Geräte, wie in den Handbüchern angegeben, zu installieren und zu betreiben.

## Japan VCCI Class A Statement

この装置は、クラス A 情報技術装置です。この装置を家庭環境で使用する  
と電波妨害を引き起こすことがあります。この場合には使用者が適切な対策  
を講ずるよう要求されることがあります。 VCCI-A

This is a Class A product based on the standard of the Voluntary Control Council for Interference (VCCI). If this equipment is used in a domestic environment, radio interference may occur, in which case the user may be required to take corrective actions.

## Japan Electronics and Information Technology Industries Association (JEITA) Statement

高調波ガイドライン適合品

Japan Electronics and Information Technology Industries Association (JEITA)  
Confirmed Harmonics Guidelines (products less than or equal to 20 A per phase)

高調波ガイドライン準用品

Japan Electronics and Information Technology Industries Association (JEITA)  
Confirmed Harmonics Guidelines with Modifications (products greater than 20 A per phase).



## Korea Communications Commission (KCC) Statement

이 기기는 업무용(A급)으로 전자파적합기기로  
서 판매자 또는 사용자는 이 점을 주의하시기  
바라며, 가정외의 지역에서 사용하는 것을 목  
적으로 합니다.

This is electromagnetic wave compatibility equipment for business (Type A). Sellers and users need to pay attention to it. This is for any areas other than home.

## Russia Electromagnetic Interference (EMI) Class A statement

ВНИМАНИЕ! Настоящее изделие относится к классу А.  
В жилых помещениях оно может создавать радиопомехи, для  
снижения которых необходимы дополнительные меры

## People's Republic of China Class A electronic emission statement

中华人民共和国“A类”警告声明

声明

此为A级产品，在生活环境中，该产品可能会造成无线电干扰。在这种情况下，可能需要用户对其干扰采取切实可行的措施。

## Taiwan Class A compliance statement

警告使用者：  
這是甲類的資訊產品，在  
居住的環境中使用時，可  
能會造成射頻干擾，在這  
種情況下，使用者會被要  
求採取某些適當的對策。

