



# Lenovo Storage DX8200 Installation and Service Guide



**Machine Type:** 5120, 5128, 5133, 5135, 5136, and 5139

**Note**

Before using this information and the product it supports, read the general information in Appendix D “Getting help and technical assistance” on page 1149, Appendix E “Notices” on page 1153, the *Warranty Information* document, and the *Safety Information* and *Environmental Notices and User Guide* documents on the *Documentation* CD.

**First Edition (August 2016)**

**© Copyright Lenovo 2016.**

LIMITED AND RESTRICTED RIGHTS NOTICE: If data or software is delivered pursuant to a General Services Administration “GSA” contract, use, reproduction, or disclosure is subject to restrictions set forth in Contract No. GS-35F-05925.

---

# Contents

<b>Safety</b> . . . . .	<b>v</b>
Safety statements . . . . .	vi

<b>Chapter 1. The Lenovo Storage DX8200 server</b> . . . . .	<b>1</b>
The Documentation CD . . . . .	4
Hardware and software requirements . . . . .	4
The Documentation CD . . . . .	5
Related documentation . . . . .	5
Notices and statements in this document . . . . .	6
Server features and specifications . . . . .	6
Rail and supported rack specifications . . . . .	12
What your server offers . . . . .	13
Reliability, availability, and serviceability . . . . .	16
Server controls, LEDs, and power . . . . .	18
Front view . . . . .	18
Operator information panel . . . . .	20
LCD system information display panel . . . . .	21
Rear view . . . . .	24
Server components . . . . .	27
Server power features . . . . .	39

<b>Chapter 2. Configuration information and instructions</b> . . . . .	<b>43</b>
Updating the firmware . . . . .	43
Configuring the server . . . . .	44
Using the ServerGuide Setup and Installation CD . . . . .	45
Using the Setup Utility . . . . .	47
Using the Boot Manager . . . . .	51
Starting the backup server firmware . . . . .	51
The UpdateXpress System Pack Installer . . . . .	51
Using the integrated management module . . . . .	51
Using the remote presence and blue-screen capture features . . . . .	53
Using the embedded hypervisor . . . . .	55
Configuring the Ethernet controller . . . . .	55
Enabling Features on Demand Ethernet software . . . . .	56
Enabling Features on Demand RAID software . . . . .	56
Configuring RAID arrays . . . . .	56
Lenovo ToolsCenter Suite CLI program . . . . .	56
Using Lenovo XClarity Administrator . . . . .	57
Updating the Universal Unique Identifier (UUID) . . . . .	57
Updating the DMI/SMBIOS data . . . . .	59

<b>Chapter 3. Troubleshooting</b> . . . . .	<b>63</b>
Start here . . . . .	63
Diagnosing a problem . . . . .	63
Undocumented problems . . . . .	65
Service bulletins . . . . .	65
Checkout procedure . . . . .	66
About the checkout procedure . . . . .	66
Performing the checkout procedure . . . . .	66
Diagnostic tools . . . . .	67
Power-supply LEDs . . . . .	69
System pulse LEDs . . . . .	72
PCI riser-card LEDs . . . . .	73
Event logs . . . . .	73
POST . . . . .	75
Dynamic System Analysis . . . . .	75
Automated service request (call home) . . . . .	78
Electronic Service Agent . . . . .	78
Error messages . . . . .	78
Troubleshooting by symptom . . . . .	78
CD/DVD drive problems . . . . .	78
General problems . . . . .	79
Hard disk drive problems . . . . .	80
Hypervisor problems . . . . .	82
Intermittent problems . . . . .	83
Keyboard, mouse, or USB-device problems . . . . .	83
Memory problems . . . . .	84
Microprocessor problems . . . . .	86
Monitor and video problems . . . . .	86
Network connection problems . . . . .	88
Optional-device problems . . . . .	89
Power problems . . . . .	90
Serial-device problems . . . . .	99
ServerGuide problems . . . . .	100
Software problems . . . . .	101
USB connector problems . . . . .	101
Video problems . . . . .	102
Solving power problems . . . . .	102
Solving Ethernet controller problems . . . . .	105
Solving undetermined problems . . . . .	105
Problem determination tips . . . . .	106
Recovering the server firmware (UEFI update failure) . . . . .	107
In-band manual recovery method . . . . .	108
In-band automated boot recovery method . . . . .	109
Out-of-band method . . . . .	109
Automated boot recovery (ABR) . . . . .	109

Nx-boot failure . . . . . 110

**Chapter 4. Parts listing, Lenovo Storage DX8200 . . . . . 111**

Replaceable server components . . . . . 111  
    Structural parts and consumable parts . . . . . 127  
Power cords . . . . . 128

**Chapter 5. Installing, removing, and replacing components . . . . . 131**

Returning a device or component . . . . . 131  
Internal cable routing and connectors . . . . . 131  
    General cable routing connections . . . . . 131  
    2.5-inch hard disk drive cable connection . . . . . 132  
    3.5-inch hard disk drive cable connection . . . . . 141  
Removing and replacing structural parts . . . . . 144  
    Removing the top cover . . . . . 144  
    Replacing the top cover . . . . . 146  
Removing and replacing Tier 1 CRUs . . . . . 147  
    Removing the air baffle . . . . . 147  
    Replacing the air baffle . . . . . 148  
    Removing the power paddle module . . . . . 149  
    Replacing the power paddle module . . . . . 150  
    Removing the front USB assembly . . . . . 151  
    Replacing the front USB assembly . . . . . 152  
    Removing a hot-swap hard disk drive . . . . . 153  
    Replacing a hot-swap hard disk drive . . . . . 154  
    Removing a simple-swap hard disk drive . . . . . 156  
    Replacing a simple-swap hard disk drive . . . . . 157  
    Removing the optical drive cable . . . . . 159  
    Replacing the optical drive cable . . . . . 160  
    Removing an optical drive . . . . . 161  
    Replacing an optical drive . . . . . 162  
    Removing a memory module . . . . . 165  
    Installing a memory module . . . . . 165  
    Removing the fan cage assembly . . . . . 172  
    Replacing the fan cage assembly . . . . . 173  
    Removing a hot-swap fan . . . . . 174  
    Replacing a hot-swap fan . . . . . 175  
    Removing the media cage (also called lightpath LCD operation panel assembly) . . . . . 176  
    Replacing the media cage (also called lightpath LCD operation panel assembly) . . . . . 178  
    Removing a riser-card assembly . . . . . 180  
    Replacing a riser-card assembly . . . . . 181  
    Removing the dedicated slotless RAID controller . . . . . 183  
    Replacing the dedicated slotless RAID controller . . . . . 184  
    Removing an adapter . . . . . 185  
    Replacing an adapter . . . . . 189

Removing a RAID adapter battery/flash power module . . . . . 197  
Replacing a RAID adapter battery/flash power module . . . . . 198  
Removing the rear two hard-disk-drive kit . . . . . 200  
Replacing the rear two hard-disk-drive kit . . . . . 201  
Removing an EIA assembly . . . . . 206  
Replacing an EIA assembly . . . . . 216  
Removing a hot-swap ac power supply . . . . . 228  
Replacing a hot-swap ac power supply . . . . . 230  
Removing a hot-swap dc power supply . . . . . 233  
Replacing a hot-swap dc power supply . . . . . 236  
Removing the 2.5-inch simple-swap backplane assembly/hot-swap hard disk drive backplane . . . . . 241  
Replacing the 2.5-inch simple-swap backplane assembly/hot-swap hard disk drive backplane . . . . . 242  
Removing the 3.5-inch simple-swap backplane assembly/hot-swap hard disk drive backplane . . . . . 243  
Replacing the 3.5-inch simple-swap backplane assembly/hot-swap hard disk drive backplane . . . . . 244  
Removing a USB embedded hypervisor flash device . . . . . 246  
Replacing a USB embedded hypervisor flash device . . . . . 246  
Removing the coin-cell battery (also called CMOS battery) . . . . . 247  
Replacing the coin-cell battery (also called CMOS battery) . . . . . 250  
Removing the SD adapter . . . . . 252  
Replacing the SD adapter . . . . . 252  
Removing the LCD system information display panel . . . . . 253  
Replacing the LCD system information display panel . . . . . 256  
Removing the operator information panel assembly . . . . . 262  
Replacing the operator information panel assembly . . . . . 263  
Removing the security bezel . . . . . 264  
Replacing the security bezel . . . . . 265  
Removing and replacing Tier 2 CRUs . . . . . 265  
    Removing a microprocessor and heat sink . . . . . 265  
    Replacing a microprocessor and heat sink . . . . . 270  
    Removing the heat-sink retention module . . . . . 280  
    Replacing the heat-sink retention module . . . . . 280  
    Removing the system board . . . . . 281  
    Replacing the system board . . . . . 284  
Installing optional devices . . . . . 286  
    Installation guidelines . . . . . 287

Installing a 8x 2.5-inch simple-swap HDD ServeRAID assembly kit . . . . .	289
Installing a 8x 3.5-inch simple-swap HDD ServeRAID assembly kit . . . . .	291
Installing a 8x 2.5-inch hot-swap HDD assembly kit . . . . .	293
Installing a 8x 2.5-inch hot-swap HDD assembly with expander kit . . . . .	299
Installing a 4x 2.5-inch NVMe PCIe SSD upgrade kit . . . . .	305
Installing a PCIe thermal solution kit . . . . .	308
Installing a 2.5-inch advanced operation panel assembly kit . . . . .	309
Updating the server configuration . . . . .	310
Instructions for Business Partners . . . . .	311
How to send DSA data . . . . .	311

**Appendix A. Integrated management module II (IMM2) error messages . . .313**

IMM Events that automatically notify Support . . .	314
List of IMM events . . . . .	323

**Appendix B. UEFI/POST diagnostic codes . . . . .991**

List of UEFI events . . . . .	992
-------------------------------	-----

**Appendix C. DSA diagnostic test results . . . . . 1013**

DSA Broadcom network test results . . . . .	1013
Test results for the DSA Broadcom network test . . . . .	1013
DSA Brocade test results . . . . .	1022
Test results for the DSA Brocade test . . .	1022
DSA checkpoint panel test results . . . . .	1030
Test results for the DSA checkpoint panel test . . . . .	1030
DSA CPU stress test results . . . . .	1031
Test results for the DSA CPU stress test . .	1031
DSA Emulex adapter test results . . . . .	1034
Test results for the DSA Emulex adapter test . . . . .	1034
DSA EXA port ping test results . . . . .	1037
Test results for the DSA EXA port ping test . . . . .	1037
DSA hard drive test results . . . . .	1039
Test results for the DSA hard drive test . . .	1039
DSA Intel network test results . . . . .	1041
Test results for the DSA Intel network test . .	1041
DSA LSI hard drive test results . . . . .	1046
Test results for the DSA LSI hard drive test . . . . .	1047
DSA Mellanox adapter test results . . . . .	1048

Test results for the DSA Mellanox adapter test . . . . .	1048
DSA memory isolation test results. . . . .	1050
Test results for the DSA memory isolation test . . . . .	1050
DSA memory stress test results . . . . .	1119
Test results for the DSA memory stress test . . . . .	1119
DSA Nvidia GPU test results . . . . .	1121
Test results for the DSA Nvidia GPU test . .	1121
DSA optical drive test results . . . . .	1127
Test results for the DSA optical drive test . .	1127
DSA system management test results . . . . .	1131
Test results for the DSA system management test . . . . .	1132
DSA tape drive test results . . . . .	1143
Test results for the DSA tape drive test . . .	1143

**Appendix D. Getting help and technical assistance . . . . . 1149**

Before you call . . . . .	1149
Using the documentation . . . . .	1150
Getting help and information from the World Wide Web . . . . .	1150
How to send DSA data . . . . .	1150
Creating a personalized support web page . . .	1150
Software service and support . . . . .	1151
Hardware service and support . . . . .	1151
Taiwan product service . . . . .	1151

**Appendix E. Notices . . . . . 1153**

Trademarks . . . . .	1154
Important notes . . . . .	1154
Recycling information . . . . .	1154
Particulate contamination . . . . .	1155
Telecommunication regulatory statement . . . .	1155
Electronic emission notices . . . . .	1155
Federal Communications Commission (FCC) statement . . . . .	1156
Industry Canada Class A emission compliance statement . . . . .	1156
Avis de conformité à la réglementation d'Industrie Canada. . . . .	1156
Australia and New Zealand Class A statement . . . . .	1156
European Union EMC Directive conformance statement . . . . .	1156
Germany Class A statement . . . . .	1156
Japanese electromagnetic compatibility statements . . . . .	1157
Korea Communications Commission (KCC) statement . . . . .	1158

Russia Electromagnetic Interference (EMI) Class A statement . . . . . 1158  
People's Republic of China Class A electronic emission statement . . . . . 1158  
Taiwan Class A compliance statement . . . . . 1158

Taiwan BSMI RoHS declaration . . . . . 1159

**Index . . . . . 1161**

---

# Safety

Before installing this product, read the Safety Information.

قبل تركيب هذا المنتج، يجب قراءة الملاحظات الأمنية

Antes de instalar este produto, leia as Informações de Segurança.

在安装本产品之前，请仔细阅读 **Safety Information** (安全信息)。

安裝本產品之前，請先閱讀「安全資訊」。

Prije instalacije ovog produkta obavezno pročitajte Sigurnosne Upute.

Před instalací tohoto produktu si přečtěte příručku bezpečnostních instrukcí.

Læs sikkerhedsforskrifterne, før du installerer dette produkt.

Lees voordat u dit product installeert eerst de veiligheidsvoorschriften.

Ennen kuin asennat tämän tuotteen, lue turvaohjeet kohdasta Safety Information.

Avant d'installer ce produit, lisez les consignes de sécurité.

Vor der Installation dieses Produkts die Sicherheitshinweise lesen.

Πριν εγκαταστήσετε το προϊόν αυτό, διαβάστε τις πληροφορίες ασφάλειας (safety information).

לפני שתתקינו מוצר זה, קראו את הוראות הבטיחות.

A termék telepítése előtt olvassa el a Biztonsági előírásokat!

Prima di installare questo prodotto, leggere le Informazioni sulla Sicurezza.

製品の設置の前に、安全情報をお読みください。

본 제품을 설치하기 전에 안전 정보를 읽으십시오.

Пред да се инсталира овој продукт, прочитајте информацијата за безбедност.

பெரிய அளவில் உள்ள பின்புறப் பக்கத்தில் உள்ள பாதுகாப்புத் தகவலைப் படிக்கவும்.

Les sikkerhetsinformasjonen (Safety Information) før du installerer dette produktet.

Przed zainstalowaniem tego produktu, należy zapoznać się z książką "Informacje dotyczące bezpieczeństwa" (Safety Information).

Antes de instalar este produto, leia as Informações sobre Segurança.

Перед установкой продукта прочтите инструкции по технике безопасности.

Pred inštaláciou tohto zariadenia si pečítajte Bezpečnostné predpisy.

Pred namestitvijo tega proizvoda preberite Varnostne informacije.

Antes de instalar este producto, lea la información de seguridad.

Läs säkerhetsinformationen innan du installerar den här produkten.

ཐོན་རྐྱེན་འདི་བདེ་སྤྱོད་མ་བྱས་གོང་། རྫོང་གི་ཡིད་གཟབ་  
བྱ་འདྲ་མིན་ཡོད་པའི་འོད་སྟེར་བལྟ་དགོས།

Bu ürünü kurmadan önce güvenlik bilgilerini okuyun.

مەزكۇر مەھسۇلاتنى ئورنىتىشتىن بۇرۇن بىخەتەرلىك ئۇچۇرلىرىنى ئوقۇپ چىقىڭ.

Youq mwngz yungh canjbinj neix gaxgonq, itdingh aeu doeg aen  
canjbinj soengq cungj vahgangj ancien siusik.

---

## Safety statements

These statements provide the caution and danger information that is used in this documentation.

**Important:** Each caution and danger statement in this documentation is labeled with a number. This number is used to cross reference an English-language caution or danger statement with translated versions of the caution or danger statement in the *Safety Information* document.

For example, if a caution statement is labeled Statement 1, translations for that caution statement are in the *Safety Information* document under Statement 1.

Be sure to read all caution and danger statements in this documentation before you perform the procedures. Read any additional safety information that comes with your system or optional device before you install the device.

### Statement 1







**DANGER**

Electrical current from power, telephone, and communication cables is hazardous.

To avoid a shock hazard:

- Do not connect or disconnect any cables or perform installation, maintenance, or reconfiguration of this product during an electrical storm.
- Connect all power cords to a properly wired and grounded electrical outlet.
- Connect to properly wired outlets any equipment that will be attached to this product.
- When possible, use one hand only to connect or disconnect signal cables.
- Never turn on any equipment when there is evidence of fire, water, or structural damage.
- Disconnect the attached power cords, telecommunications systems, networks, and modems before you open the device covers, unless instructed otherwise in the installation and configuration procedures.
- Connect and disconnect cables as described in the following table when installing, moving, or opening covers on this product or attached devices.

**To Connect:**

1. Turn everything OFF.
2. First, attach all cables to devices.
3. Attach signal cables to connectors.
4. Attach power cords to outlet.
5. Turn device ON.

**To Disconnect:**

1. Turn everything OFF.
2. First, remove power cords from outlet.
3. Remove signal cables from connectors.
4. Remove all cables from devices.

### Statement 2



#### **CAUTION:**

When replacing the lithium battery, use only Part Number 33F8354 or an equivalent type battery recommended by the manufacturer. If your system has a module containing a lithium battery, replace it only with the same module type made by the same manufacturer. The battery contains lithium and can explode if not properly used, handled, or disposed of.

*Do not:*

- Throw or immerse into water
- Heat to more than 100°C (212°F)
- Repair or disassemble

Dispose of the battery as required by local ordinances or regulations.

### Statement 3



**CAUTION:**

When laser products (such as CD-ROMs, DVD drives, fiber optic devices, or transmitters) are installed, note the following:

- Do not remove the covers. Removing the covers of the laser product could result in exposure to hazardous laser radiation. There are no serviceable parts inside the device.
- Use of controls or adjustments or performance of procedures other than those specified herein might result in hazardous radiation exposure.



Some laser products contain an embedded Class 3A or Class 3B laser diode. Note the following. Laser radiation when open. Do not stare into the beam, do not view directly with optical instruments, and avoid direct exposure to the beam.

Class 1 Laser Product

Laser Klasse 1

Laser Klass 1

Luokan 1 Laserlaite

Appareil À Laser de Classe 1

**Statement 4**



**CAUTION:** Use safe practices when lifting.

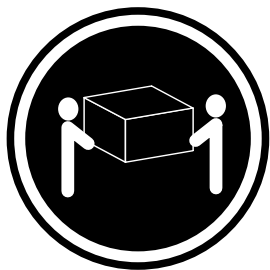

≥ 18 kg (39.7 lb)

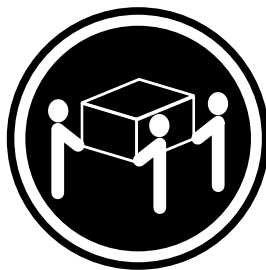

≥ 32 kg (70.5 lb)

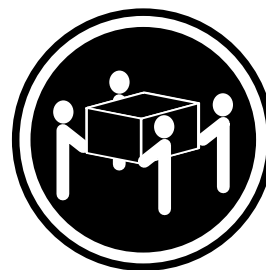

≥ 55 kg (121.2 lb)

**Statement 5**



**CAUTION:**

The power control button on the device and the power switch on the power supply do not turn off the electrical current supplied to the device. The device also might have more than one power cord. To remove all electrical current from the device, ensure that all power cords are disconnected from the power source.

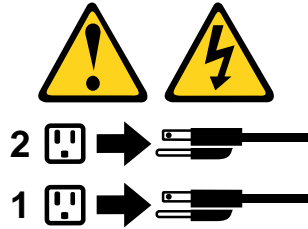

**Statement 6**



**CAUTION:**

If you install a strain-relief bracket option over the end of the power cord that is connected to the device, you must connect the other end of the power cord to an easily accessible power source.

**Statement 8**



**CAUTION:**

Never remove the cover on a power supply or any part that has the following label attached.



Hazardous voltage, current, and energy levels are present inside any component that has this label attached. There are no serviceable parts inside these components. If you suspect a problem with one of these parts, contact a service technician.

**Statement 12**



**CAUTION:**

The following label indicates a hot surface nearby.



**Statement 26**



**CAUTION:**  
Do not place any object on top of rack-mounted devices.

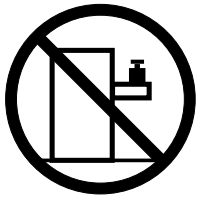

**Statement 27**



**CAUTION:**  
Hazardous moving parts are nearby.



**Rack Safety Information, Statement 2**



 **DANGER**

- Always lower the leveling pads on the rack cabinet.
- Always install stabilizer brackets on the rack cabinet.
- Always install servers and optional devices starting from the bottom of the rack cabinet.
- Always install the heaviest devices in the bottom of the rack cabinet.

---

# Chapter 1. The Lenovo Storage DX8200 server

This *Installation and Service Guide* contains information and instructions for setting up your Lenovo Storage DX8200 server, instructions for installing some optional devices, cabling and configuring the server, removing and replacing devices, and diagnostics and troubleshooting information.

In addition to the instructions in “Installing optional devices” on page 286 for installing optional hardware devices, updating firmware and device drivers, and completing the installation, Business Partners must also complete the steps in “Instructions for Business Partners” on page 311.

Lenovo Storage DX8200 is a software-defined storage product which is designed based on Lenovo System x3650 M5 servers. This document shows all the components supported by System x3650 M5 servers. For a list of components supported by different models of Lenovo Storage DX8200, go to the Lenovo support Web site.

The Lenovo Storage DX8200 server is a 2-U-high<sup>1</sup> rack model server for high-volume network transaction processing. This high-performance, multi-core server is ideally suited for networking environments that require superior microprocessor performance, input/output (I/O) flexibility, and high manageability.

Performance, ease of use, reliability, and expansion capabilities were key considerations in the design of the server. These design features make it possible for you to customize the system hardware to meet your needs today and provide flexible expansion capabilities for the future.

The server comes with a limited warranty. For information about the terms of the warranty, see the *Warranty Information* document that comes with the server.

The server contains Lenovo X-Architecture technologies, which help increase performance and reliability. For more information, see “What your server offers” on page 13 and “Reliability, availability, and serviceability” on page 16.

You can obtain up-to-date information about the server and other server products at <http://shop.lenovo.com/us/en/systems/>. At <http://www.ibm.com/support/mysupport/>, you can create a personalized support page by identifying products that are of interest to you. From this personalized page, you can subscribe to weekly e-mail notifications about new technical documents, search for information and downloads, and access various administrative services.

If you participate in the client reference program, you can share information about your use of technology, best practices, and innovative solutions; build a professional network; and gain visibility for your business. For more information about the client reference program, see <http://www.ibm.com/ibm/clientreference/>.

## Notes:

- The illustrations in this document might differ slightly from your model.
- The following components are available only on some models:
  - Video connector
  - LCD system information display panel
  - Optical drive

---

1. Racks are marked in vertical increments of 1.75 inches each. Each increment is referred to as a unit, or a “U”. A 1-U-high device is approximately 1.75 inches tall.

In terms of simple-swap configurations, the server comes with either eight 2.5-inch or eight 3.5-inch simple-swap hard disk drive bays. The 2.5-inch simple-swap models are capable of expansion to sixteen 2.5-inch simple-swap hard disk drive bays with two simple-swap serverRAID option kits.

In terms of hot-swap configurations, the server comes with either eight 3.5-inch SAS/SATA or eight 2.5-inch SAS/SATA hot-swap hard disk drive bays. Most models contain a ServerRAID SAS controller. The 2.5-inch models are capable of expansion to twenty-four 2.5-inch SAS/SATA hot-swap hard disk drive bays while the 3.5-inch models are capable of expansion to twelve 3.5-inch SAS/SATA hot-swap hard disk drive bays.

**Note:** The ID for each bay is printed on the server front, above each bay.

The following illustration shows a server with eight 2.5-inch simple-swap hard disk drive bays. You can purchase an optional kit to install the eight additional 2.5-inch simple-swap hard disk drives to upgrade the server to sixteen 2.5-inch simple-swap hard disk drive bays.

**Note:** The basic 2.5-inch simple-swap model supports SATA simple-swap hard disk drives only. With the simple-swap serverRAID function, it supports SATA and SAS simple-swap hard disk drives.

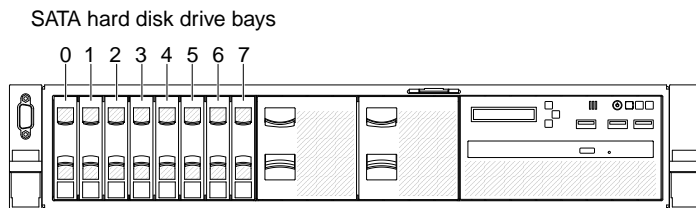

Figure 1. 2.5-inch simple-swap model front view

The following illustration shows a server with eight 2.5-inch hot-swap hard disk drive bays.

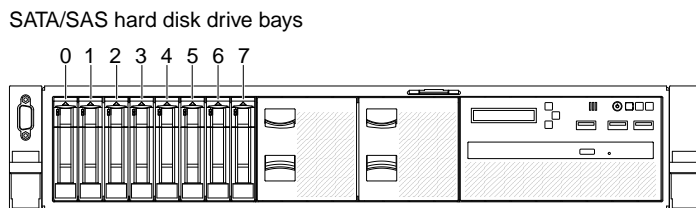

Figure 2. 2.5-inch hot-swap model front view

You can purchase an optional kit to install the eight additional 2.5-inch hard disk drive bays. The following illustration shows a server with sixteen 2.5-inch hot-swap hard disk drive bays.

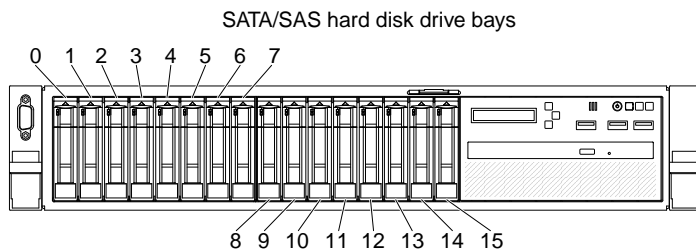

Figure 3. 16-drive-capable model front view

You can purchase an optional kit to install the eight additional 2.5-inch hard disk drive bays to a 24-drive-capable model. The following illustration shows a server with twenty-four 2.5-inch hot-swap hard disk drive bays.

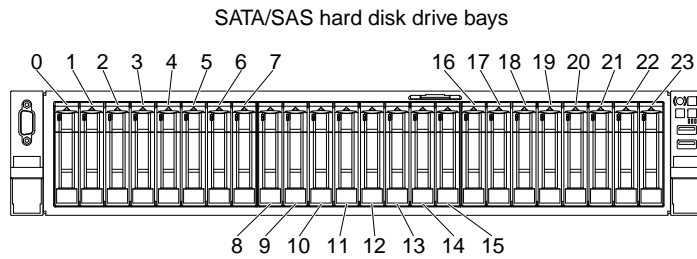

Figure 4. 24-drive-capable model front view

The following illustration shows a server with eight 3.5-inch simple-swap hard disk drive bays. Moreover, you can purchase an option to obtain the simple-swap serverRAID function.

**Note:** The basic 3.5-inch simple-swap model supports SATA simple-swap hard disk drives only. With the simple-swap serverRAID function, it supports SATA and SAS simple-swap hard disk drives.

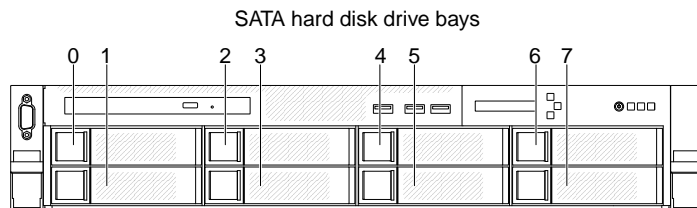

Figure 5. 3.5-inch simple-swap model front view

The following illustration shows a server with eight 3.5-inch hot-swap hard disk drive bays.

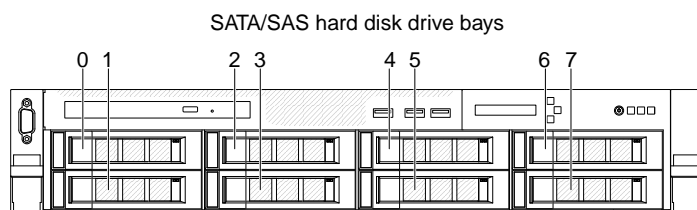

Figure 6. 3.5-inch hot-swap model front view

The following illustration shows a server with twelve 3.5-inch hot-swap hard disk drive bays.

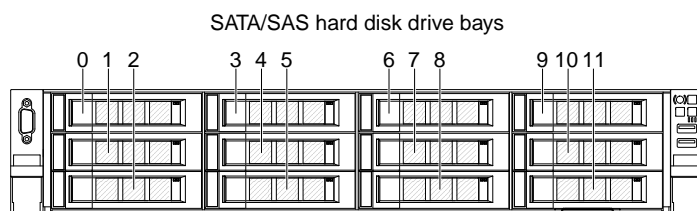

Figure 7. 12-drive-capable model front view

If firmware and documentation updates are available, you can download them from the website. The server might have features that are not described in the documentation that comes with the server, and the

documentation might be updated occasionally to include information about those features, or technical updates might be available to provide additional information that is not included in the server documentation. To check for updates, go to <http://www.lenovo.com/support>.

Record information about the server in the following table.

Table 1. Record of the system information

Product name	Machine Type (s)	Model number	Serial number
Lenovo Storage DX8200	5120, 5128, 5133, 5135, 5136, and 5139		

The model number and serial number are on the ID label on the front of the server, as shown in the following illustration.

**Note:** The illustrations in this document might differ slightly from your hardware.

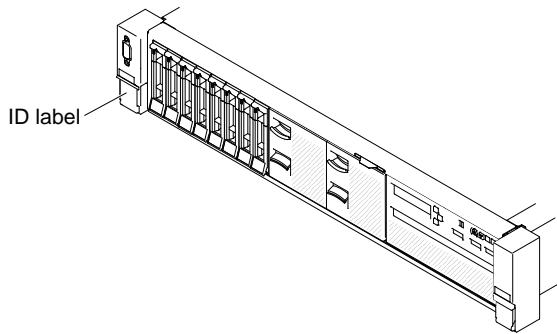

Figure 8. ID label

You can download a *ServerGuide Setup and Installation* CD to help you configure the hardware, install device drivers, and install the operating system.

For a list of supported optional devices for the server, see <http://www.lenovo.com/serverproven/>.

See the *Rack Installation Instructions* document on the *System x Documentation* CD for complete rack installation and removal instructions.

---

## The Documentation CD

The *Documentation* CD contains documentation for the server in Portable Document Format (PDF) and includes the Documentation Browser to help you find information quickly.

## Hardware and software requirements

The hardware and software requirements of the *Documentation* CD.

The *Documentation* CD requires the following minimum hardware and software:

- Microsoft Windows XP, Windows 2000, or Red Hat Linux
- 100 MHz microprocessor
- 32 MB of RAM
- Adobe Acrobat Reader 3.0 (or later) or xpdf, which comes with Linux operating systems



## The Documentation CD

Use the Documentation Browser to browse the contents of the CD, read brief descriptions of the documents, and view documents, using Adobe Acrobat Reader or xpdf.

The Documentation Browser automatically detects the regional settings in use in your server and displays the documents in the language for that region (if available). If a document is not available in the language for that region, the English-language version is displayed.

Use one of the following procedures to start the Documentation Browser:

- If Autostart is enabled, insert the CD into the CD or DVD drive. The Documentation Browser starts automatically.
- If Autostart is disabled or is not enabled for all users, use one of the following procedures:
  - If you are using a Windows operating system, insert the CD into the CD or DVD drive and click **Start -> Run**. In the **Open** field, type  
`e:\win32.bat`  
where *e* is the drive letter of the CD or DVD drive, and click **OK**.
  - If you are using Red Hat Linux, insert the CD into the CD or DVD drive; then, run the following command from the `/mnt/cdrom` directory:  
`sh runlinux.sh`

Select the server from the **Product** menu. The **Available Topics** list displays all the documents for the server. Some documents might be in folders. A plus sign (+) indicates each folder or document that has additional documents under it. Click the plus sign to display the additional documents.

When you select a document, a description of the document is displayed under **Topic Description**. To select more than one document, press and hold the Ctrl key while you select the documents. Click **View** to view the selected document or documents in Acrobat Reader or xpdf. If you selected more than one document, all the selected documents are opened in Acrobat Reader or xpdf.

To search all the documents, type a word or word string in the **Search** field and click **Search**. The documents in which the word or word string appears are listed in order of the most occurrences. Click a document to view it, and press Ctrl+F to use the Acrobat search function, or press Alt+F to use the xpdf search function within the document.

Click **Help** for detailed information about using the Documentation Browser.

---

## Related documentation

This *Installation and Service Guide* contains general information about the server including how to set up and cable the server, how to install supported optional devices, how to configure the server, and information to help you solve problems yourself and information for service technicians.

The following documentation also comes with the server:

- *Environmental Notices and User Guide*  
This document is in PDF format on the *Documentation* CD. It contains translated environmental notices.
- *License Agreement for Machine Code*  
This document is in PDF format on the *Documentation* CD. It provides translated versions of the *License Agreement for Machine Code* for your product.
- *Important Notices*  
This document is in printed format and comes with the server. It contains information about the safety, environmental, and electronic emission notices for your product.

- *Licenses and Attributions Documents*

This document is in PDF format on the *Documentation* CD. It provides the open source notices.

- *Rack Installation Instructions*

This printed document contains instructions for installing the server in a rack and comes with the rack kit.

- *Safety Information*

This document is in PDF format on the *Documentation* CD. It contains translated caution and danger statements. Each caution and danger statement that appears in the documentation has a number that you can use to locate the corresponding statement in your language in the *Safety Information* document.

- *Safety Information Labels*

This document provides the Simplified Chinese, Mongolian, Tibetan, Uygur, and Zhuang translated versions of the product safety labels.

- *Warranty Information*

This document is in printed format and comes with the server. It contains warranty terms and a pointer to the Statement of Limited Warranty on the website.

Depending on the server model, additional documentation might be included on the *Documentation* CD.

The ToolsCenter for System x and BladeCenter is an online information center that contains information about tools for updating, managing, and deploying firmware, device drivers, and operating systems. The ToolsCenter for System x and BladeCenter is at <http://publib.boulder.ibm.com/infocenter/toolsctr/v1r0/>.

The server might have features that are not described in the documentation that you received with the server. The documentation might be updated occasionally to include information about those features, or technical updates might be available to provide additional information that is not included in the server documentation. These updates are available from the website. To check for updates, go to <http://www.lenovo.com/support>.

---

## Notices and statements in this document

The caution and danger statements in this document are also in the multilingual *Safety Information* document, which is on the *System x Documentation* CD. Each statement is numbered for reference to the corresponding statement in your language in the *Safety Information* document.

The following notices and statements are used in this document:

- **Note:** These notices provide important tips, guidance, or advice.
- **Important:** These notices provide information or advice that might help you avoid inconvenient or problem situations.
- **Attention:** These notices indicate potential damage to programs, devices, or data. An attention notice is placed just before the instruction or situation in which damage might occur.
- **Caution:** These statements indicate situations that can be potentially hazardous to you. A caution statement is placed just before the description of a potentially hazardous procedure step or situation.
- **Danger:** These statements indicate situations that can be potentially lethal or extremely hazardous to you. A danger statement is placed just before the description of a potentially lethal or extremely hazardous procedure step or situation.

---

## Server features and specifications

The following information is a summary of the features and specifications of the server. Depending on the model, some features might not be available, or some specifications might not apply.

**Microprocessor (depending on the model):**

- Supports up to two Intel Xeon™ E5-2600 v4 series multi-core microprocessors (one installed)
- Two QuickPath Interconnect (QPI) links speed up to 9.6 GT per second

**Notes:**

- Use the Setup Utility program to determine the type and speed of the microprocessors.
- For a list of supported microprocessors, see <http://www.lenovo.com/serverproven/>.

**Memory (depending on the model):**

- Minimum: 8 GB
- Maximum: 1.5 TB
  - 768 GB using registered DIMMs (RDIMMs)
  - 1.5 TB using load reduction DIMMs (LRDIMMs)
- Type:
  - PC4-19200 (DDR4-2400), operating speed depends on memory population
  - Single-rank, dual-rank, or quad-rank
  - Registered DIMM (RDIMM) or load reduced DIMM (LRDIMM)
- Slots: 24 dual inline
- Supports (depending on the model):
  - 8 GB, 16 GB, and 32 GB RDIMMs
  - 64 GB LRDIMMs

**Integrated functions:**

- Integrated management module 2.1 (IMM2.1), which consolidates multiple management functions in a single chip.
- Broadcom BCM5719 Quad Port Gigabit Ethernet controller with Wake on LAN support
- Up to six Universal Serial Bus (USB) connectors (depending on the model)
  - Three USB 2.0 connectors on the front of the chassis
  - Two USB 3.0 connectors on the rear of the chassis
  - One internal USB 2.0 connector used for Hypervisor USB key
- Four network ports (four 1 Gb Ethernet ports on the system)
- Supports one optional ML2 network daughter card
- One System Management RJ-45 on the rear to connect to a systems management network. This system management connector is dedicated to the IMM2.1 functions.
- Optional serial port

**Hard disk drive expansion bays (depending on the model):**

- 2.5-inch models:
  - Supports up to sixteen 2.5-inch simple-swap SAS/SATA hard disk drive bays.
  - Supports up to twenty-six 2.5-inch hot-swap SAS/SATA hard disk drive bays .
- 3.5-inch models:
  - Supports up to eight 3.5-inch simple-swap SAS/SATA hard disk drive bays.
  - Supports up to fourteen 3.5-inch hot-swap and two 2.5-inch hot-swap SAS/SATA hard disk drive bays.

**Attention:** As a general consideration, do not mix standard 512-byte and advanced 4-KB format drives in the same RAID array because it may lead to potential performance issues.

**SATA optical drives (optional):**

- DVD-ROM
- Multi-burner

**RAID controllers (depending on the model):**

- A ServeRAID M1215 SAS/SATA adapter that provides RAID 0, 1, and 10 with optional FoD RAID 5/50 and SED (Self Encrypting Drive) upgrade.
- A ServeRAID M5210 SAS/SATA adapter that provides RAID 0, 1, and 10. Optional upgrade:
  - RAID 5/50 (1 GB Cache) with optional FoD RAID 6/60 and SED upgrade
  - RAID 5/50 (1 GB Flash) with optional FoD RAID 6/60 and SED upgrade
  - RAID 5/50 (2 GB Flash) with optional FoD RAID 6/60 and SED upgrade
  - RAID 5/50 (4 GB Flash) with optional FoD RAID 6/60 and SED upgrade
  - FoD RAID 6/60 Upgrade
  - FoD Zero Cache/RAID 5/50
  - FoD Performance Accelerator
  - FoD SSD Caching Enabler

**Video controller (integrated into IMM2.1):**

- Matrox G200eR2

**Note:** The maximum video resolution is 1600 x 1200 at 75 Hz.

- SVGA compatible video controller
- DDR3 528 MHz SDRAM video memory controller
- Avocent Digital Video Compression
- 16 MB of video memory (not expandable)

**Size (2U):**

- Height: 86.5 mm (3.406 inch)
- Depth: EIA flange to rear - 755 mm (29.724 inch), Overall - 800 mm (31.496 inch)
- Width: With top cover - 445.6 mm (17.543 inch), With EIA - 482.0 mm (18.976 inch)
- Weight: approximately 28 kg (62 lb) to 34 kg (75 lb) depending upon configuration

**PCI expansion slots:**

**Riser-card assembly 1**

- Type 1
  - Slot 1: PCI Express 3.0 x8 (full-height, full-length)
  - Slot 2: PCI Express 3.0 x8 (full-height, full-length)
  - Slot 3: PCI Express 3.0 x8 (full-height, half-length)
- Type 2
  - Slot 1: PCI Express 3.0 x8 (full-height, full-length)
  - Slot 2: PCI Express 3.0 x8 (full-height, full-length)
  - Slot 3: ML2
- Type 3
  - Slot 1: PCI Express 3.0 x16 (full-height, full-length)
  - Slot 2: Not available
  - Slot 3: PCI Express 3.0 x8 (full-height, half-length)
- Type 4
  - Slot 1: PCI Express 3.0 x16 (full-height, full-length)
  - Slot 2: Not available
  - Slot 3: ML2

**PCI expansion slots 4**

- Slot 4: PCI Express 3.0 x8 (low-profile)

**PCI expansion slots 5**

- Slot 5: PCI Express 3.0 x16 (low-profile)

## Riser-card assembly 2

- Type 5
  - Slot 6: PCI Express 3.0 x8 (full-height, full-length)
  - Slot 7: PCI Express 3.0 x8 (full-height, full-length)
  - Slot 8: PCI Express 3.0 x8 (full-height, half-length)
- Type 6
  - Slot 6: PCI Express 3.0 x16 (full-height, full-length)
  - Slot 7: Not available
  - Slot 8: PCI Express 3.0 x8 (full-height, half-length)

## Electrical input:

Sine-wave AC input (50/60 Hz) required

- For 550W/750W/900W AC Platinum power supplies:
  - Input voltage low range:
    - Minimum: 100 Vac
    - Maximum: 127 Vac
  - Input voltage high range:
    - Minimum: 200 Vac
    - Maximum: 240 Vac
- For 750W/1300W Titanium and 1500W Platinum power supplies:
  - Input voltage range:
    - Minimum: 200 Vac
    - Maximum: 240 Vac

DC input required

- For 900W DC power supply
  - Input voltage range:
    - Minimum: -48 Vdc
    - Maximum: -60 Vdc

Maximum Input kilovolt-amperes (kVA), approximately:

- The Minimum Configuration: 0.093 kVA
- The Maximum Configuration: 1.967 kVA

## Notes:

1. Power consumption and heat output vary depending on the number and type of optional features installed and the power-management optional features in use.
2. The noise emission level stated is the declared (upper limit) sound power level, in bels, for a random sample of machines. All measurements are made in accordance with ISO 7779 and reported in conformance with ISO 9296. Actual sound-pressure levels in a given location might exceed the average values stated because of room reflections and other nearby noise sources. The noise emission level stated in the declared (upper limit) sound-power level, in bels, for a random sample of system.

## Hot-swap fans:

- One microprocessor: four single-motor hot-swap fans
- Two microprocessors: six single-motor hot-swap fans

**Note:** Your server supports single-motor fans only. On the integrated management module (IMM) Web interface or the ipmitool program interface, the value of **Fan xB Tach** is not available. **x** represents the fan ID.

**Power supply:**

- Up to two hot-swap power supplies for redundancy support
  - 550-watt ac 80 PLUS Platinum
  - 750-watt ac 80 PLUS Platinum
  - 750-watt ac 80 PLUS Titanium
  - 900-watt ac 80 PLUS Platinum
  - 900-watt dc
  - 1300-watt ac 80 PLUS Titanium
  - 1500-watt ac 80 PLUS Platinum

**Notes:**

1. Power supplies and redundant power supplies in the server must be with the same power rating, wattage or level.
2. You may use the Power Configurator utility to determine current system power consumption. For more information and to download the utility, go to <http://www.ibm.com/systems/bladecenter/resources/powerconfig.html>.

**Acoustical noise emissions:**

- Sound power, idling: 6.4 bels maximum
- Sound power, operating: 6.6 bels maximum

**Notes:**

1. The noise emission level stated is the declared (upper limit) sound power level, in bels, for a random sample of machines. All measurements are made in accordance with ISO 7779 and reported in conformance with ISO 9296.
2. The PCIe options supported in this system vary greatly in function, power draw, and required cooling. Any increase in cooling required by these options will result in increased fan speed and produced sound power level. The actual sound pressure levels measured in your installation depend upon a variety of factors, including the number of racks in the installation; the size, materials, and configuration of the room; the noise levels from other equipment; the room ambient temperature and pressure, and employees' location in relation to the equipment.

**Heat output:**

Approximate heat output:

- Minimum configuration: 525.45 Btu per hour (AC 154 watts)
- Maximum configuration: 6667 Btu per hour (AC 1954 watts)

**Environment:**

The Lenovo Storage DX8200 compute node complies with ASHRAE class A3 specifications.

**Power on:**

- Temperature: 5°C–40°C (41°F–104°F) up to 950 m (3117 ft). Above 950 m (3117 ft), de-rated maximum air temperature is 1°C (33.8°F) per 175 m (574 ft).
- Humidity, non-condensing: -12°C dew point (10.4°F) and 8%–85% relative humidity.
- Maximum dew point: 24°C (75°F)
- Maximum altitude: 3050 m (10000 ft) and 5°C–28°C (41°F–82°F)
- Maximum rate of temperature change: 5°C/hr (41°F/hr) for tape drive, 20°C/hr (68°F/hr) for HDDs

**Power off:**

- Temperature: 5°C–45°C (41°F–113°F)
- Relative humidity: 8%–85%
- Maximum dew point: 27°C (80.6°F)

**Storage (non-operating):**

- Temperature: 1°C–60°C (33.8°F–140°F)
- Altitude: 3050 m (10000 ft)
- Relative humidity: 5%–80%
- Maximum dew point: 29°C (84.2°F)

**Shipment (non-operating):**

- Temperature: -40°C–60°C (-40°F–140°F)
- Altitude: 10,700 m (35105 ft)
- Relative humidity: 5%–100%
- Maximum dew point: 29°C (84.2°F)

**Attention:**

- Design to ASHRAE Class A3, ambient of 40°C (104°F), with relaxed support:
  - Support cloud like workload with no performance degradation acceptable (Turbo-Off).
  - Under no circumstance, can any combination of worst case workload and configuration result in system shutdown or design exposure at 40°C (104°F).
- Chassis is powered on.
- A3 - Derate maximum allowable temperature 1°C (33.8°F) per 175 m (574 ft) above 950 m (3117 ft).
- The minimum humidity level for class A3 is the higher (more moisture) of the -12°C (10.4°F) dew point and the 8% relative humidity. These intersect at approximately 25°C (77°F). Below this intersection (~25°C) the dew point (-12°C) represents the minimum moisture level, while above it relative humidity (8%) is the minimum.
- Moisture levels lower than 0.5°C (32.9°F) dew point, but not lower -10°C (14°F) dew point or 8% relative humidity, can be accepted if appropriate control measures are implemented to limit the generation of static electricity on personnel and equipment in the data center. All personnel and mobile furnishings and equipment must be connected to ground via an appropriate static control system. The following items are considered the minimum requirements:
  - Conductive materials (conductive flooring, conductive footwear on all personnel that go into the datacenter, all mobile furnishings and equipment will be made of conductive or static dissipative materials).
  - During maintenance on any hardware, a properly functioning wrist strap must be used by any personnel who contacts IT equipment.
- 5°C/hr (41°F/hr) for data centers employing tape drives and 20°C/hr (68°F/hr) for data centers employing disk drives.
- Chassis is removed from original shipping container and is installed but not in use, for example, during repair, maintenance, or upgrade.
- The equipment acclimation period is 1 hour per 20°C (68°F/hr) of temperature change from the shipping environment to the operating environment.
- Condensation is acceptable, but not rain.

- When the ambient temperature is higher than 36°C (96.8°F), 135-watt and 145-watt microprocessors might face performance degradation when operating a heavy workload.
- Your server supports the active Graphics Processing Unit (GPU) only. To support the GPU, observe the following system requirements:

Chassis	GPU wattage	Ambient temperature	CPU wattage
3.5-inch-drive chassis	Not exceed 240 watt	Not exceed 35°C (95°F)	No special requirement
3.5-inch-drive chassis	Above 240 watt	Not exceed 30°C (86°F)	For 300-watt Intel Phi GPU (supported in 3.5-inch-drive chassis only), the CPU wattage must not exceed 120 watt.
2.5-inch-drive chassis	Not exceed 300 watt	Not exceed 35°C (95°F)	No special requirement

When the ambient temperature is above 35°C (95°F), the GPU is not supported due to thermal limitation.

- To support IO accelerator adapters, the ambient temperature must meet the following requirements:
  - For 3.5-inch-drive chassis, ensure that the ambient temperature does not exceed 30°C (86°F).
  - For 2.5-inch-drive chassis, ensure that the ambient temperature does not exceed 35°C (95°F).
- If an ML2 card is installed, you must install a PCIe thermal kit for proper cooling. See “Installing a PCIe thermal solution kit” on page 308.

Particulate contamination: airborne particulates and reactive gases acting alone or in combination with other environmental factors such as humidity or temperature might pose a risk to the server. For information about the limits for particulates and gases, see “Particulate contamination” on page 1155.

## Rail and supported rack specifications

<b>Option name</b>	System x Enterprise Slides Kit	System x Gen II Universal Slides Kit	System x M5 Custom Rail Kit	Lenovo Server 2U/1U 4-Post Friction Rail kit  (support from November 2016)
<b>Option part number</b>	00FK656	00KA500	00MW239	00MV369
<b>Rail type</b>	Full-out slide rail (ball bearing), toolless installation	Full-out slide rail (ball bearing)	Half-out slide rail (friction), toolless installation	Half-out slide rail (friction), toolless installation
<b>Supported rack type</b>	Four-post IBM and Lenovo standard rack, complying with the International Electrotechnical Commission (IEC) standard  If a 0U power distribution unit (PDU) is to be installed, read the notes at the bottom.	Any four-post rack, complying with the IEC standard  If a 0U PDU is to be installed, read the notes at the bottom.	Four-post IBM and Lenovo standard rack, complying with the IEC standard  If a 0U PDU is to be installed, read the notes at the bottom.	Four-post IBM and Lenovo standard rack, complying with the IEC standard  If a 0U PDU is to be installed, read the notes at the bottom.



<b>Service on rack</b>	Yes	Yes	No	No
<b>Cable management arm (CMA) support</b>	Yes	Yes	No	No
<b>1U PDU support</b>	Yes	Yes	Yes	Yes
<b>0U PDU support</b>	Limited support. Read the notes at the bottom.	Limited support. Read the notes at the bottom.	Limited support. Read the notes at the bottom.	Limited support. Read the notes at the bottom.
<b>Mounting holes</b>	Square or round	Square, round, or threaded	Square or round	Square or round
<b>Thickness of mounting flanges</b>	2 mm (0.08 inch) – 3.3 mm (0.13 inch)	2 mm (0.08 inch) – 4.65 mm (0.18 inch)	2 mm (0.08 inch) – 4 mm (0.16 inch)	2 mm (0.08 inches) – 4 mm (0.16 inches)
<b>Distance between front and rear mounting flanges</b>	617 mm (24.29 inches) – 812 mm (31.97 inches)	617 mm (24.29 inches) – 812 mm (31.97 inches)	595 mm (23.43 inches) – 746 mm (29.37 inches)	609.6 mm (24 inches) – 914.4 mm (36 inches)
<b>Rail length (measured when mounted on the rack, starting from the front surface of the front mounting flange to the rear most point of the rail)</b>	833.5 mm (32.81 inches)	836.8 mm (32.94 inches)	755 mm (29.72 inches)	728.1 mm (28.6 inches)

**Notes:**

- If you want to install the rails and a 0U PDU into the same rack, the rack must meet the following height and depth requirements:
  - 42U or higher
  - For 00MW239 and 00MV369 rails: at least 1000-mm (39.37-inch) deep
  - For 00FK656 and 00KA500 rails: at least 1100-mm (43.31-inch) deep if no CMA is to be installed; at least 1200-mm (47.24-inch) deep if a CMA is to be installed
- The option part numbers might change.

---

## What your server offers

This section introduces features and technologies the server uses and provides.

- **Dynamic System Analysis (DSA)**

The server comes with the Dynamic System Analysis (DSA) Preboot diagnostic program stored in the integrated USB memory on the server. DSA collects and analyzes system information to aid in diagnosing server problems, as well as offering a rich set of diagnostic tests of the major components of the server. DSA creates a DSA log, which is a chronologically ordered merge of the system-event log (as the IPMI event log), the integrated management module II (IMM2) event log (as the ASM event log), and the operating-system event logs. You can send the DSA log as a file to Lenovo Support or view the information as a text file or HTML file.

For more information about DSA Preboot, see “DSA Preboot” on page 76.

- **Features on Demand**

If a Features on Demand feature is integrated in the server or in an optional device that is installed in the server, you can purchase an activation key to activate the feature. For information about Features on Demand, see <http://www.ibm.com/systems/x/fod/>.

- **ServerGuide Setup and Installation CD**

The *ServerGuide Setup and Installation* CD, which you can download from the web, provides programs to help you set up the server and install a Windows operating system. The ServerGuide program detects installed optional hardware devices and provides the correct configuration programs and device drivers. For more information about the *ServerGuide Setup and Installation* CD, see “Using the ServerGuide Setup and Installation CD” on page 45.

- **Lenovo XClarity Administrator**

Lenovo XClarity Administrator is a centralized, resource-management solution that simplifies infrastructure management, speeds responses, and enhances the availability of Lenovo server systems and solutions. It runs as a virtual appliance that automates discovery, inventory, tracking, monitoring, and provisioning for Lenovo servers in a secure environment. For more information, see “Using Lenovo XClarity Administrator ” on page 57.

- **Lenovo XClarity Energy Manager**

Lenovo XClarity Energy Manager is a tool for data center power management. It models the data center physical hierarchy and monitors power and temperature at the server level and the group level. By analyzing power and temperature data, Lenovo XClarity Energy Manager helps you improve business continuity and increase power efficiency. For more information, go to <http://support.lenovo.com/us/en/downloads/ds101160>.

- **Lenovo ToolsCenter Suite CLI**

Lenovo ToolsCenter Suite CLI is a collection of server management tools that utilize a command-line interface program to manage firmware, hardware, and operating systems for CMM, IMM, and Flex-IOM based systems using the applications. Lenovo ToolsCenter Suite CLI is comprised of individual ToolsCenter application modules that are easily updated. For more information, go to <https://support.lenovo.com/us/en/documents/LNVO-CENTER>.

- **Integrated management module 2.1 (IMM2.1)**

The IMM2.1 combines service processor functions, video controller, and remote presence and blue-screen capture features in a single chip. The IMM provides advanced service-processor control, monitoring, and alerting function. If an environmental condition exceeds a threshold or if a system component fails, the IMM lights LEDs to help you diagnose the problem, records the error in the IMM event log, and alerts you to the problem. Optionally, the IMM also provides a virtual presence capability for remote server management capabilities. The IMM provides remote server management through the following industry-standard interfaces:

- Intelligent Platform Management Interface (IPMI) version 2.0
- Simple Network Management Protocol (SNMP) version 3.0; SNMP Trap version 1.0
- Common Information Model (CIM)
- Web browser

Some of the features that are unique to the IMM are enhanced performance, higher-resolution remote video, expanded security options, and Feature on Demand enablement for hardware and firmware options.

For additional information, see “Using the integrated management module” on page 51 and the Integrated Management Module II User’s Guide at [http://publib.boulder.ibm.com/infocenter/systemx/documentation/topic/com.lenovo.sysx.imm2.doc/printable\\_doc.html](http://publib.boulder.ibm.com/infocenter/systemx/documentation/topic/com.lenovo.sysx.imm2.doc/printable_doc.html).

- **Integrated network support**

The server comes with an integrated dual-port Intel Gigabit Ethernet controller, which supports connection to a 10 Mbps, 100 Mbps, or 1000 Mbps network. For more information, see “Configuring the Ethernet controller” on page 55.

- **Integrated Trusted Platform Module (TPM)**

This integrated security chip performs cryptographic functions and stores private and public secure keys. It provides the hardware support for the Trusted Computing Group (TCG) specification. You can download the software to support the TCG specification, when the software is available. You can enable TPM support through the Setup Utility under the **System Security** menu option.

- **Large data-storage capacity and hot-swap capability**

The hot-swap server models support a maximum of twenty-six 2.5-inch or fourteen 3.5-inch hot-swap Serial Attached SCSI (SAS) hard disk drives or hot-swap Serial ATA (SATA) hard disk drives. The simple-swap server models support a maximum of sixteen 2.5-inch or eight 3.5-inch simple-swap SATA hard disk drives.

With the hot-swap feature, you can add, remove, or replace hard disk drives without turning off the server.

- **Large system-memory capacity**

The server can support up to 1.5 TB of system memory. The server provides 24 dual inline memory module (DIMM) connectors. The server memory controller supports error correcting code (ECC) for PC4-17000 (DDR4-2400), DDR4 (fourth-generation double-data-rate), synchronous dynamic random access memory (SDRAM) DIMMs.

- **Mobile access to Service Information website**

The server provides a QR code on the system service label, which is on the cover of the server, that you can scan using a QR code reader and scanner with a mobile device to get quick access to the Service Information website. The Service Information website provides additional information for parts installation and replacement videos, and error codes for server support. For the QR code, see QR code information on page Chapter 1 “The Lenovo Storage DX8200 server” on page 1.

- **Multi-core processing**

The server supports up to two Intel Xeon™ E5-2600 v4 series multi-core microprocessors. The server comes with a minimum of one microprocessor.

- **PCI adapter capabilities**

The server has two PCI interface risers. See “Replacing an adapter” on page 189 for detailed information.

- **SD adapter**

A raid controller for Secure Digital (SD) media. It has two upstream connections, a USB connection to the server chipset, and an MMC connection to the IMM2.1.

- **Redundant connection**

The addition of the optional Ethernet adapter provides failover capability to a redundant Ethernet connection with the applicable application installed. If a problem occurs with the primary Ethernet connection and the optional Ethernet adapter is installed on the server, all Ethernet traffic that is associated with the primary connection is automatically switched to the optional redundant Ethernet adapter connection. If the applicable device drivers are installed, this switching occurs without data loss and without user intervention.

- **Redundant cooling and optional power capabilities**

The server supports a maximum of two 550-watt, 750-watt, 900-watt, 1300-watt or 1500-watt hot-swap power supplies and six single-motor hot-swap fans, which provide redundancy and hot-swap capability for a typical configuration. The redundant cooling by the fans in the server enables continued operation if one of the fans fails. The server comes with the minimum of one 550-watt, 750-watt, 900-watt, 1300-watt or 1500-watt hot-swap power supply and four fans.

You must install the fifth and sixth fans when you install the second microprocessor in the server. You can order the second optional power supply for power redundancy.

**Note:** You cannot mix different wattages and different 80 plus efficiency level of power supplies in the server.

- **ServeRAID support**

The ServeRAID adapter provides hardware redundant array of independent disks (RAID) support to create configurations. The standard RAID adapter provides RAID levels 0, 1, and 10. An optional RAID adapter is available for purchase.

- **Systems-management capabilities**

The server comes with an IMM2.1. When the IMM is used with the systems-management software that comes with the server, you can manage the functions of the server locally and remotely. The IMM also provides system monitoring, event recording, and network alert capability. The systems-management connector on the rear of the server is dedicated to the IMM. The dedicated systems-management connector provides additional security by physically separating the management network traffic from the production network. In shared mode, depending on the network environment, the IMM might disconnect from the network for a short time when the server restarts. You can use the Setup Utility to configure the server to use a dedicated systems-management network or a shared network.

- **UEFI-compliant server firmware**

System x Server Firmware (server firmware) offers several features, including Unified Extensible Firmware Interface (UEFI) 2.1 compliance; enhanced reliability, availability, and serviceability (RAS) capabilities; and basic input/output system (BIOS) compatibility support. UEFI replaces the BIOS and defines a standard interface between the operating system, platform firmware, and external devices. UEFI-compliant System x servers are capable of booting UEFI-compliant operating systems, BIOS-based operating systems, and BIOS-based adapters as well as UEFI-compliant adapters.

**Note:** The server does not support DOS (Disk Operating System).

- **VMware ESXi embedded hypervisor**

An optional USB flash device or SD card with VMware ESXi embedded hypervisor software is available for purchase. Hypervisor is virtualization software that enables multiple operating systems to run on a host system at the same time. The USB embedded hypervisor flash device can be installed in USB hypervisor connector on the system board. The SD card can be inserted into the SD adapter. For more information about using the embedded hypervisor, see “Using the embedded hypervisor” on page 55.

- **Enterprise X-Architecture technology**

X-Architecture technology combines proven, innovative Lenovo designs to make your Intel-processor-based server powerful, scalable, and reliable.

---

## Reliability, availability, and serviceability

Three important computer design features are reliability, availability, and serviceability (RAS). The RAS features help to ensure the integrity of the data that is stored in the server, the availability of the server when you need it, and the ease with which you can diagnose and correct problems.

Your server has the following RAS features:

- 3-year parts and 3-year labor limited warranty (Machine Type 5120, 5128, 5133, 5135, 5136, and 5139)
- 24-hour support center
- Automatic error retry and recovery
- Automatic restart on nonmaskable interrupt (NMI)
- Automatic restart after a power failure
- Backup basic input/output system switching under the control of the integrated management module (IMM)
- Built-in monitoring for fan, power, temperature, voltage, and power-supply redundancy
- Cable-presence detection on most connectors
- Chipkill memory protection

- Double-device data correction (DDDC) for x4 DRAM technology DIMMs. Ensures that data is available on a single x4 DRAM DIMM after a hard failure of up to two DRAM DIMMs. One x4 DRAM DIMM in each rank is reserved as a spare device.
- Diagnostic support for ServeRAID and Ethernet adapters
- Error codes and messages
- Error correcting code (ECC) L3 cache and system memory
- Full Array Memory Mirroring (FAMM) redundancy
- Hot-swap cooling fans with speed-sensing capability
- Hot-swap hard disk drives
- LCD system information display panel (available on some models) and operator information panel
- Integrated Management Module (IMM)
- LCD system information display panel (available on some models) for memory DIMMs, microprocessors, hard disk drives, solid state drives, power supplies, and fans
- Memory mirroring and memory sparing support
- Memory error correcting code and parity test
- Memory down sizing (non-mirrored memory). After a restart of the server after the memory controller detected a non-mirrored uncorrectable error and the memory controller cannot recover operationally, the IMM logs the uncorrectable error and informs POST. POST logically maps out the memory with the uncorrectable error, and the server restarts with the remaining installed memory.
- Menu-driven setup, system configuration, and redundant array of independent disks (RAID) configuration programs
- Microprocessor built-in self-test (BIST), internal error signal monitoring, internal thermal trip signal monitoring, configuration checking, and microprocessor and voltage regulator module failure identification through LCD system information display panel (if available).
- Nonmaskable interrupt (NMI) button
- Parity checking on the small computer system interface (SCSI) bus and PCI-E and PCI buses
- Power management: Compliance with Advanced Configuration and Power Interface (ACPI)
- Power-on self-test (POST)
- Predictive Failure Analysis (PFA) alerts on memory, microprocessors, SAS/SATA hard disk drives or solid state drives, fans, power supplies, and VRM
- Redundant Ethernet capabilities with failover support
- Redundant hot-swap power supplies and redundant hot-swap fans
- Redundant network interface card (NIC) support
- Remind button to temporarily turn off the system-error LED
- Remote system problem-determination support
- ROM-based diagnostics
- ROM checksums
- Serial Presence Detection (SPD) on memory, VPD on system board, power supply, and hard disk drive or solid state drive backplanes, microprocessor and memory expansion tray, and Ethernet cards
- Single-DIMM isolation of excessive correctable error or multi-bit error by the Unified Extensible Firmware Interface (UEFI)
- Solid state drives
- Standby voltage for system-management features and monitoring
- Startup (boot) from LAN through remote initial program load (RIPL) or dynamic host configuration protocol/boot protocol (DHCP/BOOTP)
- System auto-configuring from the configuration menu
- System-error logging (POST and IMM)
- Systems-management monitoring through the Inter-Integrated Circuit (IC) protocol bus
- Uncorrectable error (UE) detection
- Upgradeable POST, Unified Extensible Firmware Interface (UEFI), diagnostics, IMM firmware, and read-only memory (ROM) resident code, locally or over the LAN
- Vital product data (VPD) on microprocessors, system board, power supplies, and SAS/SATA (hot-swap hard disk drive or solid state drive) backplane
- Wake on LAN capability

## Server controls, LEDs, and power

This section describes the controls and light-emitting diodes (LEDs) and how to turn the server on and off.

For the locations of other LEDs on the system board, see “System-board LEDs” on page 33.

### Front view

The following illustrations show the controls, LEDs, and connectors on the front of your server model.

**Note:** \* in the following illustrations indicates optional hardware components.

2.5-inch hard disk drive server model.

- 8 hard-disk drive configuration / 16 hard-disk drive configuration front view

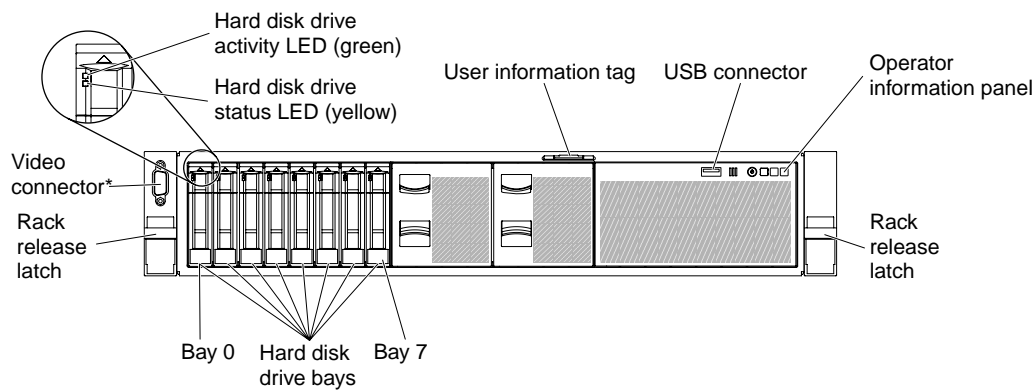

Figure 9. 8 hard-disk drive configuration / 16 hard-disk drive configuration 1

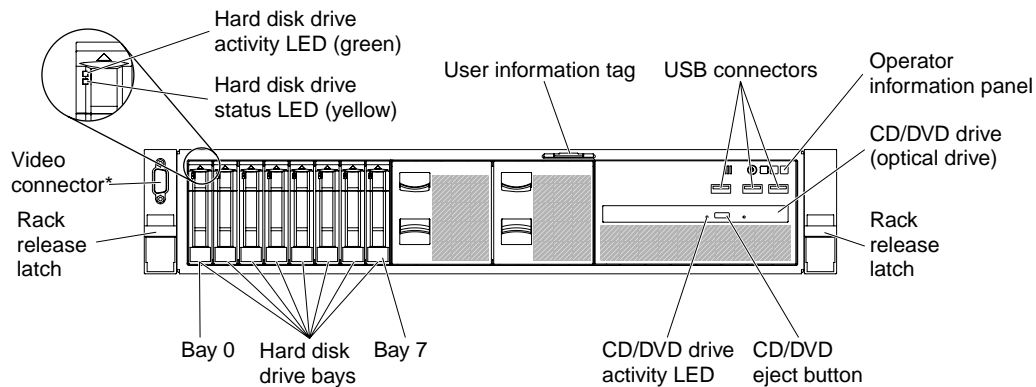

Figure 10. 8 hard-disk drive configuration / 16 hard-disk drive configuration 2: with USB connectors and optical drive

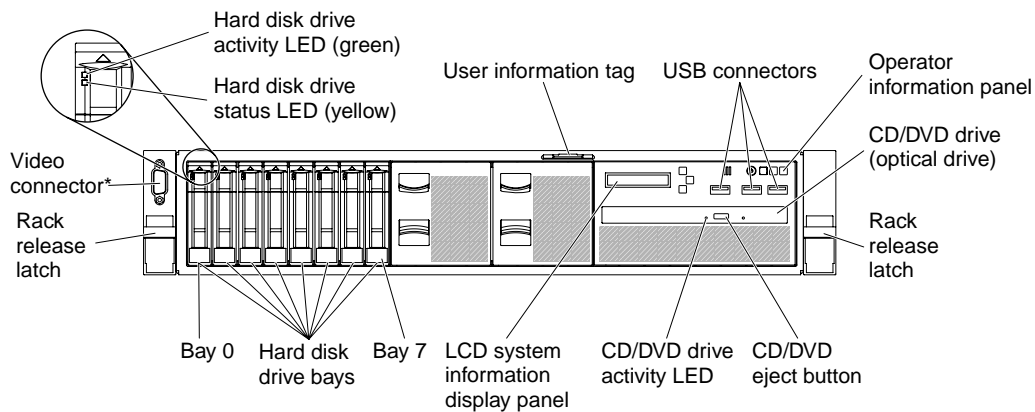

Figure 11. 8 hard-disk drive configuration / 16 hard-disk drive configuration 3: with LCD system information display panel, USB connectors, and optical drive

- 24 hard-disk drive configuration front view

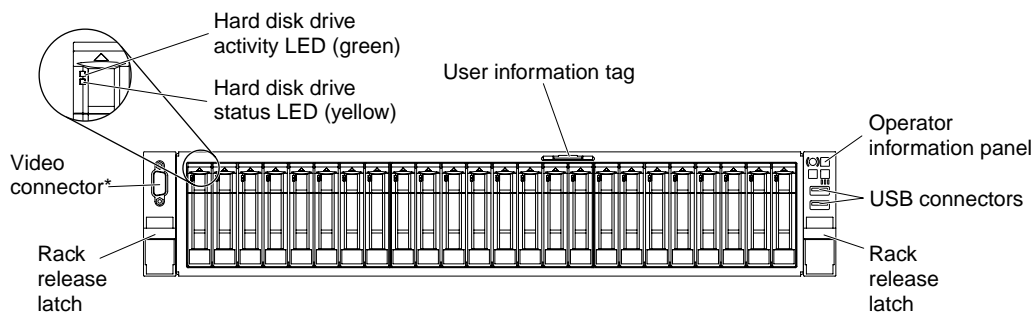

Figure 12. 24 hard-disk drive configuration front view

3.5-inch hard disk drive server model.

- 8 hard-disk drive configuration front view

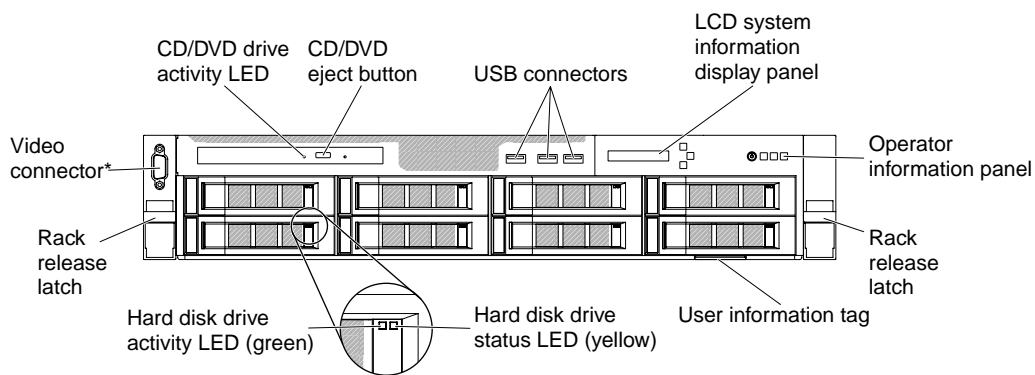

Figure 13. 8 hard-disk drive configuration front view

- 12 hard-disk drive configuration front view

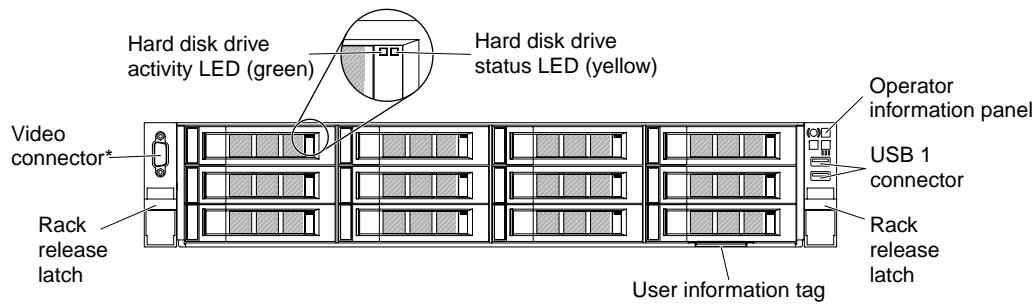

Figure 14. 12 hard-disk drive configuration front view

- **Rack release latches:** Press the latches on each front side of the server to slide the server out from the rack enclosure.
- **Hard disk drive activity LEDs:** These green LEDs are on all hot swap drives.
  - When this LED is flashing, it indicates that the drive is actively reading or writing data.
  - For SAS and SATA drives, this LED is off when the drive is powered but not active.
  - For NVMe (PCIe SSD) solid state drives, this LED is on solid when the drive is powered but not active.
- **Hard disk drive status LEDs:** This LED is used on hot-swap SAS or SATA hard disk drives. When this LED is lit, it indicates that the drive has failed. If an optional ServeRAID controller is installed in the server, when this LED is flashing slowly (one flash per second), it indicates that the drive is being rebuilt. When the LED is flashing rapidly (three flashes per second), it indicates that the controller is identifying the drive.
- **Optional DVD eject button:** Press this button to release a DVD or CD from the optional DVD drive.
- **Optional DVD drive activity LED:** When this LED is lit, it indicates that the optional DVD drive is in use.
- **Operator information panel:** This panel contains controls and LEDs that provide information about the status of the server. For information about the controls and LEDs on the operator information panel, see “Operator information panel” on page 20.
- **Video connector:** Connect a monitor to this connector. The video connectors on the front (optional) and rear of the server can be used simultaneously.

**Note:** The maximum video resolution is 1600 x 1200 at 75 Hz.

- **USB connectors:** Connect a USB device, such as a USB mouse or keyboard to any of these connectors.

## Operator information panel

The following illustration shows the controls and LEDs on the operator information panel.

Operator information panel

- Type 1

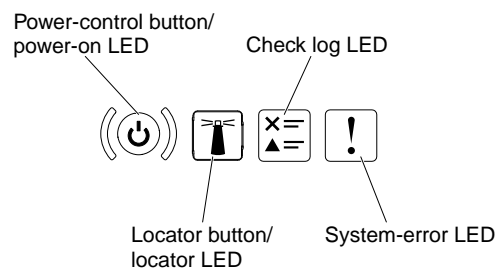

Figure 15. Operator information panel



- Type 2

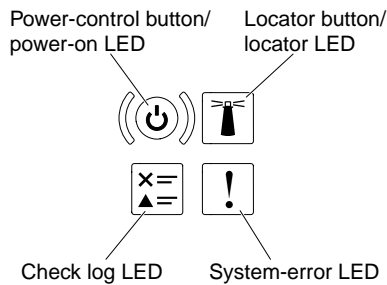

Figure 16. Operator information panel

- **Power-control button and power-on LED:** Press this button to turn the server on and off manually. The states of the power-on LED are as follows:
  - Off:** Power is not present or the power supply, or the LED itself has failed.
  - Flashing rapidly (4 times per second):** The server is turned off and is not ready to be turned on. The power-control button is disabled. This will last approximately 5 to 10 seconds.
  - Flashing slowly (once per second):** The server is turned off and is ready to be turned on. You can press the power-control button to turn on the server.
  - Lit:** The server is turned on.
- **System-locator button/LED:** Use this blue LED to visually locate the server among other servers. This LED is also used as a presence detection button. You can use Lenovo XClarity Administrator to light this LED remotely.
- **Check log LED:** When this yellow LED is lit, it indicates that a system error has occurred. Check the event log for additional information. See “Event logs” on page 73 for more information about event logs.
- **System-error LED:** When this yellow LED is lit, it indicates that a system error has occurred. A system-error LED is also on the rear of the server. An LED on the LCD system information display panel (if available), the operator information panel or on the system board is also lit to help isolate the error. This LED is controlled by the IMM.

## LCD system information display panel

Use this information for an overview of the LCD system information display panel, which displays various types of information about the server.

**Note:** The LCD system information display panel is available only on some models.

The LCD system information display panel is on the front of the server. The LCD system information display panel enables you to have quick access to system status, firmware, network, and health information. The following illustration shows the controls on the LCD system information display panel.

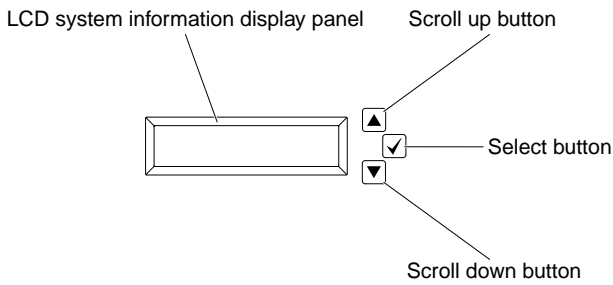

Figure 17. LCD system information display panel

- **Scroll up button:** Press this button to scroll up or scroll to the left in the main menu to locate and select the system information that you want displayed.
- **Select button:** Press this button to make your selection from the menu options.
- **Scroll down button:** Press this button to scroll down or scroll to the right in the main menu to location and select the system information that you want displayed.

The following is an illustration of the LCD system information display panel menu options flow.

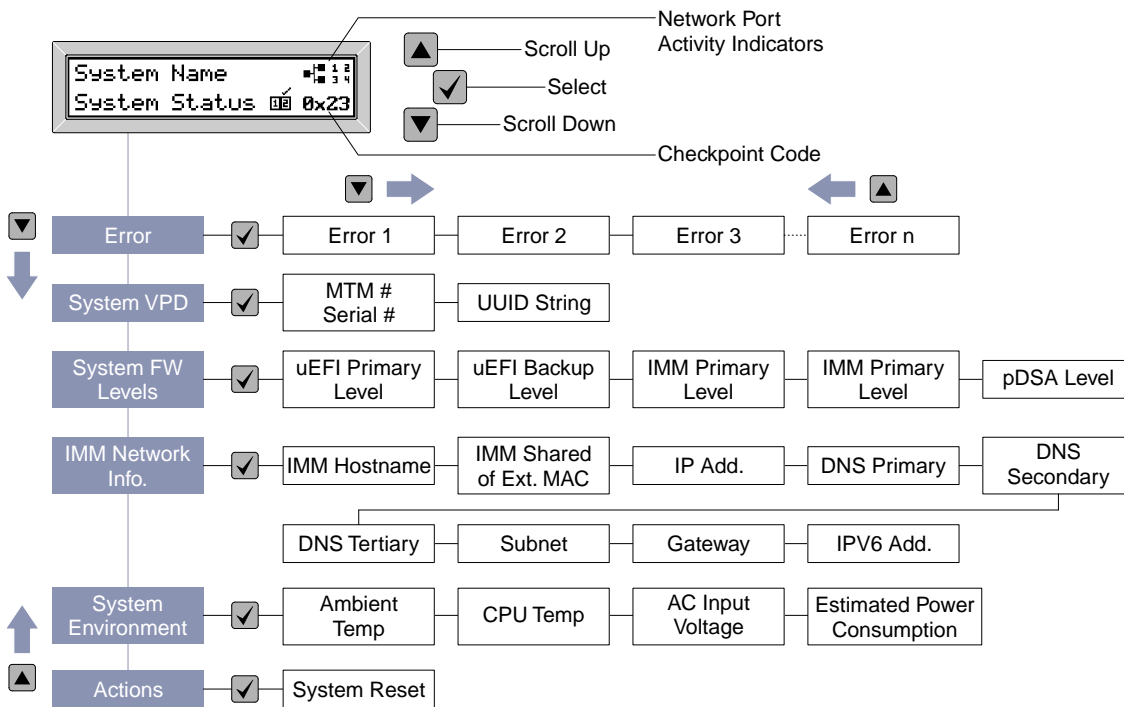

Figure 18. LCD system information display panel menu options flow

The following is an example of the information that you will see on the display panel. This example shows the layout of the information in the main menu when the debug feature is enabled.

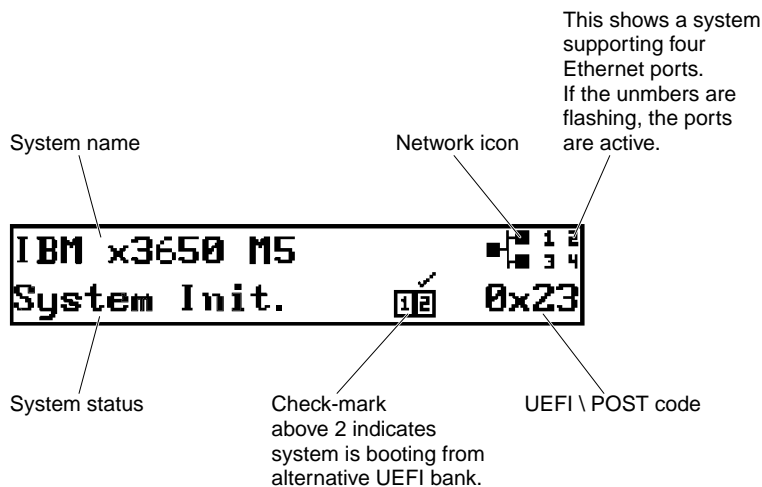

Figure 19. Main menu

When you navigate through the hierarchy of the menu options on the LCD system information display panel, the display panel shows the information for that option and the up and down arrows appear on the side of the display panel. When you get to the bottom of the hierarchy of the menu options, only the up arrow will be available. When you are at the top of the hierarchy of the menu options, only the down arrow will be available.

For the errors submenu set, if only one error occurs, the LCD display panel will display that error. If more than one error occurs, the LCD display panel displays the number of errors that have occurred. If no errors occur, the no error menu will be available for navigation.

To move within the menu options, use the Scroll up or Scroll down buttons, then the Select button to enter a submenu set.

The LCD system information display panel displays the following types of information about the server:

- IMM system error log (SEL)

**Note:** The Scroll Down button will only function for this menu option if errors have occurred. A list of current errors reported by the system will be displayed. To see the system error log (SEL) and get the complete list of errors, go to the IMM web page ( see “Logging in to the Web interface” on page 54).

- System VPD information:
  - Machine type and serial number
  - Universal Unique Identifier (UUID) string
- System firmware levels:
  - UEFI code level
  - IMM code level
  - pDSA code level
- IMM network information:
  - IMM hostname
  - IMM dedicated MAC address

**Note:** Only the MAC address that is currently in use is displayed (dedicated or shared)

- IMM shared MAC address
- IP v4 information

- IP v6 address
- System environmental information:
  - Ambient temperature
  - CPU temperature
  - AC input voltage
  - Estimated power consumption

## Rear view

The following illustration shows the connectors on the rear of the server.

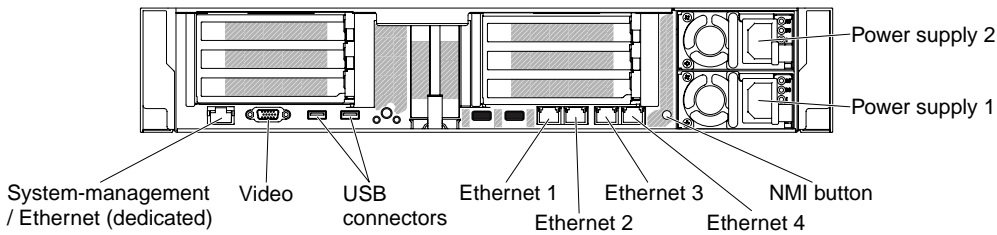

Figure 20. Rear view

- **NMI button:** Press this button to force a nonmaskable interrupt to the microprocessor. It allows you to blue screen the server and take a memory dump (use this button only when directed by the service support). You might have to use a pen or the end of a straightened paper clip to press the button. The NMI button is in the lower left-hand corner on the rear of the server.
- **Power connector:** Connect the power cord to this connector.
 

**Note:** Power supply 1 is the default/primary power supply. If power supply 1 fails, you must replace it immediately.
- **Video connector:** Connect a monitor to this connector. The video connectors on the front and rear of the server can be used simultaneously.
 

**Note:** The maximum video resolution is 1600 x 1200 at 75 Hz.
- **Two USB 3.0 connectors :** Connect a USB device, such as a USB mouse or keyboard to any of these connectors.
- **Systems-management Ethernet connector:** Use this connector to connect the server to a network for full systems-management information control. This connector is used only by the IMM2.1. A dedicated management network provides additional security by physically separating the management network traffic from the production network. You can use the Setup Utility to configure the server to use a dedicated systems management network or a shared network. See Using the Setup Utility in the *Problem Determination and Service Guide* for more information.
- **Ethernet connectors:** Use either of these connectors to connect the server to a network. When you enable shared Ethernet for IMM2.1 in the Setup Utility, you can access the IMM2.1 using either the Ethernet 1 or the system-management Ethernet (default) connector. See Using the Setup Utility for more information.
- **Serial connector (optional):** Connect a 9-pin serial device to this connector. The serial port is shared with the IMM2.1. The IMM2.1 can take control of the shared serial port to redirect serial traffic, using Serial over LAN (SOL).

The following illustration shows the LEDs on the rear of the server.

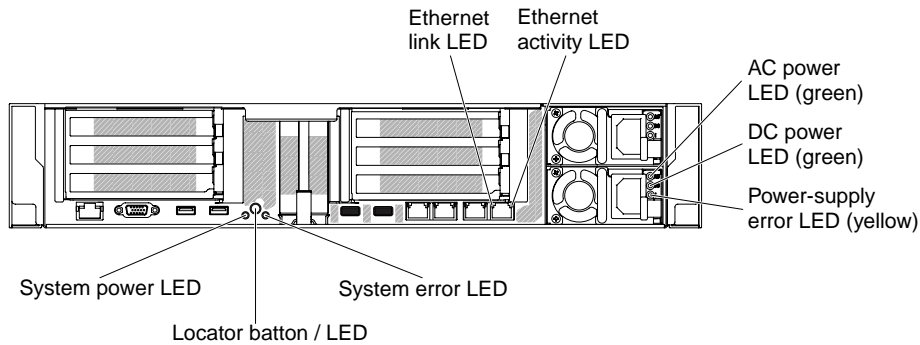
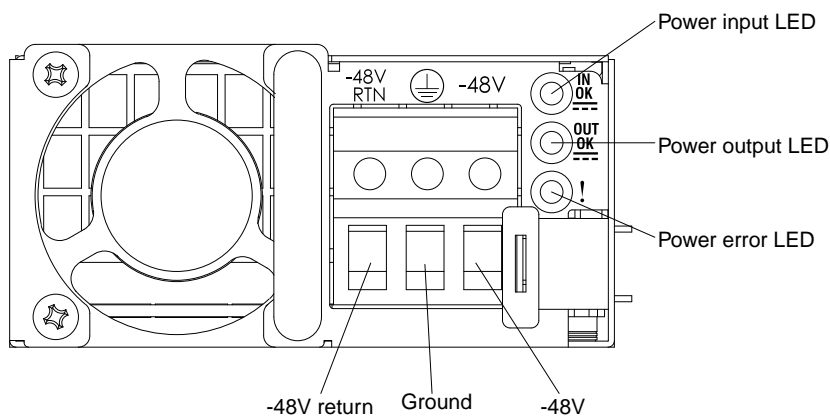

Figure 21. LEDs rear view

The following illustration shows the LEDs on a dc power supply.



- **Ethernet activity LEDs:** When these LEDs are lit, they indicate that the server is transmitting to or receiving signals from the Ethernet LAN that is connected to the Ethernet port.
- **Ethernet link LEDs:** When these LEDs are lit, they indicate that there is an active link connection on the 10BASE-T, 100BASE-TX, or 1000BASE-TX interface for the Ethernet port.
- **AC power LED:** Each hot-swap ac power supply has an ac power LED. When the ac power LED is lit, it indicates that sufficient power is coming into the power supply through the power cord. During typical operation, the ac power LED is lit. For any other combination of LEDs, see “AC power-supply LEDs” on page 69.
- **DC power LED:** Each hot-swap ac power supply has a dc power LED. When the dc power LED is lit, it indicates that the power supply is supplying adequate dc power to the system. During typical operation, both the ac and dc power LEDs are lit. For any other combination of LEDs, see “DC power-supply LEDs” on page 70.
- **IN OK power LED:** Each hot-swap dc power supply has an IN OK power LED. When the IN OK power LED is lit, it indicates that sufficient power is coming into the power supply through the power cord. During typical operation, both the IN OK and OUT OK power LEDs are lit. For any other combination of LEDs, see “DC power-supply LEDs” on page 70.
- **OUT OK power LED:** Each hot-swap dc power supply has an OUT OK power LED. When the OUT OK power LED is lit, it indicates that the power supply is supplying adequate dc power to the system. During typical operation, both the IN OK and OUT OK power LEDs are lit. For any other combination of LEDs, see “DC power-supply LEDs” on page 70.
- **Power-supply error LED:** When the power-supply error LED is lit, it indicates that the power supply has failed.

**Note:** Power supply 1 is the default/primary power supply. If power supply 1 fails, you must replace the power supply immediately.

- **Power-on LED:** When this LED is lit and not flashing, it indicates that the server is turned on. The states of the power-on LED are as follows:

**Off:** Power is not present, or the power supply or the LED itself has failed.

**Flashing rapidly (4 times per second):** The server is turned off and is not ready to be turned on. The power-control button is disabled. This will last approximately 5 to 10 seconds.

**Flashing slowly (once per second):** The server is turned off and is ready to be turned on. You can press the power-control button to turn on the server.

**Lit:** The server is turned on.

- **System-locator LED:** Use this LED to visually locate the server among other servers. You can use Lenovo XClarity Administrator to light this LED remotely.
- **System-error LED:** When this LED is lit, it indicates that a system error has occurred. An LED on the LCD system information display panel (if available) is also lit to help isolate the error.

## PCI riser-card adapter expansion slot locations

The section shows the PCI expansion slot connector locations on the server.

Based on the server configuration, the locations of the adapter expansion slots from the rear of the server may be either of the following.

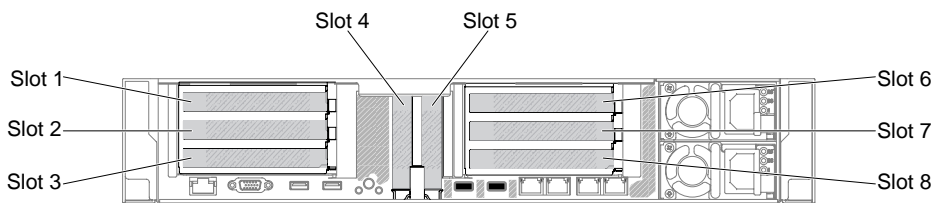

Figure 22. PCI riser-card adapter expansion slot locations

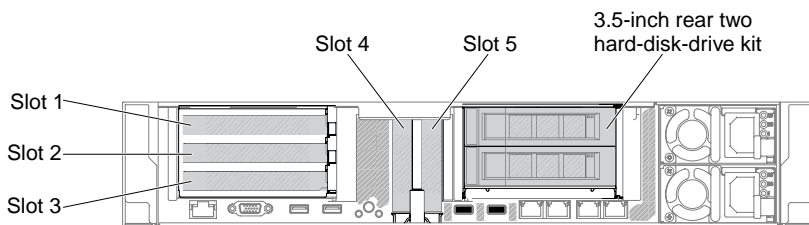

Figure 23. PCI riser-card adapter expansion slot locations

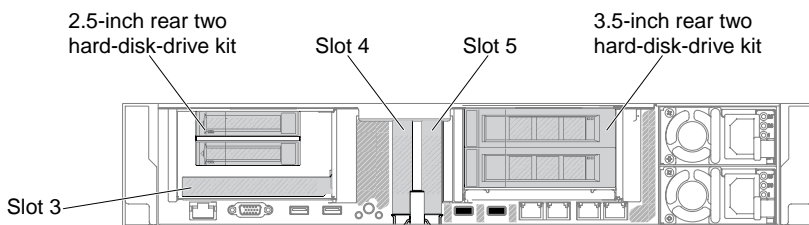

Figure 24. PCI riser-card adapter expansion slot locations

# Server components

The following illustration shows the major components in the server.

The illustrations in this document might differ slightly from your hardware.

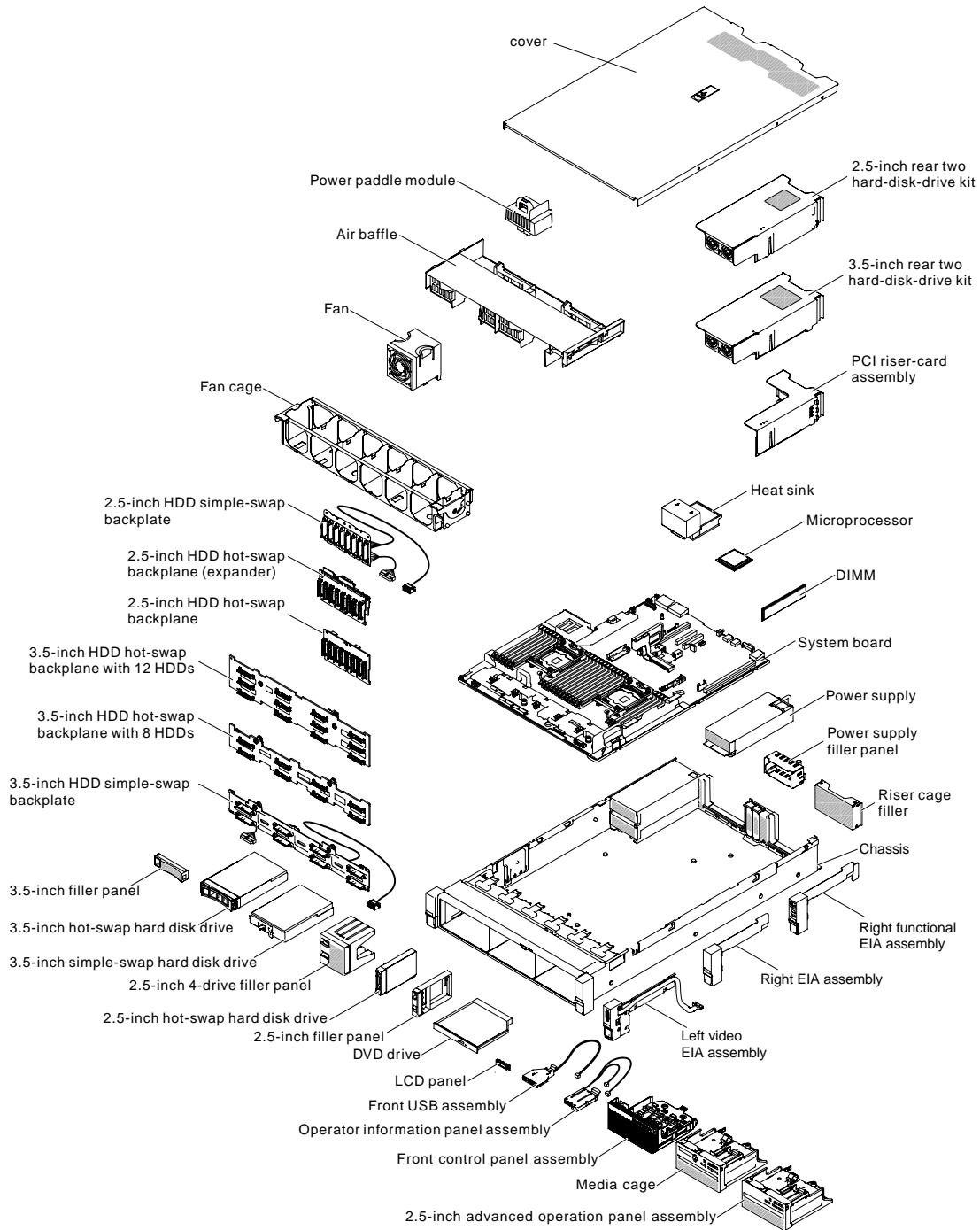

Figure 25. Server components

Blue on a component indicates touch points, where you can grip the component to remove it from or install it in the server, open or close a latch, and so on.

Orange on a component or an orange label on or near a component indicates that the component can be hot-swapped, which means that if the server and operating system support hot-swap capability, you can remove or install the component while the server is running. (Orange can also indicate touch points on hot-swap components.) See the instructions for removing or installing a specific hot-swap component for any additional procedures that you might have to perform before you remove or install the component.

## System-board internal connectors

The following illustration shows the internal connectors on the system board.

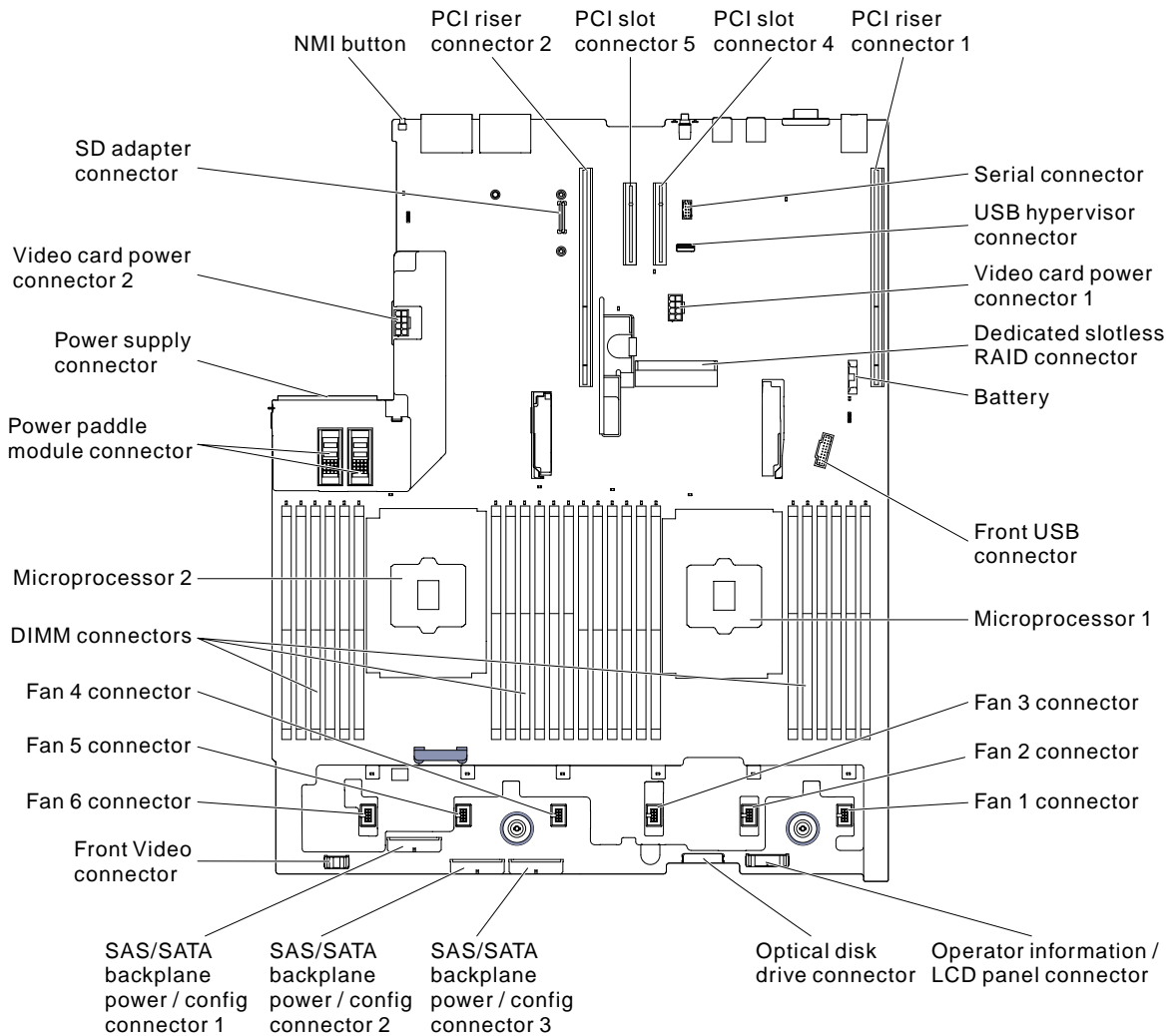

Figure 26. System-board internal connectors

## System-board external connectors

The following illustration shows the external connectors on the system board.



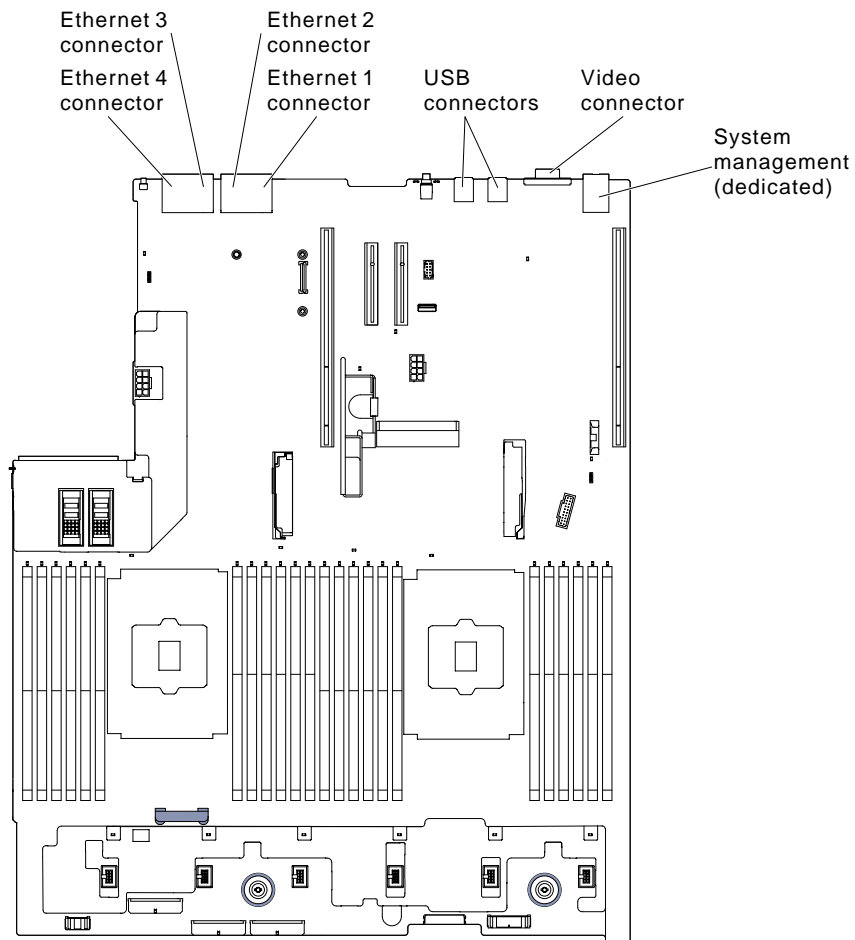

Figure 27. System-board external connectors

### System-board optional-device connectors

The following illustration shows the connectors on the system board for the optional devices.

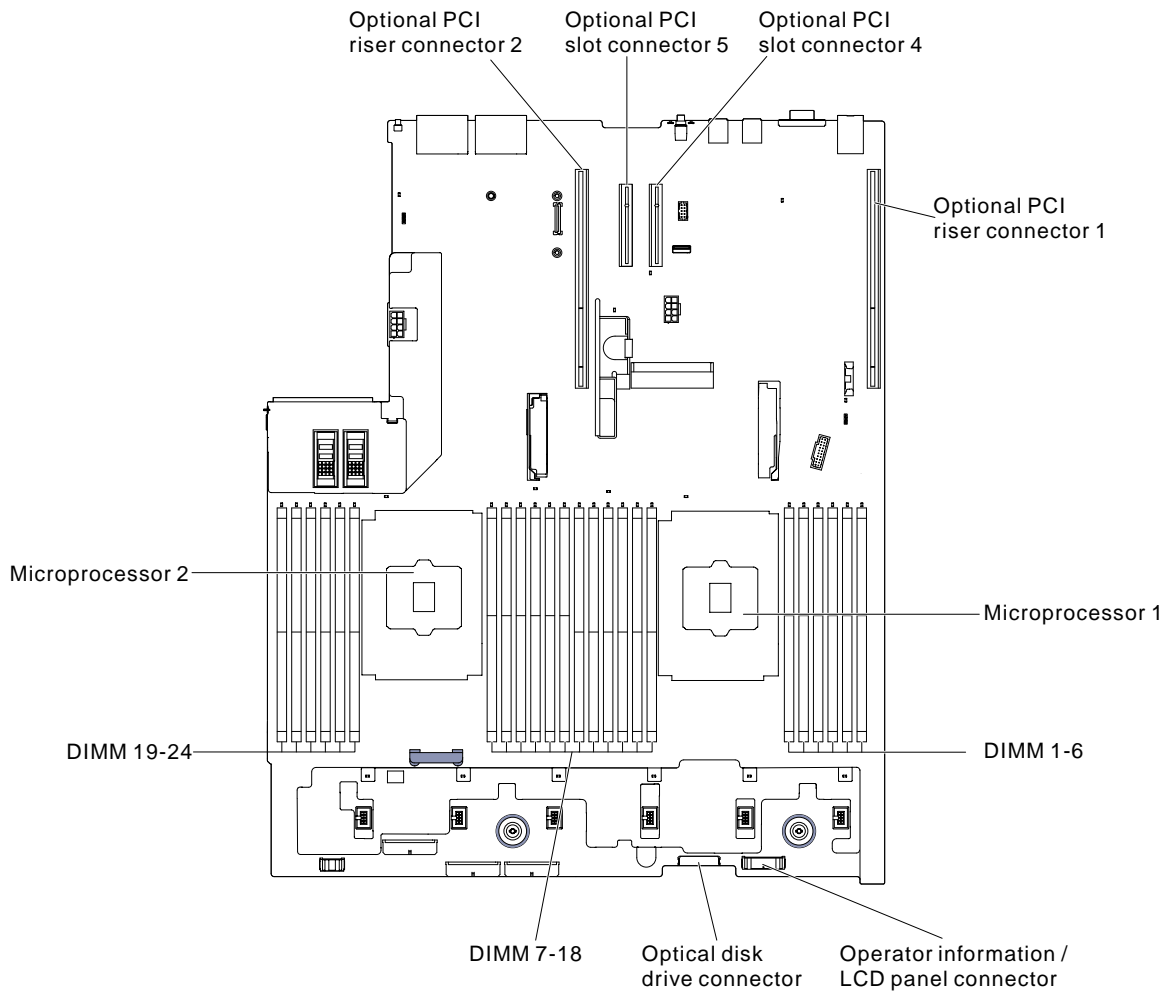

Figure 28. System-board optional-device connectors

### System-board switches, jumpers, and buttons

The following illustration shows the location of the switches, jumpers, and buttons on the server.

**Note:** If there is a clear protective sticker on the top of the switch blocks, you must remove and discard it to access the switches.

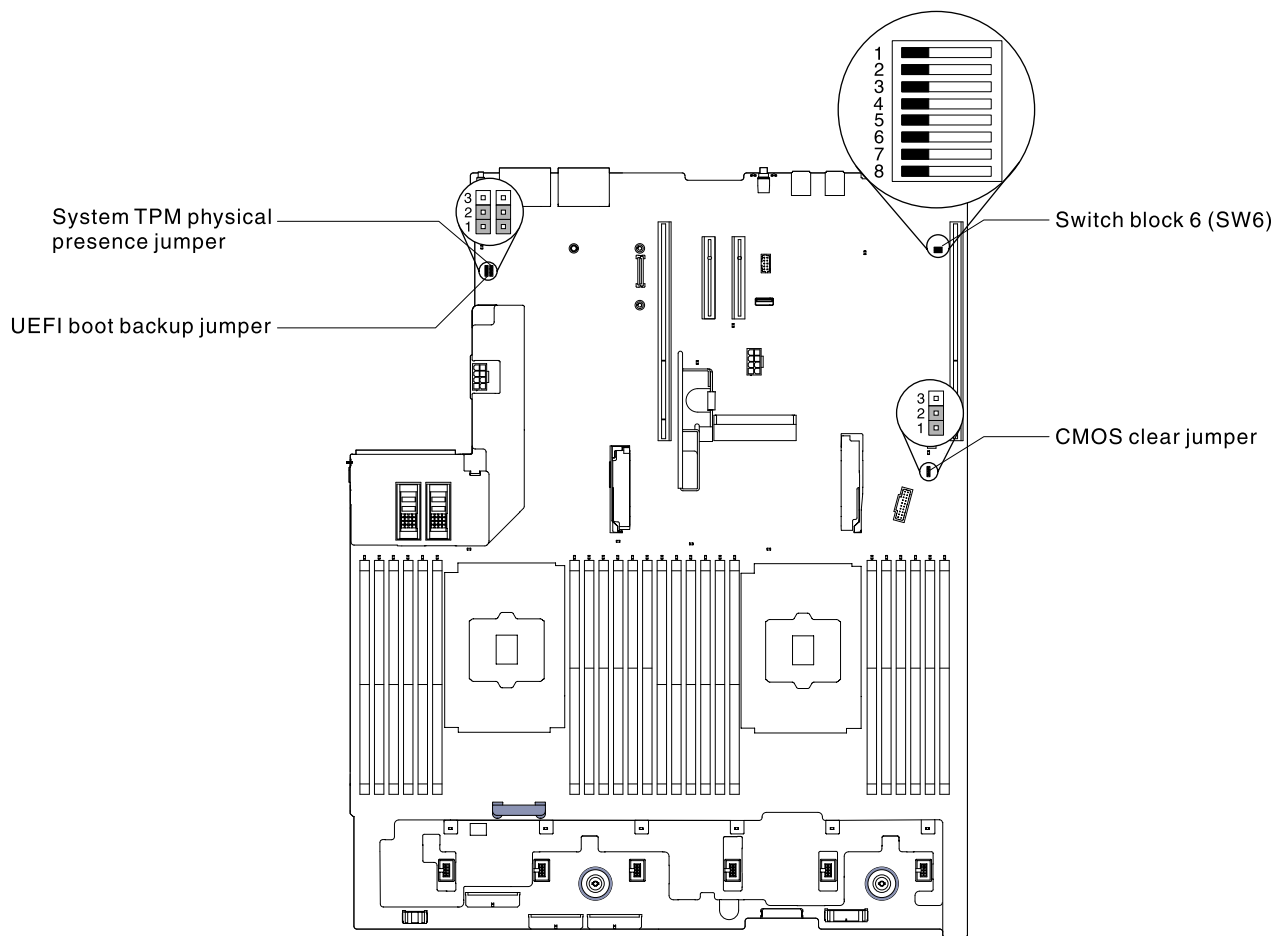

Figure 29. System-board switches, jumpers, and buttons

The following table describes the jumpers on the system board.

Table 2. System board jumpers

Jumper number	Jumper name	Jumper setting
J7	System TPM physical presence jumper	<ul style="list-style-type: none"> <li>Pins 1 and 2: Normal (default).</li> <li>Pins 2 and 3: Indicates a physical presence to the system TPM.</li> </ul>
J11	CMOS clear jumper	<ul style="list-style-type: none"> <li>Pins 1 and 2: Normal (default).</li> <li>Pins 2 and 3: Clears the real-time clock (RTC) registry.</li> </ul>

Table 2. System board jumpers (continued)

Jumper number	Jumper name	Jumper setting
J15	UEFI boot backup jumper	<ul style="list-style-type: none"> <li>Pins 1 and 2: Normal (default). Loads the primary server firmware ROM page.</li> <li>Pins 2 and 3: Loads the secondary (backup) server firmware ROM page.</li> </ul>
<p><b>Notes:</b></p> <ol style="list-style-type: none"> <li>If no jumper is present, the server responds as if the pins are set to the default.</li> <li>Changing the position of the UEFI boot backup jumper (J15) from pins 1 and 2 to pins 2 and 3 before the server is turned on alters which flash ROM page is loaded. Do not change the jumper pin position after the server is turned on. This can cause an unpredictable problem.</li> </ol>		

The following table describes the functions of the SW6 switch block on the system board.

Table 3. System board SW6 switch block definition

Switch number	Default position	Description
1	Off	Reserved.
2	Off	Power-on password override. Changing the position of this switch bypasses the power-on password check the next time the server is turned on and starts the Setup Utility so that you can change or delete the power-on password. You do not have to move the switch back to the default position after the power-on password is overridden. Changing the position of this switch does not affect the administrator password check if an administrator password is set.
3	Off	Reserved.
4	Off	Reserved.
5	Off	Reserved.
6	Off	Reserved.

**Important:**

- Before you change any switch settings or move any jumpers, turn off the server; then, disconnect all power cords and external cables. Review the information in “Safety” on page v, “Installation guidelines” on page 287, “Handling static-sensitive devices” on page 289, and “Turning off the server” on page 40.
- Any system-board switch or jumper block that is not shown in the illustrations in this document are reserved.

The following table describes the functions of the button on the system board.

Table 4. Button on the server

Button name	Function
Force NMI button	This button is on the rear of the server. Press this button to force a nonmaskable interrupt to the microprocessor. You might have to use a pen or the end of a straightened paper clip to press the button. You can also use it to force a blue-screen memory dump (use this button only when you are directed to do so by Lenovo Support).

## System-board LEDs

The following illustration shows the light-emitting diodes (LEDs) on the system board.

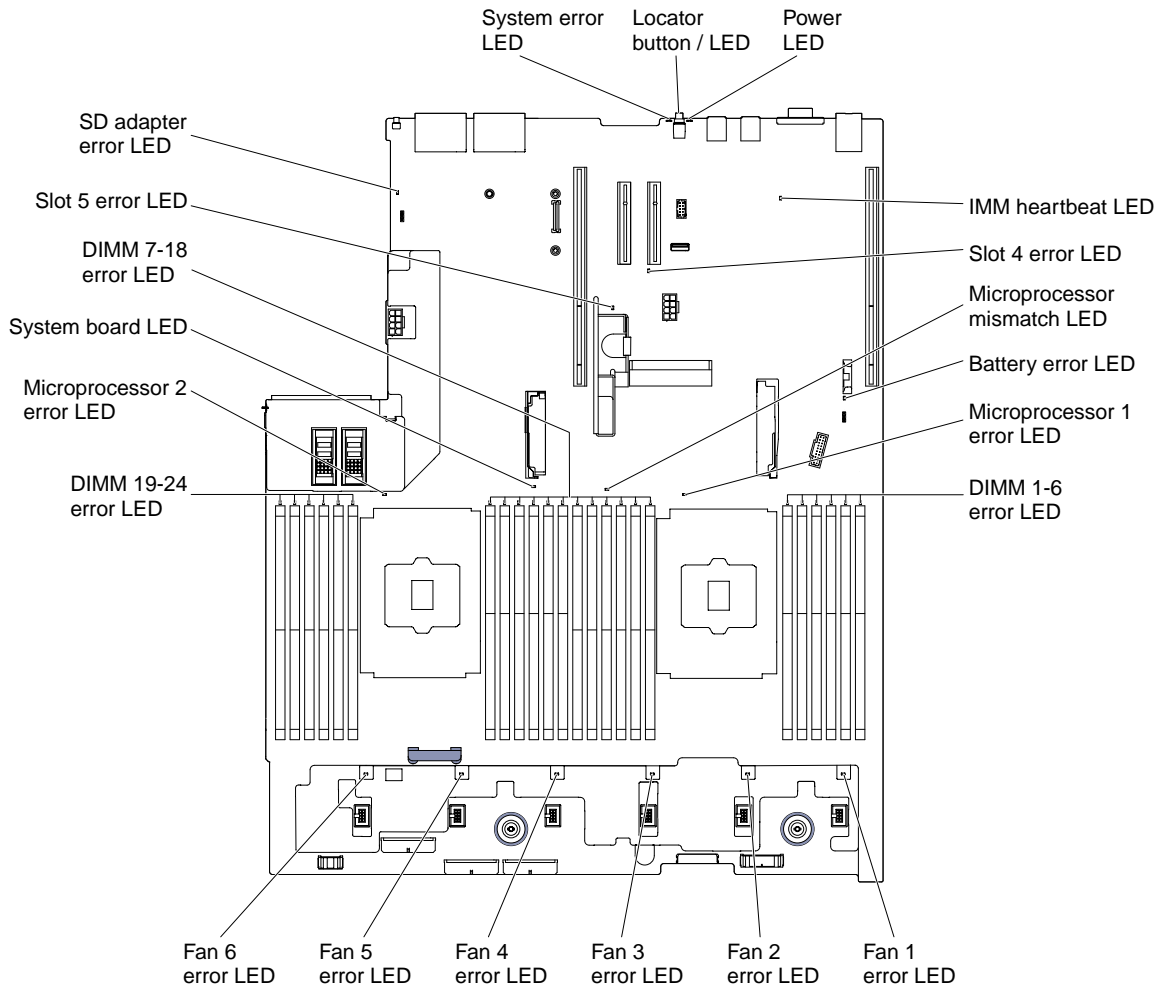

Figure 30. System-board LEDs

## Riser-card adapter expansion slot connectors

The following illustration shows the respective expansion slot connectors.

- Riser-card assembly 1
  - Type 1 PCI riser card

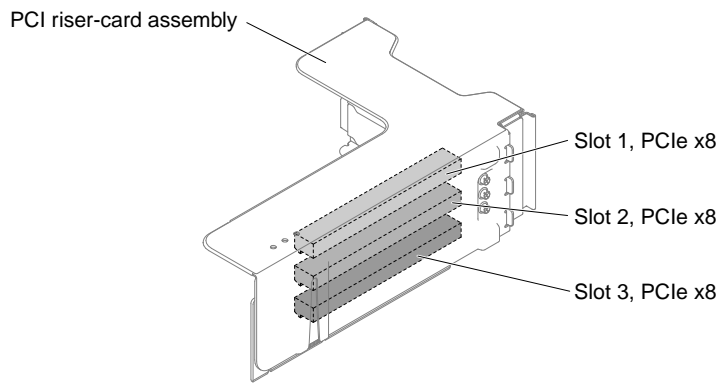

Figure 31. Type 1 PCI riser card

– Type 2 PCI riser card

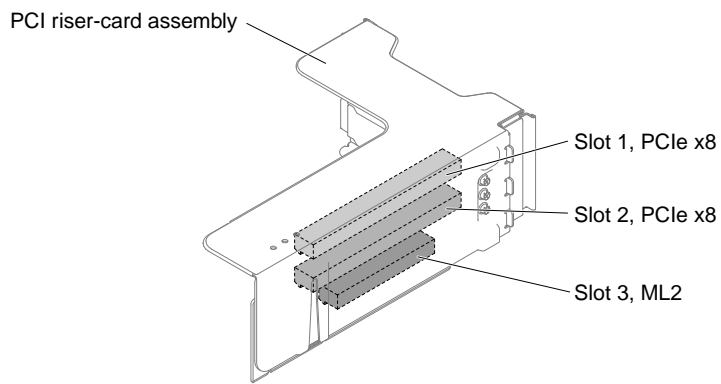

Figure 32. Type 2 PCI riser card

– Type 3 PCI riser card

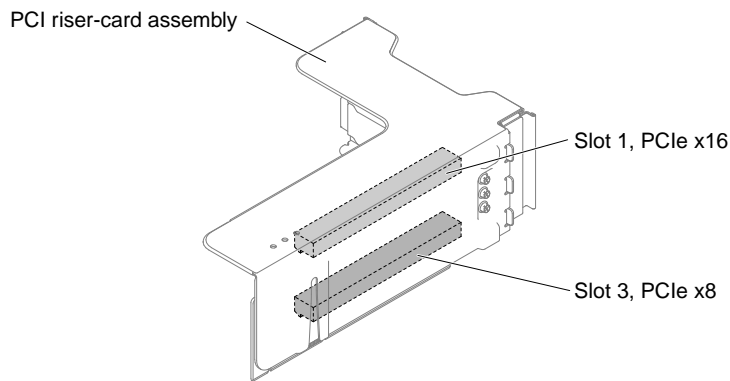

Figure 33. Type 3 PCI riser card

– Type 4 PCI riser card

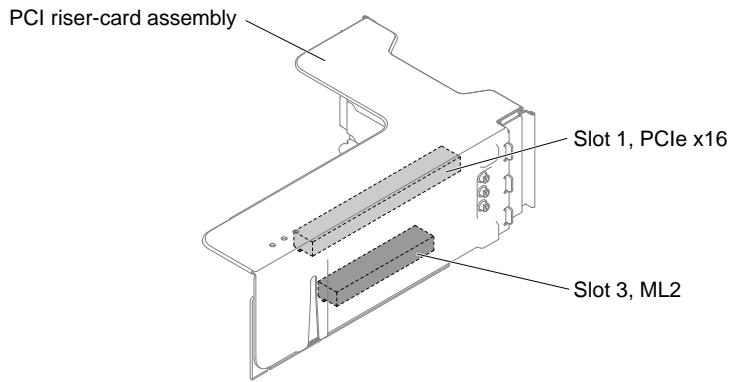

Figure 34. Type 4 PCI riser card

- Riser-card assembly 2
  - Type 5 PCI riser card

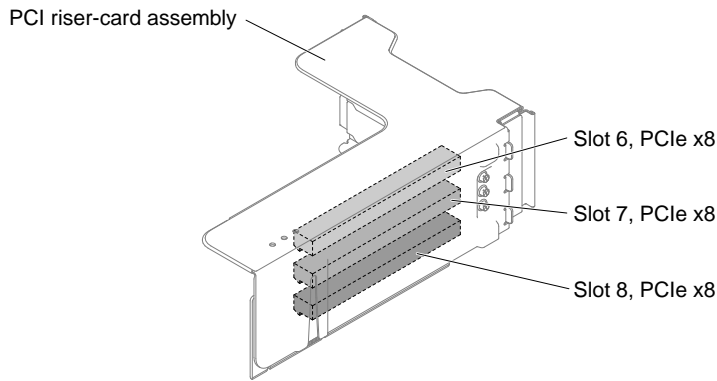

Figure 35. Type 5 PCI riser card

- Type 6 PCI riser card

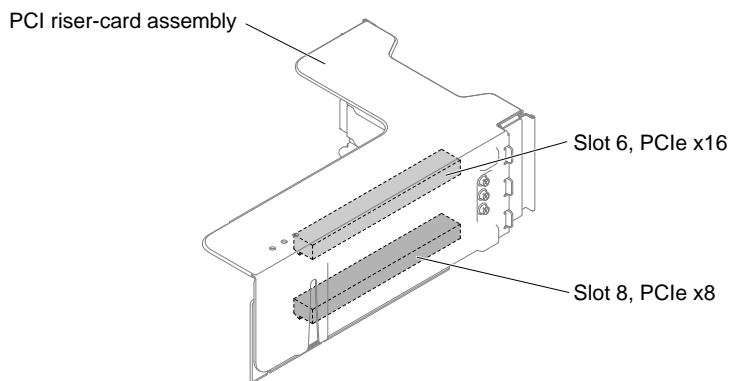

Figure 36. Type 6 PCI riser card

### Riser-card assembly LEDs

The following illustration shows the light-emitting diodes (LEDs) on the PCI riser-card assembly.

**Note:** Error LEDs remain lit only while the server is connected to power.

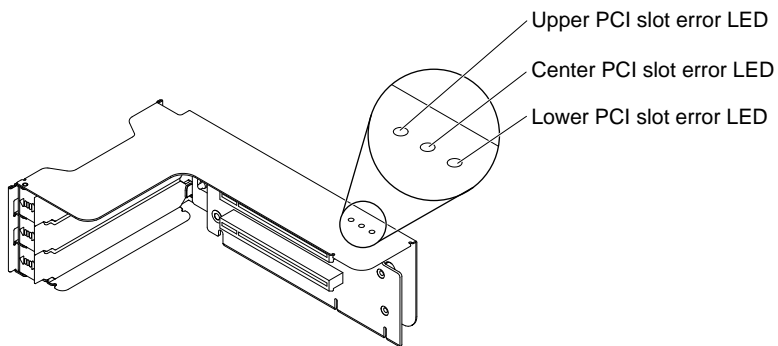

Figure 37. Riser-card assembly LEDs

## 2.5-inch/3.5-inch simple-swap/hot-swap hard disk drive backplate assemblies and backplanes

The following illustration shows the respective 2.5-inch/3.5-inch simple-swap/hot-swap hard disk drive backplate assemblies and backplanes.

- 2.5-inch simple-swap hard disk drive backplate assembly

- Type 1

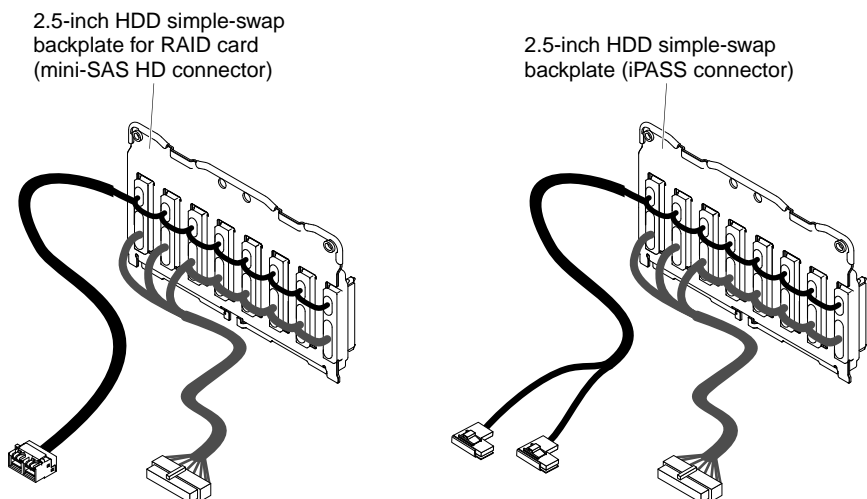
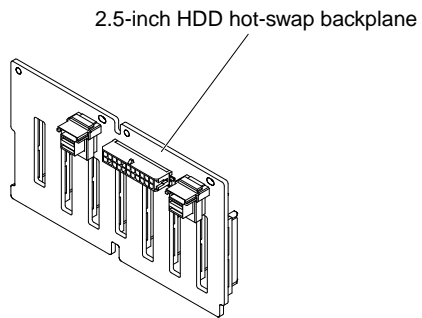

Figure 38. Type 1

- 2.5-inch hot-swap hard disk drive backplanes

- Type 2





2.5-inch HDD hot-swap backplane

Figure 39. Type 2

– Type 3

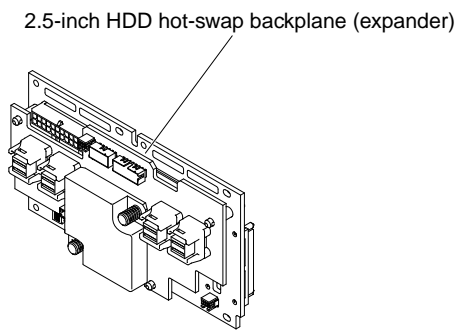

2.5-inch HDD hot-swap backplane (expander)

Figure 40. Type 3

• 3.5-inch simple-swap hard disk drive backplate assembly

– Type 4

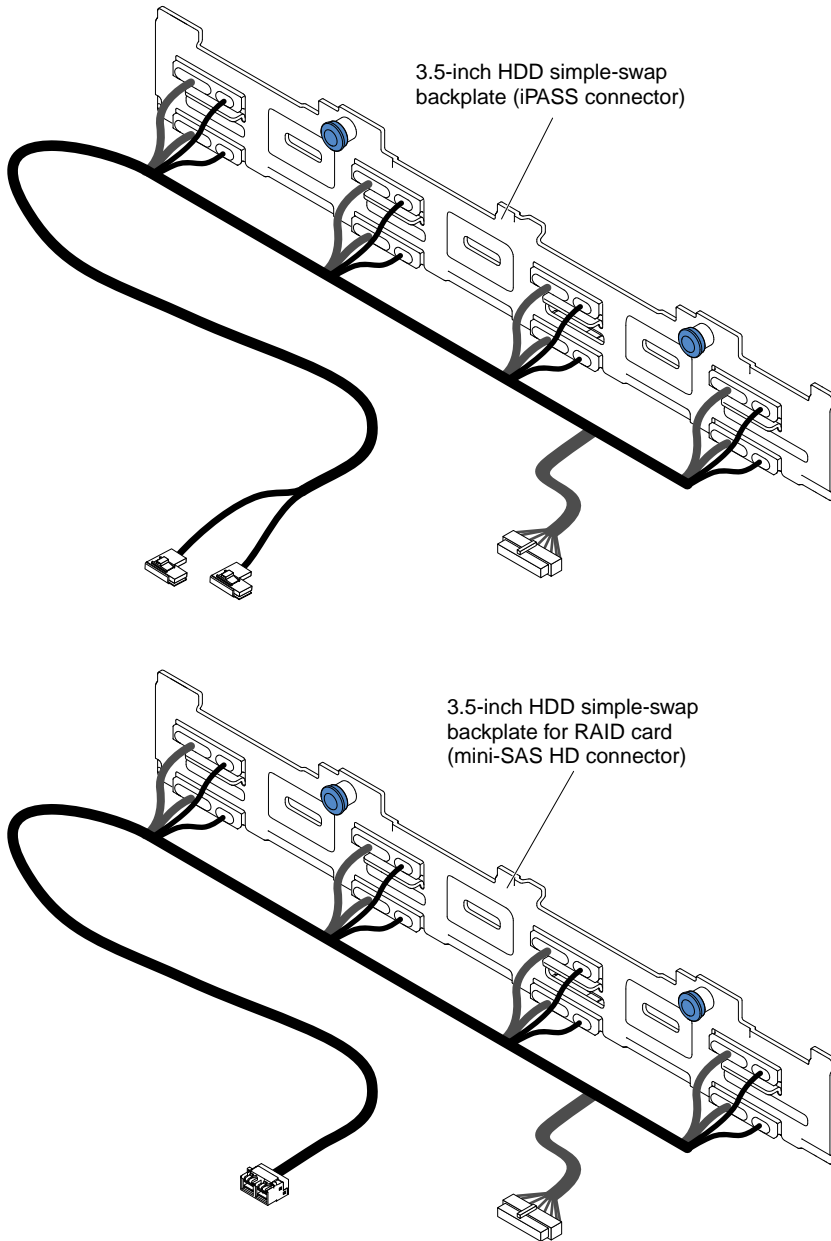

Figure 41. Type 4

- 3.5-inch hot-swap hard disk drive backplanes
  - Type 5

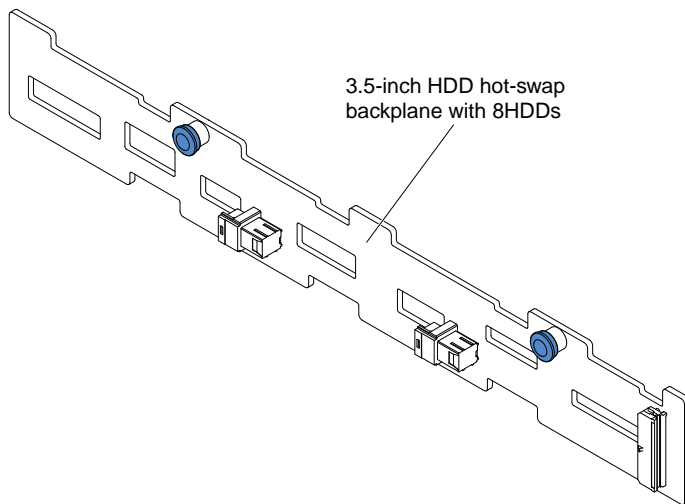

Figure 42. Type 5

– Type 6

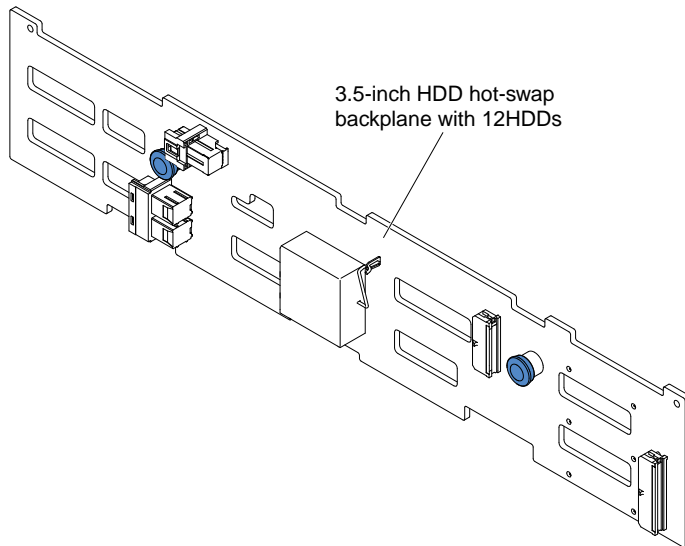

Figure 43. Type 6

## Server power features

When the server is connected to an ac power source but is not turned on, the operating system does not run, and all core logic except for the IMM2 is shut down.

However, the server can respond to requests from IMM2, such as a remote request to turn on the server. The power-on LED flashes to indicate that the server is connected to an ac power source but is not turned on.

### Turning on the server

Use this information to turn on the server.

Approximately 5 seconds after the server is connected to power, one or more fans might start running to provide cooling while the server is connected to power and the power-on button LED will blink quickly. Approximately 5 to 10 seconds after the server is connected to power, the power-control button becomes

active (the power-on LED will blink slowly), and one or more fans might start running to provide cooling while the server is connected to power. You can turn on the server by pressing the power-control button.

The server can also be turned on in any of the following ways:

- If a power failure occurs while the server is turned on, the server will restart automatically when power is restored.
- If your operating system supports the Wake on LAN feature, the Wake on LAN feature can turn on the server.

#### Notes:

1. When 4 GB or more of memory (physical or logical) is installed, some memory is reserved for various system resources and is unavailable to the operating system. The amount of memory that is reserved for system resources depends on the operating system, the configuration of the server, and the configured PCI options.
2. Ethernet 1 connector supports Wake on LAN feature.
3. When you turn on the server with the graphical adapters installed, the logo displays on the screen after approximately 3 minutes. This is normal operation while the system loads.

### Turning off the server

Use this information to turn off the server.

When you turn off the server and leave it connected to power, the server can respond to requests to the service processor, such as a remote request to turn on the server. While the server remains connected to power, one or more fans might continue to run. To remove all power from the server, you must disconnect it from the power source.

Some operating systems require an orderly shutdown before you turn off the server. See your operating-system documentation for information about shutting down the operating system.

#### Statement 5



#### CAUTION:

**The power control button on the device and the power switch on the power supply do not turn off the electrical current supplied to the device. The device also might have more than one power cord. To remove all electrical current from the device, ensure that all power cords are disconnected from the power source.**

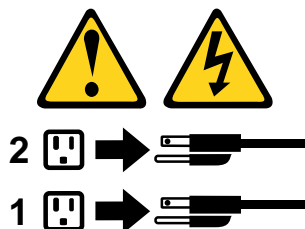

The server can be turned off in any of the following ways:

- You can turn off the server from the operating system, if your operating system supports this feature. After an orderly shutdown of the operating system, the server will turn off automatically.

- You can press the power-control button to start an orderly shutdown of the operating system and turn off the server, if your operating system supports this feature.
- If the operating system stops functioning, you can press and hold the power-control button for more than 4 seconds to turn off the server.
- The server can be turned off by Wake on LAN feature with the following limitation:  
**Note:** When you install any PCI adapter, the power cords must be disconnected from the power source before you remove the PCI Express riser-card assembly. Otherwise, the Wake on LAN feature might not work.
- The IMM2 can turn off the server as an automatic response to a critical system failure.



---

## Chapter 2. Configuration information and instructions

This chapter provides information about updating the firmware and using the configuration utilities.

---

### Updating the firmware

Use this information to update the firmware.

#### Important:

1. Lenovo Storage DX8200 series require specific and verified code levels. Before you update the code, consult Lenovo service technicians or visit Lenovo support Web site to ensure that the latest code level is supported for Storage DX8200 systems.
2. Some cluster solutions require specific code levels or coordinated code updates. If the device is part of a cluster solution, verify that the latest level of code is supported for the cluster solution before you update the code.
3. Before you update the firmware, be sure to back up any data that is stored in the Trusted Platform Module (TPM), in case any of the TPM characteristics are changed by the new firmware. For instructions, see your encryption software documentation.
4. Installing the wrong firmware or device-driver update might cause the server to malfunction. Before you install a firmware or device-driver update, read any readme and change history files that are provided with the downloaded update. These files contain important information about the update and the procedure for installing the update, including any special procedure for updating from an early firmware or device-driver version to the latest version.

You can install code updates that are packaged as an UpdateXpress System Pack or UpdateXpress CD image. An UpdateXpress System Pack contains an integration-tested bundle of online firmware and device-driver updates for your server. Use UpdateXpress System Pack Installer to acquire and apply UpdateXpress System Packs and individual firmware and device-driver updates. For additional information and to download the UpdateXpress System Pack Installer, go to the ToolsCenter for System x and BladeCenter at <https://support.lenovo.com/us/en/documents/LNVO-CENTER> and click **UpdateXpress System Pack Installer**.

When you click an update, an information page is displayed, including a list of the problems that the update fixes. Review this list for your specific problem; however, even if your problem is not listed, installing the update might solve the problem.

Be sure to separately install any listed critical updates that have release dates that are later than the release date of the UpdateXpress System Pack or UpdateXpress image.

The firmware for the server is periodically updated and is available for download on the website. To check for the latest level of firmware, such as the UEFI firmware, device drivers, and IMM2 firmware, go to <http://www.ibm.com/support/fixcentral>.

Download the latest firmware for the server; then, install the firmware, using the instructions that are included with the downloaded files.

When you replace a device in the server, you might have to update the firmware that is stored in memory on the device or restore the pre-existing firmware from a CD or DVD image.

The following list indicates where the firmware is stored:

- UEFI firmware is stored in ROM on the system board.
- IMM2 firmware is stored in ROM on the system board.
- Ethernet firmware is stored in ROM on the Ethernet controller and on the system board.
- ServeRAID firmware is stored in ROM on the system board and the RAID adapter (if one is installed).
- SAS/SATA firmware is stored in ROM on the SAS/SATA controller on the system board.

---

## Configuring the server

The following configuration programs come with the server:

- **Setup Utility**

The Setup Utility is part of the UEFI firmware. Use it to perform configuration tasks such as changing interrupt request (IRQ) settings, changing the startup-device sequence, setting the date and time, and setting passwords. For information about using this program, see “Using the Setup Utility” on page 47.

- **Boot Manager program**

The Boot Manager is part of the UEFI firmware. Use it to override the startup sequence that is set in the Setup Utility and temporarily assign a device to be first in the startup sequence. For more information about using this program, see “Using the Boot Manager” on page 51.

- **ServerGuide Setup and Installation CD**

The ServerGuide program provides software-setup tools and installation tools that are designed for the server. Use this CD during the installation of the server to configure basic hardware features, such as an integrated SAS/SATA controller with RAID capabilities, and to simplify the installation of your operating system. For information about using this CD, see “Using the ServerGuide Setup and Installation CD” on page 45.

- **FastSetup**

FastSetup is a no-cost software tool that helps simplify the maintenance and deployment of selected BladeCenter chassis, servers, and components. The intuitive graphical interface initializes all phases of server setup, including discovery, update, and configuration. Features include templates that enable replication of settings to many servers and automation that reduces hands-on time and user errors. Wizards and other default settings enable customization capabilities. The low-touch, set-once and walk-away feature reduces the hands-on server setup time from days to minutes, particularly for larger deployments. For information about this tool, see <http://www.ibm.com/support/entry/portal/docdisplay?brand=5000008&indocid=TOOL-FASTSET>.

- **Integrated management module II (IMM2)**

Use the IMM2 for configuration, to update the firmware and sensor data record/field replaceable unit (SDR/FRU) data, and to remotely manage a network. For information about using the IMM2, see “Using the integrated management module” on page 51 and the *Integrated Management Module II User's Guide* at [http://publib.boulder.ibm.com/infocenter/systemx/documentation/topic/com.lenovo.sysx.imm2.doc/printable\\_doc.html](http://publib.boulder.ibm.com/infocenter/systemx/documentation/topic/com.lenovo.sysx.imm2.doc/printable_doc.html).

- **VMware ESXi embedded hypervisor**

An optional USB flash device or SD card with VMware ESXi embedded hypervisor software is available for purchase. Hypervisor is virtualization software that enables multiple operating systems to run on a host system at the same time. The USB embedded hypervisor flash device can be installed in USB hypervisor connector on the system board. The SD card can be inserted into the SD adapter. For more information about using the embedded hypervisor, see “Using the embedded hypervisor” on page 55.

- **Remote presence capability and blue-screen capture**

The remote presence and blue-screen capture features are integrated functions of the IMM2. The remote presence feature provides the following functions:



- Remotely viewing video with graphics resolutions up to 1600 x 1200 at 75 Hz, regardless of the system state
- Remotely accessing the server, using the keyboard and mouse from a remote client
- Mapping the CD or DVD drive, diskette drive, SD card, and USB flash drive on a remote client, and mapping ISO and diskette image files as virtual drives that are available for use by the server
- Uploading a diskette image to the IMM memory and mapping it to the server as a virtual drive

The blue-screen capture feature captures the video display contents before the IMM restarts the server when the IMM detects an operating-system hang condition. A system administrator can use the blue-screen capture feature to assist in determining the cause of the hang condition. For more information, see “Using the remote presence and blue-screen capture features” on page 53.

- **Ethernet controller configuration**

For information about configuring the Ethernet controller, see “Configuring the Ethernet controller” on page 55.

- **Features on Demand software Ethernet software**

The server provides Features on Demand software Ethernet support. You can purchase a Features on Demand software upgrade key for Fibre Channel over Ethernet (FCoE) and iSCSI storage protocols. For more information, see “Enabling Features on Demand Ethernet software” on page 56.

- **Features on Demand software RAID software**

The server provides Features on Demand software RAID support. You can purchase a Features on Demand software upgrade key for RAID. For more information, see “Enabling Features on Demand RAID software” on page 56.

- **ToolsCenter Suit CLI (OneCLI) program**

The Lenovo ToolsCenter Suite CLI (OneCLI) program is a collection of server management tools that utilize a command line interface program to manage firmware, hardware, and operating systems. And it covers the configuration function, which is an alternative to the Setup Utility for modifying UEFI settings. For more information about using this program, see “Lenovo ToolsCenter Suite CLI program” on page 56.

- **Configuring RAID arrays**

For information about configuring RAID arrays, see “Configuring RAID arrays” on page 56.

## Using the ServerGuide Setup and Installation CD

Use this information as an overview for using the ServerGuide Setup and Installation CD.

The *ServerGuide Setup and Installation CD* provides software setup tools and installation tools that are designed for your server. The ServerGuide program detects the server model and optional hardware devices that are installed and uses that information during setup to configure the hardware. The ServerGuide simplifies the operating-system installations by providing updated device drivers and, in some cases, installing them automatically.

You can download a free image of the *ServerGuide Setup and Installation CD* from <http://www.ibm.com/support/entry/portal/docdisplay?Indocid=SERV-GUIDE>.

In addition to the *ServerGuide Setup and Installation CD*, you must have your operating-system CD to install the operating system.

### ServerGuide features

This information provides an overview of the ServerGuide features.

Features and functions can vary slightly with different versions of the ServerGuide program. To learn more about the version that you have, start the *ServerGuide Setup and Installation* CD and view the online overview. Not all features are supported on all server models.

The ServerGuide program performs the following features:

- An easy-to-use interface
- Diskette-free setup, and configuration programs that are based on detected hardware
- Device drivers that are provided for the server model and detected hardware
- Operating-system partition size and file-system type that are selectable during setup

The ServerGuide program performs the following tasks:

- Sets system date and time
- Detects installed hardware options and provides updated device drivers for most adapters and devices
- Provides diskette-free installation for supported Windows operating systems
- Includes an online readme file with links to tips for your hardware and operating-system installation

## Setup and configuration overview

ServerGuide setup and configuration overview

When you use the *ServerGuide Setup and Installation* CD, you do not need setup diskettes. You can use the CD to configure any supported server model. The setup program provides a list of tasks that are required to set up your server model. On a server with a ServeRAID adapter or SAS/SATA controller with RAID capabilities, you can run the SAS/SATA RAID configuration program to create logical drives.

**Note:** Features and functions can vary slightly with different versions of the ServerGuide program.

## Typical operating-system installation

ServerGuide typical operating-system installation

The ServerGuide program can reduce the time it takes to install an operating system. It provides the device drivers that are required for your hardware and for the operating system that you are installing. This section describes a typical ServerGuide operating-system installation.

**Note:** Features and functions can vary slightly with different versions of the ServerGuide program.

1. After you have completed the setup process, the operating-system installation program starts. (You will need your operating-system CD to complete the installation.)
2. The ServerGuide program stores information about the server model, service processor, hard disk drive controllers, and network adapters. Then, the program checks the CD for newer device drivers. This information is stored and then passed to the operating-system installation program.
3. The ServerGuide program presents operating-system partition options that are based on your operating-system selection and the installed hard disk drives.
4. The ServerGuide program prompts you to insert your operating-system CD and restart the server. At this point, the installation program for the operating system takes control to complete the installation.

## Installing your operating system without using ServerGuide

Use this information to install the operating system on the server without using ServerGuide.

If you have already configured the server hardware and you are not using the ServerGuide program to install your operating system, you can download operating-system installation instructions for the server from <http://www.lenovo.com/support>.

## Using the Setup Utility

Use these instructions to start the Setup Utility.

Use the Unified Extensible Firmware Interface (UEFI) Setup Utility program to perform the following tasks:

- View configuration information
- View and change assignments for devices and I/O ports
- Set the date and time
- Set and change passwords
- Set the startup characteristics of the server and the order of startup devices
- Set and change settings for advanced hardware features
- View, set, and change settings for power-management features
- View and clear error logs
- Change interrupt request (IRQ) settings
- Resolve configuration conflicts

### Starting the Setup Utility

Use this information to start up the Setup Utility.

To start the Setup Utility, complete the following steps:

Step 1. Turn on the server.

**Note:** Approximately 5 to 10 seconds after the server is connected to power, the power-control button becomes active.

Step 2. When the prompt <F1> Set up is displayed, press F1. If you have set an administrator password, you must type the administrator password to access the full Setup Utility menu. If you do not type the administrator password, a limited Setup Utility menu is available.

Step 3. Select settings to view or change.

### Setup Utility menu choices

Use the Setup Utility main menu to view and configure server configuration data and settings.

The following choices are on the Setup Utility main menu for the UEFI. Depending on the version of the firmware, some menu choices might differ slightly from these descriptions.

- **System Information**

Select this choice to view information about the server. When you make changes through other choices in the Setup Utility, some of those changes are reflected in the system information; you cannot change settings directly in the system information. This choice is on the full Setup Utility menu only.

- **System Summary**

Select this choice to view configuration information, including the ID, speed, and cache size of the microprocessors, machine type and model of the server, the serial number, the system UUID, and the amount of installed memory. When you make configuration changes through other options in the Setup Utility, the changes are reflected in the system summary; you cannot change settings directly in the system summary.

- **Product Data**

Select this choice to view the system-board identifier, the revision level or issue date of the firmware, the integrated management module and diagnostics code, and the version and date.

This choice is on the full Setup Utility menu only.

- **System Settings**

Select this choice to view or change the server component settings.

- **Adapters and UEFI Drivers**

Select this choice to view information about the UEFI 1.10 and UEFI 2.0 compliant adapters and drivers installed in the server.

- **Processors**

Select this choice to view or change the processor settings.

- **Memory**

Select this choice to view or change the memory settings.

- **Devices and I/O Ports**

Select this choice to view or change assignments for devices and input/output (I/O) ports. You can configure the serial ports, configure remote console redirection, enable or disable PCI slots and video controller. If you disable a device, it cannot be configured, and the operating system will not be able to detect it (this is equivalent to disconnecting the device).

- **Power**

Select this choice to view or change power capping to control consumption, processors, and performance states.

- **Operating Modes**

Select this choice to view or change the operating profile (performance and power utilization).

- **Legacy Support**

Select this choice to view or set legacy support.

**Note:** In the legacy mode, this system has limited ROM space for installed options. At most four network interface cards (NICs) are supported for legacy PXE boot. If more than four NICs are installed, legacy PXE boot will not be attempted on some of the NICs. To enable legacy PXE boot on the desired NIC connectors, prioritize the desired NIC connectors by changing the **ROM execution Order** or disable the NIC connectors that you do not use from the **Enable/Disable Adapter Option ROM Support** menu.

- **Force Legacy Video on Boot**

Select this choice to force INT video support, if the operating system does not support UEFI video output standards.

- **Rehook INT 19h**

Select this choice to enable or disable devices from taking control of the boot process. The default is **Disable**.

- **Legacy Thunk Support**

Select this choice to enable or disable UEFI to interact with PCI mass storage devices that are non-UEFI compliant. The default is **Enable**.

- **Infinite Boot Retry**

Select this choice to enable or disable UEFI to infinitely retry the legacy boot order. The default is **Disable**.

- **BBS Boot**

Select this choice to enable or disable legacy boot in BBS manner. The default is **Enable**.

- **System Security**

Select this choice to view or configure Trusted Platform Module (TPM) support.

- **Integrated Management Module**  
Select this choice to view or change the settings for the integrated management module.
- **Power Restore Policy**  
Select this choice to set the mode of operation after the power lost.
- **Commands on USB Interface**  
Select this choice to enable or disable the Ethernet over USB interface on IMM. The default is **Enable**.
- **Network Configuration**  
Select this choice to view the system management network interface port, the IMM MAC address, the current IMM IP address, and host name; define the static IMM IP address, subnet mask, and gateway address, specify whether to use the static IP address or have DHCP assign the IMM IP address, save the network changes, and reset the IMM.
- **Reset IMM to Defaults**  
Select this choice to view or reset IMM to the default settings.
- **Reset IMM**  
Select this choice to reset IMM.
- **Recovery**  
Select this choice to view or change the system recovery parameters.
  - **POST Attempts**  
Select this choice to view or change the number of attempts to POST.
    - **POST Attempts Limit**  
Select this choice to view or change the Nx boot failure parameters.
  - **System Recovery**  
Select this choice to view or change system recovery settings.
    - **POST Watchdog Timer**  
Select this choice to view or enable the POST watchdog timer.
    - **POST Watchdog Timer Value**  
Select this choice to view or set the POST loader watchdog timer value.
    - **Reboot System on NMI**  
Select this choice to enable or disable restarting the system whenever a nonmaskable interrupt (NMI) occurs. **Enable** is the default.
    - **Halt on Severe Error**  
Select this choice to enable or disable the system from booting into OS, displaying the POST event viewer whenever a severe error was detected. **Disable** is the default.
- **Storage**  
Select this choice to view or change the storage device settings.
- **Network**  
Select this choice to view or change the network device options, such as iSCSI.
- **Drive Health**  
Select this choice to view the status of the controllers installed in the blade server.
- **Date and Time**  
Select this choice to set the date and time in the server, in 24-hour format (*hour:minute:second*).

This choice is on the full Setup Utility menu only.

- **Start Options**

Select this choice to view or change the start options, including the startup sequence, keyboard NumLock state, PXE boot option, and PCI device boot priority. Changes in the startup options take effect when you start the server.

The startup sequence specifies the order in which the server checks devices to find a boot record. The server starts from the first boot record that it finds. If the server has Wake on LAN hardware and software and the operating system supports Wake on LAN functions, you can specify a startup sequence for the Wake on LAN functions. For example, you can define a startup sequence that checks for a disc in the CD-RW/DVD drive, then checks the hard disk drive, and then checks a network adapter.

This choice is on the full Setup Utility menu only.

- **Boot Manager**

Select this choice to view, add, delete, or change the device boot priority, boot from a file, select a one-time boot, or reset the boot order to the default setting.

- **System Event Logs**

Select this choice to enter the System Event Manager, where you can view the POST event log and the system-event log. You can use the arrow keys to move between pages in the error log. This choice is on the full Setup Utility menu only.

The POST event log contains the most recent error codes and messages that were generated during POST.

The system-event log contains POST and system management interrupt (SMI) events and all events that are generated by the baseboard management controller that is embedded in the integrated management module (IMM).

**Important:** If the system-error LED on the front of the server is lit but there are no other error indications, clear the system-event log. Also, after you complete a repair or correct an error, clear the system-event log to turn off the system-error LED on the front of the server.

- **POST Event Viewer**

- Select this choice to enter the POST event viewer to view the POST error messages.

- **System Event Log**

- Select this choice to view the system event log.

- **Clear System Event Log**

- Select this choice to clear the system event log.

- **User Security**

Select this choice to set, change, or clear passwords.

You can set, change, and delete a power-on password and an administrator password through this selection. If you set a power-on password, you must type the power-on password to complete the system startup and to have access to the Setup Utility menu.

A password must contain 6 to 20 characters. You can use any combination of alphabetic and numeric characters for passwords. Keep a record of your passwords in a secure place.

If you forget the power-on password, you can use the power-on password switch (switch 2) on the system board switch block (SW6) to regain access to the server. See Table 3 “System board SW6 switch block definition” on page 32.

**Attention:** If you set an administrator password and then forget it, there is no way to change, override, or remove it. You must replace the system board.

- **Save Settings**

Select this choice to save the changes that you have made in the settings.

- **Restore Settings**

Select this choice to cancel the changes that you have made in the settings and restore the previous settings.

- **Load Default Settings**

Select this choice to cancel the changes that you have made in the settings and restore the factory settings.

- **Exit Setup**

Select this choice to exit from the Setup Utility. If you have not saved the changes that you have made in the settings, you are asked whether you want to save the changes or exit without saving them.

## Using the Boot Manager

The Boot Manager program is a built-in, menu-driven configuration utility program that you can use to temporarily redefine the first startup device without changing settings in the Setup Utility.

To use the Boot Manager program, complete the following steps:

Step 1. Turn off the server.

Step 2. Restart the server.

Step 3. When the prompt <F12> Select Boot Device is displayed, press F12.

Step 4. Use the Up arrow and Down arrow keys to select an item from the menu and press Enter.

The next time the server starts, it returns to the startup sequence that is set in the Setup Utility.

## Starting the backup server firmware

The system board contains a backup copy area for the server firmware. This is a secondary copy of the server firmware that you update only during the process of updating the server firmware. If the primary copy of the server firmware becomes damaged, use this backup copy.

To force the server to start from the backup copy, turn off the server; then, place the UEFI boot backup jumper (J15) in the backup position (pins 2 and 3). See “System-board switches, jumpers, and buttons” on page 30 for the location of the UEFI boot backup jumper (J15).

Use the backup copy of the server firmware until the primary copy is restored. After the primary copy is restored, turn off the server; then, move the UEFI boot backup jumper (J15) back to the primary position (pins 1 and 2).

## The UpdateXpress System Pack Installer

The UpdateXpress System Pack Installer detects supported and installed device drivers and firmware in the server and installs available updates.

For additional information and to download the UpdateXpress System Pack Installer, go to the ToolsCenter for System x and BladeCenter at <http://publib.boulder.ibm.com/infocenter/toolsctr/v1r0/> and click **UpdateXpress System Pack Installer**.

## Using the integrated management module

The integrated management module (IMM) is a second generation of the functions that were formerly provided by the baseboard management controller hardware. It combines service processor functions, video controller, and remote presence function in a single chip.

The IMM supports the following basic systems-management features:

- Alerts (in-band and out-of-band alerting, PET traps - IPMI style, SNMP, e-mail).
- Auto Boot Failure Recovery (ABR).
- Automatic microprocessor disable on failure and restart in a two-microprocessor configuration when one microprocessor signals an internal error. When one of the microprocessors fail, the server will disable the failing microprocessor and restart with the other microprocessor.
- Automatic Server Restart (ASR) when POST is not complete or the operating system hangs and the operating system watchdog timer times-out. The IMM might be configured to watch for the operating system watchdog timer and reboot the system after a timeout, if the ASR feature is enabled. Otherwise, the IMM allows the administrator to generate a nonmaskable interrupt (NMI) by pressing an NMI button on the LCD system information display panel (if available) for an operating-system memory dump. ASR is supported by IPMI.
- A virtual media key, which enables remote presence support (remote video, remote keyboard/mouse, and remote storage).
- Boot sequence manipulation.
- Command-line interface.
- Configuration save and restore.
- DIMM error assistance. The Unified Extensible Firmware Interface (UEFI) disables a failing DIMM that is detected during POST, and the IMM lights the associated system error LED and the failing DIMM error LED.
- Environmental monitor with fan speed control for temperature, voltages, fan failure, power supply failure, and power backplane failure.
- Intelligent Platform Management Interface (IPMI) Specification V2.0 and Intelligent Platform Management Bus (IPMB) support.
- Invalid system configuration (CONFIG) LED support.
- LCD system information display panel (if available) reports errors that occur with fans, power supplies, microprocessor, hard disk drives, and system errors.
- Local firmware code flash update
- Nonmaskable interrupt (NMI) detection and reporting.
- Operating-system failure blue screen capture.
- PCI configuration data.
- Power/reset control (power-on, hard and soft shutdown, hard and soft reset, schedule power control).
- Query power-supply input power.
- ROM-based IMM firmware flash updates.
- Serial over LAN (SOL).
- Serial port redirection over telnet or ssh.
- SMI handling
- System event log (SEL) - user readable event log.

The IMM also provides the following remote server management capabilities through the ipmitool, a management utility program:

- **Command-line interface (IPMI Shell)**

The command-line interface provides direct access to server management functions through the IPMI 2.0 protocol. Use the command-line interface to issue commands to control the server power, view system



information, and identify the server. You can also save one or more commands as a text file and run the file as a script.

- **Serial over LAN**

Establish a Serial over LAN (SOL) connection to manage servers from a remote location. You can remotely view and change the UEFI settings, restart the server, identify the server, and perform other management functions. Any standard Telnet client application can access the SOL connection.

For more information about IMM, see the *Integrated Management Module II User's Guide* at [http://publib.boulder.ibm.com/infocenter/systemx/documentation/topic/com.lenovo.sysx.imm2.doc/printable\\_doc.html](http://publib.boulder.ibm.com/infocenter/systemx/documentation/topic/com.lenovo.sysx.imm2.doc/printable_doc.html).

## Using the remote presence and blue-screen capture features

The remote presence and blue-screen capture features are integrated functions of the IMM2.

The remote presence feature provides the following functions:

- Remotely viewing video with graphics resolutions up to 1600 x 1200 at 75 Hz, regardless of the system state
- Remotely accessing the server, using the keyboard and mouse from a remote client
- Mapping the CD or DVD drive, diskette drive, SD card, and USB flash drive on a remote client, and mapping ISO and diskette image files as virtual drives that are available for use by the server
- Uploading a diskette image to the IMM memory and mapping it to the server as a virtual drive

The blue-screen capture feature captures the video display contents before the IMM restarts the server when the IMM detects an operating-system hang condition. A system administrator can use the blue-screen capture to assist in determining the cause of the hang condition.

### Obtaining the IMM host name

Use this information to obtain the IMM host name.

If you are logging on to the IMM for the first time after installation, the IMM defaults to DHCP. If a DHCP server is not available, the IMM uses a static IP address of 192.168.70.125. The default IPv4 host name is "IMM-" (plus the last 12 characters on the IMM MAC address). The default host name also comes on the IMM network access tag that comes attached to the power supply on the rear of the server. The IMM network access tag provides the default host name of the IMM and does not require you to start the server.

The IPv6 link-local address (LLA) is derived from the IMM default host name. The IMM LLA is on the IMM network access tag is on the power supply on the rear of the server. To derive the link-local address, complete the following steps:

- Step 1. Take the last 12 characters on the IMM MAC address (for example, 5CF3FC5EAAD0).
- Step 2. Separate the number into pairs of hexadecimal characters (for example, 5C:F3:FC:5E:AA:D0).
- Step 3. Separate the first six and last six hexadecimal characters.
- Step 4. Add "FF" and "FE" in the middle of the 12 characters (for example, 5C F3 FC FF FE 5E AA D0).
- Step 5. Convert the first pair of hexadecimal characters to binary (for example, 5=0101, C=1100, which results in 01011100 F3 FC FF FE 5E AA D0).
- Step 6. Flip the 7th binary character from left (0 to 1 or 1 to 0), which results in 01011110 F3 FF FE 5E AA D0.
- Step 7. Convert the binary back to hexadecimal (for example, 5E F3FCFFFE5EAAD0).

## Obtaining the IP address for the IMM

Use this information to obtain the IP address for the IMM.

To access the web interface to use the remote presence feature, you need the IP address or host name of the IMM. You can obtain the IMM IP address through the Setup Utility and you can obtain the IMM host name from the IMM network access tag. The server comes with a default IP address for the IMM of 192.168.70.125.

To obtain the IP address, complete the following steps:

Step 1. Turn off the server.

**Note:** Approximately 5 to 10 seconds after the server is connected to power, the power-control button becomes active.

Step 2. When the prompt <F1> Set up is displayed, press F1. (This prompt is displayed on the screen for only a few seconds. You must press F1 quickly.) If you have set both a power-on password and an administrator password, you must type the administrator password to access the full Setup Utility menu.

Step 3. From the Setup Utility main menu, select **System Settings**.

Step 4. On the next screen, select **Integrated Management Module**.

Step 5. On the next screen, select **Network Configuration**.

Step 6. Find the IP address and write it down.

Step 7. Exit from the Setup Utility.

## Logging in to the Web interface

To log in to the IMM2 Web interface, do the following:

Step 1. On a system that is connected to the server, open a Web browser. In the **Address** or **URL** field, type the IP address or host name of the IMM2 to which you want to connect.

**Note:** If you are logging on to the IMM2 for the first time after installation, the IMM2 defaults to DHCP. If a DHCP host is not available, the IMM2 assigns a static IP address of 192.168.70.125. The IMM2 network access tag provides the default host name of the IMM2 and does not require you to start the server.

Step 2. On the Login page, type the user name and password. If you are using the IMM2 for the first time, you can obtain the user name and password from your system administrator. All login attempts are documented in the system-event log.

**Note:** The IMM2 is set initially with a user name of USERID and password of PASSWORD (with a zero, not the letter O). You have read and write access. You must change the default password the first time you log in.

Step 3. Click **Log in** to start the session. The System Status and Health page provides a quick view of the system status.

**Note:** If you boot to the operating system while in the IMM2 GUI and the message “Booting OS or in unsupported OS” is displayed under **System Status** → **System State**, disable Windows 2008 or 2012 firewall or type the following command in the Windows 2008 or 2012 console. This might also affect blue-screen capture features.

```
netsh advfirewall firewall set icmpsetting type=8 mode=ENABLE
```

By default, the icmp packet is blocked by Windows firewall. The IMM2 GUI will then change to the “OS booted” status after you change the setting as indicated above in both the Web and CLI interfaces.

## Using the embedded hypervisor

The VMware ESXi embedded hypervisor software is available on the optional USB flash device or SD card with embedded hypervisor.

The USB flash device can be installed in the USB hypervisor connector on the system board (see “System-board internal connectors” on page 28 for the location of the connectors). The SD card can be inserted into the SD adapter. Hypervisor is virtualization software that enables multiple operating systems to run on a host system at the same time. The USB flash device or SD card is required to activate the hypervisor functions.

To start using the embedded hypervisor functions, you must add the USB flash device or SD card to the startup sequence in the Setup Utility.

To add the USB flash device or SD card to the startup sequence, complete the following steps:

Step 1. Turn on the server.

**Note:** Approximately 5 to 10 seconds after the server is connected to power, the power-control button becomes active.

Step 2. When the prompt <F1> Set up is displayed, press F1.

Step 3. From the Setup Utility main menu, select **Boot Manager**.

Step 4. Select **Add Boot Option**; then, select **Generic Boot Option → Embedded Hypervisor**. Press Enter, and then select Esc.

Step 5. Select **Change Boot Order → Change the order**. Use the Up arrow and Down Arrow keys to select **Embedded Hypervisor** and use the plus (+) and minus (-) keys to move Embedded Hypervisor in the boot order. When **Embedded Hypervisor** is in the correct location in the boot order, press Enter. Select **Commit Changes** and press Enter.

Step 6. Select **Save Settings** and then select **Exit Setup**.

If the embedded hypervisor flash device image becomes corrupt, go to <https://my.vmware.com/web/vmware/downloads> and follow the instructions on the screen.

For additional information and instructions, see VMware vSphere 4.1 Documentation at [http://www.vmware.com/support/pubs/vs\\_pages/vsp\\_pubs\\_esxi41\\_e\\_vc41.html](http://www.vmware.com/support/pubs/vs_pages/vsp_pubs_esxi41_e_vc41.html) or the *VMware vSphere Installation and Setup Guide* at <http://pubs.vmware.com/vsphere-50/topic/com.vmware.ICbase/PDF/vsphere-esxi-vcenter-server-50-installation-setup-guide.pdf>.

## Configuring the Ethernet controller

Use this information to configure the Ethernet controller.

The Ethernet controllers are integrated on the system board. They provide an interface for connecting to a 10 Mbps, 100 Mbps, or 1 Gbps network and provide full-duplex (FDX) capability, which enables simultaneous transmission and reception of data on the network. If the Ethernet ports in the server support auto-negotiation, the controllers detect the data-transfer rate (10BASE-T, 100BASE-TX, or 1000BASE-T) and duplex mode (full-duplex or half-duplex) of the network and automatically operate at that rate and mode.

You do not have to set any jumpers or configure the controllers. However, you must install a device driver to enable the operating system to address the controllers.

To find device drivers and information about configuring the Ethernet controllers, go to <http://www.lenovo.com/support>.

## Enabling Features on Demand Ethernet software

You can activate the Features on Demand (FoD) software upgrade key for Fibre Channel over Ethernet (FCoE) and iSCSI storage protocols that is integrated in the integrated management module.

For more information and instructions for activating the Features on Demand Ethernet software key, see the *Features on Demand User's Guide*. To download the document, go to <http://www.ibm.com/systems/x/fod/>, log in, and click **Help**.

## Enabling Features on Demand RAID software

You can activate the Features on Demand (FoD) software upgrade key for RAID that is integrated in the integrated management module.

For more information and instructions for activating the Features on Demand RAID software key, see the *Features on Demand User's Guide*. To download the document, go to <http://www.ibm.com/systems/x/fod/>, log in, and click **Help**.

## Configuring RAID arrays

Through the Setup Utility, you can access utilities to configure RAID arrays.

The specific procedure for configuring arrays depends on the RAID controller that you are using. For details, see the documentation for your RAID controller. To access the utility for your RAID controller, complete the following steps:

Step 1. Turn on the server.

**Note:** Approximately 10 seconds after the server is connected to power, the power-control button becomes active.

Step 2. When prompted, <F1 Setup> is displayed, press F1. If you have set an administrator password, you must type the administrator password to access the full Setup Utility menu. If you do not type the administrator password, a limited Setup Utility menu is available.

Step 3. Select **System Settings → Storage**.

Step 4. Press Enter to refresh the list of device drivers.

Step 5. Select the device driver for your RAID controller and press Enter.

Step 6. Follow the instructions in the documentation for your RAID controller.

## Lenovo ToolsCenter Suite CLI program

The Lenovo ToolsCenter Suite CLI program is a collection of server management tools. Lenovo ToolsCenter Suite CLI also covers the configuration function, which is an alternative to the Setup Utility for modifying UEFI settings.

Lenovo ToolsCenter Suite CLI has the following features:

- Utilizing a command line interface to manage firmware, hardware, and operating systems
- Modifying UEFI settings from the command line without restarting the system to access the Setup Utility
- Configuring the optional remote presence features or other IMM2 settings
- Providing IMM2 LAN over USB interface configuration and issuing setup commands through the command-line interface

- Scripting environments through a batch-processing mode
- Saving any of the settings as a file and running the file as a script

For more information and to download the program, go to <https://support.lenovo.com/us/en/documents/LNVO-CENTER>.

## Using Lenovo XClarity Administrator

The initial setup of Lenovo XClarity Administrator includes the following:

- Preparing the network
- Installing and configuring the Lenovo XClarity Administrator virtual appliance
- Managing systems
- Setting up automatic problem notification optionally

To manage systems based on the network topology that is implemented in your environment, there are a number of different ways to connect manageable systems to the network and to set up the Lenovo XClarity Administrator. If you plan to use Lenovo XClarity Administrator to manage the server, you must check for the latest applicable Lenovo XClarity Administrator updates. For installing the Lenovo XClarity Administrator in VMware ESXi-based and Hyper-V environments and downloading Lenovo XClarity Administrator updates, go to:

<https://support.lenovo.com/us/en/documents/LNVO-XCLARIT>

Lenovo XClarity Administrator offers a free, 90-day trial license that enables you to use all available features (including operating-system deployment, firmware maintenance, and configuration management) for a limited time. To continue using Lenovo XClarity Administrator after the 90-day trial period, you are required to purchase a full-function-enablement license for each Lenovo XClarity Administrator instance. You can purchase and download the license from:

<https://support.lenovo.com/us/en/documents/lnvo-lxcaupd>

## Updating the Universal Unique Identifier (UUID)

The Universal Unique Identifier (UUID) must be updated when the system board is replaced. Use the Lenovo ToolsCenter Suite CLI (OneCLI) to update the UUID in the UEFI-based server.

OneCLI is an online tool that supports several operating systems. Make sure that you download the version for your operating system. You can download OneCLI from the Lenovo Web site. To download OneCLI and update the UUID, do the following:

**Note:** Changes are made periodically to the Lenovo Web site. The actual procedure might vary slightly from what is described in this document.

Step 1. Download OneCLI:

- a. Go to <http://www.lenovo.com/support>.
- b. Click the **Downloads** tab at the top of the panel.
- c. Under **ToolsCenter**, select **View ToolsCenter downloads**.
- d. Select **Lenovo ToolsCenter Suite CLI**.
- e. Scroll down, click the link, and download the OneCLI version for your operating system.

Step 2. OneCLI sets the UUID in the IMM2. Select one of the following methods to access the IMM2 to set the UUID:

- Online from the target system, such as LAN or keyboard console style (KCS) access
- Remote access to the target system (LAN based)

- Bootable medium containing OneCLI (LAN or KCS, depending upon the bootable media)

Step 3. Copy and unpack the OneCLI package, which also includes other required files, to the server. Make sure that you unpack the OneCLI and the required files to the same directory.

Step 4. After you install OneCLI, use the following command syntax to set the UUID:

```
onecli config set SYSTEM_PROD_DATA.SysInfoUUID <uuid_value> [access_method]
```

Where:

*<uuid\_value>*

Up to 16-byte hexadecimal value assigned by you.

*[access\_method]*

The access method that you selected to use from the following methods:

- Online authenticated LAN access, type the command:

```
[--imm imm_user_id:imm_password@imm_internal_ip]
```

Where:

*imm\_internal\_ip*

The IMM2 internal LAN/USB IP address. The default value is 169.254.95.118.

*imm\_user\_id*

The IMM2 account (1 of 12 accounts). The default value is USERID.

*imm\_password*

The IMM2 account password (1 of 12 accounts). The default value is PASSWORD (with a zero 0 not an O).

**Note:** If you do not specify any of these parameters, OneCLI will use the default values. When the default values are used and OneCLI is unable to access the IMM2 using the online authenticated LAN access method, OneCLI will automatically use the unauthenticated KCS access method.

Example that does not use the user ID and password default values:

```
onecli config set SYSTEM_PROD_DATA.SysInfoUUID <uuid_value> --user <user_id>
--password <password>
```

Example that uses the user ID and password default values:

```
onecli config set SYSTEM_PROD_DATA.SysInfoUUID <uuid_value>
```

- Online KCS access (unauthenticated and user restricted):

You do not need to specify a value for *access\_method* when you use this access method.

Example:

```
onecli config set SYSTEM_PROD_DATA.SysInfoUUID <uuid_value>
```

The KCS access method uses the IPMI/KCS interface. This method requires that the IPMI driver be installed. Some operating systems have the IPMI driver installed by default. OneCLI provides the corresponding mapping layer. For more details, see the *Lenovo ToolsCenter Suite CLI Users Guide*. To access this guide, do the following:

1. Go to <http://www.lenovo.com/support>.
2. Click the **Downloads** tab at the top of the panel.
3. Under **ToolsCenter**, select **View ToolsCenter downloads**.
4. Select **Lenovo ToolsCenter Suite CLI**.

5. Scroll down and click the link and download the OneCLI version for your operating system. Scroll down and look under **Online Help** to download the *Lenovo ToolsCenter Suite CLI Users Guide*.

- Remote LAN access, type the command:

**Note:** When using the remote LAN access method to access IMM2 using the LAN from a client, the *host* and the *imm\_external\_ip* address are required parameters.

```
[--imm imm_user_id:imm_password@imm_external_ip]
```

Where:

*imm\_external\_ip*

The external IMM2 LAN IP address. There is no default value. This parameter is required.

*imm\_user\_id*

The IMM2 account (1 of 12 accounts). The default value is USERID.

*imm\_password*

The IMM2 account password (1 of 12 accounts). The default value is PASSWORD (with a zero 0 not an O).

Example that does not use the user ID and password default values:

```
onecli config set SYSTEM_PROD_DATA.SysInfoUUID <uuid_value> [--imm imm_user_id:imm_password@imm_internal_ip]
```

Example that does use the user ID and password default values:

```
onecli config set SYSTEM_PROD_DATA.SysInfoUUID <uuid_value>
```

- Bootable media:

You can also build a bootable medium using the applications available through the ToolsCenter Web site at <https://support.lenovo.com/us/en/documents/LNVO-CENTER>. From the **ToolsCenter** page, scroll down for the available tools.

Step 5. Restart the server.

## Updating the DMI/SMBIOS data

The Desktop Management Interface (DMI) must be updated when the system board is replaced. Use the Lenovo ToolsCenter Suite CLI (OneCLI) to update the DMI in the UEFI-based server. OneCLI is an online tool that supports several operating systems. Make sure that you download the version for your operating system. You can download OneCLI from the Lenovo Web site. To download OneCLI and update the DMI, do the following:

**Note:** Changes are made periodically to the Lenovo Web site. The actual procedure might vary slightly from what is described in this document.

Step 1. Go to <https://support.lenovo.com/us/en/documents/LNVO-TCLI>. Then, find and download the OneCLI version for your operating system.

Step 2. OneCLI sets the DMI in the IMM2. Select one of the following methods to access the IMM2 to set the DMI:

- Online from the target system, such as LAN or keyboard console style (KCS) access
- Remote access to the target system (LAN based)
- Bootable medium containing ASU (LAN or KCS, depending upon the bootable media)

Step 3. Copy and unpack the OneCLI package, which also includes other required files, to the server. Make sure that you unpack the OneCLI and the required files to the same directory. In addition to the application executable (OneCLI or OneCLI64), the following files are required:

- For Windows based operating systems:

- *ibm\_rndis\_server\_os.inf*
- *device.cat*
- For Linux based operating systems:
  - *cdc\_interface.sh*

Step 4. After you install OneCLI, type the following commands to set the DMI:

```
onecli config set SYSTEM_PROD_DATA.SysInfoProdName <m/t_model> [access_method]
onecli config set SYSTEM_PROD_DATA.SysInfoSerialNum <s/n> [access_method]
onecli config set SYSTEM_PROD_DATA.SysEncloseAssetTag <asset_tag> [access_method]
```

Where:

*<m/t\_model>*

The server machine type and model number. Type *m t m xxxxyyy*, where *xxxx* is the machine type and *yyy* is the server model number.

*<s/n>*

The serial number on the server. Type *sn zzzzzzz*, where *zzzzzz* is the serial number.

*<asset\_method>*

The server asset tag number. Type *asset aaaaaaaaaaaaaaaaaaaaaaaaaaaaaa*, where *aaaaaaaaaaaaaaaaaaaaaaaaaaaaa* is the asset tag number.

*[access\_method]*

The access method that you select to use from the following methods:

- Online authenticated LAN access, type the command: `[--imm imm_user_id:imm_password@imm_internal_ip]`

Where:

*imm\_internal\_ip*

The IMM2 internal LAN/USB IP address. The default value is 169.254.95.118.

*imm\_user\_id*

The IMM2 account (1 of 12 accounts). The default value is USERID.

*imm\_password*

The IMM2 account password (1 of 12 accounts). The default value is PASSWORD (with a zero 0 not an O).

**Note:** If you do not specify any of these parameters, OneCLI will use the default values. When the default values are used and OneCLI is unable to access the IMM2 using the online authenticated LAN access method, OneCLI will automatically use the unauthenticated KCS access method.

Examples that do use the user ID and password default values:

```
onecli config set SYSTEM_PROD_DATA.SysInfoProdName <m/t_model>
onecli config set SYSTEM_PROD_DATA.SysInfoSerialNum <s/n>
onecli config set SYSTEM_PROD_DATA.SysEncloseAssetTag <asset_tag>
```

- Online KCS access (unauthenticated and user restricted): You do not need to specify a value for *access\_method* when you use this access method.

The KCS access method uses the IPMI/KCS interface. This method requires that the IPMI driver be installed. Some operating systems have the IPMI driver installed by default. OneCLI provides the corresponding mapping layer. To download the *Lenovo ToolsCenter Suite CLI Users Guide*, do the following:

1. Go to <http://www.lenovo.com/support>.



2. Click **Downloads** tab at the top of the panel.
3. Under **ToolsCenter**, select **View ToolsCenter downloads**.
4. Select **Lenovo ToolsCenter Suite CLI**.
5. Scroll down and click the link and download the OneCLI version for your operating system. Scroll down and look under **Online Help** to download the *Lenovo ToolsCenter Suite CLI Users Guide*.

The following commands are examples of not using the user ID and password default values:

```
onecli config set SYSTEM_PROD_DATA.SysInfoProdName <m/t_model>
onecli config set SYSTEM_PROD_DATA.SysInfoSerialNum <s/n>
onecli config set SYSTEM_PROD_DATA.SysEncloseAssetTag <asset_tag>
```

- Remote LAN access, type the command:

**Note:** When using the remote LAN access method to access IMM2 using the LAN from a client, the *host* and the *imm\_external\_ip* address are required parameters.

```
[--imm imm_user_id:imm_password@imm_external_ip]
```

Where:

*imm\_external\_ip*

The external IMM2 LAN IP address. There is no default value. This parameter is required.

*imm\_user\_id*

The IMM2 account (1 of 12 accounts). The default value is USERID.

*imm\_password*

The IMM2 account password (1 of 12 accounts). The default value is PASSWORD (with a zero 0 not an O).

Examples that do use the user ID and password default values:

```
onecli config set SYSTEM_PROD_DATA.SysInfoProdName <m/t_model> --host <imm_ip>
onecli config set SYSTEM_PROD_DATA.SysInfoSerialNum <s/n> --host <imm_ip>
onecli config set SYSTEM_PROD_DATA.SysEncloseAssetTag <asset_tag> --host <imm_ip>
```

- Bootable media:

You can also build a bootable medium using the applications available through the ToolsCenter Web site at <https://support.lenovo.com/us/en/documents/LNVO-CENTER>. From the **ToolsCenter** page, scroll down for the available tools.

Step 5. Restart the server.



---

## Chapter 3. Troubleshooting

This chapter describes the diagnostic tools and troubleshooting information that are available to help you solve problems that might occur in the server.

If you cannot diagnose and correct a problem by using the information in this chapter, see Appendix D “Getting help and technical assistance” on page 1149 for more information.

---

### Start here

You can solve many problems without outside assistance by following the troubleshooting procedures in this documentation and on the World Wide Web.

This document describes the diagnostic tests that you can perform, troubleshooting procedures, and explanations of error messages and error codes. The documentation that comes with your operating system and software also contains troubleshooting information.

### Diagnosing a problem

Before you call an approved warranty service provider, follow these procedures in the order in which they are presented to diagnose a problem with your server.

Step 1. **Return the server to the condition it was in before the problem occurred.** If any hardware, software, or firmware was changed before the problem occurred, if possible, reverse those changes. This might include any of the following items:

- Hardware components
- Device drivers and firmware
- System software
- UEFI firmware
- System input power or network connections

Step 2. **View the light path diagnostics LEDs and event logs.** The server is designed for ease of diagnosis of hardware and software problems.

- **Event logs:** See “Event logs” on page 73 for information about notification events and diagnosis.
- **Software or operating-system error codes:** See the documentation for the software or operating system for information about a specific error code. See the manufacturer's website for documentation.

Step 3. **Run Dynamic System Analysis (DSA) and collect system data.**

Run Dynamic System Analysis (DSA) to collect information about the hardware, firmware, software, and operating system. Have this information available when you contact your approved warranty service provider. For instructions for running DSA, see the *Dynamic System Analysis Installation and User's Guide*.

To download the latest version of DSA code and the *Dynamic System Analysis Installation and User's Guide*, go to <https://support.lenovo.com/us/en/documents/LNVO-DSA>.

Step 4. **Check for and apply code updates.**

Fixes or workarounds for many problems might be available in updated UEFI firmware, device firmware, or device drivers. To display a list of available updates for the server, go to <http://www.ibm.com/support/fixcentral>.

**Attention:** Installing the wrong firmware or device-driver update might cause the server to malfunction. Before you install a firmware or device-driver update, read any readme and change history files that are provided with the downloaded update. These files contain important information about the update and the procedure for installing the update, including any special procedure for updating from an early firmware or device-driver version to the latest version.

**Important:** Some cluster solutions require specific code levels or coordinated code updates. If the device is part of a cluster solution, verify that the latest level of code is supported for the cluster solution before you update the code.

a. **Install UpdateXpress system updates.**

You can install code updates that are packaged as an UpdateXpress System Pack or UpdateXpress CD image. An UpdateXpress System Pack contains an integration-tested bundle of online firmware and device-driver updates for your server. In addition, you can use the ToolsCenter Bootable Media Creator to create bootable media that is suitable for applying firmware updates and running preboot diagnostics. For more information about UpdateXpress System Packs, see <http://www.ibm.com/support/entry/portal/docdisplay?Indocid=SERV-XPRESS> and “Updating the firmware” on page 43. For more information about the Bootable Media Creator, see <https://support.lenovo.com/us/en/documents/LNVO-BOMC>.

Be sure to separately install any listed critical updates that have release dates that are later than the release date of the UpdateXpress System Pack or UpdateXpress image (see step b).

b. **Install manual system updates.**

1. **Determine the existing code levels.**

In DSA, click **Firmware/VPD** to view system firmware levels, or click **Software** to view operating-system levels.

2. **Download and install updates of code that is not at the latest level.**

To display a list of available updates for the server, go to <http://www.ibm.com/support/fixcentral>.

When you click an update, an information page is displayed, including a list of the problems that the update fixes. Review this list for your specific problem; however, even if your problem is not listed, installing the update might solve the problem.

Step 5. **Check for and correct an incorrect configuration.**

If the server is incorrectly configured, a system function can fail to work when you enable it; if you make an incorrect change to the server configuration, a system function that has been enabled can stop working.

a. **Make sure that all installed hardware and software are supported.**

See <http://www.lenovo.com/serverproven/> to verify that the server supports the installed operating system, optional devices, and software levels. If any hardware or software component is not supported, uninstall it to determine whether it is causing the problem. You must remove nonsupported hardware before you contact an approved warranty service provider for support.

b. **Make sure that the server, operating system, and software are installed and configured correctly.**

Many configuration problems are caused by loose power or signal cables or incorrectly seated adapters. You might be able to solve the problem by turning off the server, reconnecting cables, reseating adapters, and turning the server back on. For information about performing the checkout procedure, see “About the checkout procedure” on page 66. For information about configuring the server, see Chapter 2 “Configuration information and instructions” on page 43.

**Step 6. See controller and management software documentation.**

If the problem is associated with a specific function (for example, if a RAID hard disk drive is marked offline in the RAID array), see the documentation for the associated controller and management or controlling software to verify that the controller is correctly configured.

Problem determination information is available for many devices such as RAID and network adapters.

For problems with operating systems, software, or devices, go to <http://www.lenovo.com/support>.

**Step 7. Check for troubleshooting procedures and RETAIN tips.**

Troubleshooting procedures and RETAIN tips document known problems and suggested solutions. To search for troubleshooting procedures and RETAIN tips, go to <http://www.lenovo.com/support>.

**Step 8. Use the troubleshooting tables.**

See “Troubleshooting by symptom” on page 78 to find a solution to a problem that has identifiable symptoms.

A single problem might cause multiple symptoms. Follow the troubleshooting procedure for the most obvious symptom. If that procedure does not diagnose the problem, use the procedure for another symptom, if possible.

If the problem remains, contact an approved warranty service provider for assistance with additional problem determination and possible hardware replacement. To open an online service request, go to [http://www.ibm.com/support/entry/portal/Open\\_service\\_request](http://www.ibm.com/support/entry/portal/Open_service_request). Be prepared to provide information about any error codes and collected data.

## Undocumented problems

If you have completed the diagnostic procedure and the problem remains, the problem might not have been previously identified. After you have verified that all code is at the latest level, all hardware and software configurations are valid, and no light path diagnostics LEDs or log entries indicate a hardware component failure, contact an approved warranty service provider for assistance.

To open an online service request, go to [http://www.ibm.com/support/entry/portal/Open\\_service\\_request](http://www.ibm.com/support/entry/portal/Open_service_request). Be prepared to provide information about any error codes and collected data and the problem determination procedures that you have used.

---

## Service bulletins

Lenovo continually updates the support website with the latest tips and techniques that you can use to solve problem that you might have with the Lenovo Storage DX8200 server.

To find service bulletins that are available for the Lenovo Storage DX8200 server, go to <http://www.lenovo.com/support> and search for 5120, 5128, 5133, 5135, 5136, and 5139, and retain.

---

## Checkout procedure

The checkout procedure is the sequence of tasks that you should follow to diagnose a problem in the server.

### About the checkout procedure

Before you perform the checkout procedure for diagnosing hardware problems, review the following information.

- Read the safety information that begins on page “Safety” on page v.
- Dynamic System Analysis (DSA) provides the primary methods of testing the major components of the server, such as the system board, Ethernet controller, keyboard, mouse (pointing device), serial ports, and hard disk drives. You can also use them to test some external devices. If you are not sure whether a problem is caused by the hardware or by the software, you can use the diagnostic programs to confirm that the hardware is working correctly.
- When you run DSA, a single problem might cause more than one error message. When this happens, correct the cause of the first error message. The other error messages usually will not occur the next time you run DSA.

**Important:** If multiple error codes or LCD system information display panel (if available) indicate a microprocessor error, the error might be in the microprocessor or in the microprocessor socket. See “Microprocessor problems” on page 86 for information about diagnosing microprocessor problems.

- Before you run DSA, you must determine whether the failing server is part of a shared hard disk drive cluster (two or more servers sharing external storage devices). If it is part of a cluster, you can run all diagnostic programs except the ones that test the storage unit (that is, a hard disk drive in the storage unit) or the storage adapter that is attached to the storage unit. The failing server might be part of a cluster if any of the following conditions is true:
  - You have identified the failing server as part of a cluster (two or more servers sharing external storage devices).
  - One or more external storage units are attached to the failing server and at least one of the attached storage units is also attached to another server or unidentifiable device.
  - One or more servers are located near the failing server.

**Important:** If the server is part of a shared hard disk drive cluster, run one test at a time. Do not run any suite of tests, such as “quick” or “normal” tests, because this might enable the hard disk drive diagnostic tests.

- If the server is halted and a POST error code is displayed, see Appendix B “UEFI/POST diagnostic codes” on page 991. If the server is halted and no error message is displayed, see “Troubleshooting by symptom” on page 78 and “Solving undetermined problems” on page 105.
- For information about power-supply problems, see “Solving power problems” on page 102, “Power problems” on page 90, and “Power-supply LEDs” on page 69.
- For intermittent problems, check the event log; see “Event logs” on page 73 and Appendix C “DSA diagnostic test results” on page 1013.

### Performing the checkout procedure

Use this information to perform the checkout procedure.

To perform the checkout procedure, complete the following steps:

Step 1. Is the server part of a cluster?

- **No:** Go to Step 2 on page 67.
- **Yes:** Shut down all failing servers that are related to the cluster. Go to Step 2 on page 67.

Step 2. Complete the following steps:

- Check the power supply LEDs (see “Power-supply LEDs” on page 69).
- Turn off the server and all external devices.
- Check all internal and external devices for compatibility at <http://www.lenovo.com/serverproven/>.
- Check all cables and power cords.
- Set all display controls to the middle positions.
- Turn on all external devices.
- Turn on the server. If the server does not start, see “Troubleshooting by symptom” on page 78.
- Check the system-error LED on the operator information panel. If it is lit, check the LCD system information display panel (if available, see “LCD system information display panel” on page 21).
- Check for the following results:
  - Successful completion of POST (see “POST” on page 75 for more information)
  - Successful completion of startup, which is indicated by a readable display of the operating-system desktop

Step 3. Is there a readable image on the monitor screen?

- **No:** Find the failure symptom in “Troubleshooting by symptom” on page 78; if necessary, see “Solving undetermined problems” on page 105.
- **Yes:** Run DSA (see “Running the DSA Preboot diagnostic programs” on page 76).
  - If DSA reports an error, follow the instructions in Appendix C “DSA diagnostic test results” on page 1013.
  - If DSA does not report an error but you still suspect a problem, see “Solving undetermined problems” on page 105.

---

## Diagnostic tools

The section introduces available tools to help you diagnose and solve hardware-related problems.

- **LCD system information display panel (available on some models)**

Use LCD system information display panel to diagnose system errors quickly.

- **Event logs**

The event logs list the error codes and messages that are generated when an error is detected for the subsystems IMM2, POST, DSA, and the server baseboard management controller. See “Event logs” on page 73 for more information.

- **Integrated management module II (IMM2)**

The IMM2 combines service processor functions, video controller, and remote presence and blue-screen capture features in a single chip. The IMM provides advanced service-processor control, monitoring, and alerting function. If an environmental condition exceeds a threshold or if a system component fails, the IMM lights LEDs to help you diagnose the problem, records the error in the IMM event log, and alerts you to the problem. Optionally, the IMM also provides a virtual presence capability for remote server management capabilities. The IMM provides remote server management through the following industry-standard interfaces:

- Intelligent Platform Management Protocol (IPMI) version 2.0
- Simple Network Management Protocol (SNMP) version 3.0; SNMP Trap version 1.0
- Common Information Model (CIM)
- Web browser

For more information about the IMM2, see “Using the integrated management module” on page 51, Appendix A “Integrated management module II (IMM2) error messages” on page 313, and the *Integrated Management Module II User's Guide* at [http://publib.boulder.ibm.com/infocenter/systemx/documentation/topic/com.lenovo.sysx.imm2.doc/printable\\_doc.html](http://publib.boulder.ibm.com/infocenter/systemx/documentation/topic/com.lenovo.sysx.imm2.doc/printable_doc.html).

- **Dynamic System Analysis**

DSA Preboot diagnostic program is stored in the integrated USB memory on the server. DSA Preboot collects and analyzes system information to aid in diagnosing server problems, as well as offering a rich set of diagnostic tests of the major components of the server. DSA Preboot collects the following information about the server:

- Drive health information
- IMM2 configuration information
- IMM2 environmental information
- Event logs for ServeRAID controllers and service processors
- Installed hardware, including PCI and USB information
- LCD system information display panel (if available) status
- Microprocessor, input/output hub, and UEFI error logs
- Network interfaces and settings
- Option card driver and firmware information
- RAID controller configuration
- Service processor (integrated management module) status and configuration
- System configuration
- Vital product data, firmware, and UEFI configuration

DSA Preboot also provides diagnostics for the following system components (when they are installed):

1. Emulex network adapter
2. IMM I2C bus
3. LCD system information display panel (available on some models)
4. Memory modules
5. Microprocessors
6. Optical devices (CD or DVD)
7. SAS or SATA drives
8. LSI Controller
9. Broadcom network adapter
10. FusionIO storage
11. Intel GPU
12. Nvidia GPU

See “Running the DSA Preboot diagnostic programs” on page 76 for more information on running the DSA Preboot program on the server.

- **Troubleshooting by symptom**



These tables list problem symptoms and actions to correct the problems. See “Troubleshooting by symptom” on page 78 for more information.

## Power-supply LEDs

The following minimum configuration is required for the server to start.

- One microprocessor in microprocessor socket 1
- One 4 GB DIMM on the system board
- One power supply
- Power cord
- Four cooling fans (fan 1, 2, 3, and 5)

## AC power-supply LEDs

The following minimum configuration is required for the DC LED on the power supply to be lit:

- Power supply
- Power cord

**Note:** You must turn on the server for the DC LED on the power supply to be lit.

The following illustration shows the locations of the power-supply LEDs on the ac power supply.

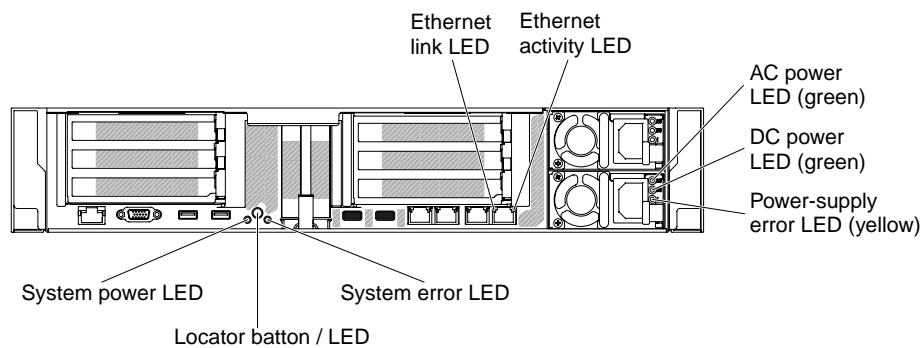

Figure 44. AC power-supply LEDs

The following table describes the problems that are indicated by various combinations of the power-supply LEDs on an ac power supply and suggested actions to correct the detected problems.

AC power-supply LEDs			Description	Action	Notes
AC	DC	Error (!)			
On	On/ Blinking	Off	Normal operation.		When the DC LED is blinking as a 1Hz rate, the PSU is at STANDBY mode, i.e. no DC power output from this PSU
Off	Off	Off	No ac power to the server or a problem with the ac power source.	<ol style="list-style-type: none"> <li>1. Check the ac power to the server.</li> <li>2. Make sure that the power cord is connected to a functioning power source.</li> <li>3. Restart the server. If the error remains, check the power-supply LEDs.</li> <li>4. If the problem remains, replace the power-supply.</li> </ol>	This is a normal condition when no ac power is present.
Off	Off	On	The power supply has failed.	Replace the power supply.	
Off	On/ Blinking	Off	The power supply has failed.	Replace the power supply.	
Off	On/ Blinking	On	The power supply has failed.	Replace the power supply.	
On	Off	Off	Power-supply not fully seated, faulty system board, or the power supply has failed.	<ol style="list-style-type: none"> <li>1. Reseat the power supply.</li> <li>2. Use the Power Configurator utility to ensure current system power consumption is under limitation. For more information and to download the utility, go to <a href="http://www.ibm.com/systems/bladecenter/resources/powerconfig.html">http://www.ibm.com/systems/bladecenter/resources/powerconfig.html</a>.</li> <li>3. Check the error LEDs on the system board and the IMM2 error messages. Follow steps in "Power problems" on page 90 and "Solving power problems" on page 102 until the problem is solved.</li> </ol>	Typically indicates a power-supply is not fully seated.
On	Off	On	The power supply has failed.	Replace the power supply.	
On	On/ Blinking	On	The power supply has failed.	Replace the power supply.	

## DC power-supply LEDs

Use this information to view DC power-supply LEDs.

The following illustration shows the locations of the power-supply LEDs on the dc power supply.

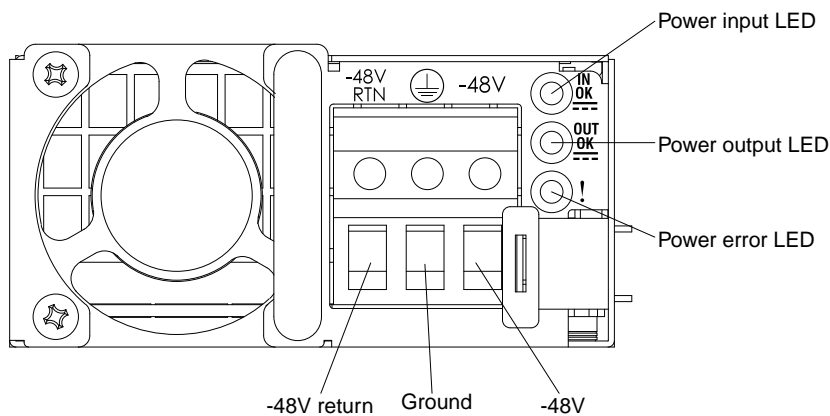

Figure 45. DC power-supply LEDs

The following table describes the problems that are indicated by various combinations of the power-supply LEDs on a dc power supply and suggested actions to correct the detected problems.

DC power-supply LEDs			Description	Action	Notes
IN	OUT	Error (!)			
On	On/ Blinking	Off	Normal operation.		When the OUT LED is blinking as a 1Hz rate, the PSU is at STANDBY mode, i.e. no DC power output from this PSU
Off	Off	Off	No ac power to the server or a problem with the ac power source.	<ol style="list-style-type: none"> <li>1. Check the ac power to the server.</li> <li>2. Make sure that the power cord is connected to a functioning power source.</li> <li>3. Restart the server. If the error remains, check the power-supply LEDs.</li> <li>4. If the problem remains, replace the power-supply.</li> </ol>	This is a normal condition when no ac power is present.
Off	Off	On	The power supply has failed.	Replace the power supply.	
Off	On/ Blinking	Off	The power supply has failed.	Replace the power supply.	
Off	On/ Blinking	On	The power supply has failed.	Replace the power supply.	

DC power-supply LEDs			Description	Action	Notes
IN	OUT	Error (!)			
On	Off	Off	Power-supply not fully seated, faulty system board, or the power supply has failed.	<ol style="list-style-type: none"> <li>1. Reseat the power supply.</li> <li>2. Use the Power Configurator utility to ensure current system power consumption is under limitation. For more information and to download the utility, go to <a href="http://www.ibm.com/systems/bladecenter/resources/powerconfig.html">http://www.ibm.com/systems/bladecenter/resources/powerconfig.html</a>.</li> <li>3. Check the error LEDs on the system board and the IMM2 error messages. Follow steps in "Power problems" on page 90 and "Solving power problems" on page 102 until the problem is solved.</li> </ol>	Typically indicates a power-supply is not fully seated.
On	Off	On	The power supply has failed.	Replace the power supply.	
On	On/ Blinking	On	The power supply has failed.	Replace the power supply.	

## System pulse LEDs

The following LEDs are on the system board and monitor the system power-on and power-off sequencing and boot progress (see "System-board LEDs" on page 33 for the location of these LEDs).

Table 5. System pulse LEDs

LED	Description	Action
IMM2 heartbeat	IMM2 heartbeat boot process.	<p>The following steps describe the different stages of the IMM2 heartbeat sequencing process.</p> <ol style="list-style-type: none"> <li>1. When this LED is blinking fast (approximately 4Hz), this indicates, that the IMM2 code is in the loading process.</li> <li>2. When this LED goes off momentarily, this indicates that the IMM2 code has loaded completely.</li> <li>3. When this LED goes off momentarily and then starts blinking slowing (approximately 1Hz), this indicates that IMM2 is fully operational. You can now press the power-control button to power-on the server.</li> <li>4. If this LED does not blink within 30 seconds of connecting a power source to the server, (trained technician only) replace the system board.</li> </ol>

## PCI riser-card LEDs

The following illustration shows the location of the PCI riser-card LEDs.

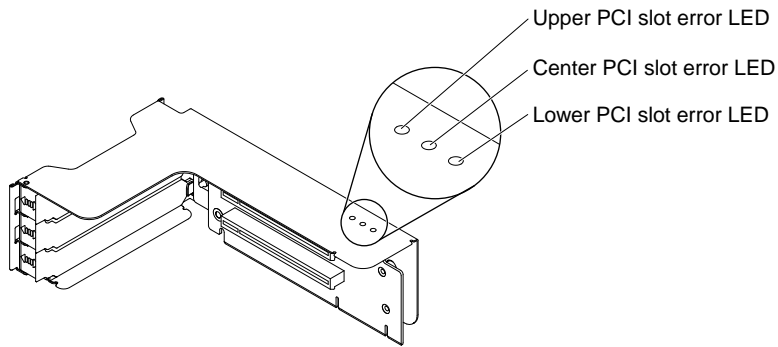

Figure 46. PCI riser-card LEDs

## Event logs

Error codes and messages displayed in POST event log, system-event log, IMM2 event log, and DSA event log.

- **POST event log:** This log contains the most recent error codes and messages that were generated during POST. You can view the contents of the POST event log from the Setup Utility (see “Starting the Setup Utility” on page 47). For more information about POST error codes, see Appendix B “UEFI/POST diagnostic codes” on page 991.
- **System-event log:** This log contains POST and system management interrupt (SMI) events and all events that are generated by the baseboard management controller that is embedded in the integrated management module (IMM). You can view the contents of the system-event log through the Setup Utility and through the Dynamic System Analysis (DSA) program (as IPMI event log). The system-event log is limited in size. When it is full, new entries will not overwrite existing entries; therefore, you must periodically clear the system-event log through the Setup Utility. When you are troubleshooting an error, you might have to save and then clear the system-event log to make the most recent events available for analysis. For more information about the system-event log, see Appendix A “Integrated management module II (IMM2) error messages” on page 313.

Messages are listed on the left side of the screen, and details about the selected message are displayed on the right side of the screen. To move from one entry to the next, use the Up Arrow (↑) and Down Arrow (↓) keys.

Some IMM sensors cause assertion events to be logged when their setpoints are reached. When a setpoint condition no longer exists, a corresponding deassertion event is logged. However, not all events are assertion-type events.

- **IMM2 event log:** This log contains a filtered subset of all IMM, POST, and system management interrupt (SMI) events. You can view the IMM event log through the IMM web interface. For more information, see “Logging in to the Web interface” on page 54. You can also view the IMM event log through the Dynamic System Analysis (DSA) program (as the ASM event log). For more information about IMM error messages, see Appendix A “Integrated management module II (IMM2) error messages” on page 313.
- **DSA event log:** This log is generated by the Dynamic System Analysis (DSA) program, and it is a chronologically ordered merge of the system-event log (as the IPMI event log), the IMM chassis-event log (as the ASM event log), and the operating-system event logs. You can view the DSA event log through the DSA program (see “Viewing event logs without restarting the server” on page 74). For more information about DSA and DSA messages, see “Dynamic System Analysis” on page 75 and Appendix C “DSA diagnostic test results” on page 1013.

## Viewing event logs through the Setup Utility

To view the POST event log or system-event log, complete the following steps:

- Step 1. Turn on the server.
- Step 2. When the prompt <F1> Set up is displayed, press F1. If you have set both a power-on password and an administrator password, you must type the administrator password to view the event logs.
- Step 3. Select **System Event Logs** and use one of the following procedures:
  - To view the POST event log, select **POST Event Viewers**.
  - To view the system-event log, select **System Event Log**.

## Viewing event logs without restarting the server

If the server is not hung and the IMM2 is connected to a network, methods are available for you to view one or more event logs without having to restart the server.

If you have installed Lenovo ToolsCenter Suite CLI (OneCLI), you can use it to view the system-event log (as the IPMI event log), or the IMM2 event log (as the Chassis event log), the operating-system event logs, or the merged OneCLI log. You can also use DSA Preboot to view these logs, although you must restart the server. To install OneCLI or check for and download a later version of OneCLI image, go to:

<https://support.lenovo.com/us/en/documents/LNVO-CENTER>

If IPMItool is installed in the server, you can use it to view the system-event log. Most recent versions of the Linux operating system come with a latest version of IPMItool. For an overview of IPMI, go to <http://www.ibm.com/developerworks/linux/blueprints/> and click **Using Intelligent Platform Management Interface (IPMI) on Lenovo Linux platforms**.

You can view the IMM2 event log through the **Event Log** link in the IMM2 Web interface. For more information, see “Logging in to the Web interface” on page 54.

The following table describes the methods that you can use to view the event logs, depending on the condition of the server. The first three conditions generally do not require that you restart the server.

Table 6. Methods for viewing event logs

Condition	Action
The server is not hung and is connected to a network (using an operating system controlled network ports).	Use any of the following methods: <ul style="list-style-type: none"><li>• Run OneCLI to view the system event log (requires IPMI driver) or create an output file that you can send to Lenovo service and support (using ftp or local copy).</li><li>• Use IPMItool to view the system-event log (requires the IPMI driver).</li><li>• Use the Web browser interface to the IMM2 to view the system-event log locally (requires RNDIS USB LAN driver).</li></ul>
The server is not hung and is not connected to a network (using an operating system controlled network ports).	<ul style="list-style-type: none"><li>• Run OneCLI to view the system event log (requires IPMI driver) or create an output file that you can send to Lenovo service and support (using ftp or local copy).</li><li>• Use IPMItool to view the system-event log (requires the IPMI driver).</li><li>• Use the Web browser interface to the IMM2 to view the system-event log locally (requires RNDIS USB LAN driver).</li></ul>

Table 6. Methods for viewing event logs (continued)

Condition	Action
The server is not hung and the IMM2 is connected to a network.	In a Web browser, type the IP address for the IMM2 and go to the <b>Event Log</b> page. For more information, see “Obtaining the IMM host name” on page 53 and “Logging in to the Web interface” on page 54.
The server is hung, and no communication can be made with the IMM2.	<ul style="list-style-type: none"> <li>• If DSA Preboot is installed, restart the server and press F2 to start DSA Preboot and view the event logs. For more information, see “Running the DSA Preboot diagnostic programs” on page 76.</li> <li>• Alternatively, you can restart the server and press F1 to start the Setup Utility and view the POST event log or system-event log. For more information, see “Viewing event logs through the Setup Utility” on page 74.</li> </ul>

## Clearing the event logs

Use this information to clear the event logs.

To clear the event logs, complete the following steps.

**Note:** The POST error log is automatically cleared each time the server is restarted.

Step 1. Turn on the server.

Step 2. When the prompt <F1> Set up is displayed, press F1. If you have set both a power-on password and an administrator password, you must type the administrator password to view the event logs.

Step 3. To clear the IMM system-event log, select **System Event Logs → Clear System Event Log**, then, press **Enter** twice.

## POST

When you turn on the server, it performs a series of tests to check the operation of the server components and some optional devices in the server. This series of tests is called the power-on self-test, or POST.

**Note:** This server does not use beep codes for server status.

If a power-on password is set, you must type the password and press **Enter** (when you are prompted), for POST to run.

If POST detects a problem, an error message is displayed. See Appendix B “UEFI/POST diagnostic codes” on page 991 for more information.

If POST detects a problem, an error message is sent to the POST event log, see “Event logs” on page 73 for more information.

## Dynamic System Analysis

Dynamic System Analysis (DSA) collects and analyzes system information to aid in diagnosing server problems. Lenovo provides DSA Preboot edition to users.

DSA collects the following information about the server:

- Drive health information
- Event logs for ServeRAID controllers and service processors
- Hardware inventory, including PCI and USB information
- Light path diagnostics status
- Network interfaces and settings

- Performance data and details about processes that are running
- RAID controller configuration
- Service processor (IMM2) status and configuration
- System configuration
- Vital product data and firmware information

For system-specific information about the action that you should take as a result of a message that DSA generates, see Appendix C “DSA diagnostic test results” on page 1013.

If you cannot find a problem by using DSA, see “Solving undetermined problems” on page 105 for information about testing the server.

**Note:** DSA Preboot might appear to be unresponsive when you start the program. This is normal operation while the program loads.

Make sure that the server has the latest version of the DSA code. To obtain DSA codes and the *Dynamic System Analysis Installation and User's Guide*, go to:  
<https://support.lenovo.com/us/en/documents/LNVO-DSA>

## DSA Preboot

This topic introduces DSA Preboot.

DSA Preboot runs outside of the operating system; you must restart the server to run it. It is provided in the flash memory on the server, or you can create a bootable media such as a CD, DVD, ISO, USB, or PXE using the ToolsCenter Bootable Media Creator (BoMC). For more details, see the *BoMC User Guide* at <https://support.lenovo.com/us/en/documents/LNVO-BOMC>. In addition to the capabilities of the other editions of DSA, DSA Preboot includes diagnostic routines that would be disruptive to run within the operating-system environment (such as resetting devices and causing loss of network connectivity). It has a graphical user interface that you can use to specify which diagnostics to run and to view the diagnostic and data collection results.

DSA Preboot provides diagnostics for the following system components, if they are installed:

- Emulex network adapter
- Optical devices (CD or DVD)
- Memory
- Microprocessor
- Checkpoint panel
- I2C bus
- SAS and SATA drives

If you are able to restart the server or if you need comprehensive diagnostics, use DSA Preboot.

For more information and to download the utilities, go to <https://support.lenovo.com/us/en/documents/LNVO-DSA>.

## Running the DSA Preboot diagnostic programs

Use this information to run the DSA Preboot diagnostic programs.

**Note:** The DSA memory test might take up to 30 minutes to run. If the problem is not a memory problem, skip the memory test.



To run the DSA Preboot diagnostic programs, complete the following steps:

Step 1. If the server is running, turn off the server and all attached devices.

Step 2. Turn on all attached devices; then, turn on the server.

Step 3. When the prompt <F2> Diagnostics is displayed, press F2.

**Note:** The DSA Preboot diagnostic program might appear to be unresponsive for an unusual length of time when you start the program. This is normal operation while the program loads. The loading process may take up to 10 minutes.

Step 4. Optionally, select **Quit to DSA** to exit from the stand-alone memory diagnostic program.

**Note:** After you exit from the stand-alone memory diagnostic environment, you must restart the server to access the stand-alone memory diagnostic environment again.

Step 5. Type **gui** to display the graphical user interface, or type **cmd** to display the DSA interactive menu.

Step 6. Follow the instructions on the screen to select the diagnostic test to run.

If the diagnostic programs do not detect any hardware errors but the problem remains during normal server operation, a software error might be the cause. If you suspect a software problem, see the information that comes with your software.

A single problem might cause more than one error message. When this happens, correct the cause of the first error message. The other error messages usually will not occur the next time you run the diagnostic programs.

If the server stops during testing and you cannot continue, restart the server and try running the DSA Preboot diagnostic programs again. If the problem remains, replace the component that was being tested when the server stopped.

## Diagnostic text messages

Diagnostic text messages are displayed while the tests are running.

A diagnostic text message contains one of the following results:

**Passed:** The test was completed without any errors.

**Failed:** The test detected an error.

**Aborted:** The test could not proceed because of the server configuration

Additional information concerning test failures is available in the extended diagnostic results for each test.

## Viewing the test log results and transferring the DSA collection

To view the test log for the results when the tests are completed, click the **Success** link in the Status column, if you are running the DSA graphical user interface, or type `:x` to exit the Execute Tests menu, if you are running the DSA interactive menu, or select **Diagnostic Event Log** in the graphical user interface. To transfer DSA Preboot collections to an external USB device, type the `copy` command in the DSA interactive menu.

- If you are running the DSA graphical user interface (GUI), click the **Success** link in the Status column.
- If you are running the DSA interactive menu (CLI), type `:x` to exit the Execute Tests menu; then, select **completed tests** to view the results.

You can also send the DSA error log to Lenovo support to aid in diagnosing the server problems.

---

## Automated service request (call home)

Lenovo provides tools that can automatically collect and send data or call Lenovo Support when an error is detected. These tools can help Lenovo Support speed up the process of diagnosing problems. The following sections provide information about the call home tools.

### Electronic Service Agent

Electronic Service Agent monitors, tracks, and captures system hardware errors and hardware and software inventory information, and reports serviceable problems directly to Lenovo Support.

You can also choose to collect data manually. It uses minimal system resources, and can be downloaded from the website. For more information and to download Electronic Service Agent, go to <http://www-01.ibm.com/support/esa/>.

---

## Error messages

This section provides the list of error codes and messages for UEFI/POST, IMM2, and DSA that are generated when a problem is detected.

See Appendix B “UEFI/POST diagnostic codes” on page 991, Appendix A “Integrated management module II (IMM2) error messages” on page 313, and Appendix C “DSA diagnostic test results” on page 1013 for more information.

---

## Troubleshooting by symptom

Use the troubleshooting tables to find solutions to problems that have identifiable symptoms.

If you cannot find a solution to the problem in these tables, see Appendix C “DSA diagnostic test results” on page 1013 for information about testing the server and “Running the DSA Preboot diagnostic programs” on page 76 for additional information about running DSA Preboot program. For additional information to help you solve problems, see “Start here” on page 63.

If you have just added new software or a new optional device and the server is not working, complete the following steps before you use the troubleshooting tables:

- Step 1. Check the system-error LED on the operator information panel; if it is lit, check the LCD system information display panel (if available).
- Step 2. Remove the software or device that you just added.
- Step 3. Run Dynamic System Analysis (DSA) to determine whether the server is running correctly (for information about using DSA, see Appendix C “DSA diagnostic test results” on page 1013).
- Step 4. Reinstall the new software or new device.

### CD/DVD drive problems

Use the troubleshooting tables to find solutions to problems that have identifiable symptoms.

- Follow the suggested actions in the order in which they are listed in the Action column until the problem is solved.
- If an action step is preceded by “(Trained technician only),” that step must be performed only by a Trained technician.
- Go to the support website at <http://www.lenovo.com/support> to check for technical information, hints, tips, and new device drivers or to submit a request for information.

Symptom	Action
The optional DVD drive is not recognized.	<ol style="list-style-type: none"> <li>1. Make sure that: <ul style="list-style-type: none"> <li>• The SATA connector to which the DVD drive is attached is enabled in the Setup Utility.</li> <li>• All cables and jumpers are installed correctly.</li> <li>• The correct device driver is installed for the DVD drive.</li> </ul> </li> <li>2. Run the DVD drive diagnostic programs.</li> <li>3. Reseat the following components: <ol style="list-style-type: none"> <li>a. DVD drive</li> <li>b. DVD drive cable</li> </ol> </li> <li>4. Replace the components listed in step 3 one at a time, in the order shown, restarting the server each time.</li> <li>5. (Trained technician only) Replace the system board.</li> </ol>
A CD or DVD is not working correctly.	<ol style="list-style-type: none"> <li>1. Clean the CD or DVD.</li> <li>2. Replace the CD or DVD with new CD or DVD media.</li> <li>3. Run the DVD drive diagnostic programs.</li> <li>4. Reseat the DVD drive.</li> <li>5. Replace the DVD drive.</li> </ol>
The DVD drive tray is not working.	<ol style="list-style-type: none"> <li>1. Make sure that the server is turned on.</li> <li>2. Insert the end of a straightened paper clip into the manual tray-release opening.</li> <li>3. Reseat the DVD drive.</li> <li>4. Replace the DVD drive.</li> </ol>

## General problems

Use the troubleshooting tables to find solutions to problems that have identifiable symptoms.

- Follow the suggested actions in the order in which they are listed in the Action column until the problem is solved.
- If an action step is preceded by “(Trained technician only),” that step must be performed only by a trained technician.
- Go to the support website at <http://www.lenovo.com/support> to check for technical information, hints, tips, and new device drivers or to submit a request for information.

Symptom	Action
A cover latch is broken, an LED is not working, or a similar problem has occurred.	If the part is a CRU, replace it. If the part is a microprocessor or the system board, the part must be replaced by a trained technician.
The server is hung while the screen is on. Cannot start the Setup Utility by pressing F1.	<ol style="list-style-type: none"> <li>1. See “Nx-boot failure” on page 110 for more information.</li> <li>2. See “Recovering the server firmware (UEFI update failure)” on page 107 for more information.</li> </ol>

## Hard disk drive problems

Use the troubleshooting tables to find solutions to problems that have identifiable symptoms.

- Follow the suggested actions in the order in which they are listed in the Action column until the problem is solved.
- If an action step is preceded by “(Trained technician only),” that step must be performed only by a trained technician.
- Go to the support website at <http://www.lenovo.com/support> to check for technical information, hints, tips, and new device drivers or to submit a request for information.

Symptom	Action
A hard disk drive has failed, and the associated yellow hard disk drive status LED is lit.	Replace the failed hard disk drive (see “Removing a hot-swap hard disk drive” on page 153 and “Replacing a hot-swap hard disk drive” on page 154).
A newly installed hard disk drive is not recognized.	<ol style="list-style-type: none"> <li>1. Make sure that the installed hard disk drive or ServeRAID adapter is supported. For a list of supported optional devices, see <a href="http://www.lenovo.com/serverproven/">http://www.lenovo.com/serverproven/</a>.</li> <li>2. Observe the associated yellow hard disk drive status LED. If the LED is lit, it indicates a drive fault.</li> <li>3. If the LED is lit, remove the drive from the bay, wait 45 seconds, and reinsert the drive, making sure that the drive assembly connects to the hard disk drive backplane.</li> <li>4. Observe the associated green hard disk drive activity LED and the yellow status LED: <ul style="list-style-type: none"> <li>• If the green activity LED is flashing and the yellow status LED is not lit, the drive is recognized by the controller and is working correctly. Run the DSA diagnostics program to determine whether the drive is detected.</li> <li>• If the green activity LED is flashing and the yellow status LED is flashing slowly, the drive is recognized by the controller and is rebuilding.</li> <li>• If neither LED is lit or flashing, check the hard disk drive backplane (go to 5 on page 81).</li> <li>• If the green activity LED is flashing and the yellow status LED is lit, replace the drive. If the activity of the LEDs remains the same, go to 5 on page 81. If the activity of the LEDs changes, return to 2 on page 81.</li> </ul> </li> <li>5. Make sure that the hard disk drive backplane is correctly seated. When it is correctly seated, the drive assemblies correctly connect to the backplane without bowing or causing movement of the backplane.</li> <li>6. Reseat the backplane power cable and repeat steps 2 on page 81 through 4 on page 81.</li> <li>7. Reseat the backplane signal cable and repeat steps 2 on page 81 through 4 on page 81.</li> <li>8. Suspect the backplane signal cable or the backplane: <ul style="list-style-type: none"> <li>• If the server has hot-swap bays: <ol style="list-style-type: none"> <li>a. Replace the affected backplane signal cable.</li> <li>b. Replace the affected backplane.</li> </ol> </li> </ul> </li> <li>9. See “Problem determination tips” on page 106.</li> </ol>
Multiple hard disk drives fail.	<p>Make sure that the hard disk drive, SAS/SATA adapter, and server device drivers and firmware are at the latest level.</p> <p><b>Important:</b> Some cluster solutions require specific code levels or coordinated code updates. If the device is part of a cluster solution, verify that the latest level of code is supported for the cluster solution before you update the code.</p>

- Follow the suggested actions in the order in which they are listed in the Action column until the problem is solved.
- If an action step is preceded by “(Trained technician only),” that step must be performed only by a trained technician.
- Go to the support website at <http://www.lenovo.com/support> to check for technical information, hints, tips, and new device drivers or to submit a request for information.

Symptom	Action
Multiple hard disk drives are offline.	<ol style="list-style-type: none"> <li>1. Review the storage subsystem logs for indications of problems within the storage subsystem, such as backplane or cable problems.</li> <li>2. See “Problem determination tips” on page 106.</li> </ol>
A replacement hard disk drive does not rebuild.	<ol style="list-style-type: none"> <li>1. Make sure that the hard disk drive is recognized by the adapter (the green hard disk drive activity LED is flashing).</li> <li>2. Review the SAS/SATA adapter documentation to determine the correct configuration parameters and settings.</li> </ol>
A green hard disk drive activity LED does not accurately represent the actual state of the associated drive.	<p>If the green hard disk drive activity LED does not flash when the drive is in use, run the DSA Preboot diagnostic programs to collect error logs (see “Running the DSA Preboot diagnostic programs” on page 76).</p> <ul style="list-style-type: none"> <li>• If there is a hard disk drive error log, replace the affected hard disk drive.</li> <li>• If there is no disk drive error log error log, replace the affected backplane.</li> </ul>
An yellow hard disk drive status LED does not accurately represent the actual state of the associated drive.	<ol style="list-style-type: none"> <li>1. If the yellow hard disk drive LED and the RAID adapter software do not indicate the same status for the drive, complete the following steps: <ol style="list-style-type: none"> <li>a. Turn off the server.</li> <li>b. Reseat the SAS/SATA adapter.</li> <li>c. Reseat the backplane signal/power cable.</li> <li>d. Reseat the hard disk drive.</li> <li>e. Turn on the server and observe the activity of the hard disk drive LEDs.</li> </ol> </li> <li>2. See “Problem determination tips” on page 106.</li> </ol>

## Hypervisor problems

Use the troubleshooting tables to find solutions to problems that have identifiable symptoms.

<ul style="list-style-type: none"> <li>• Follow the suggested actions in the order in which they are listed in the Action column until the problem is solved.</li> <li>• If an action step is preceded by “(Trained technician only),” that step must be performed only by a trained technician.</li> <li>• Go to the support website at <a href="http://www.lenovo.com/support">http://www.lenovo.com/support</a> to check for technical information, hints, tips, and new device drivers or to submit a request for information.</li> </ul>	
Symptom	Action
If an optional embedded hypervisor flash device is not listed in the expected boot order, does not appear in the list of boot devices, or a similar problem has occurred.	<ol style="list-style-type: none"> <li>1. Make sure that the optional embedded hypervisor flash device is selected on the boot manager &lt;F12&gt; Select Boot Device at startup.</li> <li>2. Make sure that the embedded hypervisor flash device is seated in the connector correctly (see “Removing a USB embedded hypervisor flash device” on page 246 and “Replacing a USB embedded hypervisor flash device” on page 246).</li> <li>3. See the documentation that comes with the optional embedded hypervisor flash device for setup and configuration information.</li> <li>4. Make sure that other software works on the server.</li> </ol>

## Intermittent problems

Use the troubleshooting tables to find solutions to problems that have identifiable symptoms.

<ul style="list-style-type: none"> <li>• Follow the suggested actions in the order in which they are listed in the Action column until the problem is solved.</li> <li>• If an action step is preceded by “(Trained technician only),” that step must be performed only by a trained technician.</li> <li>• Go to the support website at <a href="http://www.lenovo.com/support">http://www.lenovo.com/support</a> to check for technical information, hints, tips, and new device drivers or to submit a request for information.</li> </ul>	
Symptom	Action
A problem occurs only occasionally and is difficult to diagnose.	<ol style="list-style-type: none"> <li>1. Make sure that: <ul style="list-style-type: none"> <li>• All cables and cords are connected securely to the rear of the server and attached devices.</li> <li>• When the server is turned on, air is flowing from the fan grille. If there is no airflow, the fan is not working. This can cause the server to overheat and shut down.</li> </ul> </li> <li>2. Check the system-error log or IMM event logs (see “Event logs” on page 73).</li> </ol>
The server resets (restarts) occasionally.	<ol style="list-style-type: none"> <li>1. If the reset occurs during POST and the POST watchdog timer is enabled (click <b>System Settings</b> → <b>Recovery</b> → <b>System Recovery</b> → <b>POST Watchdog Timer</b> in the Setup Utility to see the POST watchdog setting), make sure that sufficient time is allowed in the watchdog timeout value (<b>POST Watchdog Timer</b>). If the server continues to reset during POST, see Appendix B “UEFI/POST diagnostic codes” on page 991 and Appendix C “DSA diagnostic test results” on page 1013.</li> <li>2. If neither condition applies, check the system-error log or IMM system-event log (see “Event logs” on page 73).</li> </ol>

## Keyboard, mouse, or USB-device problems

Use the troubleshooting tables to find solutions to problems that have identifiable symptoms.

- Follow the suggested actions in the order in which they are listed in the Action column until the problem is solved.
- If an action step is preceded by “(Trained technician only),” that step must be performed only by a trained technician.
- Go to the support website at <http://www.lenovo.com/support> to check for technical information, hints, tips, and new device drivers or to submit a request for information.

Symptom	Action
All or some keys on the keyboard do not work.	<ol style="list-style-type: none"> <li>1. Make sure that: <ul style="list-style-type: none"> <li>• The keyboard cable is securely connected.</li> <li>• The server and the monitor are turned on.</li> </ul> </li> <li>2. If you are using a USB keyboard, run the Setup Utility and enable keyboardless operation.</li> <li>3. If you are using a USB keyboard and it is connected to a USB hub, disconnect the keyboard from the hub and connect it directly to the server.</li> <li>4. Replace the keyboard.</li> </ol>
The mouse or USB-device does not work.	<ol style="list-style-type: none"> <li>1. Make sure that: <ul style="list-style-type: none"> <li>• The mouse or USB device cable is securely connected to the server.</li> <li>• The mouse or USB device drivers are installed correctly.</li> <li>• The server and the monitor are turned on.</li> <li>• The mouse option is enabled in the Setup Utility.</li> </ul> </li> <li>2. If you are using a USB mouse or USB device and it is connected to a USB hub, disconnect the mouse or USB device from the hub and connect it directly to the server.</li> <li>3. Replace the mouse or USB-device.</li> </ol>

## Memory problems

Use the troubleshooting tables to find solutions to problems that have identifiable symptoms.



- Follow the suggested actions in the order in which they are listed in the Action column until the problem is solved.
- If an action step is preceded by “(Trained technician only),” that step must be performed only by a trained technician.
- Go to the support website at <http://www.lenovo.com/support> to check for technical information, hints, tips, and new device drivers or to submit a request for information.

Symptom	Action
<p>The amount of system memory that is displayed is less than the amount of installed physical memory.</p>	<p><b>Note:</b> Each time you install or remove a DIMM, you must disconnect the server from the power source; then, wait 10 seconds before restarting the server.</p> <ol style="list-style-type: none"> <li>1. Make sure that: <ul style="list-style-type: none"> <li>• No error LEDs are lit on the operator information panel.</li> <li>• No DIMM error LEDs are lit on the system board.</li> <li>• Memory mirrored channel does not account for the discrepancy.</li> <li>• The memory modules are seated correctly.</li> <li>• You have installed the correct type of memory.</li> <li>• If you changed the memory, you updated the memory configuration in the Setup Utility.</li> <li>• All banks of memory are enabled. The server might have automatically disabled a memory bank when it detected a problem, or a memory bank might have been manually disabled.</li> <li>• There is no memory mismatch when the server is at the minimum memory configuration.</li> </ul> </li> <li>2. Reseat the DIMMs, and then restart the server.</li> <li>3. Check the POST error log: <ul style="list-style-type: none"> <li>• If a DIMM was disabled by a systems-management interrupt (SMI), replace the DIMM.</li> <li>• If a DIMM was disabled by the user or by POST, reseat the DIMM; then, run the Setup Utility and enable the DIMM.</li> </ul> </li> <li>4. Check that all DIMMs are initialized in the Setup Utility; then, run memory diagnostics (see “Running the DSA Preboot diagnostic programs” on page 76).</li> <li>5. Reverse the DIMMs between the channels (of the same microprocessor), and then restart the server. If the problem is related to a DIMM, replace the failing DIMM.</li> <li>6. Re-enable all DIMMs using the Setup Utility, and then restart the server.</li> <li>7. (Trained technician only) Install the failing DIMM into a DIMM connector for microprocessor 2 (if installed) to verify that the problem is not the microprocessor or the DIMM connector.</li> <li>8. (Trained technician only) Replace the system board.</li> </ol>
<p>Multiple DIMMs in a channel are identified as failing.</p>	<p><b>Note:</b> Each time you install or remove a DIMM, you must disconnect the server from the power source; then, wait 10 seconds before restarting the server.</p> <ol style="list-style-type: none"> <li>1. Reseat the DIMMs; then, restart the server.</li> <li>2. Remove the highest-numbered DIMM of those that are identified and replace it with an identical known good DIMM; then, restart the server. Repeat as necessary. If the failures continue after all identified DIMMs are replaced, go to step 4.</li> <li>3. Return the removed DIMMs, one at a time, to their original connectors, restarting the server after each DIMM, until a DIMM fails. Replace each failing DIMM with an identical known good DIMM, restarting the server after each DIMM replacement. Repeat step 3 until you have tested all removed DIMMs.</li> </ol>

<ul style="list-style-type: none"> <li>• Follow the suggested actions in the order in which they are listed in the Action column until the problem is solved.</li> <li>• If an action step is preceded by “(Trained technician only),” that step must be performed only by a trained technician.</li> <li>• Go to the support website at <a href="http://www.lenovo.com/support">http://www.lenovo.com/support</a> to check for technical information, hints, tips, and new device drivers or to submit a request for information.</li> </ul>	
Symptom	Action
	<ol style="list-style-type: none"> <li>4. Replace the highest-numbered DIMM of those identified; then, restart the server. Repeat as necessary.</li> <li>5. Reverse the DIMMs between the channels (of the same microprocessor), and then restart the server. If the problem is related to a DIMM, replace the failing DIMM.</li> <li>6. (Trained technician only) Install the failing DIMM into a DIMM connector for microprocessor 2 (if installed) to verify that the problem is not the microprocessor or the DIMM connector.</li> <li>7. (Trained technician only) Replace the system board.</li> </ol>

## Microprocessor problems

Use the troubleshooting tables to find solutions to problems that have identifiable symptoms.

<ul style="list-style-type: none"> <li>• Follow the suggested actions in the order in which they are listed in the Action column until the problem is solved.</li> <li>• If an action step is preceded by “(Trained technician only),” that step must be performed only by a trained technician.</li> <li>• Go to the support website at <a href="http://www.lenovo.com/support">http://www.lenovo.com/support</a> to check for technical information, hints, tips, and new device drivers or to submit a request for information.</li> </ul>	
Symptom	Action
The server goes directly to the POST Event Viewer when it is turned on.	<ol style="list-style-type: none"> <li>1. Correct any errors that are indicated by the LCD system information display panel (if available).</li> <li>2. Make sure that the server supports all the microprocessors and that the microprocessors match in speed and cache size. To view the microprocessor information, run the Setup Utility and select <b>System Information → System Summary → Processor Details</b>.</li> <li>3. (Trained technician only) Make sure that microprocessor 1 is seated correctly.</li> <li>4. (Trained technician only) Remove microprocessor 2 and restart the server.</li> <li>5. Replace the following components one at a time, in the order shown, restarting the server each time:             <ol style="list-style-type: none"> <li>a. (Trained technician only) Microprocessor</li> <li>b. (Trained technician only) System board</li> </ol> </li> </ol>

## Monitor and video problems

Some monitors have their own self-tests. If you suspect a problem with your monitor, see the documentation that comes with the monitor for instructions for testing and adjusting the monitor. If you cannot diagnose the problem, call for service.

- Follow the suggested actions in the order in which they are listed in the Action column until the problem is solved.
- If an action step is preceded by “(Trained technician only),” that step must be performed only by a trained technician.
- Go to the support website at <http://www.lenovo.com/support> to check for technical information, hints, tips, and new device drivers or to submit a request for information.

Symptom	Action
Testing the monitor.	<ol style="list-style-type: none"> <li>1. Make sure that the monitor cables are firmly connected.</li> <li>2. Try using a different monitor on the server, or try using the monitor that is being tested on a different server.</li> <li>3. Run the diagnostic programs. If the monitor passes the diagnostic programs, the problem might be a video device driver.</li> <li>4. (Trained technician only) Replace the system board.</li> </ol>
The screen is blank.	<ol style="list-style-type: none"> <li>1. If the server is attached to a KVM switch, bypass the KVM switch to eliminate it as a possible cause of the problem: connect the monitor cable directly to the correct connector on the rear of the server.</li> <li>2. The IMM2 remote presence function is disabled if you install an optional video adapter. To use the IMM2 remote presence function, remove the optional video adapter.</li> <li>3. If the server installed with the graphical adapters while turning on the server, the logo displays on the screen after approximately 3 minutes. This is normal operation while the system loads.</li> <li>4. Make sure that: <ul style="list-style-type: none"> <li>• The server is turned on. If there is no power to the server, see “Power problems” on page 90.</li> <li>• The monitor cables are connected correctly.</li> <li>• The monitor is turned on and the brightness and contrast controls are adjusted correctly.</li> </ul> </li> <li>5. Make sure that the correct server is controlling the monitor, if applicable.</li> <li>6. Make sure that damaged server firmware is not affecting the video; see “Updating the firmware” on page 43.</li> <li>7. Replace the following components one at a time, in the order shown, restarting the server each time: <ol style="list-style-type: none"> <li>a. Monitor</li> <li>b. Video adapter (if one is installed)</li> <li>c. (Trained technician only) System board.</li> </ol> </li> <li>8. See “Solving undetermined problems” on page 105.</li> </ol>
The monitor works when you turn on the server, but the screen goes blank when you start some application programs.	<ol style="list-style-type: none"> <li>1. Make sure that: <ul style="list-style-type: none"> <li>• The application program is not setting a display mode that is higher than the capability of the monitor.</li> <li>• You installed the necessary device drivers for the application.</li> </ul> </li> <li>2. Run video diagnostics (see “Running the DSA Preboot diagnostic programs” on page 76). <ul style="list-style-type: none"> <li>• If the server passes the video diagnostics, the video is good; see “Solving undetermined problems” on page 105.</li> <li>• (Trained technician only) If the server fails the video diagnostics, replace the system board.</li> </ul> </li> </ol>

- Follow the suggested actions in the order in which they are listed in the Action column until the problem is solved.
- If an action step is preceded by “(Trained technician only),” that step must be performed only by a trained technician.
- Go to the support website at <http://www.lenovo.com/support> to check for technical information, hints, tips, and new device drivers or to submit a request for information.

Symptom	Action
<p>The monitor has screen jitter, or the screen image is wavy, unreadable, rolling, or distorted.</p>	<ol style="list-style-type: none"> <li>1. If the monitor self-tests show that the monitor is working correctly, consider the location of the monitor. Magnetic fields around other devices (such as transformers, appliances, fluorescents, and other monitors) can cause screen jitter or wavy, unreadable, rolling, or distorted screen images. If this happens, turn off the monitor. <p><b>Attention:</b> Moving a color monitor while it is turned on might cause screen discoloration.</p> <p>Move the device and the monitor at least 305 mm (12 in.) apart, and turn on the monitor.</p> <p><b>Notes:</b></p> <ol style="list-style-type: none"> <li>a. To prevent diskette drive read/write errors, make sure that the distance between the monitor and any external diskette drive is at least 76 mm (3 in.).</li> <li>b. Non-Lenovo monitor cables might cause unpredictable problems.</li> </ol> </li> <li>2. Reseat the monitor cable.</li> <li>3. Replace the components listed in step 2 one at a time, in the order shown, restarting the server each time: <ol style="list-style-type: none"> <li>a. Monitor cable</li> <li>b. Video adapter (if one is installed)</li> <li>c. Monitor</li> <li>d. (Trained technician only) System board.</li> </ol> </li> </ol>
<p>Wrong characters appear on the screen.</p>	<ol style="list-style-type: none"> <li>1. If the wrong language is displayed, update the server firmware to the latest level (see “Updating the firmware” on page 43) with the correct language.</li> <li>2. Reseat the monitor cable.</li> <li>3. Replace the components listed in step 2 one at a time, in the order shown, restarting the server each time: <ol style="list-style-type: none"> <li>a. Monitor cable</li> <li>b. Video adapter (if one is installed)</li> <li>c. Monitor</li> <li>d. (Trained technician only) System board.</li> </ol> </li> </ol>

## Network connection problems

Use the troubleshooting tables to find solutions to problems that have identifiable symptoms.

- Follow the suggested actions in the order in which they are listed in the Action column until the problem is solved.
- If an action step is preceded by “(Trained technician only),” that step must be performed only by a trained technician.
- Go to the support website at <http://www.lenovo.com/support> to check for technical information, hints, tips, and new device drivers or to submit a request for information.

Symptom	Action
Unable to wake the server using the Wake on LAN feature.	<ol style="list-style-type: none"> <li>1. If you are using the ML2 network adapter and the server is connected to the network using slot 3 connector, check the system-error log or IMM2 system event log (see “Event logs” on page 73), make sure:               <ol style="list-style-type: none"> <li>a. FAN1 and FAN2 are running in standby mode if ML2 adapter is installed..</li> <li>b. The room temperature is not too high (see “Server features and specifications” on page 6).</li> <li>c. The air vents are not blocked.</li> <li>d. The air baffle is installed securely.</li> </ol> </li> <li>2. Reseat the ML2 network adapter (see “Removing an adapter” on page 185 and “Replacing an adapter” on page 189).</li> <li>3. Turn off the server and disconnect it from the power source; then, wait 10 seconds before restarting the server.</li> <li>4. If the problem still remains, replace the dual-port network adapter.</li> </ol>
Log in failed by using LDAP account with SSL enabled.	<ol style="list-style-type: none"> <li>1. Make sure the license key is valid.</li> <li>2. Generate a new license key and log in again.</li> </ol>

## Optional-device problems

Use the troubleshooting tables to find solutions to problems that have identifiable symptoms.

- Follow the suggested actions in the order in which they are listed in the Action column until the problem is solved.
- If an action step is preceded by “(Trained technician only),” that step must be performed only by a trained technician.
- Go to the support website at <http://www.lenovo.com/support> to check for technical information, hints, tips, and new device drivers or to submit a request for information.

Symptom	Action
An optional device that was just installed does not work.	<ol style="list-style-type: none"> <li>1. Make sure that: <ul style="list-style-type: none"> <li>• The device is designed for the server (see <a href="http://www.lenovo.com/serverproven/">http://www.lenovo.com/serverproven/</a>).</li> <li>• You followed the installation instructions that came with the device and the device is installed correctly.</li> <li>• You have not loosened any other installed devices or cables.</li> <li>• You updated the configuration information in the Setup Utility. Whenever memory or any other device is changed, you must update the configuration.</li> </ul> </li> <li>2. Reseat the device that you just installed.</li> <li>3. Replace the device that you just installed.</li> </ol>
An optional device that worked previously does not work now.	<ol style="list-style-type: none"> <li>1. Make sure that all of the cable connections for the device are secure.</li> <li>2. If the device comes with test instructions, use those instructions to test the device.</li> <li>3. If the failing device is a SAS/SATA device, make sure that: <ul style="list-style-type: none"> <li>• The cables for all external SAS and SATA devices are connected correctly.</li> <li>• The last device in each SAS and SATA chain, or the end of the SAS and SATA cable, is terminated correctly.</li> <li>• Any external SAS and SATA device is turned on. You must turn on an external SAS and SATA device before you turn on the server.</li> </ul> </li> <li>4. Reseat the failing device.</li> <li>5. Replace the failing device.</li> </ol>

## Power problems

Use the troubleshooting tables to find solutions to problems that have identifiable symptoms.

- Follow the suggested actions in the order in which they are listed in the Action column until the problem is solved.
- If an action step is preceded by “(Trained technician only),” that step must be performed only by a trained technician.
- Go to the support website at <http://www.lenovo.com/support> to check for technical information, hints, tips, and new device drivers or to submit a request for information.

Symptom	Action
<p>The power-control button does not work, and the reset button does not work (the server does not start).</p> <p><b>Note:</b> The power-control button will not function until approximately 5 to 10 seconds after the server has been connected to power.</p>	<ol style="list-style-type: none"> <li>1. Make sure that the power-control button is working correctly:               <ol style="list-style-type: none"> <li>a. Disconnect the server power cords.</li> <li>b. Reconnect the power cords.</li> <li>c. (Trained technician only) Reseat the operator information panel cable, and then repeat steps a. on page 91 and b. on page 91.                   <ul style="list-style-type: none"> <li>• (Trained technician only) If the server starts, reseat the operator information panel. If the problem remains, replace the operator information panel.</li> <li>• If the server does not start, bypass the power-control button by using the force power-on jumper (see “System-board switches, jumpers, and buttons” on page 30). If the server starts, reseat the operator information panel. If the problem remains, replace the operator information panel.</li> </ul> </li> </ol> </li> <li>2. Make sure that the reset button is working correctly:               <ol style="list-style-type: none"> <li>a. Disconnect the server power cords.</li> <li>b. Reconnect the power cords.</li> <li>c. (Trained technician only) Reseat the operator information panel cable, and then repeat steps a. on page 91 and b. on page 91.                   <ul style="list-style-type: none"> <li>• (Trained technician only) If the server starts, replace the operator information panel.</li> <li>• If the server does not start, go to 3 on page 91.</li> </ul> </li> </ol> </li> <li>3. Make sure that both power supplies installed in the server are of the same type. Mixing different ratings of power supplies in the server will cause a system error (CONFIG icon will be shown on the LCD system information display panel if one is available).</li> <li>4. Make sure that:               <ul style="list-style-type: none"> <li>• The power cords are correctly connected to the server and to a working electrical outlet.</li> <li>• The type of memory that is installed is correct.</li> <li>• The DIMMs are fully seated.</li> <li>• The LEDs on the power supply do not indicate a problem.</li> <li>• The microprocessors are installed in the correct sequence.</li> </ul> </li> <li>5. Reseat the following components:               <ol style="list-style-type: none"> <li>a. Operator information panel connector</li> <li>b. Power supplies</li> </ol> </li> <li>6. Replace the components listed in step 5 on page 91 one at a time, in the order shown, restarting the server each time.</li> <li>7. If you just installed an optional device, remove it, and restart the server. If the server now starts, you might have installed more devices than the power supply supports.</li> <li>8. See “Power-supply LEDs” on page 69.</li> <li>9. See “Solving undetermined problems” on page 105.</li> </ol>

- Follow the suggested actions in the order in which they are listed in the Action column until the problem is solved.
- If an action step is preceded by “(Trained technician only),” that step must be performed only by a trained technician.
- Go to the support website at <http://www.lenovo.com/support> to check for technical information, hints, tips, and new device drivers or to submit a request for information.

Symptom	Action
The Pwr rail A error has been recorded in the system event log.	<ol style="list-style-type: none"> <li>1. Disconnect the server power cords.</li> <li>2. (Trained technician only) remove microprocessor 1 if the Pwr rail A error has been recorded in the system event log.</li> <li>3. (Trained technician only) replace the system board (see “Removing the system board” on page 281 and “Replacing the system board” on page 284).</li> <li>4. Reinstall the component; then, restarting the server. If the Pwr rail A error has been recorded in the system event log again, the component that you just reinstalled is defective. Replace the defective component. <ul style="list-style-type: none"> <li>• (Trained technician only) Microprocessor 1 (see “Removing a microprocessor and heat sink” on page 265 and “Replacing a microprocessor and heat sink” on page 270).</li> </ul> </li> </ol>
The Pwr rail B error has been recorded in the system event log.	<ol style="list-style-type: none"> <li>1. Disconnect the server power cords.</li> <li>2. Remove DIMMs 1 through 12 if Pwr rail B error has been recorded in the system event log.</li> <li>3. Restart the server. If the Pwr rail B error has been recorded in the system event log again, (trained technician only) replace the system board (see “Removing the system board” on page 281 and “Replacing the system board” on page 284).</li> <li>4. Reinstall the DIMM one at a time, restarting the server each time. If the Pwr rail B error has been recorded in the system event log again, the DIMM that you just reinstalled is defective. Replace the defective component.</li> </ol>
The Pwr rail C error has been recorded in the system event log.	<ol style="list-style-type: none"> <li>1. Disconnect the server power cords.</li> <li>2. (Trained technician only) remove microprocessor 2 if Pwr rail C error has been recorded in the system event log.</li> <li>3. Restart the server. If the Pwr rail C error has been recorded in the system event log again, (trained technician only) replace the system board (see “Removing the system board” on page 281 and “Replacing the system board” on page 284).</li> <li>4. Reinstall the Processor; then, restarting the server. If the Pwr rail C error has been recorded in the system event log again, the Processor that you just reinstalled is defective. Replace the defective component. <ul style="list-style-type: none"> <li>• (Trained technician only) Microprocessor 2 (see “Removing a microprocessor and heat sink” on page 265 and “Replacing a microprocessor and heat sink” on page 270).</li> </ul> </li> </ol>



- Follow the suggested actions in the order in which they are listed in the Action column until the problem is solved.
- If an action step is preceded by “(Trained technician only),” that step must be performed only by a trained technician.
- Go to the support website at <http://www.lenovo.com/support> to check for technical information, hints, tips, and new device drivers or to submit a request for information.

Symptom	Action
<p>The Pwr rail D error has been recorded in the system event log.</p>	<ol style="list-style-type: none"> <li>1. Disconnect the server power cords.</li> <li>2. Remove DIMMs 13 through 24 if Pwr rail D error has been recorded in the system event log.</li> <li>3. Restart the server. If the Pwr rail D error has been recorded in the system event log again, (trained technician only) replace the system board (see “Removing the system board” on page 281 and “Replacing the system board” on page 284).</li> <li>4. Reinstall the DIMM one at a time, restarting the server each time. If the Pwr rail B error has been recorded in the system event log again, the DIMM that you just reinstalled is defective. Replace the defective component.</li> </ol>
<p>The Pwr rail E error has been recorded in the system event log.</p>	<ol style="list-style-type: none"> <li>1. Disconnect the server power cords.</li> <li>2. Remove the following components if the Pwr rail E error has been recorded in the system event log: <ul style="list-style-type: none"> <li>• Optional DVD drive (if one is installed)</li> <li>• Hard disk drives at backplane assembly 1 and/or backplane assembly 2</li> <li>• Hard disk drive backplane assembly 1 and/or backplane assembly 2</li> <li>• LCD monitor connected to front VGA port (if one is present)</li> <li>• Optional adapter (if one is present) installed in riser-card assembly 2</li> <li>• Riser-card assembly 2</li> </ul> </li> <li>3. Restart the server. If the Pwr rail E error has been recorded in the system event log again, (trained technician only) replace the system board (see “Removing the system board” on page 281 and “Replacing the system board” on page 284).</li> <li>4. Reinstall the components one at a time, in the order shown, restarting the server each time. If the Pwr rail E error has been recorded in the system event log again, the component that you just reinstalled is defective. Replace the defective component. <ul style="list-style-type: none"> <li>• Riser-card assembly 2 (See “Removing a riser-card assembly” on page 180 and “Replacing a riser-card assembly” on page 181).</li> <li>• Optional adapter (if one is present) installed in riser-card assembly 2 (See “Removing an adapter” on page 185 and “Replacing an adapter” on page 189).</li> <li>• LCD monitor connected to front VGA port (if one is present)</li> <li>• Hard disk drive backplane assembly 1 and/or backplane assembly 2</li> <li>• Hard disk drives at backplane assembly 1 and/or backplane assembly 2</li> <li>• Optional DVD drive, if one is present (see “Removing an optical drive” on page 161 and “Replacing an optical drive” on page 162).</li> </ul> </li> </ol>

- Follow the suggested actions in the order in which they are listed in the Action column until the problem is solved.
- If an action step is preceded by “(Trained technician only),” that step must be performed only by a trained technician.
- Go to the support website at <http://www.lenovo.com/support> to check for technical information, hints, tips, and new device drivers or to submit a request for information.

Symptom	Action
<p>The Pwr rail F error has been recorded in the system event log.</p>	<ol style="list-style-type: none"> <li>1. Disconnect the server power cords.</li> <li>2. Remove the following components if the Pwr rail F error has been recorded in the system event log: <ul style="list-style-type: none"> <li>• Hard disk drives at backplane assembly 3</li> <li>• Hard disk drive backplane assembly 3</li> <li>• Rear Hard disk drives</li> <li>• Rear two Hard-disk-drive kit</li> <li>• Optional adapter (if one is present) installed in riser-card assembly 1</li> <li>• Riser-card assembly 1</li> <li>• PCIe Solid state drives</li> <li>• PCIe Solid state drive backplane assembly</li> <li>• USB devices</li> <li>• SD adapter</li> <li>• LCD monitor connected to rear VGA port (if one is present)</li> </ul> </li> <li>3. Restart the server. If the Pwr rail F error has been recorded in the system event log again, (trained technician only) replace the system board (see “Removing the system board” on page 281 and “Replacing the system board” on page 284).</li> <li>4. Reinstall the components one at a time, in the order shown, restarting the server each time. If the Pwr rail F error has been recorded in the system event log again, the component that you just reinstalled is defective. Replace the defective component. <ul style="list-style-type: none"> <li>• LCD monitor connected to rear VGA port (if one is present)</li> <li>• SD adapter</li> <li>• USB devices</li> <li>• PCIe Solid state drive backplane assembly</li> <li>• PCIe Solid state drives</li> <li>• Riser-card assembly 1 (See “Removing a riser-card assembly” on page 180 and “Replacing a riser-card assembly” on page 181.</li> <li>• Optional adapter (if one is present) installed in riser-card assembly 1 (See “Removing an adapter” on page 185 and “Replacing an adapter” on page 189.</li> <li>• Rear two Hard-disk-drive kit</li> <li>• Rear Hard disk drives</li> <li>• Hard disk drive backplane assembly 3</li> <li>• Hard disk drives at backplane assembly 3</li> </ul> </li> </ol>
<p>The Pwr rail G error has been recorded in the system event log.</p>	<ol style="list-style-type: none"> <li>1. Disconnect the server power cords.</li> <li>2. Remove the following components if the Pwr rail G error has been recorded in the system event log:</li> </ol>

- Follow the suggested actions in the order in which they are listed in the Action column until the problem is solved.
- If an action step is preceded by “(Trained technician only),” that step must be performed only by a trained technician.
- Go to the support website at <http://www.lenovo.com/support> to check for technical information, hints, tips, and new device drivers or to submit a request for information.

Symptom	Action
	<ul style="list-style-type: none"> <li>• Raid Card in Raid slot</li> <li>• Optional adapter (if one is present) in PCIe slot 4</li> <li>• Optional adapter (if one is present) in PCIe slot 5</li> <li>• Optional adapter (if one is present) installed in riser-card assembly 1</li> <li>• Riser-card assembly 1</li> <li>• Optional adapter (if one is present) installed in riser-card assembly 2 (or Rear Hard disk Drives in Rear two Hard-disk-drive kit on Riser 2)</li> <li>• Riser-card assembly 2 (or Rear two Hard-disk-drive kit on Riser 2)</li> <li>• Microprocessor 2 <ul style="list-style-type: none"> <li>– (Trained technician only) Microprocessor 2 (See “Removing a microprocessor and heat sink” on page 265 and “Replacing a microprocessor and heat sink” on page 270).</li> </ul> </li> </ul> <p>3. Restart the server. If the Pwr rail G error has been recorded in the system event log again, (trained technician only) replace the system board (see “Removing the system board” on page 281 and “Replacing the system board” on page 284).</p> <p>4. Reinstall the components one at a time, in the order shown, restarting the server each time. If the Pwr rail G error has been recorded in the system event log again, the component that you just reinstalled is defective. Replace the defective component.</p> <ul style="list-style-type: none"> <li>• Microprocessor 2 <ul style="list-style-type: none"> <li>– (Trained technician only) Microprocessor 2 (See “Removing a microprocessor and heat sink” on page 265 and “Replacing a microprocessor and heat sink” on page 270).</li> </ul> </li> <li>• Riser-card assembly 2 (See “Removing a riser-card assembly” on page 180 and “Replacing a riser-card assembly” on page 181) or Rear two Hard-disk-drive kit on Riser 2.</li> <li>• Optional adapter (if one is present) installed in riser-card assembly 2 (See “Removing an adapter” on page 185 and “Replacing an adapter” on page 189) or Rear Hard disk Drives in Rear two Hard-disk-drive kit on Riser 2.</li> <li>• Riser-card assembly 1 (See “Removing a riser-card assembly” on page 180 and “Replacing a riser-card assembly” on page 181).</li> <li>• Optional adapter (if one is present) installed in riser-card assembly 1 (See “Removing an adapter” on page 185 and “Replacing an adapter” on page 189).</li> <li>• Optional adapter (if one is present) in PCIe slot 5</li> <li>• Optional adapter (if one is present) in PCIe slot 4</li> <li>• Raid Card in Raid slot</li> </ul> <p>5. (Trained technician only) remove all components</p> <p>6. (Trained technician only) replace the system board (see “Removing the system board” on page 281 and “Replacing the system board” on page 284).</p>

- Follow the suggested actions in the order in which they are listed in the Action column until the problem is solved.
- If an action step is preceded by “(Trained technician only),” that step must be performed only by a trained technician.
- Go to the support website at <http://www.lenovo.com/support> to check for technical information, hints, tips, and new device drivers or to submit a request for information.

Symptom	Action
	<p>7. Reinstall the Microprocessor 1; then, restarting the server. If the Pwr rail G error has been recorded in the system event log again, the Processor that you just reinstalled is defective. Replace the defective Processor.</p> <ul style="list-style-type: none"> <li>• (Trained technician only) Microprocessor 1 (See “Removing a microprocessor and heat sink” on page 265 and “Replacing a microprocessor and heat sink” on page 270).</li> </ul>
<p>The Pwr rail H error has been recorded in the system event log.</p>	<ol style="list-style-type: none"> <li>1. Disconnect the server power cords.</li> <li>2. Remove the following components if the Pwr rail H error has been recorded in the system event log: <ul style="list-style-type: none"> <li>• Hard disk drives at backplane assembly 3</li> <li>• Hard disk drive backplane assembly 3</li> <li>• PCIe Solid state drives</li> <li>• PCIe Solid state drive backplane assembly</li> </ul> </li> <li>3. Restart the server. If the Pwr rail H error has been recorded in the system event log again, (trained technician only) replace the system board (see “Removing the system board” on page 281 and “Replacing the system board” on page 284).</li> <li>4. Reinstall the components one at a time, in the order shown, restarting the server each time. If the Pwr rail H error has been recorded in the system event log again, the component that you just reinstalled is defective. Replace the defective component. <ul style="list-style-type: none"> <li>• Hard disk drive backplane assembly 3</li> <li>• Hard disk drives at backplane assembly 3</li> <li>• PCIe Solid state drive backplane assembly</li> <li>• PCIe Solid state drives</li> </ul> </li> </ol>
<p>The Pwr rail I error has been recorded in the system event log.</p>	<ol style="list-style-type: none"> <li>1. Disconnect the server power cords.</li> <li>2. Remove the following components if the Pwr rail I error has been recorded in the system event log: <ul style="list-style-type: none"> <li>• Hard disk drives at backplane assembly 1 and/or backplane assembly 2</li> <li>• Hard disk drive backplane assembly 1 and/or backplane assembly 2</li> </ul> </li> <li>3. Restart the server. If the Pwr rail I error has been recorded in the system event log again, (trained technician only) replace the system board (see “Removing the system board” on page 281 and “Replacing the system board” on page 284).</li> <li>4. Reinstall the components one at a time, in the order shown, restarting the server each time. If the Pwr rail I error has been recorded in the system event log again, the component that you just reinstalled is defective. Replace the defective component. <ul style="list-style-type: none"> <li>• Hard disk drive backplane assembly 1 and/or backplane assembly 2</li> <li>• Hard disk drives at backplane assembly 1 and/or backplane assembly 2</li> </ul> </li> </ol>

- Follow the suggested actions in the order in which they are listed in the Action column until the problem is solved.
- If an action step is preceded by “(Trained technician only),” that step must be performed only by a trained technician.
- Go to the support website at <http://www.lenovo.com/support> to check for technical information, hints, tips, and new device drivers or to submit a request for information.

Symptom	Action
<p>The Pwr rail J error has been recorded in the system event log.</p>	<ol style="list-style-type: none"> <li>1. Disconnect the server power cords.</li> <li>2. Remove Fans 1 through 6 if Pwr rail J error has been recorded in the system event log.</li> <li>3. Restart the server. If the Pwr rail J error has been recorded in the system event log again, (trained technician only) replace the system board (see “Removing the system board” on page 281 and “Replacing the system board” on page 284).</li> <li>4. Reinstall the Fans one at a time, restarting the server each time. If the Pwr rail J error has been recorded in the system event log again, the Fan that you just reinstalled is defective. Replace the defective component.</li> </ol>
<p>The Pwr rail K error has been recorded in the system event log.</p>	<ol style="list-style-type: none"> <li>1. Disconnect the server power cords.</li> <li>2. Remove the following components if the Pwr rail K error has been recorded in the system event log: <ul style="list-style-type: none"> <li>• Optional adapter (if one is present) installed in riser-card assembly 1 (or Rear Hard disk Drives in Rear two Hard-disk-drive kit on Riser 1)</li> <li>• Riser-card assembly 1 (or Rear two Hard-disk-drivekit on Riser 1)</li> <li>• Optional adapter (if one is present) installed in PCIe slot 4</li> <li>• Optional adapter (if one is present) installed in PCIe slot 5</li> <li>• Raid Card in Raid slot</li> </ul> </li> <li>3. Restart the server. If the Pwr rail H error has been recorded in the system event log again, (trained technician only) replace the system board (see “Removing the system board” on page 281 and “Replacing the system board” on page 284).</li> <li>4. Reinstall the components one at a time, in the order shown, restarting the server each time. If the Pwr rail K error has been recorded in the system event log again, the component that you just reinstalled is defective. Replace the defective component. <ul style="list-style-type: none"> <li>• Raid Card in Raid slot</li> <li>• Optional adapter (if one is present) installed in PCIe slot 5</li> <li>• Optional adapter (if one is present) installed in PCIe slot 4</li> <li>• Riser-card assembly 1 (or Rear two Hard-disk-drivekit on Riser 1)</li> <li>• Optional adapter (if one is present) installed in riser-card assembly 1 (or Rear Hard disk Drives in Rear two Hard-disk-drive kit on Riser 1)</li> </ul> </li> </ol>

- Follow the suggested actions in the order in which they are listed in the Action column until the problem is solved.
- If an action step is preceded by “(Trained technician only),” that step must be performed only by a trained technician.
- Go to the support website at <http://www.lenovo.com/support> to check for technical information, hints, tips, and new device drivers or to submit a request for information.

Symptom	Action
<p>The Pwr rail L error has been recorded in the system event log.</p>	<ol style="list-style-type: none"> <li>1. Disconnect the server power cords.</li> <li>2. Remove the following components if the Pwr rail L error has been recorded in the system event log: <ul style="list-style-type: none"> <li>• Optional PCI adaptor power cable-correlated PCI adaptor</li> <li>• PCI Riser Card Assembly where the optional PCI adaptor power cable-correlated PCI adaptor is installed <ul style="list-style-type: none"> <li>– Optional PCI adaptor power cable (if one is present)</li> </ul> </li> </ul> </li> <li>3. Restart the server. If the Pwr rail L error has been recorded in the system event log again, (trained technician only) replace the system board (see “Removing the system board” on page 281 and “Replacing the system board” on page 284).</li> <li>4. Reinstall the component one at a time, in the order shown, restarting the server. If the Pwr rail L error has been recorded in the system event log again, the component that you just reinstalled is defective. Replace the defective component. <ul style="list-style-type: none"> <li>• Optional PCI adaptor power cable (if one is present)</li> <li>• PCI Riser Card Assembly where the optional PCI adaptor power cable-correlated PCI adaptor is installed</li> <li>• Optional PCI adaptor power cable-correlated PCI adaptor</li> </ul> </li> </ol>
<p>The Pwr rail M error has been recorded in the system event log.</p>	<ol style="list-style-type: none"> <li>1. Disconnect the server power cords.</li> <li>2. Remove the following components if the Pwr rail M error has been recorded in the system event log: <ul style="list-style-type: none"> <li>• Optional PCI adaptor power cable-correlated PCI adaptor</li> <li>• PCI Riser Card Assembly where the optional PCI adaptor power cable-correlated PCI adaptor is installed</li> <li>• Optional PCI adaptor power cable (if one is present)</li> </ul> </li> <li>3. Restart the server. If the Pwr rail M error has been recorded in the system event log again, (trained technician only) replace the system board (see “Removing the system board” on page 281 and “Replacing the system board” on page 284).</li> <li>4. Reinstall the components one at a time, in the order shown, restarting the server each time. If the Pwr rail M error has been recorded in the system event log again, the component that you just reinstalled is defective. Replace the defective component. <ul style="list-style-type: none"> <li>• Optional PCI adaptor power cable (if one is present)</li> <li>• PCI Riser Card Assembly where the optional PCI adaptor power cable-correlated PCI adaptor is installed</li> <li>• Optional PCI adaptor power cable-correlated PCI adaptor</li> </ul> </li> </ol>

- Follow the suggested actions in the order in which they are listed in the Action column until the problem is solved.
- If an action step is preceded by “(Trained technician only),” that step must be performed only by a trained technician.
- Go to the support website at <http://www.lenovo.com/support> to check for technical information, hints, tips, and new device drivers or to submit a request for information.

Symptom	Action
The server does not turn off.	<ol style="list-style-type: none"> <li>1. Determine whether you are using an Advanced Configuration and Power Interface (ACPI) or a non-ACPI operating system. If you are using a non-ACPI operating system, complete the following steps:               <ol style="list-style-type: none"> <li>a. Press Ctrl+Alt+Delete.</li> <li>b. Turn off the server by pressing the power-control button and hold it down for 5 seconds.</li> <li>c. Restart the server.</li> <li>d. If the server fails POST and the power-control button does not work, disconnect the power cord for 20 seconds; then, reconnect the power cord and restart the server.</li> </ol> </li> <li>2. If the problem remains or if you are using an ACPI-aware operating system, suspect the system board.</li> </ol>
The server unexpectedly shuts down, and the LEDs on the operator information panel are not lit.	See “Solving undetermined problems” on page 105.

## Serial-device problems

Use the troubleshooting tables to find solutions to problems that have identifiable symptoms.

<ul style="list-style-type: none"> <li>• Follow the suggested actions in the order in which they are listed in the Action column until the problem is solved.</li> <li>• If an action step is preceded by “(Trained technician only),” that step must be performed only by a trained technician.</li> <li>• Go to the support website at <a href="http://www.lenovo.com/support">http://www.lenovo.com/support</a> to check for technical information, hints, tips, and new device drivers or to submit a request for information.</li> </ul>	
Symptom	Action
The number of serial ports that are identified by the operating system is less than the number of installed serial ports.	<ol style="list-style-type: none"> <li>1. Make sure that: <ul style="list-style-type: none"> <li>• Each port is assigned a unique address in the Setup Utility and none of the serial ports is disabled.</li> <li>• The serial-port adapter (if one is present) is seated correctly.</li> </ul> </li> <li>2. Reseat the serial port adapter.</li> <li>3. Replace the serial port adapter.</li> </ol>
A serial device does not work.	<ol style="list-style-type: none"> <li>1. Make sure that: <ul style="list-style-type: none"> <li>• The device is compatible with the server.</li> <li>• The serial port is enabled and is assigned a unique address.</li> <li>• The device is connected to the correct connector (see “System-board internal connectors” on page 28).</li> </ul> </li> <li>2. Reseat the following components: <ol style="list-style-type: none"> <li>a. Failing serial device</li> <li>b. Serial cable</li> </ol> </li> <li>3. Replace the components listed in 2 on page 100 one at a time, in the order shown, restarting the server each time.</li> <li>4. (Trained technician only) Replace the system board.</li> </ol>

## ServerGuide problems

Use the troubleshooting tables to find solutions to problems that have identifiable symptoms.

<ul style="list-style-type: none"> <li>• Follow the suggested actions in the order in which they are listed in the Action column until the problem is solved.</li> <li>• If an action step is preceded by “(Trained technician only),” that step must be performed only by a trained technician.</li> <li>• Go to the support website at <a href="http://www.lenovo.com/support">http://www.lenovo.com/support</a> to check for technical information, hints, tips, and new device drivers or to submit a request for information.</li> </ul>	
Symptom	Action
The <i>ServerGuide Setup and Installation</i> CD will not start.	<ol style="list-style-type: none"> <li>1. Make sure that the server supports the ServerGuide program and has a startable (bootable) CD or DVD drive.</li> <li>2. If the startup (boot) sequence settings have been changed, make sure that the CD or DVD drive is first in the startup sequence.</li> <li>3. If more than one CD or DVD drive is installed, make sure that only one drive is set as the primary drive. Start the CD from the primary drive.</li> </ol>
The MegaRAID Storage Manager program cannot view all installed drives, or the operating system cannot be installed.	<ol style="list-style-type: none"> <li>1. Make sure that the hard disk drive is connected correctly.</li> <li>2. Make sure that the SAS/SATA hard disk drive cables are securely connected.</li> </ol>



<ul style="list-style-type: none"> <li>• Follow the suggested actions in the order in which they are listed in the Action column until the problem is solved.</li> <li>• If an action step is preceded by “(Trained technician only),” that step must be performed only by a trained technician.</li> <li>• Go to the support website at <a href="http://www.lenovo.com/support">http://www.lenovo.com/support</a> to check for technical information, hints, tips, and new device drivers or to submit a request for information.</li> </ul>	
Symptom	Action
The operating-system installation program continuously loops.	Make more space available on the hard disk.
The ServerGuide program will not start the operating-system CD.	Make sure that the operating-system CD is supported by the ServerGuide program. For a list of supported operating-system versions, go to <a href="http://www.ibm.com/support/entry/portal/docdisplay?indocid=SERV-GUIDE">http://www.ibm.com/support/entry/portal/docdisplay?indocid=SERV-GUIDE</a> , click the link for your ServerGuide version, and scroll down to the list of supported Microsoft Windows operating systems.
The operating system cannot be installed; the option is not available.	Make sure that the server supports the operating system. If it does, either no logical drive is defined (SCSI RAID servers), or the ServerGuide System Partition is not present. Run the ServerGuide program and make sure that setup is complete.

## Software problems

<ul style="list-style-type: none"> <li>• Follow the suggested actions in the order in which they are listed in the Action column until the problem is solved.</li> <li>• If an action step is preceded by “(Trained technician only),” that step must be performed only by a trained technician.</li> <li>• Go to the support website at <a href="http://www.lenovo.com/support">http://www.lenovo.com/support</a> to check for technical information, hints, tips, and new device drivers or to submit a request for information.</li> </ul>	
Symptom	Action
You suspect a software problem.	<ol style="list-style-type: none"> <li>1. To determine whether the problem is caused by the software, make sure that: <ul style="list-style-type: none"> <li>• The server has the minimum memory that is needed to use the software. For memory requirements, see the information that comes with the software. If you have just installed an adapter or memory, the server might have a memory-address conflict.</li> <li>• The software is designed to operate on the server.</li> <li>• Other software works on the server.</li> <li>• The software works on another server.</li> </ul> </li> <li>2. If you received any error messages when using the software, see the information that comes with the software for a description of the messages and suggested solutions to the problem.</li> <li>3. Contact the software vendor.</li> </ol>

## USB connector problems

Use the troubleshooting tables to find solutions to problems that have identifiable symptoms.

- Follow the suggested actions in the order in which they are listed in the Action column until the problem is solved.
- If an action step is preceded by “(Trained technician only),” that step must be performed only by a trained technician.
- Go to the support website at <http://www.lenovo.com/support> to check for technical information, hints, tips, and new device drivers or to submit a request for information.

Symptom	Action
A USB device does not work.	<ol style="list-style-type: none"> <li>1. Make sure that: <ul style="list-style-type: none"> <li>• The correct USB device driver is installed.</li> <li>• The operating system supports USB devices.</li> </ul> </li> <li>2. Make sure that the USB configuration options are set correctly in the Setup Utility (see “Using the Setup Utility” on page 47 for more information).</li> <li>3. If you are using a USB hub, disconnect the USB device from the hub and connect it directly to the server.</li> </ol>

## Video problems

Use the troubleshooting tables to find solutions to problems that have identifiable symptoms.

See “Monitor and video problems” on page 86.

---

## Solving power problems

Power problems can be difficult to solve. For example, a short circuit can exist anywhere on any of the power distribution buses. Usually, a short circuit will cause the power subsystem to shut down because of an overcurrent condition.

To diagnose a power problem, use the following general procedure:

- Step 1. Turn off the server and disconnect all power cords.
- Step 2. Check for loose cables in the power subsystem. Also check for short circuits, for example, if a loose screw is causing a short circuit on a circuit board.
- Step 3. Check the lit LEDs on the light path diagnostics panel.
- Step 4. If the check log LED on the light path diagnostics panel is lit, check the IMM event log for faulty Pwr rail and complete the following steps. Table 7 “Components associated with power rail errors” on page 103 identifies the components that are associated with each Pwr rail and the order in which to troubleshoot the components.
  - a. Disconnect the cables and power cords to all internal and external devices (see “Internal cable routing and connectors” on page 131). Leave the power-supply cords connected.
  - b. For Pwr rail A error, complete the following steps:
    1. (Trained technician only) Replace the system board.
    2. (Trained technician only) Replace the microprocessor.
  - c. For other rail errors (Pwr rail A error, see step ), remove each component that is associated with the faulty Pwr rail, one at a time, in the sequence indicated in Table 7 “Components associated with power rail errors” on page 103, restarting the server each time, until the cause of the overcurrent condition is identified.

Table 7. Components associated with power rail errors

Pwr rail error in the IMM event log	Components
Pwr rail A error	<ul style="list-style-type: none"> <li>• Microprocessor 1</li> </ul>
Pwr rail B error	<ul style="list-style-type: none"> <li>• DIMMs 1 through 12</li> </ul>
Pwr rail C error	<ul style="list-style-type: none"> <li>• Microprocessor 2</li> </ul>
Pwr rail D error	<ul style="list-style-type: none"> <li>• DIMMs 13 through 24</li> </ul>
Pwr rail E error	<ul style="list-style-type: none"> <li>• Optional DVD drive (if one is installed)</li> <li>• Hard disk drives at backplane assembly 1 and/or backplane assembly 2</li> <li>• Hard disk drive backplane assembly 1 and/or backplane assembly 2</li> <li>• LCD monitor connected to front VGA port (if one is present)</li> <li>• Optional adapter (if one is present) installed in riser-card assembly 2</li> <li>• Riser-card assembly 2</li> </ul>
Pwr rail F error	<ul style="list-style-type: none"> <li>• Hard disk drives at backplane assembly 3</li> <li>• Hard disk drive backplane assembly 3</li> <li>• Rear Hard disk drives</li> <li>• Rear two Hard-disk-drive kit</li> <li>• Optional adapter (if one is present) installed in riser-card assembly 1</li> <li>• Riser-card assembly 1</li> <li>• PCIe Solid state drives</li> <li>• PCIe Solid state drive backplane assembly</li> <li>• USB devices</li> <li>• SD adapter</li> <li>• LCD monitor connected to rear VGA port (if one is present)</li> </ul>
Pwr rail G error	<ul style="list-style-type: none"> <li>• Raid Card in Raid slot</li> <li>• Optional adapter (if one is present) in PCIe slot 4</li> <li>• Optional adapter (if one is present) in PCIe slot 5</li> <li>• Optional adapter (if one is present) installed in riser-card assembly 1</li> <li>• Riser-card assembly 1</li> <li>• Optional adapter (if one is present) installed in riser-card assembly 2 (or Rear Hard disk Drives in Rear two Hard-disk-drive kit on Riser 2)</li> <li>• Riser-card assembly 2 (or Rear two Hard-disk-drive kit on Riser 2)</li> <li>• Microprocessor 2</li> <li>• Microprocessor 1</li> </ul>

Table 7. Components associated with power rail errors (continued)

Pwr rail error in the IMM event log	Components
Pwr rail H error	<ul style="list-style-type: none"> <li>• Hard disk drives at backplane assembly 3</li> <li>• Hard disk drive backplane assembly 3</li> <li>• PCIe Solid state drives</li> <li>• PCIe Solid state drive backplane assembly</li> </ul>
Pwr rail I error	<ul style="list-style-type: none"> <li>• Hard disk drives at backplane assembly 1 and/or backplane assembly 2</li> <li>• Hard disk drive backplane assembly 1 and/or backplane assembly 2</li> </ul>
Pwr rail J error	<ul style="list-style-type: none"> <li>• Fans 1 through 6</li> </ul>
Pwr rail K error	<ul style="list-style-type: none"> <li>• Optional adapter (if one is present) installed in riser-card assembly 1 (or Rear Hard disk Drives in Rear two Hard-disk-drive kit on Riser 1)</li> <li>• Riser-card assembly 1 (or Rear two Hard-disk-drive kit on Riser 1)</li> <li>• Optional adapter (if one is present) installed in PCIe slot 4</li> <li>• Optional adapter (if one is present) installed in PCIe slot 5</li> <li>• Raid Card in Raid slot</li> </ul>
Pwr rail L error	<ul style="list-style-type: none"> <li>• Optional PCI adaptor power cable-correlated PCI adaptor</li> <li>• PCI Riser Card Assembly where the optional PCI adaptor power cable-correlated PCI adaptor is installed</li> <li>• Optional PCI adaptor power cable (if one is present)</li> </ul>
Pwr rail M error	<ul style="list-style-type: none"> <li>• Optional PCI adaptor power cable-correlated PCI adaptor</li> <li>• PCI Riser Card Assembly where the optional PCI adaptor power cable-correlated PCI adaptor is installed</li> <li>• Optional PCI adaptor power cable (if one is present)</li> </ul>

d. Replace the identified component.

Step 5. Remove the adapters and disconnect the cables and power cords to all internal and external devices until the server is at the minimum configuration that is required for the server to start (see “Power-supply LEDs” on page 69 for the minimum configuration).

Step 6. Reconnect all ac power cords and turn on the server. If the server starts successfully, reseal the adapters and devices one at a time until the problem is isolated.

If the server does not start from the minimum configuration, see “Power-supply LEDs” on page 69 to replace the components in the minimum configuration one at a time until the problem is isolated.

---

## Solving Ethernet controller problems

The method that you use to test the Ethernet controller depends on which operating system you are using. See the operating-system documentation for information about Ethernet controllers, and see the Ethernet controller device-driver readme file.

Try the following procedures:

- Step 1. Make sure that the correct device drivers, which come with the server are installed and that they are at the latest level.
- Step 2. Make sure that the Ethernet cable is installed correctly.
  - The cable must be securely attached at all connections. If the cable is attached but the problem remains, try a different cable.
  - If you set the Ethernet controller to operate at 100 Mbps, you must use Category 5 cabling.
  - If you directly connect two servers (without a hub), or if you are not using a hub with X ports, use a crossover cable. To determine whether a hub has an X port, check the port label. If the label contains an X, the hub has an X port.
- Step 3. Determine whether the hub supports auto-negotiation. If it does not, try configuring the integrated Ethernet controller manually to match the speed and duplex mode of the hub.
- Step 4. Check the Ethernet controller LEDs on the rear panel of the server. These LEDs indicate whether there is a problem with the connector, cable, or hub.
  - The Ethernet link status LED is lit when the Ethernet controller receives a link pulse from the hub. If the LED is off, there might be a defective connector or cable or a problem with the hub.
  - The Ethernet transmit/receive activity LED is lit when the Ethernet controller sends or receives data over the Ethernet network. If the Ethernet transmit/receive activity is off, make sure that the hub and network are operating and that the correct device drivers are installed.
- Step 5. Check the LAN activity LED on the rear of the server. The LAN activity LED is lit when data is active on the Ethernet network. If the LAN activity LED is off, make sure that the hub and network are operating and that the correct device drivers are installed.
- Step 6. Check for operating-system-specific causes of the problem.
- Step 7. Make sure that the device drivers on the client and server are using the same protocol.

If the Ethernet controller still cannot connect to the network but the hardware appears to be working, the network administrator must investigate other possible causes of the error.

---

## Solving undetermined problems

If Dynamic System Analysis (DSA) did not diagnose the failure or if the server is inoperative, use the information in this section.

If you suspect that a software problem is causing failures (continuous or intermittent), see “Software problems” on page 101.

Corrupted data in CMOS memory or corrupted UEFI firmware can cause undetermined problems. To reset the CMOS data, use the CMOS clear jumper (J11) to clear the CMOS memory and override the power-on password; see Table 2 “System board jumpers” on page 31 for more information. If you suspect that the UEFI firmware is corrupted, see “Recovering the server firmware (UEFI update failure)” on page 107.

If the power supplies are working correctly, complete the following steps:

- Step 1. Turn off the server.
- Step 2. Make sure that the server is cabled correctly.
- Step 3. Remove or disconnect the following devices, one at a time, until you find the failure. Turn on the server and reconfigure it each time.
  - Any external devices.
  - Surge-suppressor device (on the server).
  - Printer, mouse, and non-Lenovo devices.
  - Each adapter.
  - Hard disk drives.
  - Memory modules. The minimum configuration requirement is 4 GB DIMM in DIMM slot 1.
- Step 4. Turn on the server.

If the problem is solved when you remove an adapter from the server but the problem recurs when you reinstall the same adapter, suspect the adapter; if the problem recurs when you replace the adapter with a different one, suspect the riser card.

If you suspect a networking problem and the server passes all the system tests, suspect a network cabling problem that is external to the server.

---

## Problem determination tips

Because of the variety of hardware and software combinations that can encounter, use the following information to assist you in problem determination. If possible, have this information available when requesting assistance from Lenovo.

The model name and serial number are located on the ID label on the front of the server as shown in the following illustration.

**Note:** The illustrations in this document might differ slightly from your hardware.

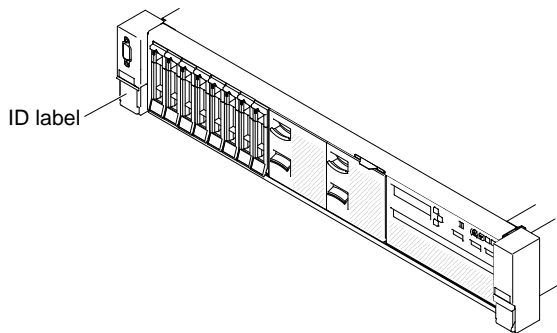

Figure 47. ID label

- Machine type and model
- Microprocessor or hard disk drive upgrades
- Failure symptom
  - Does the server fail the diagnostic tests?
  - What occurs? When? Where?
  - Does the failure occur on a single server or on multiple servers?
  - Is the failure repeatable?
  - Has this configuration ever worked?

- What changes, if any, were made before the configuration failed?
- Is this the original reported failure?
- Diagnostic program type and version level
- Hardware configuration (print screen of the system summary)
- UEFI firmware level
- IMM firmware level
- Operating system software

You can solve some problems by comparing the configuration and software setups between working and nonworking servers. When you compare servers to each other for diagnostic purposes, consider them identical only if all the following factors are exactly the same in all the servers:

- Machine type and model
- UEFI firmware level
- IMM firmware level
- Adapters and attachments, in the same locations
- Address jumpers, terminators, and cabling
- Software versions and levels
- Diagnostic program type and version level
- Configuration option settings
- Operating-system control-file setup

See Appendix D “Getting help and technical assistance” on page 1149 for information about calling Lenovo for service.

---

## Recovering the server firmware (UEFI update failure)

Use this information to recover the server firmware.

**Important:** Some cluster solutions require specific code levels or coordinated code updates. If the device is part of a cluster solution, verify that the latest level of code is supported for the cluster solution before you update the code.

If the server firmware has become corrupted, such as from a power failure during an update, you can recover the server firmware in the following way:

- **In-band method:** Recover server firmware, using either the boot block jumper (Automated Boot Recovery) and a server Firmware Update Package Service Pack.
- **Out-of-band method:** Use the IMM web interface to update the firmware, using the latest server firmware update package.

**Note:** You can obtain a server update package from one of the following sources:

- Download the server firmware update from the World Wide Web.
- Contact your service representative.

To download the server firmware update package from the World Wide Web, go to <http://www.lenovo.com/support>.

The flash memory of the server consists of a primary bank and a back up bank. You must maintain a bootable UEFI firmware image in the back up bank. If the server firmware in the primary bank becomes corrupted, you can either manually boot the back up bank with the UEFI boot backup jumper (J15), or in the case of image corruption, this will occur automatically with the Automated Boot Recovery function.

## In-band manual recovery method

This section details the in-band manual recovery method.

To recover the server firmware and restore the server operation to the primary bank, complete the following steps:

- Step 1. Read the safety information that begins on “Safety” on page v and “Installation guidelines” on page 287.
- Step 2. Turn off the server, and disconnect all power cords and external cables.
- Step 3. Remove the cover (see “Removing the top cover” on page 144).
- Step 4. Locate the UEFI boot backup jumper (J15) on the system board.

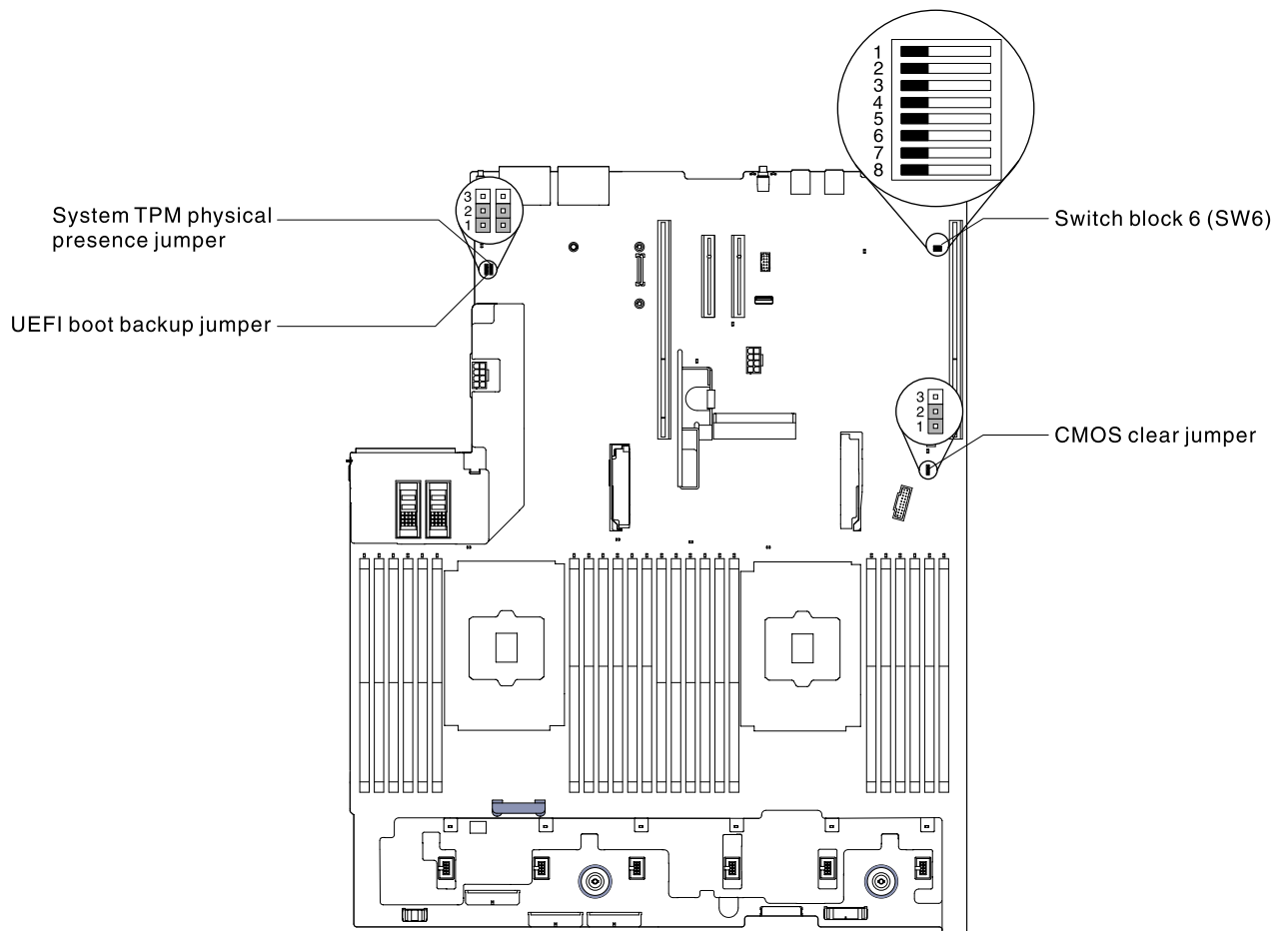

Figure 48. UEFI boot backup jumper (J15) location

- Step 5. Move the UEFI boot backup jumper (J15) from pins 1 and 2 to pins 2 and 3 to enable the UEFI recovery mode.
- Step 6. Reinstall the server cover; then, reconnect all power cords.



- Step 7. Restart the server. The system begins the power-on self-test (POST).
- Step 8. Boot the server to an operating system that is supported by the firmware update package that you downloaded.
- Step 9. Perform the firmware update by following the instructions that are in the firmware update package readme file.
- Step 10. Turn off the server and disconnect all power cords and external cables, and then remove the cover (see “Removing the top cover” on page 144).
- Step 11. Move the UEFI boot backup jumper (J15) from pins 2 and 3 back to the primary position (pins 1 and 2).
- Step 12. Reinstall the cover (see “Replacing the top cover” on page 146).
- Step 13. Reconnect the power cord and any cables that you removed.
- Step 14. Restart the server. The system begins the power-on self-test (POST). If this does not recover the primary bank, continue with the following steps.
- Step 15. Remove the top cover (see “Removing the top cover” on page 144).
- Step 16. Reset the CMOS by removing the coin-cell battery (also called CMOS battery). See “Removing the coin-cell battery (also called CMOS battery)” on page 247.
- Step 17. Leave the coin-cell battery out of the server for approximately 5 to 15 minutes.
- Step 18. Reinstall the coin-cell battery (see “Replacing the coin-cell battery (also called CMOS battery)” on page 250).
- Step 19. Reinstall the top cover (see “Replacing the top cover” on page 146).
- Step 20. Reconnect the power cord and any cables that you removed.
- Step 21. Restart the server. The system begins the power-on self-test (POST).
- Step 22. If these recovery efforts fail, contact your service representative for support.

## In-band automated boot recovery method

This section details the in-band automated boot recovery method.

**Note:** Use this method if the BOARD LED on the light path diagnostics panel is lit and there is a log entry or Booting Backup Image is displayed on the firmware splash screen; otherwise, use the in-band manual recovery method.

- Step 1. Boot the server to an operating system that is supported by the firmware update package that you downloaded.
- Step 2. Perform the firmware update by following the instructions that are in the firmware update package readme file.
- Step 3. Restart the server.
- Step 4. At the firmware splash screen, press F3 when prompted to restore to the primary bank. The server boots from the primary bank.

## Out-of-band method

See the IMM2 documentation (*Integrated Management Module II User's Guide*) at [http://publib.boulder.ibm.com/infocenter/systemx/documentation/topic/com.lenovo.sysx.imm2.doc/printable\\_doc.html](http://publib.boulder.ibm.com/infocenter/systemx/documentation/topic/com.lenovo.sysx.imm2.doc/printable_doc.html).

---

## Automated boot recovery (ABR)

Use this information for Automated boot recovery (ABR).

While the server is starting, if the integrated management module II detects problems with the server firmware in the primary bank, the server automatically switches to the backup firmware bank and gives you the opportunity to recover the firmware in the primary bank. For instructions for recovering the UEFI firmware, see “Recovering the server firmware (UEFI update failure)” on page 107. After you have recovered the firmware in the primary bank, complete the following steps:

Step 1. Restart the server.

Step 2. When the prompt Press F3 to restore to primary is displayed, press F3 to start the server from the primary bank.

---

## Nx-boot failure

Use this information for Nx-boot failure.

Configuration changes, such as added devices or adapter firmware updates, and firmware or application code problems can cause the server to fail POST (the power-on self-test). If this occurs, the server responds in either of the following ways:

- The server restarts automatically and attempts POST again.
- The server hangs, and you must manually restart the server for the server to attempt POST again.

After a specified number of consecutive attempts (automatic or manual), the Nx-boot failure feature causes the server to revert to the default UEFI configuration and start the Setup Utility so that you can make the necessary corrections to the configuration and restart the server. If the server is unable to successfully complete POST with the default configuration, there might be a problem with the system board.

To specify the number of consecutive restart attempts that will trigger the Nx-boot failure feature, in the Setup Utility, click **System Settings** → **Recovery** → **POST Attempts** → **POST Attempts Limit**. The available options are 3, 6, 9, and 255 (disable Nx-boot failure).

---

## Chapter 4. Parts listing, Lenovo Storage DX8200

The parts listing of Lenovo Storage DX8200

The following replaceable components are available for the Lenovo Storage DX8200 server, except as specified otherwise in “Replaceable server components” on page 111. For an updated parts listing, go to <http://www.lenovo.com/support>.

---

### Replaceable server components

The replaceable server components for Lenovo Storage DX8200

Replaceable components consist of structural parts, consumable parts, and field replaceable units (FRUs):

- **Structural parts:** Purchase and replacement of structural parts (components, such as chassis assembly, top cover, and bezel) is your responsibility. If Lenovo acquires or installs a structural component at your request, you will be charged for the service. See “Structural parts and consumable parts” on page 127 for the list of structural parts.
- **Consumable parts:** Purchase and replacement of consumable parts (components, such as fan cage and blank fan filler) is your responsibility. If Lenovo acquires or installs a consumable component at your request, you will be charged for the service. See “Structural parts and consumable parts” on page 127 for the list of consumable parts.
- **Tier 1 customer replaceable unit (CRU):** Replacement of Tier 1 CRUs is your responsibility. If Lenovo installs a Tier 1 CRU at your request, you will be charged for the installation.
- **Tier 2 CRU:** You may install a Tier 2 CRU yourself or request Lenovo to install it, at no additional charge, under the type of warranty service that is designated for your server.

For information about the terms of the warranty and getting service and assistance, see the *Warranty Information* document that comes with the server. For more information about getting service and assistance, see Appendix D “Getting help and technical assistance” on page 1149.

Visit <http://www.lenovo.com/serverproven/> for the latest options supporting plan.

The following illustration shows the major components in the server. The illustrations in this document might differ slightly from your hardware. For a list of structural parts and consumable parts, see “Structural parts and consumable parts” on page 127.

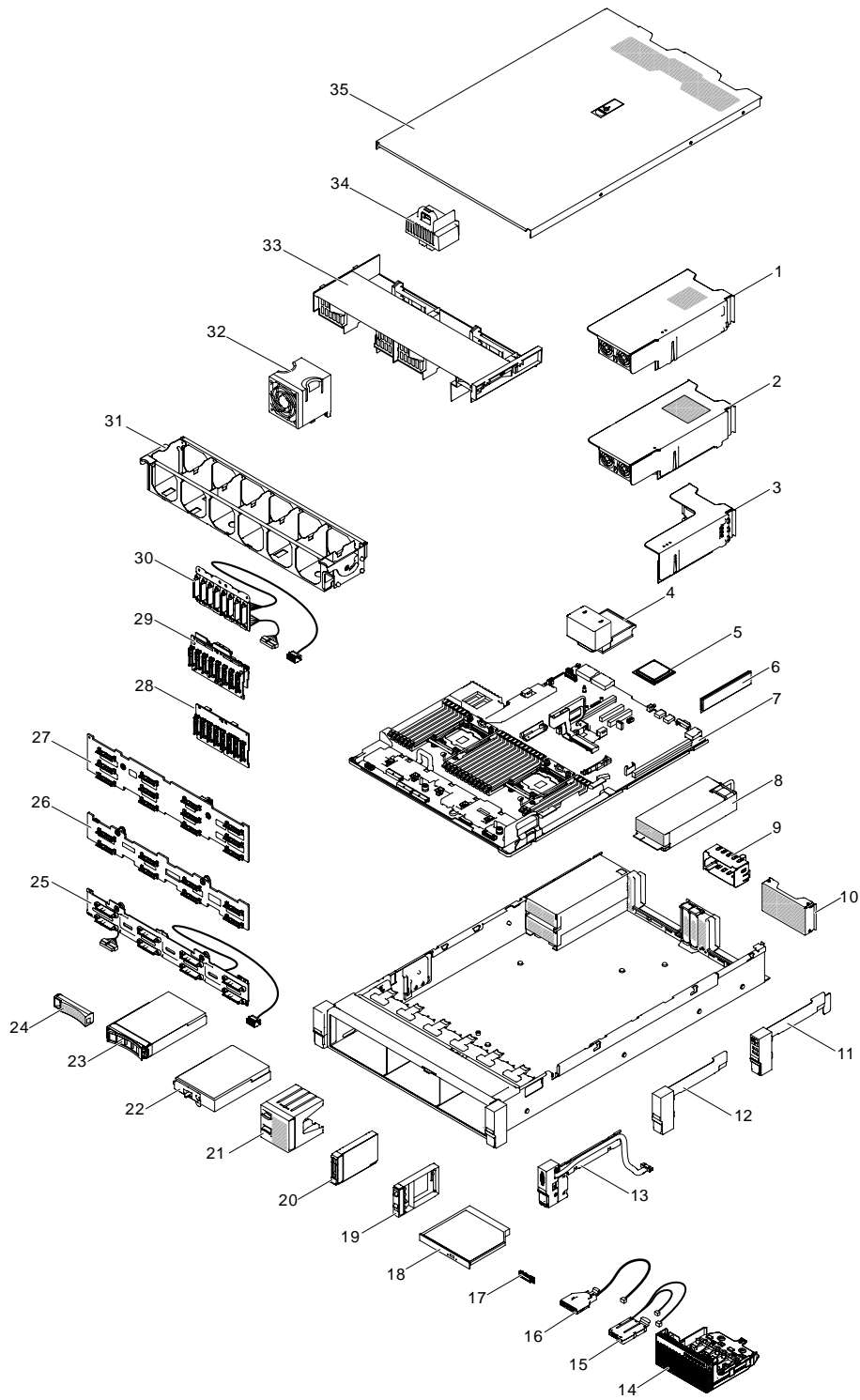

Figure 49. Server components

The following table lists the part numbers for Tier 1 and Tier 2 CRUs.

Table 8. CRU parts listing, Type 5120, 5128, 5133, 5135, 5136, and 5139

Index	Description	CRU part number (Tier 1)	CRU part number (Tier 2)
1	2.5-inch rear two hard-disk-drive kit	00AL953	
2	3.5-inch rear two hard-disk-drive kit	00AL954	
3	PCIe Riser (2 x8 PCIe + 1 x8 ML2 Slots)	00FK630	
3	PCIe Riser (1 x16 PCIe + 1 x8 ML2 Slots)	00FK631	
3	PCIe Riser (1 x16 PCIe + 1 x8 PCIe )	00FK628	
3	PCIe Riser (3 x8 PCIe )	00FK629	
4	Heat sink, value		00KA517
4	Heat sink, performance		00KA518
5	Microprocessor, Intel Xeon Processor E5-2698 v4, 2.2 GHz, 50MB, Cache 2400 MHz, 135W (20-core) Addl Intel Xeon Processor E5-2698 v4, 2.2 GHz, 50MB, Cache 2400 MHz, 135W (20-core)		00MW771
5	Microprocessor, Intel Xeon Processor E5-2695 v4, 2.1GHz, 45MB, Cache 2400MHz, 120W (18-core) Addl Intel Xeon Processor E5-2695 v4, 2.1GHz, 45MB, Cache 2400MHz, 120W (18-core)		00MW772
5	Microprocessor, Intel Xeon Processor E5-2683 v4, 2.1GHz, 40MB, Cache 2400MHz, 120W (16-core) Addl Intel Xeon Processor E5-2683 v4, 2.1GHz, 40MB, Cache 2400MHz, 120W (16-core)		00MW774
5	Microprocessor, Intel Xeon Processor E5-2667 v4, 3.2GHz, 25MB, Cache 2400MHz, 135W (8-core) Addl Intel Xeon Processor E5-2667 v4, 3.2GHz, 25MB, Cache 2400MHz, 135W (8-core)		00MW776
5	Microprocessor, Intel Xeon Processor E5-2650L v4, 1.7GHz, 35MB, Cache 2400MHz, 65W (14-core) Addl Intel Xeon Processor E5-2650L v4, 1.7GHz, 35MB, Cache 2400MHz, 65W (14-core)		00MW777
5	Microprocessor, Intel Xeon Processor E5-2643 v4, 3.4GHz, 20MB, Cache 2400MHz, 135W (6-core) Addl Intel Xeon Processor E5-2643 v4, 3.4GHz, 20MB, Cache 2400MHz, 135W (6-core)		00MW778
5	Microprocessor, Intel Xeon Processor E5-2637 v4, 3.5GHz, 15MB, Cache 2400MHz, 135W (4-core) Addl Intel Xeon Processor E5-2637 v4, 3.5GHz, 15MB, Cache 2400MHz, 135W (4-core)		00MW779
5	Microprocessor, Intel Xeon Processor E5-2630L v4, 1.8GHz, 25MB, Cache 2133MHz, 55W (10-core) Addl Intel Xeon Processor E5-2630L v4, 1.8GHz, 25MB, Cache 2133MHz, 55W (10-core)		00MW780
5	Microprocessor, Intel Xeon Processor E5-2623 v4, 2.6GHz, 10MB, Cache 2133MHz, 85W (4-core) Addl Intel Xeon Processor E5-2623 v4, 2.6GHz, 10MB, Cache 2133MHz, 85W (4-core)		00MW781

Table 8. CRU parts listing, Type 5120, 5128, 5133, 5135, 5136, and 5139 (continued)

Index	Description	CRU part number (Tier 1)	CRU part number (Tier 2)
5	Microprocessor, Intel Xeon Processor E5-2609 v4, 1.7GHz, 20MB, Cache 1866MHz, 85W (8-core)		00MW782
5	Microprocessor, Intel Xeon Processor E5-2603 v4, 1.7GHz, 15MB, Cache 1866MHz, 85W (6-core)		00MW783
5	Microprocessor, Intel Xeon Processor E5-2699 v4, 2.2GHz, 55MB, Cache 2400MHz, 145W (22-core) Addl Intel Xeon Processor E5-2699 v4, 2.2GHz, 55MB, Cache 2400MHz, 145W (22-core)		00YD967
5	Microprocessor, Intel Xeon Processor E5-2697 v4, 2.3GHz, 45MB, Cache 2400MHz, 145W (18-core)		00YD968
5	Microprocessor, Intel Xeon Processor E5-2690 v4, 2.6GHz, 35MB, Cache 2400MHz, 135W (14-core)		00YD969
5	Microprocessor, Intel Xeon Processor E5-2680 v4, 2.4GHz, 35MB, Cache 2400MHz, 120W (14-core)		00YD970
5	Microprocessor, Intel Xeon Processor E5-2660 v4, 2.0GHz, 35MB, Cache 2400MHz, 105W (14-core)		00YD971
5	Microprocessor, Intel Xeon Processor E5-2650 v4, 2.2GHz, 30MB, Cache 2400MHz, 105W (12-core)		00YD972
5	Microprocessor, Intel Xeon Processor E5-2640 v4, 2.4GHz, 25MB, Cache 2133MHz, 90W (10-core)		00YD973
5	Microprocessor, Intel Xeon Processor E5-2630 v4, 2.2GHz, 25MB, Cache 2133MHz, 85W (10-core)		00YD974
5	Microprocessor, Intel Xeon Processor E5-2620 v4, 2.1GHz, 20MB, Cache 2133MHz, 85W (8-core)		00YD975
5	Microprocessor, Intel Xeon Processor E5-2608L v4, 1.6GHz, 20MB, Cache 1866MHz, 50W (8-core) Addl Intel Xeon Processor E5-2608L v4, 1.6GHz, 20MB, Cache 1866MHz, 50W (8-core)		00YE946
5	Microprocessor, Intel Xeon Processor E5-2618L v4, 2.2GHz, 25MB, Cache, 2133MHz, 75W (10-core) Addl Intel Xeon Processor E5-2618L v4, 2.2GHz, 25MB, Cache, 2133MHz, 75W (10-core)		00YE947
5	Microprocessor, Intel Xeon Processor E5-2628L v4, 1.9GHz, 30MB, Cache 2133MHz, 75W (12-core) Addl Intel Xeon Processor E5-2628L v4, 1.9GHz, 30MB, Cache 2133MHz, 75W (12-core)		00YE948
5	Microprocessor, Intel Xeon Processor E5-2648L v4, 1.8GHz, 35MB, Cache 2400MHz, 75W (14-core) Addl Intel Xeon Processor E5-2648L v4, 1.8GHz, 35MB, Cache 2400MHz, 75W (14-core)		00YE949
5	Microprocessor, Intel Xeon Processor E5-2658 v4, 2.3GHz, 35MB, Cache 2400MHz, 105W (14-core) Addl Intel Xeon Processor E5-2658 v4, 2.3GHz, 35MB, Cache 2400MHz, 105W (14-core)		00YE950

Table 8. CRU parts listing, Type 5120, 5128, 5133, 5135, 5136, and 5139 (continued)

Index	Description	CRU part number (Tier 1)	CRU part number (Tier 2)
6	Memory module, 8GB TruDDR4 (1Rx4, 1.2V), PC4-19200 CL17 2400MHz LP RDIMM	46W0823	
6	Memory module, 8GB TruDDR4 (2Rx8, 1.2V), PC4-19200 CL17 2400MHz LP RDIMM	46W0827	
6	Memory module, 16GB TruDDR4 (2Rx4, 1.2V), PC4-19200 CL17 2400MHz LP RDIMM	46W0831	
6	Memory module, 32GB TruDDR4 (2Rx4, 1.2V), PC4-19200 CL17 2400MHz LP RDIMM	46W0835	
6	Memory module, 64GB TruDDR4 (4Rx4, 1.2V), PC4-17000 PC4 2400MHz LP LRDIMM	46W0843	
7	System board		00MW385
8	550W High Efficiency Platinum AC Power Supply	94Y8137	
8	550W High Efficiency Platinum AC Power Supply	94Y8139	
8	550W High Efficiency Platinum AC Power Supply	94Y8173	
8	550W High Efficiency Platinum AC Power Supply	00YL551	
8	550W High Efficiency Platinum AC Power Supply	00YL553	
8	750W High Efficiency Platinum AC Power Supply	94Y8142	
8	750W High Efficiency Platinum AC Power Supply	94Y8144	
8	750W High Efficiency Platinum AC Power Supply	00YL555	
8	750W High Efficiency Platinum AC Power Supply	00YL557	
8	750W High Efficiency Titanium AC Power Supply	00YL559	
8	750W High Efficiency Titanium AC Power Supply (200-240V)	94Y8152	
8	750W High Efficiency Titanium AC Power Supply (200-240V)	94Y8150	
8	750W High Efficiency Titanium AC Power Supply (200-240V)	00YL561	
8	900W High Efficiency Platinum AC Power Supply	94Y8146	
8	900W High Efficiency Platinum AC Power Supply	94Y8148	
8	900W High Efficiency -48 V DC Power Supply	94Y8167	
8	1300W High Efficiency Titanium AC Power Supply (200-240V)	94Y8177	
8	1500W High Efficiency Platinum AC Power Supply	94Y8181	
9	Power supply filler panel	94Y7610	
10	Riser cage filler	00AL950	
11	Right functional EIA assembly	00MV813	
12	Right EIA blank	00KF411	
13	Left video EIA assembly	00MV815	
14	Front control panel assembly	00YE420	

Table 8. CRU parts listing, Type 5120, 5128, 5133, 5135, 5136, and 5139 (continued)

Index	Description	CRU part number (Tier 1)	CRU part number (Tier 2)
15	Operator information panel assembly	00KF492	
16	Front USB assembly	00YE411	
17	LCD panel	00D0464	
18	9.5 mm Ultra-Slim SATA DVD-ROM	00FL352	
18	9.5 mm Ultra-Slim SATA multi-burner	00FL353	
19	Hard disk drive filler assembly, GEN 3	00FW856	
20	Hard disk drive, 2.5-inch G3 simple-swap, near-line SATA, 7.2 K, 6 Gbps, 500 GB	00NA602	
20	Hard disk drive, 2.5-inch G3 simple-swap, near-line SATA, 7.2 K, 6 Gbps, 1 TB	00NA627	
20	Hard disk drive, 2.5-inch G3 simple-swap, near-line SATA, 7.2 K, 6 Gbps, 512e, 2 TB	00NA537	
20	Hard disk drive, 2.5-inch G3 hot-swap, SAS, 10 K, 12 Gbps, 300 GB	00WG686	
20	Hard disk drive, 2.5-inch G3 hot-swap, SAS, 10 K, 6 Gbps, 300 GB	00AJ097	
20	Hard disk drive, 2.5-inch G3 hot-swap, SAS, 15 K, 12 Gbps, 300 GB	00WG661	
20	Hard disk drive, 2.5-inch G3 hot-swap, SAS, 15 K, 6 Gbps, 300 GB	00AJ082	
20	Hard disk drive, 2.5-inch G3 hot-swap, SAS, 10K, 6 Gbps, 600 GB	00AJ092	
20	Hard disk drive, 2.5-inch G3 hot-swap, SAS, 10 K, 12 Gbps, 600 GB	00WG691	
20	Hard disk drive, 2.5-inch G3 hot-swap, SAS, 15 K, 12 Gbps, 600 GB	00WG666	
20	Hard disk drive, 2.5-inch G3 hot-swap, SAS, 15 K, 6 Gbps, 600 GB	00AJ127	
20	Hard disk drive, 2.5-inch G3 hot-swap, SAS, 10 K, 12 Gbps, 900 GB	00WG696	
20	Hard disk drive, 2.5-inch G3 hot-swap, SAS, 10 K, 6 Gbps, 900 GB	00AJ072	
20	Hard disk drive, 2.5-inch G3 hot-swap, SAS, 10 K, 12 Gbps, 1.2 TB	00WG701	
20	Hard disk drive, 2.5-inch G3 hot-swap, SAS, 10 K, 6 Gbps, 1.2 TB	00AJ147	
20	Hard disk drive, 2.5-inch G3 hot-swap, near-line SAS, 7.2 K, 6 Gbps, 500 GB	00AJ122	
20	Hard disk drive, 2.5-inch G3 hot-swap, near-line SAS, 7.2 K, 6 Gbps, 1 TB	00AJ087	
20	Hard disk drive, 2.5-inch G3 hot-swap, near-line SAS, 7.2 K, 12 Gbps, 1 TB	00NA492	



Table 8. CRU parts listing, Type 5120, 5128, 5133, 5135, 5136, and 5139 (continued)

Index	Description	CRU part number (Tier 1)	CRU part number (Tier 2)
20	Hard disk drive, 2.5-inch G3 hot-swap, near-line SAS, 7.2 K, 12 Gbps, 2 TB	00NA497	
20	Hard disk drive, 2.5-inch G3 hot-swap, near-line SATA, 7.2 K, 6 Gbps, 500 GB	00AJ137	
20	Hard disk drive, 2.5-inch G3 hot-swap, near-line SATA, 7.2 K, 6 Gbps, 1 TB	00AJ142	
20	Hard disk drive, 2.5-inch G3 hot-swap, near-line SATA, 7.2 K, 6 Gbps, 512e, 2 TB	00NA527	
20	Hard disk drive, 2.5-inch G3 hot-swap, SAS, 15 K, 12 Gbps, 512e, 300 GB	00NA222	
20	Hard disk drive, 2.5-inch G3 hot-swap, SAS, 10 K, 12 Gbps, 512e, 600 GB	00NA242	
20	Hard disk drive, 2.5-inch G3 hot-swap, SAS, 10 K, 12 Gbps, 512e, 900 GB	00NA252	
20	Hard disk drive, 2.5-inch G3 hot-swap, SAS, 10 K, 12 Gbps, 512e, 1.2 TB	00NA262	
20	Hard disk drive, 2.5-inch G3 hot-swap, SAS, 10 K, 12 Gbps, 512e, 1.8 TB	00NA272	
21	2.5-inch 4-drive filler panel	00KF417	
22	Hard disk drive, 3.5-inch G2 simple-swap, near-line SATA, 7.2 K, 6 Gbps, 500 GB	81Y9803	
22	Hard disk drive, 3.5-inch simple-swap, near-line SATA, 7.2 K, 6 Gbps, 1 TB	81Y9807	
22	Hard disk drive, 3.5-inch G2 simple-swap, near-line SATA, 7.2 K, 6 Gbps, 2 TB	81Y9811	
23	Hard disk drive, 3.5-inch G2 hot-swap, SAS, 15K, 12 Gbps, 300 GB	00WG676	
23	Hard disk drive, 3.5-inch G2 hot-swap, SAS, 15K, 12 Gbps, 600 GB	00WG681	
23	Hard disk drive, 3.5-inch G2 hot-swap, near-line SATA, 7.2 K, 6 Gbps, 512e, 2 TB	00FN114	
23	Hard disk drive, 3.5-inch G2 hot-swap, near-line SATA, 7.2 K, 6 Gbps, 512e, 4 TB	00FN144	
23	Hard disk drive, 3.5-inch G2 hot-swap, near-line SATA, 7.2 K, 6 Gbps, 512e, 6 TB	00FN174	
23	Hard disk drive, 3.5-inch G2 hot-swap, near-line SAS, 7.2 K, 12 Gbps, 512e, 2 TB	00FN189	
23	Hard disk drive, 3.5-inch G2 hot-swap, near-line SAS, 7.2 K, 12 Gbps, 512e, 4 TB	00FN209	
23	Hard disk drive, 3.5-inch G2 hot-swap, near-line SAS, 7.2 K, 12 Gbps, 512e, 6 TB	00FN229	

Table 8. CRU parts listing, Type 5120, 5128, 5133, 5135, 5136, and 5139 (continued)

Index	Description	CRU part number (Tier 1)	CRU part number (Tier 2)
23	Hard disk drive, 3.5-inch G2 hot-swap, near-line SATA, 7.2K, 6 Gbps, 4 TB	49Y6003	
23	Hard disk drive, 3.5-inch G2 hot-swap, near-line SAS, 7.2K, 6 Gbps, 1 TB	90Y8568	
23	Hard disk drive, 3.5-inch G2 hot-swap, near-line SAS, 7.2K, 6 Gbps, 2 TB	90Y8573	
23	Hard disk drive, 3.5-inch G2 hot-swap, near-line SAS, 7.2K, 6 Gbps, 3 TB	90Y8578	
23	Hard disk drive, 3.5-inch G2 hot-swap, near-line SAS, 7.2K, 12 Gbps, 1 TB	00YL703	
23	Hard disk drive, 3.5-inch G2 hot-swap, near-line SAS, 7.2K, 12 Gbps, 2 TB	00YK001	
23	Hard disk drive, 3.5-inch G2 hot-swap, near-line SAS, 7.2K, 12 Gbps, 4 TB	00YK006	
23	Hard disk drive, 3.5-inch G2 hot-swap, near-line SATA, 7.2K, 6 Gbps, 500 GB	81Y9787	
23	Hard disk drive, 3.5-inch G2 hot-swap, near-line SATA, 7.2 K, 6 Gbps, 1 TB	81Y9791	
23	Hard disk drive, 3.5-inch G2 hot-swap, near-line SATA, 7.2 K, 6 Gbps, 2 TB	81Y9795	
23	Hard disk drive, 3.5-inch G2 hot-swap, near-line SATA, 7.2 K, 6 Gbps, 3 TB	81Y9799	
23	Hard disk drive, 3.5-inch G2 hot-swap, near-line SAS, 7.2 K, 12 Gbps, 512e, 8 TB	00WH122	
23	Hard disk drive, 3.5-inch G2 hot-swap, near-line SATA, 7.2 K, 6 Gbps, 512e, 8 TB	00WH127	
	Solid state drive, 2.5-inch MLC G3 hot-swap, SAS, Enterprise, 12 Gbps, 200 GB	00FN380	
	Solid state drive, 2.5-inch MLC G3 hot-swap, SAS, Enterprise, 12 Gbps, 400 GB	00FN390	
	Solid state drive, 2.5-inch MLC G3 hot-swap, SAS, Enterprise, 12 Gbps, 800 GB	00FN400	
	Solid state drive, 2.5-inch MLC G3 hot-swap, SAS, Enterprise, 12 Gbps, 1.6 TB	00FN410	
	Solid state drive, 2.5-inch MLC G3 hot-swap, SAS, Enterprise, 200 GB	00AJ208	
	Solid state drive, 2.5-inch MLC G3 hot-swap, SAS, Enterprise, 400 GB	00AJ213	
	Solid state drive, 2.5-inch MLC G3 hot-swap, SAS, Enterprise, 800 GB	00AJ218	
	Solid-state drive, 2.5-inch G3 hot-swap, SAS, Enterprise Mainstream, 12 Gbps, 400 GB	00YC461	

Table 8. CRU parts listing, Type 5120, 5128, 5133, 5135, 5136, and 5139 (continued)

Index	Description	CRU part number (Tier 1)	CRU part number (Tier 2)
	Solid-state drive, 2.5-inch G3 hot-swap, SAS, Enterprise Mainstream, 12 Gbps, 800 GB	00YC466	
	Solid-state drive, 2.5-inch G3 hot-swap, SAS, Enterprise Mainstream, 12 Gbps, 1.6 TB	00YC471	
	Solid-state drive, MLC G3 hot-swap, SAS, 6 Gbps, Enterprise Capacity, 3.84 TB	00NA672	
	Solid-state drive, 2.5-inch G3 hot-swap, SATA, M500DC, Enterprise Mainstream Plus, 480 GB	00NA689	
	Solid state drive, 2.5-inch MLC G3 hot-swap, SATA, Enterprise Value, 120 GB	00AJ396	
	Solid state drive, 2.5-inch MLC G3 hot-swap, SATA, Enterprise Value, 240 GB	00AJ401	
	Solid state drive, 2.5-inch MLC G3 hot-swap, SATA, Enterprise Value, 480 GB	00AJ406	
	Solid state drive, 2.5-inch MLC G3 hot-swap, SATA, Enterprise Value, 800 GB	00AJ411	
	Solid state drive, 2.5-inch MLC G3 hot-swap, SATA, S3700, 200 GB	00AJ157	
	Solid state drive, 2.5-inch MLC G3 hot-swap, SATA, S3700, 400 GB	00AJ162	
	Solid state drive, 2.5-inch MLC G3 hot-swap, SATA, S3700, 800 GB	00AJ167	
	Solid state drive, 2.5-inch MLC G3 hot-swap, SATA, Entry, 240 GB	00FN338	
	Solid state drive, 2.5-inch MLC G3 hot-swap, SATA, Entry, 480 GB	00FN343	
	Solid state drive, 2.5-inch MLC G3 hot-swap, SATA, Entry, 960 GB	00FN348	
	Solid state drive, 2.5-inch G3 hot-swap, SATA, Enterprise Value, S3500, 120 GB	00AJ172	
	Solid state drive, 2.5-inch G3 hot-swap, SATA, Enterprise Value, S3500, 240 GB	00AJ177	
	Solid state drive, 2.5-inch G3 hot-swap, SATA, Enterprise Value, S3500, 480 GB	00AJ182	
	Solid state drive, 2.5-inch G3 hot-swap, SATA, Enterprise Value, S3500, 800 GB	00AJ187	
	Solid state drive, 2.5-inch MLC G3 hot-swap, SATA, Enterprise Value, S3500, 1.6 TB	00FN279	
	Solid state drive, 2.5-inch G3 hot-swap, SATA, Enterprise Entry, S3510 series, 120 GB	00WG621	
	Solid state drive, 2.5-inch G3 hot-swap, SATA, Enterprise Entry, S3510 series, 240 GB	00WG626	

Table 8. CRU parts listing, Type 5120, 5128, 5133, 5135, 5136, and 5139 (continued)

Index	Description	CRU part number (Tier 1)	CRU part number (Tier 2)
	Solid state drive, 2.5-inch G3 hot-swap, SATA, Enterprise Entry, S3510 series, 480 GB	00WG631	
	Solid state drive, 2.5-inch G3 hot-swap, SATA, Enterprise Entry, S3510 series, 800 GB	00WG636	
	Solid state drive, 2.5-inch G3 hot-swap, SATA, Enterprise Entry, 120 GB	00YC386	
	Solid state drive, 2.5-inch G3 hot-swap, SATA, Enterprise Entry, 240 GB	00YC391	
	Solid state drive, 2.5-inch G3 hot-swap, SATA, Enterprise Entry, 480 GB	00YC396	
	Solid state drive, 2.5-inch G3 hot-swap, SATA, Enterprise Entry, 960 GB	00YC401	
	Solid state drive, 2.5-inch G3 hot-swap, SATA, Enterprise Performance, S3710, 200 GB	00YC321	
	Solid state drive, 2.5-inch G3 hot-swap, SATA, Enterprise Performance, S3710, 400 GB	00YC326	
	Solid state drive, 2.5-inch G3 hot-swap, SATA, Enterprise Performance, S3710, 800 GB	00YC331	
	Solid state drive, 3.5-inch MLC hot-swap, SATA, Enterprise Value, 120 GB	00AJ436	
	Solid state drive, 3.5-inch MLC hot-swap, SATA, Enterprise Value, 480 GB	00AJ446	
	Solid state drive, 3.5-inch MLC hot-swap, SATA, Enterprise, S3700, 400 GB	00AJ486	
	Solid state drive, 3.5-inch MLC hot-swap, SATA, Enterprise, S3700, 800 GB	00AJ491	
	Solid state drive, 3.5-inch MLC hot-swap, SATA, Entry, 960 GB	00FN363	
	Solid state drive, 3.5-inch hot-swap, SATA, Enterprise Entry, 960 GB	00YC421	
	Solid state drive, 3.5-inch hot-swap, SATA, Enterprise Performance, S3710, 400 GB	00YC341	
	Solid state drive, 3.5-inch hot-swap, SATA, Enterprise Performance, S3710, 800 GB	00YC346	
	Self-Encrypting drive, 2.5-inch G3 hot-swap, SAS, 10 K, 12 Gbps, 512e, 600 GB	00NA292	
	Self-Encrypting drive, 2.5-inch G3 hot-swap, SAS, 10 K, 12 Gbps, 512e, 1.2 TB	00NA302	
	Self-Encrypting drive, 2.5-inch G3 hot-swap, SAS, 10 K, 12 Gbps, 300 GB	00WG706	
	Self-Encrypting drive, 2.5-inch G3 hot-swap, SAS, 10 K, 12 Gbps, 600 GB	00WG711	

Table 8. CRU parts listing, Type 5120, 5128, 5133, 5135, 5136, and 5139 (continued)

Index	Description	CRU part number (Tier 1)	CRU part number (Tier 2)
	Self-Encrypting drive, 2.5-inch G3 hot-swap, SAS, 10 K, 12 Gbps, 900 GB	00WG716	
	Self-Encrypting drive, 2.5-inch G3 hot-swap, SAS, 10 K, 12 Gbps, 1.2 TB	00WG721	
	PCIe solid-state drive, 2.5-inch G3 hot-swap, Enterprise Performance, NVMe, P3700, 400 GB	00YA819	
	PCIe solid-state drive, 2.5-inch G3 hot-swap, Enterprise Performance, NVMe, P3700, 800 GB	00YA822	
	PCIe solid-state drive, 2.5-inch G3 hot-swap, Enterprise Performance, NVMe, P3700, 1.6 TB	00YA825	
	PCIe solid-state drive, 2.5-inch G3 hot-swap, Enterprise Performance, NVMe, P3700, 2.0 TB	00YA828	
	PCIe solid state drive, 2.5-inch G3 hot-swap, Enterprise Value, NVMe, P3600, 400 GB	90Y3228	
	PCIe solid state drive, 2.5-inch G3 hot-swap, Enterprise Value, NVMe, P3600, 800 GB	90Y3231	
	PCIe solid state drive, 2.5-inch G3 hot-swap, Enterprise Value, NVMe, P3600, 1.6 TB	90Y3234	
	PCIe solid state drive, 2.5-inch G3 hot-swap, Enterprise Value, NVMe, P3600, 2.0 TB	90Y3237	
24	3.5-inch hot-swap HDD filler panel	69Y5364	
25	3.5-inch HDD simple-swap backplate (M5 to RAID)	00KA479	
26	3.5-inch HDD hot-swap backplane with 8 HDDs	00FJ751	
27	3.5-inch HDD hot-swap backplane with 12 HDDs	00FJ754	
28	2.5-inch HDD hot-swap backplane	00FJ756	
29	2.5-inch HDD hot-swap backplane (expander)	00AG941	
30	2.5-inch HDD simple-swap backplate (M5 to RAID)	00KA477	
32	Fan	00YE423	
33	Air baffle	00KF406	
34	Power paddle module	00FK636	
	3.5-inch simple-swap filler	69Y5368	
	Optical drive filler	00KF416	
	Emulex 8Gb FC single-port HBA	00JY847	
	Emulex 8Gb FC dual-port HBA	00JY848	
	Emulex 16Gb FC single-port HBA	00D8546	
	Emulex 16Gb FC single-port HBA	01CV833	
	Emulex 16Gb FC dual-port HBA	01CV843	
	Emulex 16Gb FC dual-port HBA	00JY849	

Table 8. CRU parts listing, Type 5120, 5128, 5133, 5135, 5136, and 5139 (continued)

Index	Description	CRU part number (Tier 1)	CRU part number (Tier 2)
	N2215 SAS/SATA HBA	47C8676	
	N2225 SAS/SATA HBA	00AE914	
	N2226 SAS/SATA HBA	00KH483	
	M5225 SAS/SATA controller	00AE939	
	ServeRAID M5210 SAS/SATA controller	46C9111	
	ServeRAID M1215 SAS/SATA controller	46C9115	
	QLogic 8Gb FC single-port HBA	00Y5628	
	QLogic 8Gb FC dual-port HBA	00Y5629	
	QLogic 16Gb FC single-port HBA	00Y3340	
	QLogic 16Gb FC single-port HBA	01CV753	
	QLogic 16Gb FC dual-port HBA	00Y3344	
	QLogic 16Gb FC dual-port HBA	01CV763	
	Solarflare SFN7122F 2x10GbE SFP+ Flareon Ultra	47C9980	
	Broadcom NetXtreme I Quad Port GbE Adapter	90Y9355	
	Broadcom NetXtreme I Dual Port GbE Adapter	90Y9373	
	Broadcom NetXtreme Dual Port 10GbE SFP+ Adapter	94Y5182	
	Broadcom NetXtreme II ML2 Dual Port 10GbE SFP+	94Y5231	
	Broadcom NetXtreme II ML2 Dual Port 10GbaseT	94Y5233	
	Intel Ethernet Dual Port Server Adapter I350-T2	00AG512	
	Intel Ethernet Quad Port Server Adapter I350-T4	00AG522	
	Intel I350-F1 1xGbE Fiber Adapter	00AG502	
	Intel I350-T4 ML2 Quad Port GbE Adapter	00JY932	
	Intel X520 Dual Port 10GbE SFP+ Adapter	49Y7962	
	Intel X540-T2 Dual Port 10G BaseT Adapter	49Y7972	
	Intel X540 ML2 Dual Port 10G baseT Adapter	00JY912	
	Intel X550-T2 Dual Port 10GBase-T Adapter	00MM862	
	Intel QLE7340 single-port 4X QDR IB x8 PCI-E 2.0 HCA	59Y1890	
	Intel X710 2x10GbE SFP+ Adapter	81Y3522	
	Intel X710 ML2 4x10GbE SFP+ Adapter	94Y5203	
	Intel X710-DA2 ML2 2x10GbE SFP+ Adapter	00JY942	
	Intel OPA 100 Series Single-port PCIe 3.0 x8 HFA	00WE025	
	Intel OPA 100 Series Single-port PCIe 3.0 x16 HFA	00WE029	
	Emulex VFA5 ML2 Dual Port 10GbE SFP+ Adapter	94Y5195	
	Emulex VFA5.2 ML2 Dual Port 10GbE SFP+ Adapter	00AG563	

Table 8. CRU parts listing, Type 5120, 5128, 5133, 5135, 5136, and 5139 (continued)

Index	Description	CRU part number (Tier 1)	CRU part number (Tier 2)
	Emulex VFA5.2 2x10 GbE SFP+ PCIe Adapter	00AG573	
	Emulex VFA5.2 2x10 GbE SFP+ PCIe Adapter and FCoE/iSCSI SW	00AG583	
	Emulex VFA5 2x10 GbE SFP+ PCIe Adapter	00JY823	
	Emulex VFA5 2x10 GbE SFP+ Adapter and FCoE/iSCSI SW	00JY833	
	Mellanox ConnectX-3 40GbE / FDR IB VPI Adapter	00D9552	
	Mellanox ConnectX-3 10 GbE Adapter	00D9692	
	Mellanox ConnectX-3 Pro ML2 2x40GbE/FDR VPI Adapter	00FP652	
	Mellanox ConnectX-3 EN Single-port SFP+ 10GbE Adapter	00AE049	
	Mellanox Connect-IB FDR IB Single-port PCIe 3.0 x16 HCA	00D1775	
	Mellanox Connect-IB FDR IB Single-port PCIe 3.0 x8 HCA	00D1890	
	Mellanox QSFP to SFP+ Adapter	00D9678	
	Mellanox ConnectX-4 EDR IB VPI Single-port x16 PCIe 3.0 HCA	00KH926	
	Mellanox ConnectX-4 EDR IB VPI Dual-port x16 PCIe 3.0 HCA	00KH930	
	Mellanox ConnectX-3 VPI Single-port QSFP FDR IB HCA	00W0039	
	Mellanox Connect-IB Dual-port QSFP FDR IB PCI-E 3.0 x16 HCA	46W0573	
	Mellanox ConnectX-3 EN Dual-port QSFP+ 40GbE Adapter	95Y3461	
	Mellanox ConnectX-4 Lx 1x40GbE QSFP+ Adapter	00MM953	
	Mellanox ConnectX-4 2x100GbE/EDR IB QSFP28 VPI Adapter	00MM963	
	MLX 25G ML2 Adapter	00MN993	
	Chelsio T520-LL-CR Dual-port (SFP+) 10GbE PCI-E 3.0 Adapter	46W0611	
	Chelsio T540-CR Quad-port (SFP+) 10GbE PCI-E 3.0 Adapter	46W0617	
	Chelsio T580-LP-CR Dual-port (QSFP+) 40GbE PCI-E 3.0 Adapter	46W0622	
	Broadcom NetXtreme 2x10GbE BaseT Adapter	00E2714	
	Solarflare SFN5162F MR Dual Port 10GbE SFP+ Adapter	47C9955	
	Brocade 10Gb SFP+ SR optical transceiver	46C9297	
	Qlogic 10Gb SFP+ SR optical transceiver	42C1816	
	QSFP+ 40GBASE-SR4 transceiver	49Y7928	
	BNT SFP+ transceiver module assembly	46C3449	
	ServeRAID M5200 Series 1GB Cache/RAID 5 Upgrade	47C8657	

Table 8. CRU parts listing, Type 5120, 5128, 5133, 5135, 5136, and 5139 (continued)

Index	Description	CRU part number (Tier 1)	CRU part number (Tier 2)
	ServeRAID M5200 Series 1GB Flash/RAID 5 Upgrade	47C8661	
	ServeRAID M5200 Series 2GB Flash/RAID 5 Upgrade	47C8665	
	ServeRAID M5200 Series 4GB Flash/RAID 5 Upgrade	47C8669	
	Cable, Oculink, 830mm	00MU995	
	Cable, UM KVM Module VGA+SD Dual RJ45	00AK143	
	Cable, COM PORT	00KC965	
	Cable, FPC - PLANAR		00FK803
	Cable, SATA DVD for 2.5-inch models	00FK809	
	Cable, SATA DVD for 3.5-inch models	00FK853	
	Cable, SAS HD, 150 mm (vertical-vertical)	00KF717	
	Cable, SAS HD, 250 mm	00KF719	
	Cable, SAS HD, 350 mm (vertical-vertical)	00KF704	
	Cable, SAS HD 250 mm	00FK817	
	Cable, SAS HD 550 mm	00FK811	
	Cable, SAS HD 750 mm	00FK813	
	Cable, SAS HD 450/450 mm	00FK845	
	Cable, SAS HD 590/580 mm	00FK843	
	Cable, SAS HD 525/635 mm	00FK839	
	Cable, SAS HD 770/835 mm	00FK841	
	Cable, SAS HD 950/905 mm	00FK847	
	Cable, SAS HD 950/905 mm, R/A	00FK849	
	Cable, 0.6M HD mSAS to mSAS	00D2142	
	Cable, 1.5M HD mSAS to mSAS	00D2144	
	Cable, 3.0M HD mSAS to mSAS	00D2148	
	Cable, 6.0m HD mSAS to mSAS	44X3322	
	Cable, front HDD 80 mm	00KC582	
	Cable, front HDD 150 mm	00FK819	
	Cable, front HDD, 230 mm	00FK825	
	Cable, front HDD, 260 mm	00KF464	
	Cable, 3.5-inch front HDD, 16-pin	00KA541	
	Cable, GPU power converter, 2x3, 240 mm	00FK827	
	Cable, GPU power converter, 2x4, 240 mm	00FK829	
	Cable, GPU power converter, 6P/8P 240 mm	00FK831	
	Cable, USB conversion	39M2909	



Table 8. CRU parts listing, Type 5120, 5128, 5133, 5135, 5136, and 5139 (continued)

Index	Description	CRU part number (Tier 1)	CRU part number (Tier 2)
	Cable, external USB 3.0, 3 m	00MW395	
	Cable, internal USB, 1 m	44E8893	
	Cable, 425mm/925mm, super cap for ServRAID M5200 series flash	46C9793	
	Cable, USB CRUs	46M6475	
	Cable, GPU 6P/6P, 240mm	00KG970	
	Cable, 6 Gbps external mini-SAS, SFF-8088 to SFF-8088, 1 m	00YE299	
	Cable, 6 Gbps external mini-SAS, SFF-8088 to SFF-8088, 2 m	00YE300	
	Cable, 6 Gbps external mini-SAS, SFF-8088 to SFF-8088, 4 m	00YE301	
	Cable, 6 Gbps external mini-SAS, SFF-8088 to SFF-8088, 6 m	00YE302	
	Cable, 6 Gbps external mini-SAS, SFF-8644 to SFF-8088, 0.5 m	00YE303	
	Cable, 7 Gbps external mini-SAS, SFF-8644 to SFF-8088, 1 m	00YE304	
	Cable, 8 Gbps external mini-SAS, SFF-8644 to SFF-8088, 2 m	00YE305	
	Cable, 9 Gbps external mini-SAS, SFF-8644 to SFF-8088, 4 m	00YE306	
	Cable, 10 Gbps external mini-SAS, SFF-8644 to SFF-8088, 6 m	00YE307	
	Cable, 0.5m Intel OPA 100 Series Passive Copper QSFP28	00WE033	
	Cable, 0.75m Intel OPA Passive Copper QSFP28	00WE037	
	Cable, 1m Intel OPA 100 Series Passive Copper QSFP28	00WE041	
	Cable, 1.25m Intel OPA 100 Series Passive Copper QSFP28	00WE045	
	Cable, 1.5m Intel OPA 100 Series Passive Copper QSFP28	00WE049	
	Cable, 2m Intel OPA 100 Series Passive Copper QSFP28	00WE053	
	Cable, 3m Intel OPA 100 Series Passive Copper QSFP28	00WE057	
	Cable, 5m Intel OPA 100 Series Active Optical QSFP28	00WE061	
	Cable, 10m Intel OPA 100 Series Active Optical QSFP28	00WE065	
	Cable, 15m Intel OPA 100 Series Active Optical QSFP28	00WE069	
	Cable, 20m Intel OPA 100 Series Active Optical QSFP28	00WE073	
	Line cord, 2.8 m, 10A/100-250V, C13 to IEC 320-C14 rack power cable	39M5377	
	Line cord, 2.8 m, 13A/125-10A/250V, C13 to IEC 320-C14 rack power cable	39M5509	
	ServeRAID M5100/M5200 Series flash power module	00JY023	
	32 GB Enterprise Value USB Memory Key	00ML201	
	2 GB USB Memory Key	42D0545	

Table 8. CRU parts listing, Type 5120, 5128, 5133, 5135, 5136, and 5139 (continued)

Index	Description	CRU part number (Tier 1)	CRU part number (Tier 2)
	4 GB USB Memory Key	00WH143	
	3.0-volt battery	33F8354	
	RDX 3.0 internal tape drive	00MW717	
	RDX 3.0 external tape drive	00MW718	
	NVIDIA Grid K1 (actively cooled)	90Y2432	
	NVIDIA Grid K2 (actively cooled)	90Y2395	
	NVIDIA Tesla K40c	90Y2408	
	NVIDIA Tesla M60 GPU, PCIe (active)	90Y2472	
	NVIDIA Quadro M5000 GPU, PCIe (active)	90Y2488	
	Security bezel	00FK615	
	MISC KIT	00KF419	
	Slim slide kit	00KA592	
	Slide Gritstone	00MV990	
	Cable management arm (CMA)	00KA594	
	Label, chassis	00KF412	
	Labels, system service and FRU/CRU (2.5-inch)	00YE416	
	Labels, system service and FRU/CRU (3.5-inch)	00YE417	
	Gen-II Universal slides kit	00KA593	
	Air baffle (ML2)	00KG754	
	Intel Xeon Phi 3120A	90Y2403	
	Intel Xeon Phi 7120A	90Y2420	
	Flash Adapter, Enterprise Mainstream, io3, 1.25 TB	00YA801	
	Flash Adapter, Enterprise Mainstream, io3, 1.6 TB	00YA804	
	Flash Adapter, Enterprise Mainstream, io3, 3.2 TB	00YA807	
	Flash Adapter, Enterprise Mainstream, io3, 6.4 TB	00YA810	
	Flash Adapter, Enterprise Performance, NVMe, P3700, 1.6 TB	00YA813	
	Flash Adapter, Enterprise Performance, NVMe, P3700, 2 TB	00YA816	
	Flash Adapter, Enterprise Value, io3, 1250 GB	00AE985	
	Flash Adapter, Enterprise Value, io3, 1600 GB	00AE988	
	Flash Adapter, Enterprise Value, io3, 3200 GB	00AE991	
	Flash Adapter, Enterprise Value, io3, 6400 GB	00AE994	
	Flash Adapter, Enterprise, io3, 1000 GB	00AE997	
	Flash Adapter, Enterprise, io3, 1300 GB	00JY000	
	Flash Adapter, Enterprise, io3, 2600 GB	00JY003	

Table 8. CRU parts listing, Type 5120, 5128, 5133, 5135, 5136, and 5139 (continued)

Index	Description	CRU part number (Tier 1)	CRU part number (Tier 2)
	Flash Adapter, Enterprise, io3, 5200 GB	00JY006	
	Video adapter, NVIDIA Quadro K420	90Y2436	
	Video adapter, NVIDIA Quadro K620	90Y2440	
	Video adapter, NVIDIA Quadro K2200	90Y2444	
	Video adapter, NVIDIA Quadro K4200	90Y2448	
	Video adapter, NVIDIA Quadro K5200	90Y2452	
	Video adapter, NVIDIA Quadro K6000	90Y2371	
	Video adapter, NVIDIA Telsa K8 (actively cooled)	90Y2456	
	SD Media Adapter	00YK624	
	SD flash memory card	00ML701	
	NVMe PCIe SSD Extender Adapter	47C8304	
	NVMe Backplane	47C8333	
	EIA Nameplate	00MV897	
	DPI Universal 7 C13 PDU	39Y8914	
	Media cage bay with bezel (without LCD panel, front USB assembly, and operator information panel assembly)	00YE410	
	Media cage bay without bezel (with front USB assembly and operator information panel assembly)	00YJ759	
	Professional keyboard, USB, US English, 103P, RoHS v2	00AL883	
	Optical wheel mouse, USB, black	00MW370	
	Mounting screws, M3x3, RoHS	42C3933	
	Alcohol wipe		59P4739/ 00MP352

## Structural parts and consumable parts

Structural parts and consumable parts are not covered by the Statement of Limited Warranty. You can place an order on structural parts or consumable parts from the Lenovo retail store.

The following structural parts and consumable parts are available for purchase from the retail store.

Table 9. Structural parts, Type 5120, 5128, 5133, 5135, 5136, and 5139

In- dex	Description	Part number
	Chassis, 2.5-inch, 24 HDD model	00YE413
	Chassis, 3.5-inch, 8 HDD model	00YE414
	Chassis, 3.5-inch, 12 HDD model	00YE415

Table 9. Structural parts, Type 5120, 5128, 5133, 5135, 5136, and 5139 (continued)

In- dex	Description	Part number
35	Top cover, 2.5-inch model	00YL727
35	Top cover, 3.5-inch model	00YL728

Table 10. Consumable parts, Type 5120, 5128, 5133, 5135, 5136, and 5139

Index	Description	Part number
	Left EIA blank	00YE412
31	Fan cage	00YE421
	Blank fan filler	00YE422
	USB cover	00YJ761
	Thermal grease	41Y9292
	CPU installation/removal tool	00YJ766

To order a structural part or a consumable part, complete the following steps:

**Note:** Changes are made periodically to the website. The actual procedure might vary slightly from what is described in this document.

1. Go to <http://www.ibm.com>.
2. From the **Products** menu, select **Upgrades, accessories & parts**.
3. Click **Obtain maintenance parts**; then, follow the instructions to order the part from the retail store.

If you need help with your order, call the toll-free number that is listed on the retail parts page, or contact your local representative for assistance.

---

## Power cords

For your safety, a power cord with a grounded attachment plug is provided to use with this product. To avoid electrical shock, always use the power cord and plug with a properly grounded outlet.

Power cords used in the United States and Canada are listed by Underwriter's Laboratories (UL) and certified by the Canadian Standards Association (CSA).

For units intended to be operated at 115 volts: Use a UL-listed and CSA-certified cord set consisting of a minimum 16 AWG, Type SVT or SJT, three-conductor cord, a maximum of 15 feet in length and a parallel blade, grounding-type attachment plug rated 15 amperes, 125 volts.

For units intended to be operated at 230 volts (U.S. use): Use a UL-listed and CSA-certified cord set consisting of a minimum 18 AWG, Type SVT or SJT, three-conductor cord, a maximum of 15 feet in length and a tandem blade, grounding-type attachment plug rated 15 amperes, 250 volts.

For units intended to be operated at 230 volts (outside the U.S.): Use a cord set with a grounding-type attachment plug. The cord set should have the appropriate safety approvals for the country in which the equipment will be installed.

Power cords for a specific country or region are usually available only in that country or region.

<b>Power cord part number</b>	<b>Used in these countries and regions</b>
39M5206	China
39M5102	Australia, Fiji, Kiribati, Nauru, New Zealand, Papua New Guinea
39M5123	Afghanistan, Albania, Algeria, Andorra, Angola, Armenia, Austria, Azerbaijan, Belarus, Belgium, Benin, Bosnia and Herzegovina, Bulgaria, Burkina Faso, Burundi, Cambodia, Cameroon, Cape Verde, Central African Republic, Chad, Comoros, Congo (Democratic Republic of), Congo (Republic of), Cote D'Ivoire (Ivory Coast), Croatia (Republic of), Czech Republic, Dahomey, Djibouti, Egypt, Equatorial Guinea, Eritrea, Estonia, Ethiopia, Finland, France, French Guyana, French Polynesia, Germany, Greece, Guadeloupe, Guinea, Guinea Bissau, Hungary, Iceland, Indonesia, Iran, Kazakhstan, Kyrgyzstan, Laos (People's Democratic Republic of), Latvia, Lebanon, Lithuania, Luxembourg, Macedonia (former Yugoslav Republic of), Madagascar, Mali, Martinique, Mauritania, Mauritius, Mayotte, Moldova (Republic of), Monaco, Mongolia, Morocco, Mozambique, Netherlands, New Caledonia, Niger, Norway, Poland, Portugal, Reunion, Romania, Russian Federation, Rwanda, Sao Tome and Principe, Saudi Arabia, Senegal, Serbia, Slovakia, Slovenia (Republic of), Somalia, Spain, Suriname, Sweden, Syrian Arab Republic, Tajikistan, Tahiti, Togo, Tunisia, Turkey, Turkmenistan, Ukraine, Upper Volta, Uzbekistan, Vanuatu, Vietnam, Wallis and Futuna, Yugoslavia (Federal Republic of), Zaire
39M5130	Denmark
39M5144	Bangladesh, Lesotho, Macao, Maldives, Namibia, Nepal, Pakistan, Samoa, South Africa, Sri Lanka, Swaziland, Uganda
39M5151	Abu Dhabi, Bahrain, Botswana, Brunei Darussalam, Channel Islands, China (Hong Kong S.A.R.), Cyprus, Dominica, Gambia, Ghana, Grenada, Iraq, Ireland, Jordan, Kenya, Kuwait, Liberia, Malawi, Malaysia, Malta, Myanmar (Burma), Nigeria, Oman, Polynesia, Qatar, Saint Kitts and Nevis, Saint Lucia, Saint Vincent and the Grenadines, Seychelles, Sierra Leone, Singapore, Sudan, Tanzania (United Republic of), Trinidad and Tobago, United Arab Emirates (Dubai), United Kingdom, Yemen, Zambia, Zimbabwe
39M5158	Liechtenstein, Switzerland
39M5165	Chile, Italy, Libyan Arab Jamahiriya
39M5172	Israel
39M5095	220 - 240 V  Antigua and Barbuda, Aruba, Bahamas, Barbados, Belize, Bermuda, Bolivia, Caicos Islands, Canada, Cayman Islands, Colombia, Costa Rica, Cuba, Dominican Republic, Ecuador, El Salvador, Guam, Guatemala, Haiti, Honduras, Jamaica, Mexico, Micronesia (Federal States of), Netherlands Antilles, Nicaragua, Panama, Peru, Philippines, Saudi Arabia, Thailand, Taiwan, United States of America, Venezuela
39M5081	110 - 120 V  Antigua and Barbuda, Aruba, Bahamas, Barbados, Belize, Bermuda, Bolivia, Caicos Islands, Canada, Cayman Islands, Colombia, Costa Rica, Cuba, Dominican Republic, Ecuador, El Salvador, Guam, Guatemala, Haiti, Honduras, Jamaica, Mexico, Micronesia (Federal States of), Netherlands Antilles, Nicaragua, Panama, Peru, Philippines, Saudi Arabia, Thailand, Taiwan, United States of America, Venezuela
39M5219	Korea (Democratic People's Republic of), Korea (Republic of)
39M5199	Japan
39M5068	Argentina, Paraguay, Uruguay

<b>Power cord part number</b>	<b>Used in these countries and regions</b>
39M5226	India
39M5240	Brazil

---

## Chapter 5. Installing, removing, and replacing components

Use this information to install, remove, and replace the server components.

Replaceable components consist of the following:

- **Structural parts:** Purchase and replacement of structural parts (components, such as chassis assembly, top cover, and bezel) is your responsibility. If Lenovo acquires or installs a structural component at your request, you will be charged for the service.
- **Consumable parts:** Purchase and replacement of consumable parts (components, such as fan cage and blank fan filler) is your responsibility. If Lenovo acquires or installs a consumable component at your request, you will be charged for the service.
- **Tier 1 CRU:** Replacement of Tier 1 CRUs is your responsibility. If Lenovo installs a Tier 1 CRU at your request, you will be charged for the installation.
- **Tier 2 CRU:** You may install a Tier 2 CRU yourself or request Lenovo to install it, at no additional charge, under the type of warranty service that is designated for your server.

See Chapter 4 “Parts listing, Lenovo Storage DX8200” on page 111 to determine whether a component is a structural part, consumable part, Tier 1 CRU, or Tier 2 CRU.

For information about the terms of the warranty, see the *Warranty Information* document that comes with the server.

For more information about getting service and assistance, see Appendix D “Getting help and technical assistance” on page 1149.

---

### Returning a device or component

If you are instructed to return a device or component, follow all packaging instructions, and use any packaging materials for shipping that are supplied to you.

---

### Internal cable routing and connectors

This section provides information about routing the cables when you install some components in the server.

**Note:** Disengage all latches, release tabs or locks on cable connectors when you disconnect all cables from the system board. Failing to release them before removing the cables will damage the cable sockets on the system board. The cable sockets on the system board are fragile. Any damage to the cable sockets may require replacing the system board.

### General cable routing connections

#### Cabling VGA power connector

The internal routing and connectors for the front USB and video cables.

The following illustration shows the internal routing and connectors for the video graphic adapter (VGA) power cables:

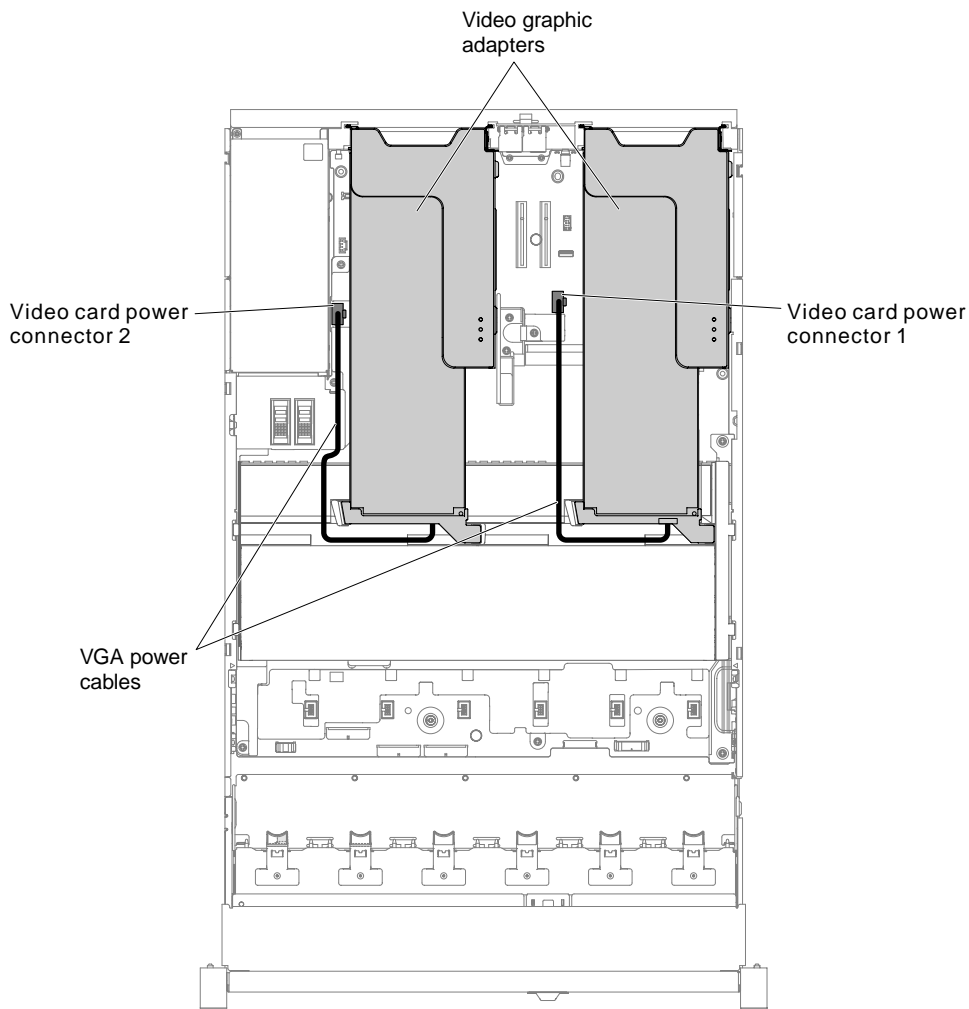

Figure 50. VGA power cables connection

## 2.5-inch hard disk drive cable connection

The following illustrations show the cabling information for the 2.5-inch drive models.

**Important:** Make sure all SAS cables are routed lower than the DIMM latches.

### 8x2.5-inch drive model

The internal routing for the 8x2.5-inch drive model cables.

The following illustration shows the internal routing for the 8x2.5-inch drive model cables.

**Note:** There might be 3 or 4 power connectors on the system board depending on your configuration. However, this difference will not affect the cable routing. Follow the following illustrations to complete your cable routing.



### 8x2.5-inch simple-swap hard disk drive model

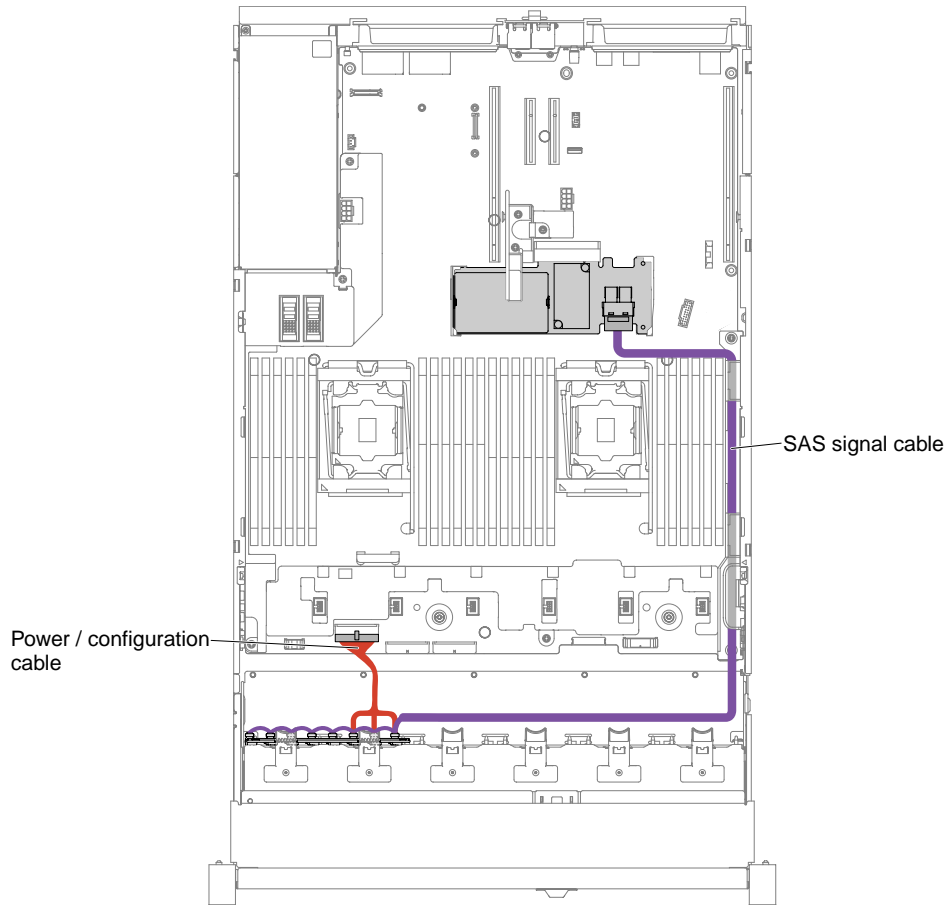

Figure 51. 8x2.5-inch simple-swap hard disk drive with hardware RAID cabling

### 8x2.5-inch hot-swap hard disk drive model

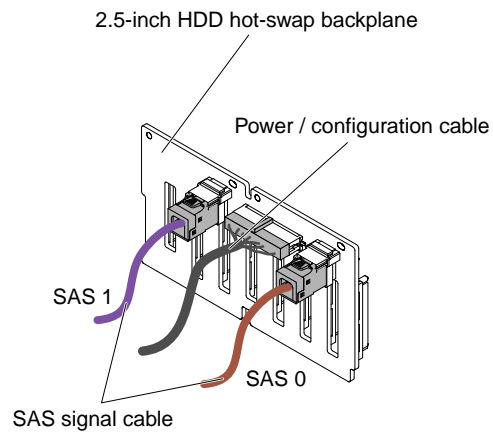

Figure 52. Cable connection

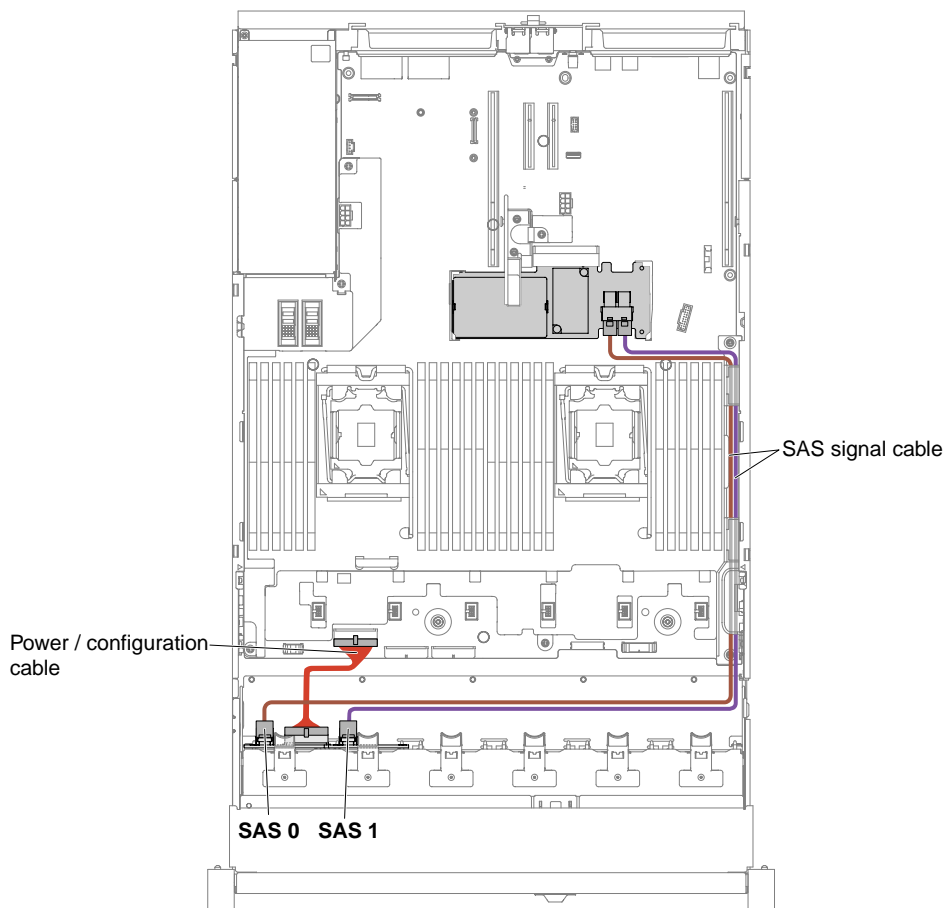

Figure 53. 8x2.5-inch hot-swap hard disk drive cabling

### 16x2.5-inch drive model

The internal routing for the 16x2.5-inch drive model cables.

The following illustration shows the internal routing for the 16x2.5-inch drive model cables.

**Note:** There might be 3 or 4 power connectors on the system board depending on your configuration. However, this difference will not affect the cable routing. Follow the following illustrations to complete your cable routing.

### 16x2.5-inch simple-swap hard disk drive model

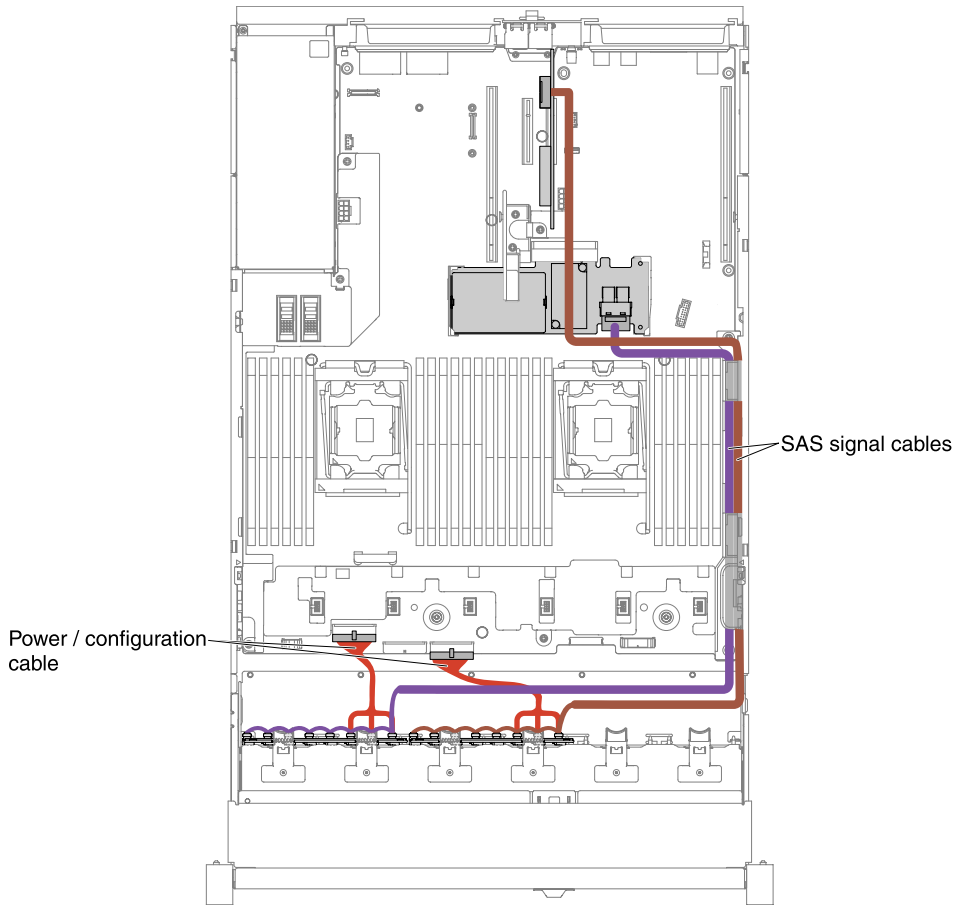

Figure 54. 16x2.5-inch simple-swap hard disk drive with hardware RAID cabling

### 16x2.5-inch hot-swap hard disk drive model

- 16x2.5-inch hot-swap hard disk drive with 2 identical backplanes

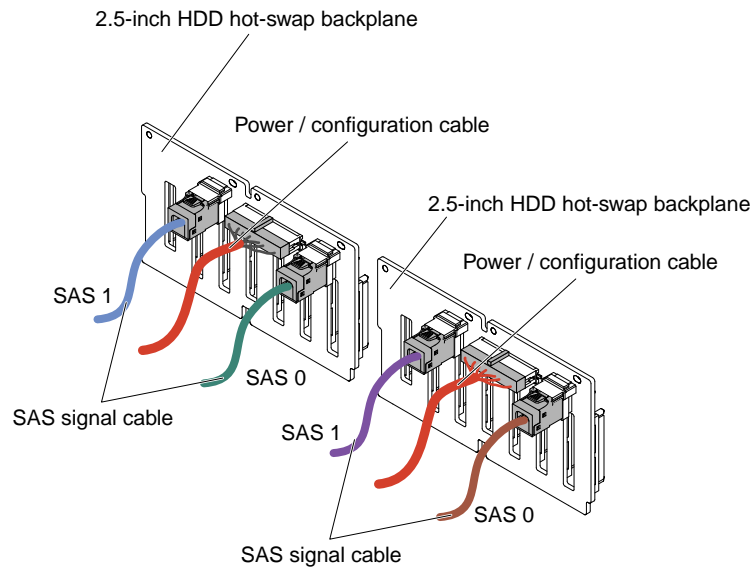

Figure 55. 16x2.5-inch hot-swap hard disk drive cabling

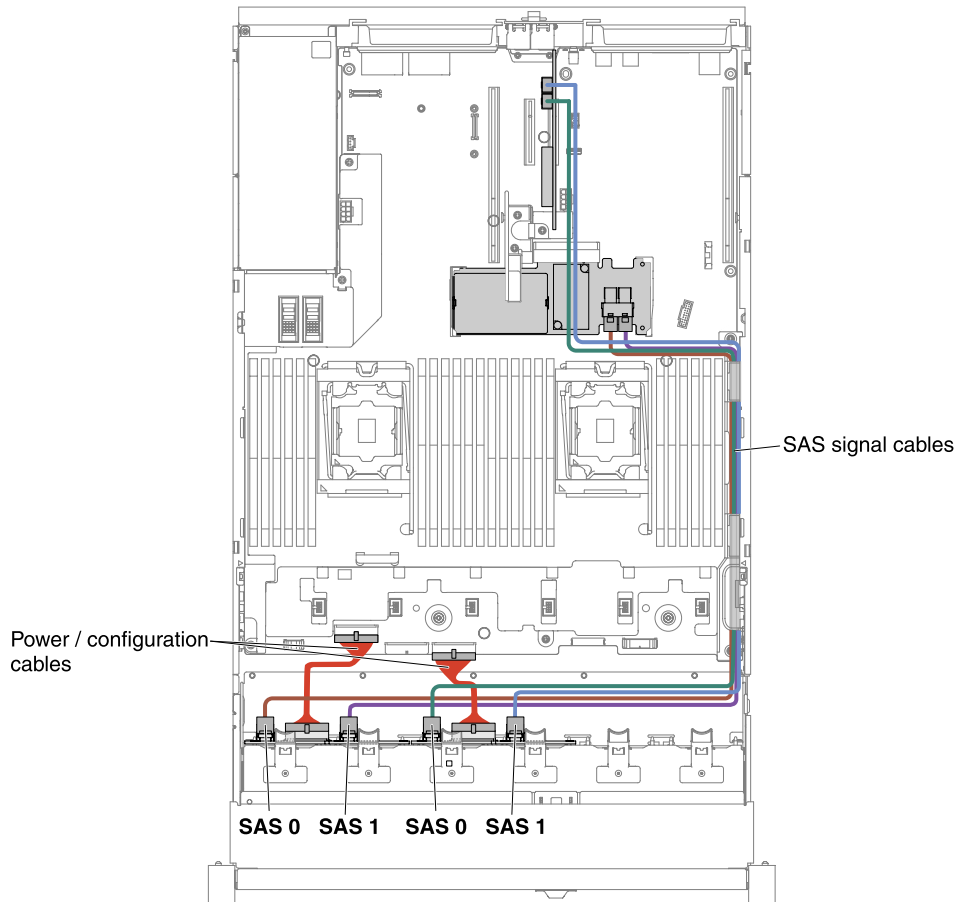

Figure 56. 16x2.5-inch hot-swap hard disk drive cabling

- 16x2.5-inch hot-swap hard disk drive with one expander

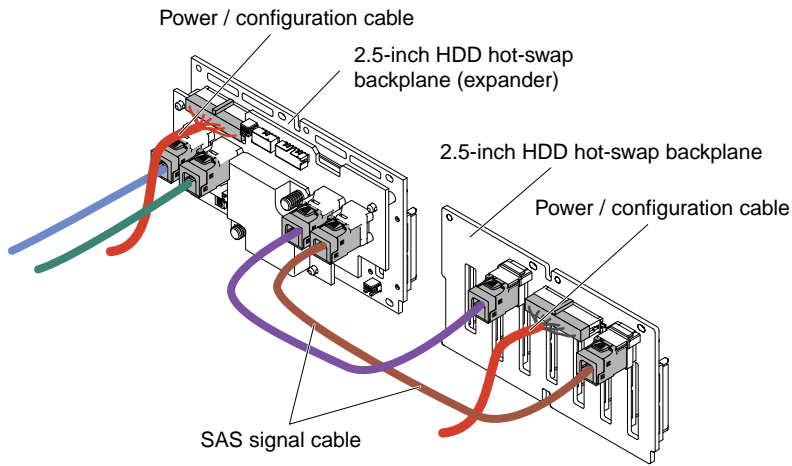

Figure 57. 16x2.5-inch hot-swap hard disk drive cable connection

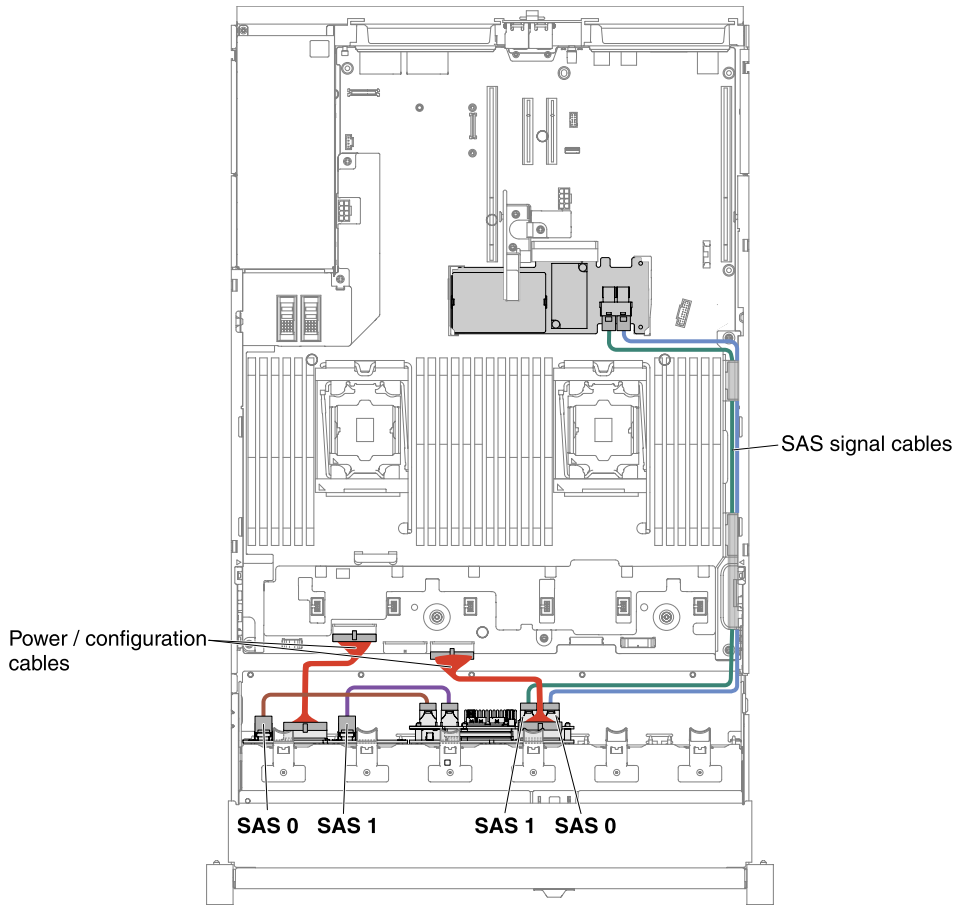

Figure 58. 16x2.5-inch hot-swap hard disk drive cabling

## 24x2.5-inch drive model

The internal routing for the 24x2.5-inch drive model cables.

The following illustration shows the internal routing for the 24x2.5-inch drive model cables.

**Note:** There might be 3 or 4 power connectors on the system board depending on your configuration. However, this difference will not affect the cable routing. Follow the following illustrations to complete your cable routing.

### 24x2.5-inch hot-swap hard disk drive model

- 24x2.5-inch hot-swap hard disk drive with 3 identical backplanes

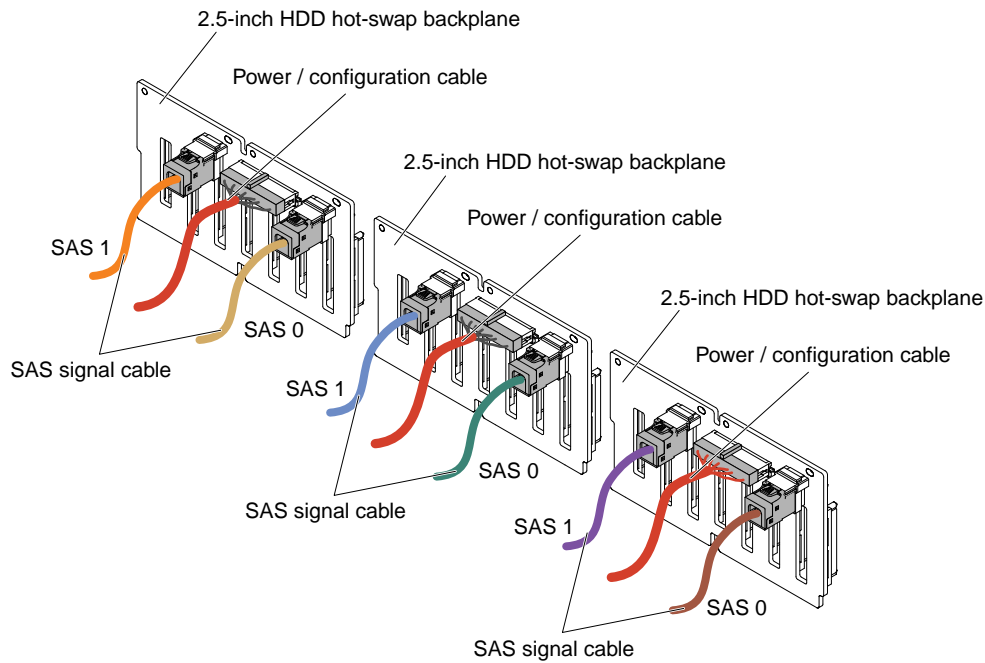

Figure 59. 24x2.5-inch hot-swap hard disk drive cabling

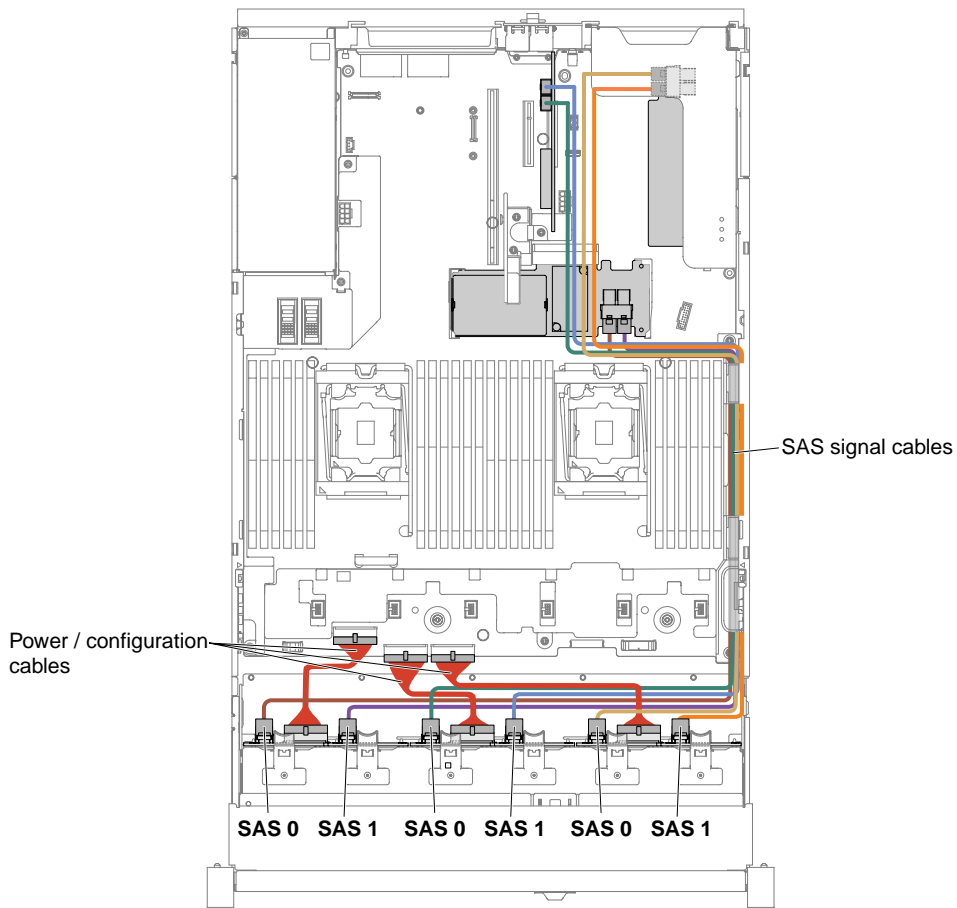

Figure 60. 24x2.5-inch hot-swap hard disk drive cabling

- 24x2.5-inch hot-swap hard disk drive with one expander

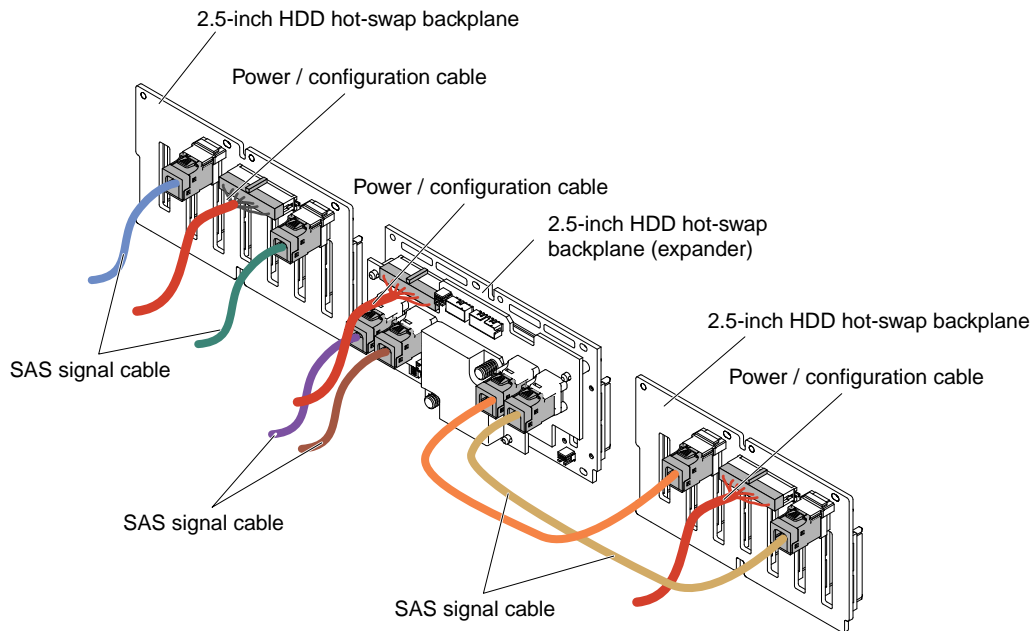

Figure 61. 24x2.5-inch hot-swap hard disk drive cabling

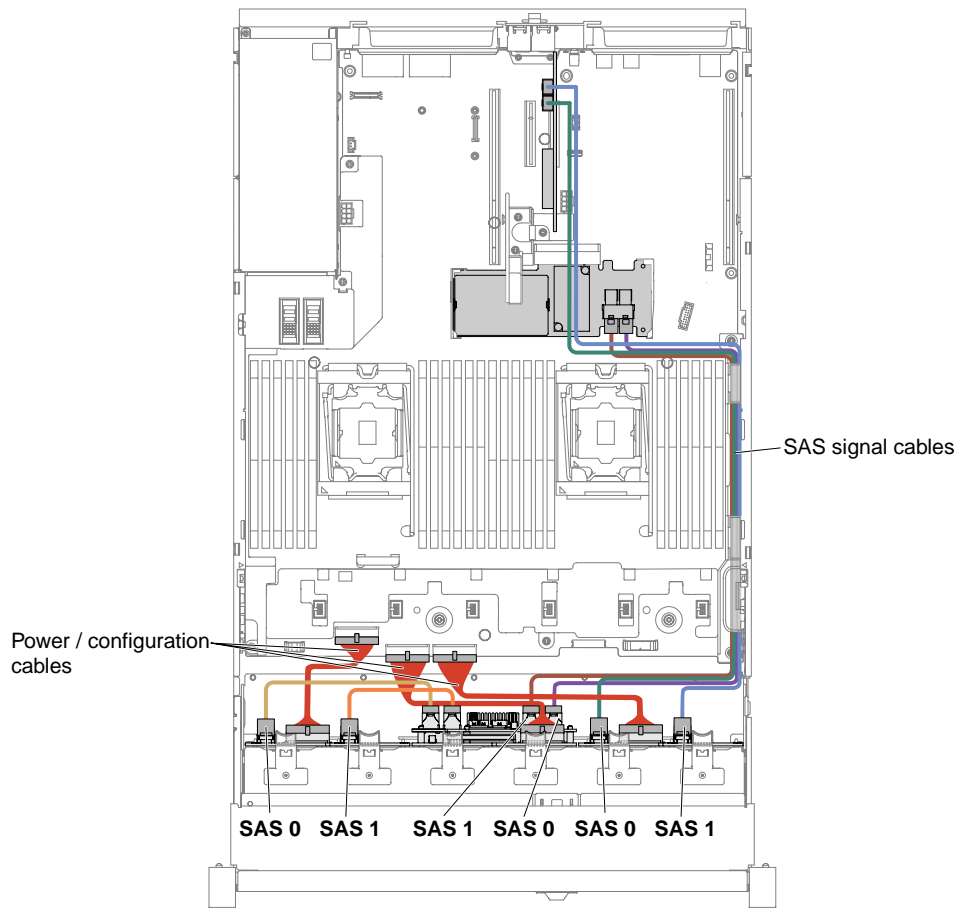

Figure 62. 24x2.5-inch hot-swap hard disk drive cabling

- 24x2.5-inch hot-swap hard disk drive with two expanders

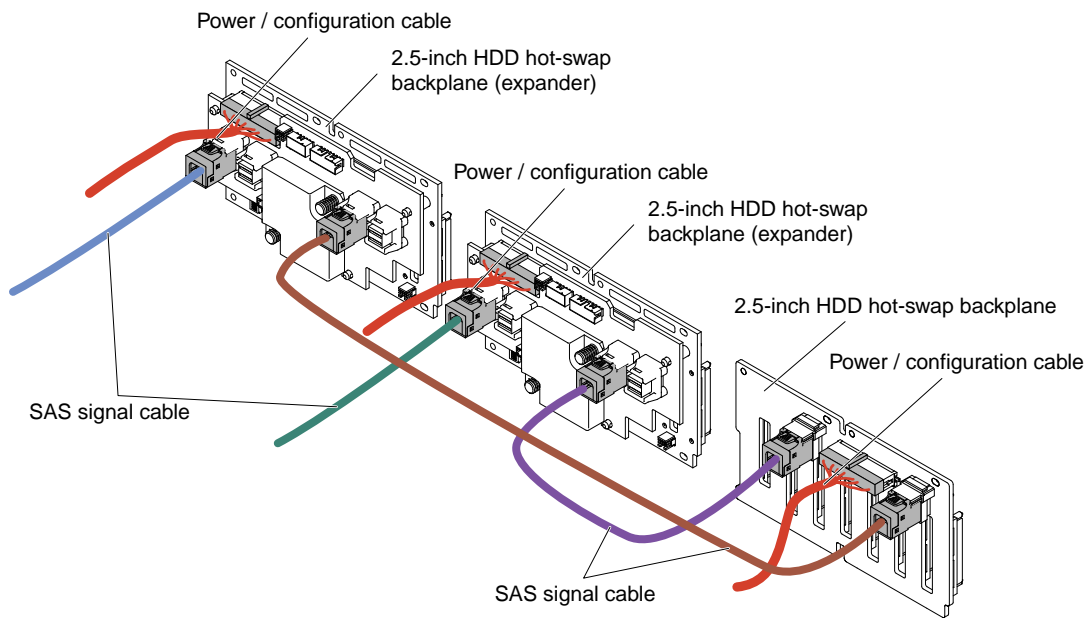

Figure 63. 24x2.5-inch hot-swap hard disk drive cable connection



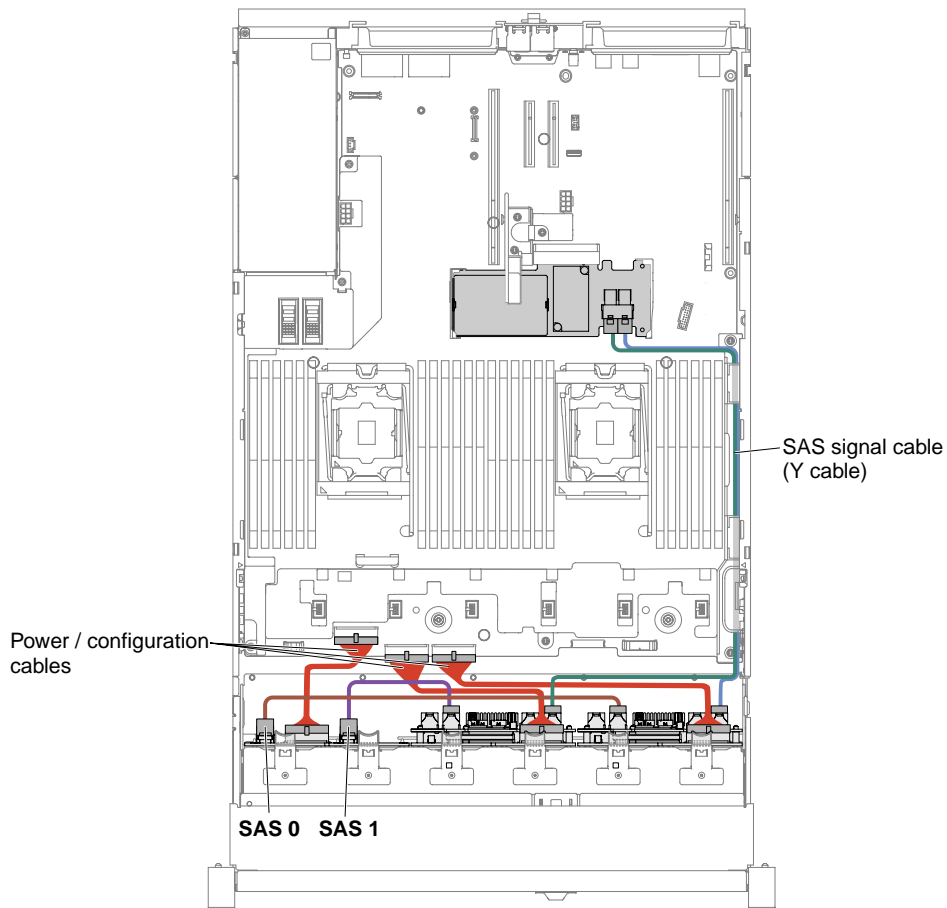

Figure 64. 24x2.5-inch hot-swap hard disk drive cabling

## 3.5-inch hard disk drive cable connection

The following illustrations show the cabling information for the 3.5-inch drive models.

**Important:** Make sure all SAS cables are routed lower than the DIMM latches.

### 8x3.5-inch drive model

The internal routing for the 8x3.5-inch drive model cables.

The following illustration shows the internal routing for the 8x3.5-inch drive model cables.

**Note:** There might be 3 or 4 power connectors on the system board depending on your configuration. However, this difference will not affect the cable routing. Follow the following illustrations to complete your cable routing.

### 8x3.5-inch simple-swap hard disk drive model

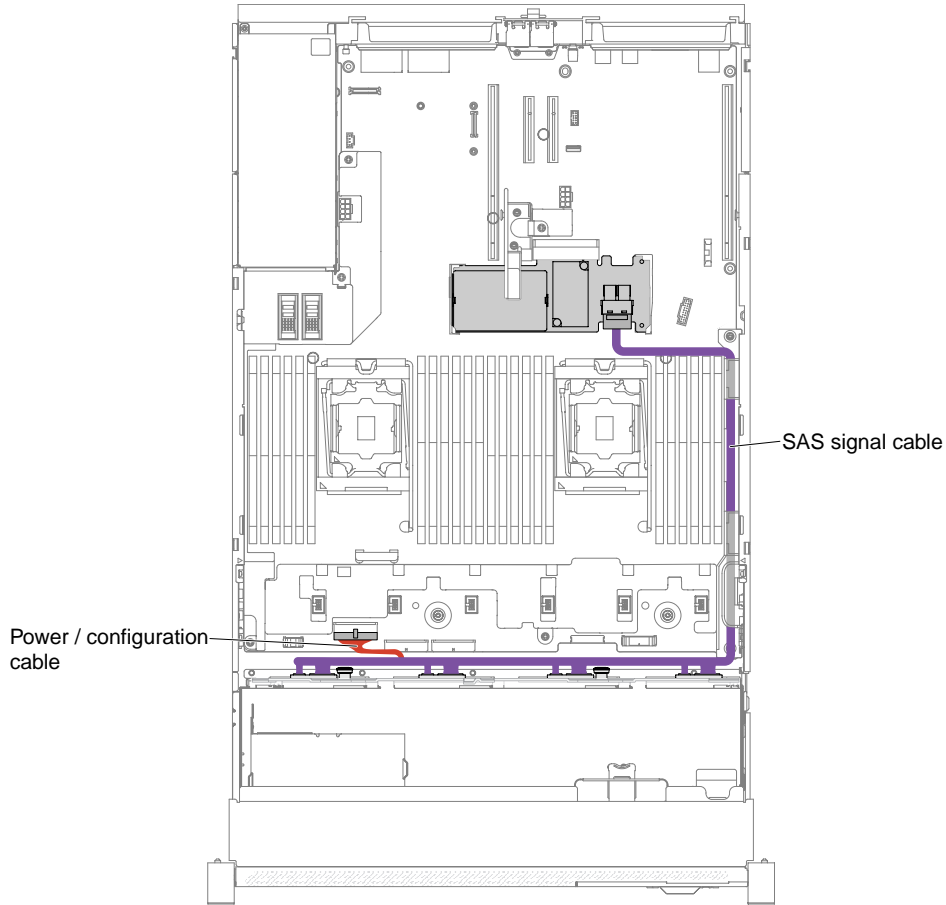

Figure 65. 8x3.5-inch simple-swap hard disk drives with hardware RAID cabling

### 8x3.5-inch hot-swap hard disk drive model

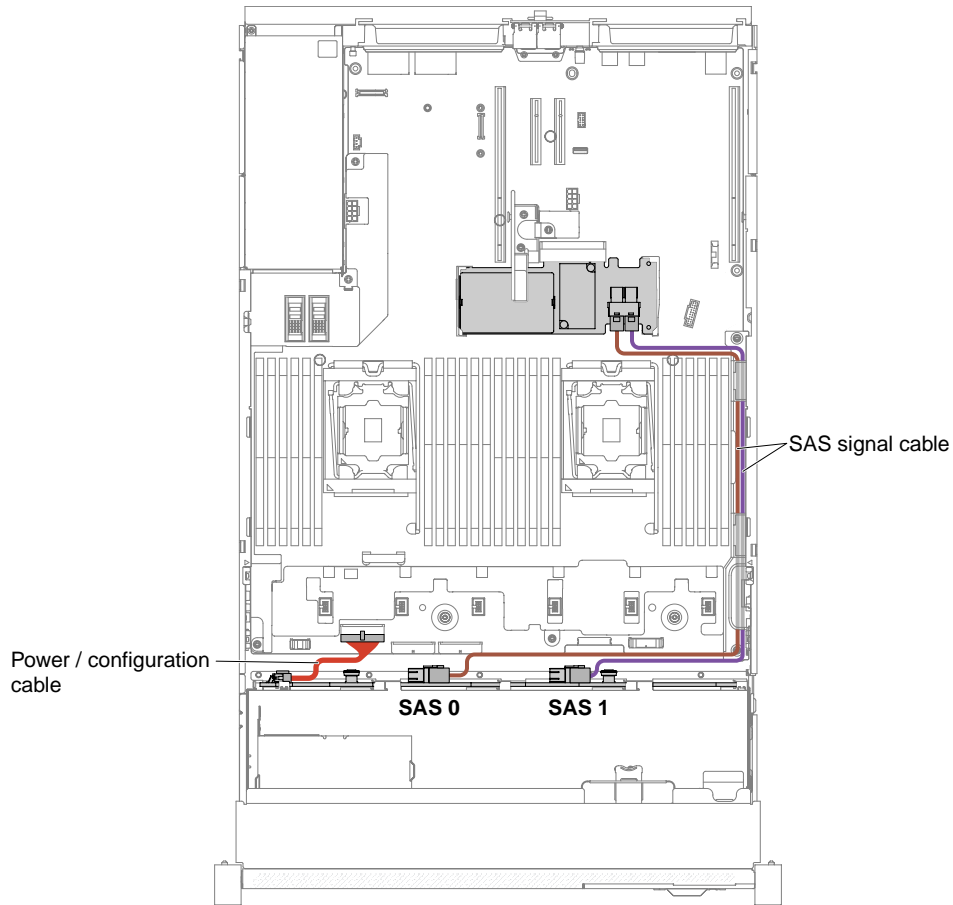

Figure 66. 8x3.5-inch hot-swap hard disk drives cabling

### 12x3.5-inch drive model

The internal routing for the 12x3.5-inch drive model cables.

The following illustration shows the internal routing for the 12x3.5-inch drive model cables.

**Note:** There might be 3 or 4 power connectors on the system board depending on your configuration. However, this difference will not affect the cable routing. Follow the following illustrations to complete your cable routing.

## 12x3.5-inch hot-swap hard disk drive model

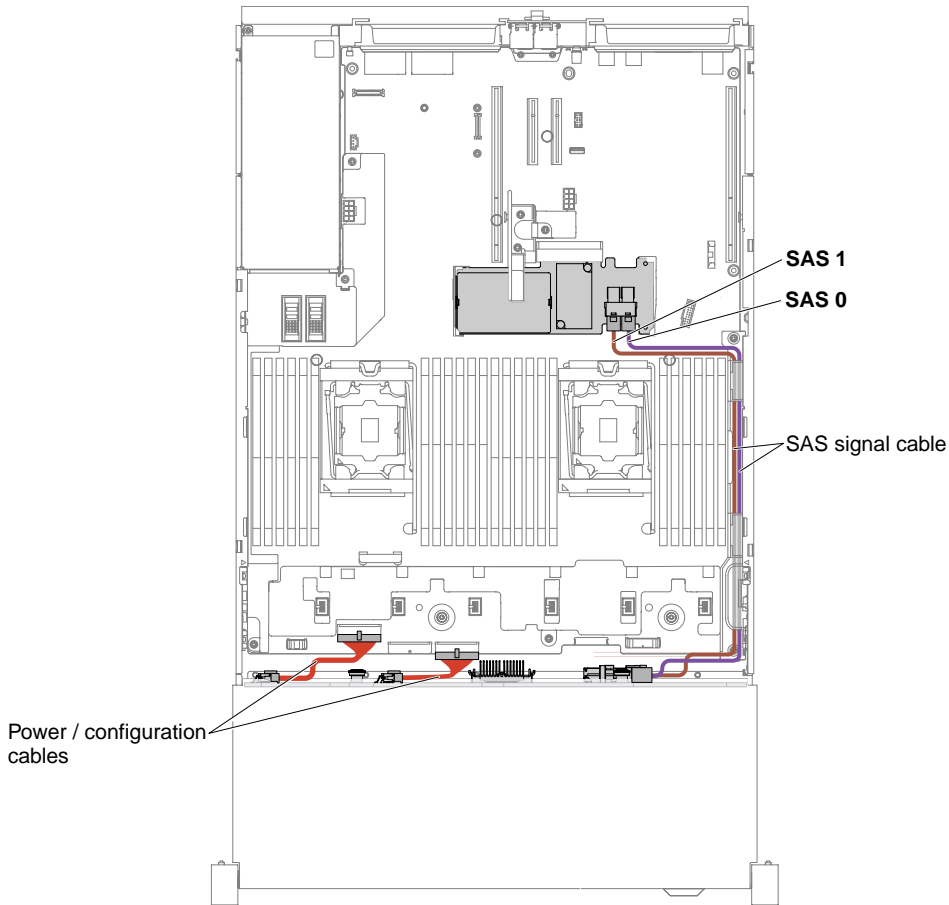

Figure 67. 12x3.5-inch hot-swap hard disk drive cabling

---

## Removing and replacing structural parts

Replacement of structural parts is your responsibility. If Lenovo installs a structural part at your request, you will be charged for the installation.

The illustrations in this document might differ slightly from your hardware.

## Removing the top cover

Use this information to remove the top cover.

To remove the top cover, complete the following steps:

- Step 1. Read the safety information that begins on page “Safety” on page v and “Installation guidelines” on page 287.
- Step 2. Turn off the server and peripheral devices and disconnect the power cords and all external cables, if necessary.

**Note:** If you need to view any LEDs on the system board or front panel, do so before you disconnect the power.

- Step 3. If the server has been installed in a rack, press down on the left and right side latches and slide the server out of the rack enclosure until both slide rails lock.

Step 4. Use a screwdriver to unscrew the cover lock to the open position as shown.

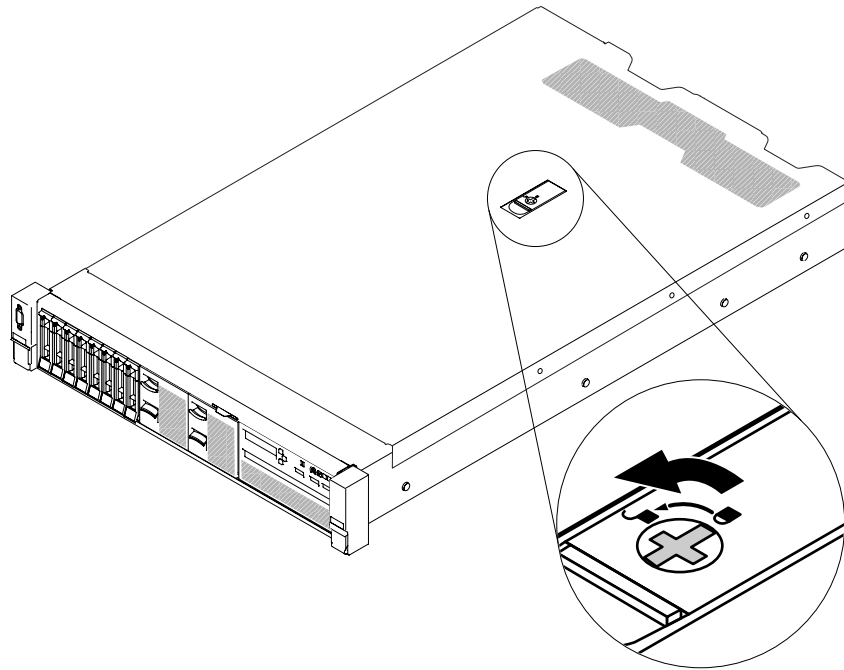

Figure 68. Unscrewing the cover lock

Step 5. **1** Push the tab on the cover-release latch, **2** then fully open the cover-release latch. Slide the top cover to the rear, **3** then lift the top cover off the server. Set the top cover aside.

**Attention:** For proper cooling and airflow, replace the server cover before you turn on the server.

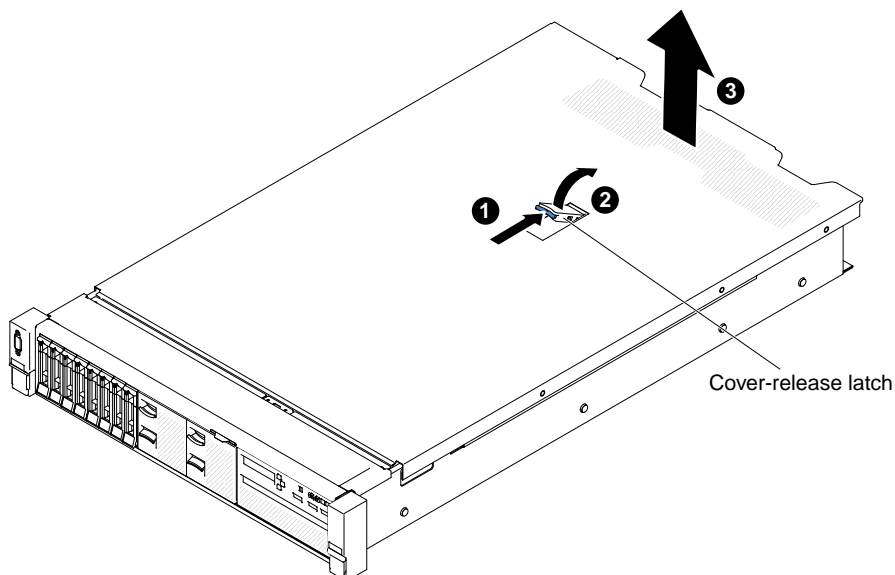

Figure 69. Top cover removal

Step 6. If you are instructed to return the top cover, follow all of the packaging instructions, and use any packaging materials for shipping that are supplied to you.

## Replacing the top cover

Use this information to replace the server top cover.

To replace the server top cover, complete the following steps:

Step 1. Make sure that all cables, adapters, and other components are installed and seated correctly and that you have not left loose tools or parts inside the server. Also, make sure that all internal cables are correctly routed.

**Important:** Before you slide the top cover forward, make sure that all the tabs and the pins on the top and side of the top cover engage the chassis correctly.

Step 2. Place the cover-release latch in the open (up) position.

Step 3. Position the top cover on top of the server.

Step 4. Insert the bottom tabs of the top cover into the matching slots in the server chassis.

Step 5. Pivot the cover-release latch as shown and slide the top cover to the front at the same time until the top cover snaps into position.

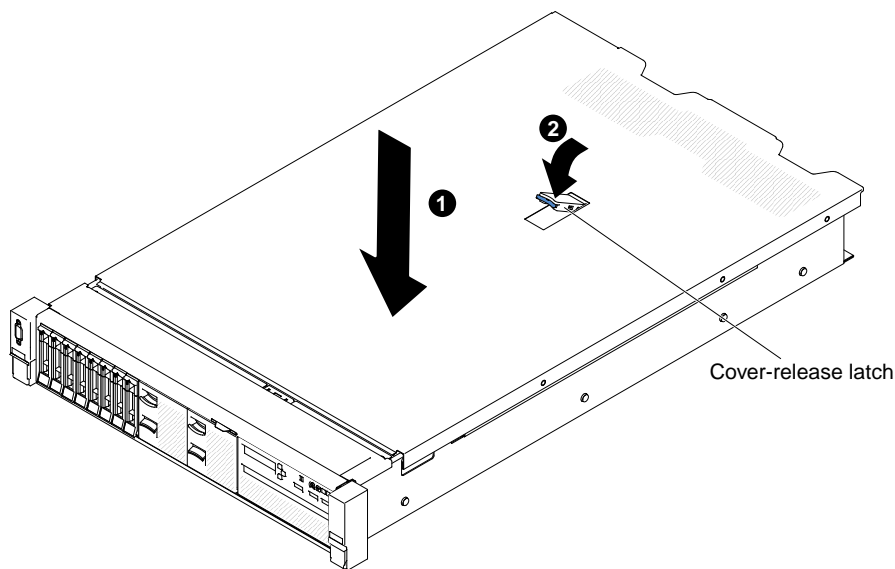
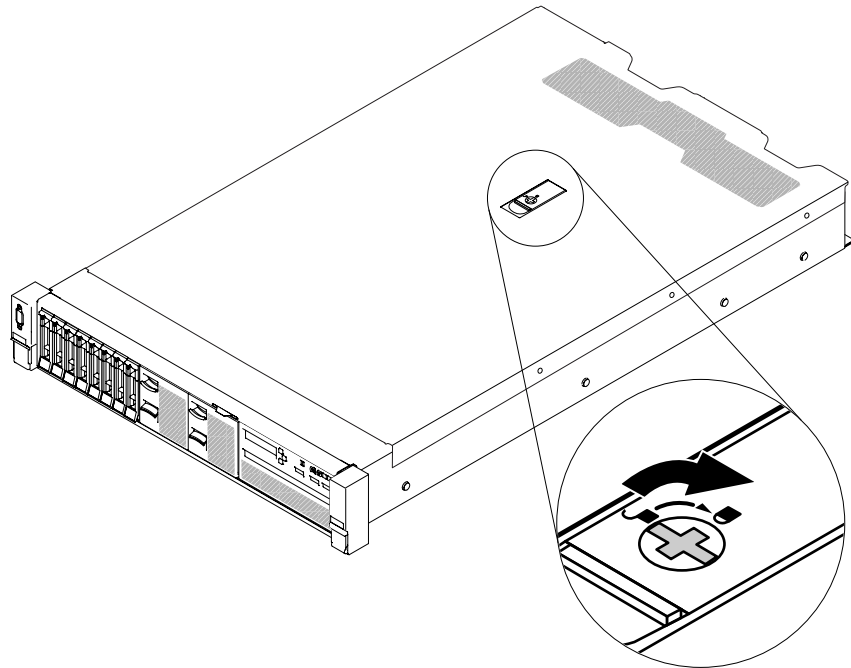

Figure 70. Top cover installation

Step 6. Use a screwdriver to turn the cover lock to the closed position.



*Figure 71. Closing the server cover completely*

- Step 7. Slide the server into the rack.
- Step 8. Reconnect the external cables and power cords.

---

## Removing and replacing Tier 1 CRUs

Replacement of Tier 1 CRUs is your responsibility. If Lenovo installs a Tier 1 CRU at your request, you will be charged for the installation.

The illustrations in this document might differ slightly from your hardware.

## Removing the air baffle

When you work with some optional devices, you must first remove the air baffle to access certain components or connectors on the system board. The following illustration shows how to remove the air baffle.

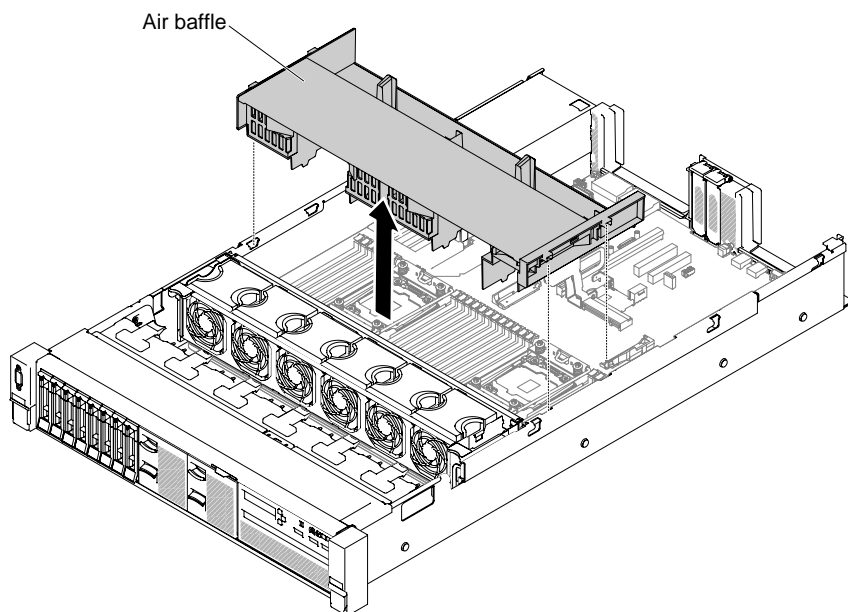

Figure 72. Air baffle removal

To remove the air baffle, complete the following steps:

- Step 1. Read the safety information that begins on page “Safety” on page v and “Installation guidelines” on page 287.
- Step 2. Turn off the server and peripheral devices and disconnect the power cords and all external cables (see “Turning off the server” on page 40).
- Step 3. Remove the top cover (see “Removing the top cover” on page 144).
- Step 4. Remove PCI riser-card assemblies, if needed (see “Removing a riser-card assembly” on page 180).
- Step 5. Disconnect the RAID adapter battery/flash power module cables, if needed.
- Step 6. Place your fingers under the back of the top of the air baffle; then, lift the air baffle out of the server.

**Attention:** For proper cooling and airflow, replace the air baffle before you turn on the server. Operating the server with the air baffle removed might damage server components.

- Step 7. If you are instructed to return the air baffle, follow all of the packaging instructions, and use any packaging materials for shipping that are supplied to you.

## Replacing the air baffle

Use this information to replace the air baffle.

To replace the air baffle, complete the following steps:

- Step 1. Read the safety information that begins on page “Safety” on page v and “Installation guidelines” on page 287.
- Step 2. Turn off the server and peripheral devices and disconnect the power cords and all external cables.
- Step 3. Remove the top cover (see “Removing the top cover” on page 144).
- Step 4. Align the air baffle tabs with the baffle slots on both sides of the chassis; then, lower the air baffle into the server. Press the air baffle down until it is securely seated.



**Note:** Close the retaining clip on each end of the DIMM connector before installing the air baffle for proper cooling.

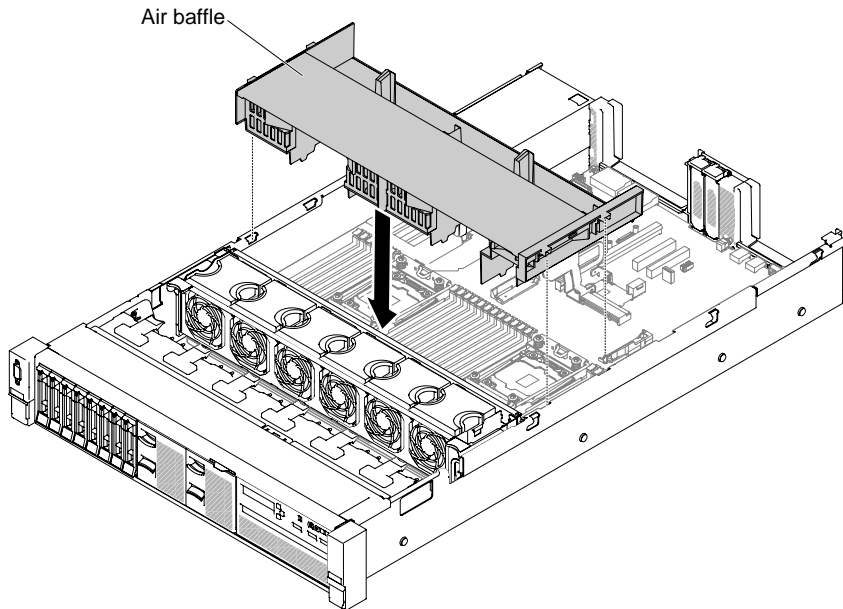

*Figure 73. Air baffle installation*

- Step 5. Replace PCI riser-card assemblies, if needed.
- Step 6. Reinstall the top cover (see “Replacing the top cover” on page 146).
- Step 7. Slide the server into the rack.
- Step 8. Reconnect the power cords and any cables that you removed.
- Step 9. Turn on the peripheral devices and the server.

## Removing the power paddle module

Use this information to remove the power paddle module.

To remove the power paddle module, complete the following steps:

- Step 1. Read the safety information that begins on “Safety” on page v and “Installation guidelines” on page 287.
- Step 2. Turn off the server, and disconnect all power cords and external cables.
- Step 3. Remove the top cover (see “Removing the top cover” on page 144).
- Step 4. Remove the power supplies. (See “Removing a hot-swap ac power supply” on page 228).
- Step 5. Grasp the handle and pull the power paddle module up.

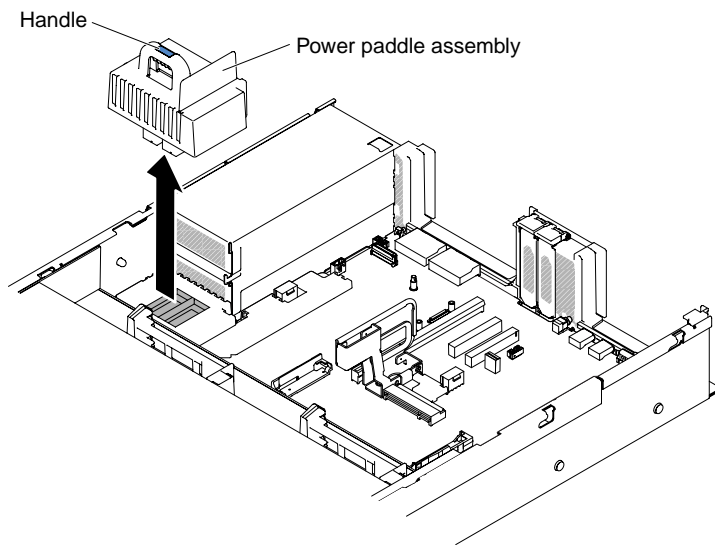

Figure 74. Power paddle module removal

- Step 6. If you are instructed to return the power paddle module, follow all packaging instructions, and use any packaging materials for shipping that are supplied to you.

## Replacing the power paddle module

Use this information to install the power paddle module.

To install the power paddle module, complete the following steps:

- Step 1. Read the safety information that begins on “Safety” on page v and “Installation guidelines” on page 287.
- Step 2. Turn off the server and peripheral devices and disconnect the power cords and all external cables, if necessary.
- Step 3. Remove the top cover (see “Removing the top cover” on page 144).
- Step 4. Grasp the handle and align the power paddle module with the connector on the system board. Push the power paddle module to the system board and make sure it is firmly seated.

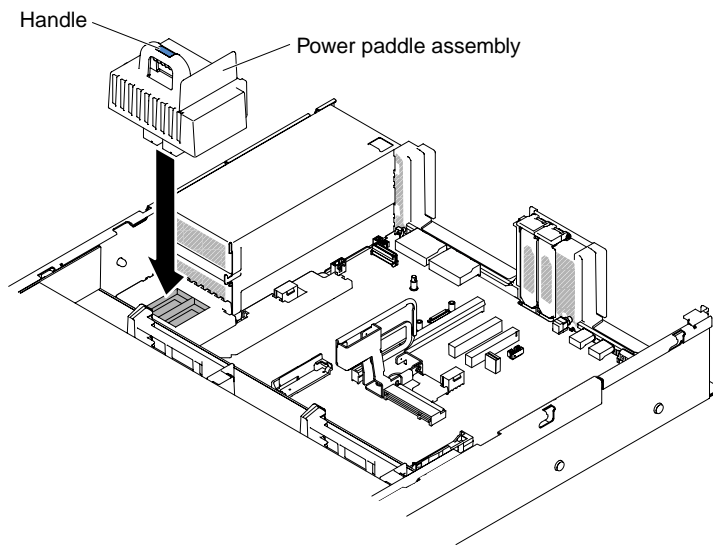

Figure 75. Power paddle module installation

- Step 5. Replacing the power supplies (See “Replacing a hot-swap ac power supply” on page 230).
- Step 6. Replacing the top cover (see “Replacing the top cover” on page 146).
- Step 7. Slide the server into the rack.
- Step 8. Reconnect the power cords and all external cables, and turn on the server and peripheral devices.

## Removing the front USB assembly

Use this information to remove the front USB assembly.

**Note:** The front USB assembly is available only on some models.

To remove the front USB assembly, complete the following steps.

- Step 1. Read the safety information that begins on “Safety” on page v and “Installation guidelines” on page 287.
- Step 2. Turn off the server and peripheral devices and disconnect the power cords and all external cables, if necessary.
- Step 3. Remove the top cover (see “Removing the top cover” on page 144).
- Step 4. Disconnect the cable on the front USB assembly from the system board.
- Step 5. **1** Pull up the release latch slightly and **2** slide the front USB assembly out of the server.

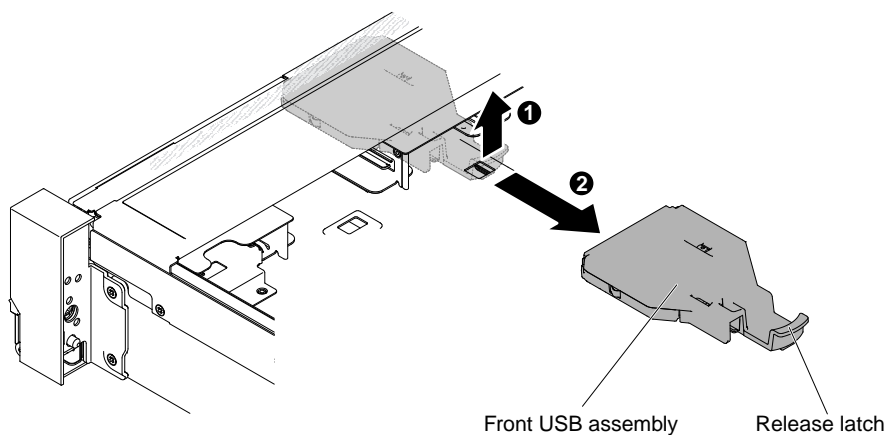

Figure 76. Front USB assembly removal

Step 6. If you are instructed to return the front USB assembly, follow all packaging instructions, and use any packaging materials for shipping that are supplied to you.

## Replacing the front USB assembly

Use this information to replace the front USB assembly.

**Note:** The front USB assembly is available only on some models.

To install the front USB assembly, complete the following steps.

- Step 1. Read the safety information that begins on “Safety” on page v and “Installation guidelines” on page 287.
- Step 2. Turn off the server and peripheral devices and disconnect the power cords and all external cables, if necessary.
- Step 3. Remove the top cover (see “Removing the top cover” on page 144).
- Step 4. Align and slide the front USB assembly into the server until it clicks into place.

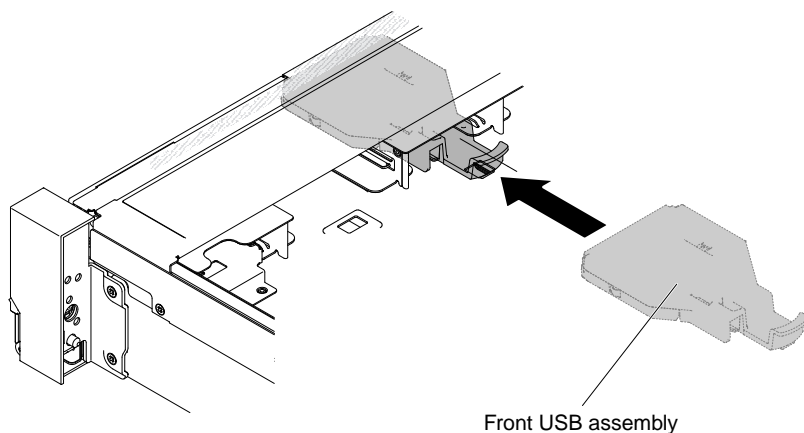

Figure 77. Front USB assembly installation

Step 5. Connect the cable on the front USB assembly to the system board.

The following illustration shows the cable routing for the front USB assembly.

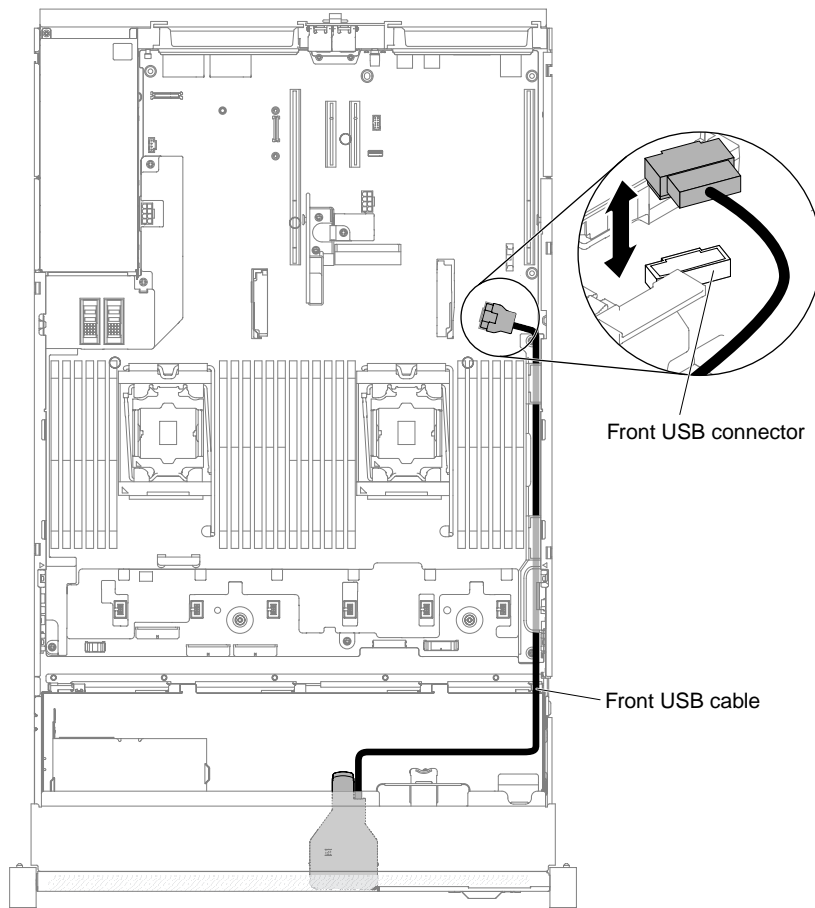

Figure 78. Front USB assembly cable routing

**Note:** To connect the front USB assembly cable on the system board, press evenly on the cable. Pressing on one side of the cable might cause damage to the cable or connector.

- Step 6. Replace the top cover (see “Replacing the top cover” on page 146).
- Step 7. Slide the server into the rack.
- Step 8. Reconnect the power cords and any cables that you removed.
- Step 9. Turn on the peripheral devices and the server.

## Removing a hot-swap hard disk drive

Use this information to remove a hot-swap hard disk drive.

### Attention:

- To avoid damage to the hard disk drive connectors, make sure that the server top cover is in place and fully closed whenever you install or remove a hard disk drive.
- To make sure that there is adequate system cooling, do not operate the server for more than 2 minutes without either a hard disk drive or a filler panel installed in each bay.
- Before you make changes to disk drives, disk drive controllers (including controllers that are integrated on the system board), disk drive backplanes, or disk drive cables, back up all important data that is stored on hard disks.
- Before you remove any component of a RAID array, back up all RAID configuration information.

To remove a hot-swap hard disk drive, complete the following steps.

- Step 1. Read the safety information that begins on “Safety” on page v and “Installation guidelines” on page 287.
- Step 2. Make sure you save the data on your drive, especially if it is part of a RAID array, before you remove it from the server.
- Step 3. Slide the latch to unlock the drive handle.

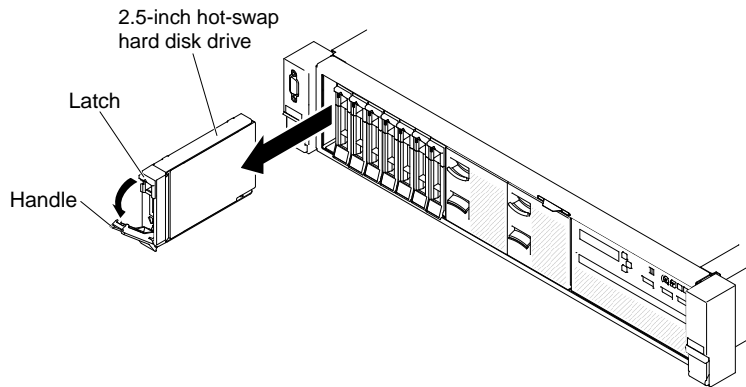

Figure 79. 2.5-inch hot-swap hard disk drives removal

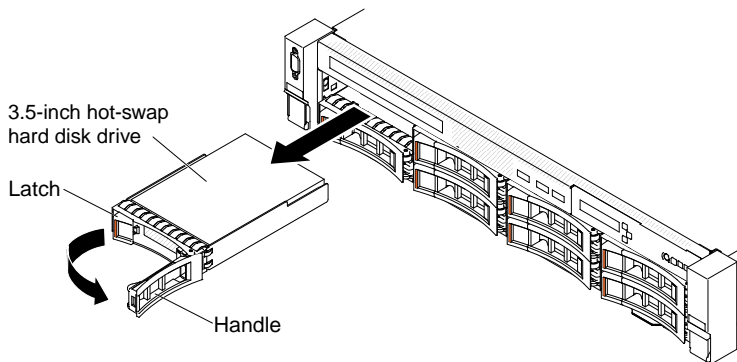

Figure 80. 3.5-inch hot-swap hard disk drives removal

- Step 4. Grasp the handle and slide the drive out of the drive bay.
- Step 5. Reinstall the drive bay filler panel.
- Step 6. If you are instructed to return the drive assembly, follow all packaging instructions, and use any packaging materials for shipping that are supplied to you.

## Replacing a hot-swap hard disk drive

Use this information to install a hot-swap hard disk drive.

The following notes describe the type of hard disk drives that the server supports and other information that you must consider when you install a hard disk drive. For a list of supported hard disk drives, see <http://www.lenovo.com/serverproven/>.

- Locate the documentation that comes with the hard disk drive and follow those instructions in addition to the instructions in this chapter.

- As a general consideration, do not mix standard 512-byte and advanced 4-KB format drives in the same RAID array because it may lead to potential performance issues.
- Make sure that you have all the cables and other equipment that are specified in the documentation that comes with the drive.
- Select the bay in which you want to install the drive.
- Check the instructions that come with the drive to determine whether you have to set any switches or jumpers on the drive. If you are installing a SAS or SATA hard disk drive, be sure to set the SAS or SATA ID for that device.
- The hot-swap server models support up to twenty-six 2.5-inch or fourteen 3.5-inch hot-swap SAS or SATA hard disk drives.
- The electromagnetic interference (EMI) integrity and cooling of the server are protected by having all bays and PCI Express slots covered or occupied. When you install a drive or a PCI Express adapter, save the EMC shield and filler panel from the bay or PCI Express adapter slot cover in the event that you later remove the device.
- For a complete list of supported optional devices for the server, see <http://www.lenovo.com/serverproven/>.

To install a hot-swap SAS or SATA hard disk drive, complete the following steps:

**Note:** If you have only one hard disk drive, you must install it in the bay 0 (upper-left).

- Step 1. Read the safety information that begins on “Safety” on page v and “Installation guidelines” on page 287.
- Step 2. Remove the filler panel from the empty drive bay. Keep the filler panel in a safe place.
- Step 3. Touch the static-protective package that contains the drive to any unpainted metal surface on the server; then, remove the drive from the package and place it on a static-protective surface.
- Step 4. Install the hard disk drive in the drive bay:
  - a. Make sure that the tray handle is in the open (unlocked) position.
  - b. Align the drive with the guide rails in the bay.

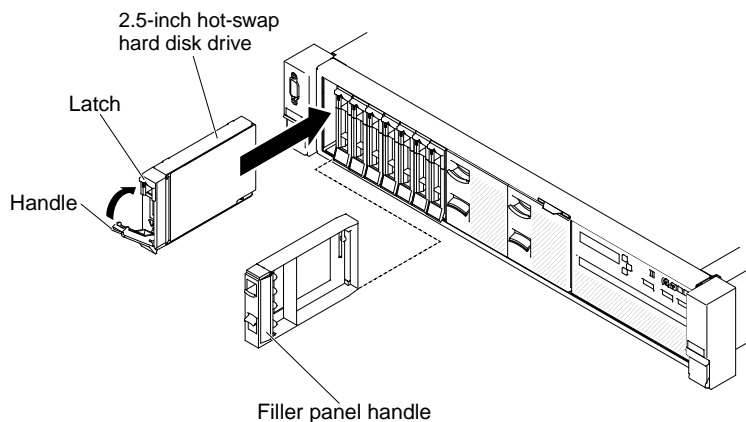

Figure 81. 2.5-inch hot-swap hard disk drives installation

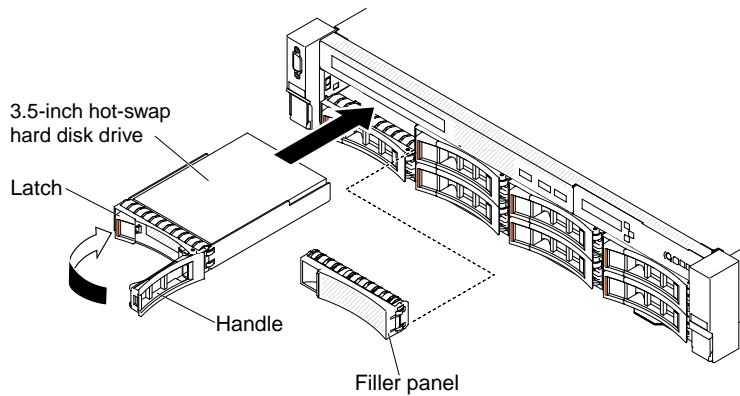

Figure 82. 3.5-inch hot-swap hard disk drives installation

- c. Gently push the drive into the bay until the drive stops.
- d. Rotate the tray handle to the closed (locked) position.
- e. Check the hard disk drive status LED to verify that the hard disk drive is operating correctly. If the yellow hard disk drive status LED of a drive is lit continuously, that drive is faulty and must be replaced. If the green hard disk drive activity LED is flashing, the drive is being accessed.

**Note:** If the server is configured for RAID operation using a ServeRAID adapter, you might have to reconfigure your disk arrays after you install hard disk drives. See the ServeRAID adapter documentation for additional information about RAID operation and complete instructions for using the ServeRAID adapter.

Step 5. If you are installing additional hot-swap hard disk drives, do so now.

Step 6. Turn on the peripheral devices and the server.

## Removing a simple-swap hard disk drive

Use this information to remove a simple-swap hard disk drive.

You must turn off the server before removing simple-swap drives from the server. To remove a simple-swap SATA hard disk drive, complete the following steps.

### Attention:

- To avoid damage to the hard disk drive connectors, make sure that the server cover is in place and fully closed whenever you install or remove a hard disk drive.
- To make sure that there is adequate system cooling, do not operate the server for more than 2 minutes without either a hard disk drive or a filler panel installed in each bay.

Step 1. Read the safety information that begins on “Safety” on page v and “Installation guidelines” on page 287.

Step 2. Turn off the server and peripheral devices and disconnect the power cords and all external cables.

Step 3. Pinch on the release latch and pull the hard disk drive out of the drive bay.



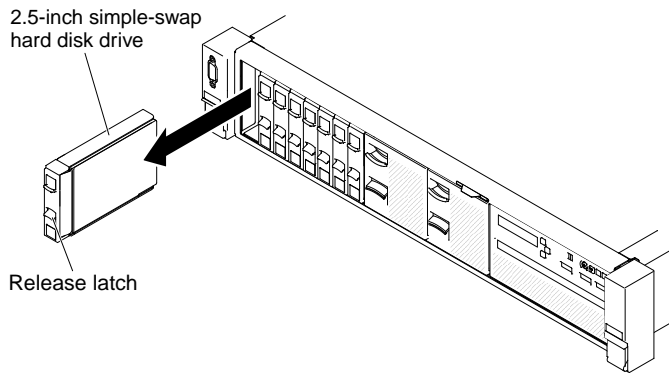

Figure 83. 2.5-inch simple-swap hard disk drive removal

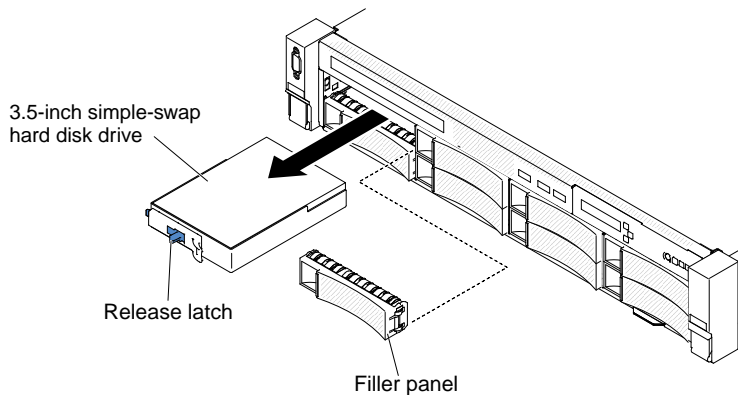

Figure 84. 3.5-inch simple-swap hard disk drive removal

- Step 4. Reinstall the drive bay filler panel that you removed earlier, if needed.
- Step 5. If you are instructed to return the drive assembly, follow all packaging instructions, and use any packaging materials for shipping that are supplied to you.

## Replacing a simple-swap hard disk drive

Use this information to install a simple-swap hard disk drive.

You must turn off the server before installing simple-swap drives in the server. Before you install a simple-swap SATA hard disk drive, read the following information. For a list of supported hard disk drives, see <http://www.lenovo.com/serverproven/>.

- Locate the documentation that comes with the hard disk drive and follow those instructions in addition to the instructions in this chapter.
- As a general consideration, do not mix standard 512-byte and advanced 4-KB format drives in the same RAID array because it may lead to potential performance issues.
- Make sure that you have all the cables and other equipment that are specified in the documentation that comes with the drive.
- Select the bay in which you want to install the drive.
- Check the instructions that come with the drive to determine whether you have to set any switches or jumpers on the drive. If you are installing a SATA device, be sure to set the SATA ID for that device.
- The simple-swap server models support up to sixteen 2.5-inch or eight 3.5-inch simple-swap SATA hard disk drives. Do not install hot-swap drives into a simple-swap server model, it is not supported.

- You can install one 2.5-inch simple-swap SATA hard disk drives in bay 0 in the server. Do not install hot-swap drives into a simple-swap server model, it is not supported.
- The simple-swap server models are available only in non-RAID configurations.
- The electromagnetic interference (EMI) integrity and cooling of the server are protected by having all bays and PCI Express slots covered or occupied. When you install a drive or a PCI Express adapter, save the EMC shield and filler panel from the bay or PCI Express adapter slot cover in the event that you later remove the device.

To install a simple-swap hard disk drive, complete the following steps:

- Step 1. Read the safety information that begins on “Safety” on page v and “Installation guidelines” on page 287.
- Step 2. Turn off the server and peripheral devices and disconnect the power cords and all external cables.
- Step 3. Remove the filler panel from the empty drive bay.
- Step 4. Touch the static-protective package that contains the drive to any unpainted metal surface on the server; then, remove the drive from the package and place it on a static-protective surface.
- Step 5. Install the hard disk drive in the drive bay. Align the drive assembly with the guide rails in the bay and gently push the drive into the bay until the drive stops.

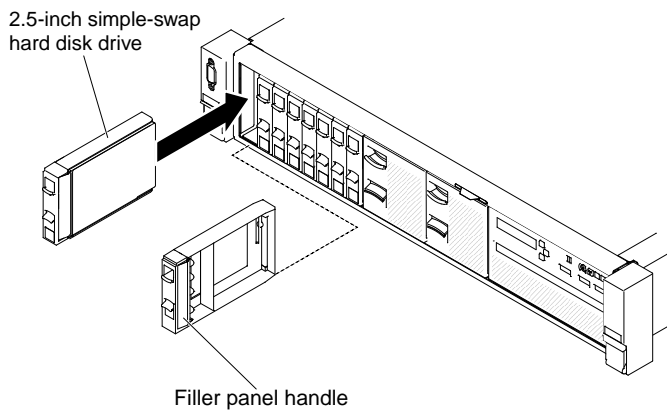

Figure 85. 2.5-inch simple-swap hard disk drive installation

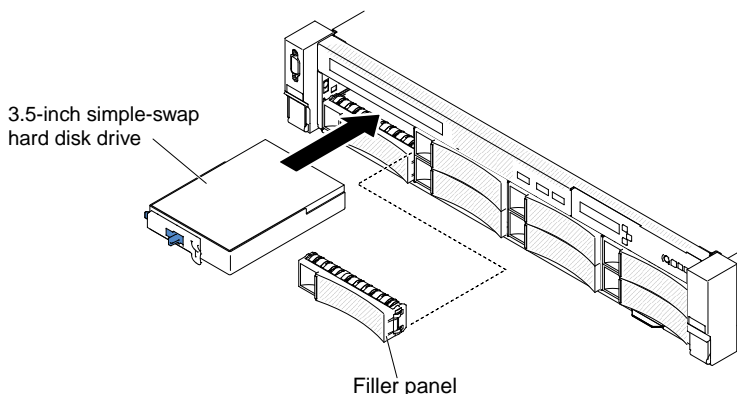

Figure 86. 3.5-inch simple-swap hard disk drive installation

- Step 6. Reinstall the drive bay filler panel that you removed earlier, if needed.
- Step 7. If you are installing additional simple-swap hard disk drives, do so now.

Step 8. Turn on the peripheral devices and the server.

## Removing the optical drive cable

Use this information to remove the optical drive cable.

**Note:** The optical drive is available only on some models.

To remove the optical cable, complete the following steps:

- Step 1. Read the safety information that begins on “Safety” on page v and “Installation guidelines” on page 287.
- Step 2. Turn off the server and peripheral devices and disconnect the power cords.
- Step 3. Remove the top cover (see “Removing the top cover” on page 144).
- Step 4. Remove the fan cage assembly (see “Removing the fan cage assembly” on page 172).
- Step 5. Pull the connector toward the front of the server to remove the optical drive cable from the connector on the system board.

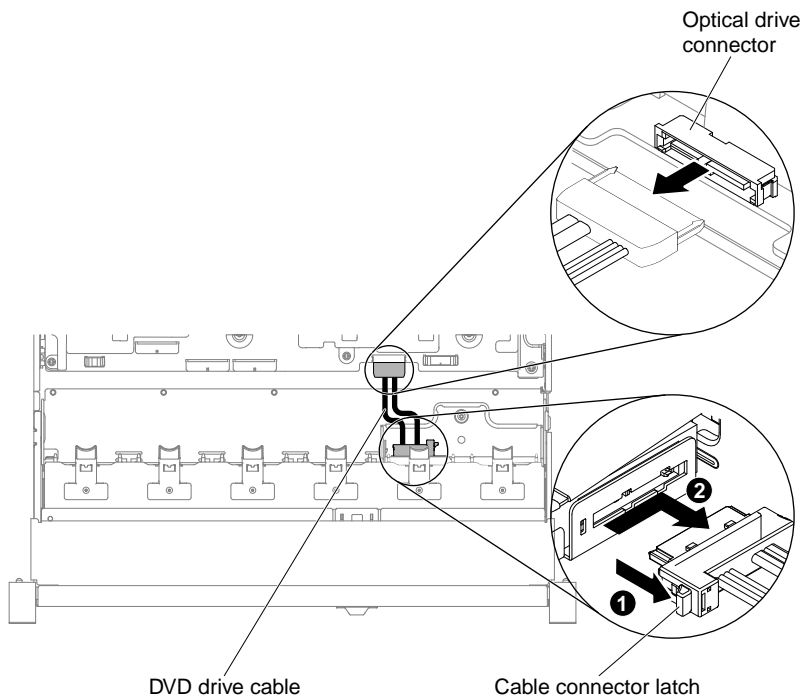

Figure 87. Optical drive cable connection

- Step 6. From the rear of the optical drive cage, **1** press and hold the connector latch (on the left of the cable connector). At the same time, **2** grasp the cable connector and slide it to the right. Remove the optical drive cable from the connector on the rear of the optical drive cage.

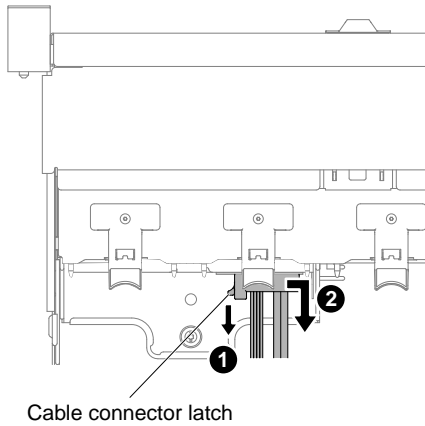

Figure 88. Optical drive cable latch



Step 7. If you are instructed to return the optical drive cable, follow all packaging instructions, and use any packaging materials for shipping that are supplied to you.

## Replacing the optical drive cable

Use this information to install the optical drive cable.

**Note:** The optical drive is available only on some models.

To install the optical drive cable, complete the following steps:

- Step 1. Read the safety information that begins on “Safety” on page v and “Installation guidelines” on page 287.
- Step 2. Turn off the server and peripheral devices and disconnect the power cords and all external cables.
- Step 3. Remove the top cover (see “Removing the top cover” on page 144).
- Step 4. Remove the fan cage assembly (see “Removing the fan cage assembly” on page 172).
- Step 5. Align the cable connector with the slot on the rear of the optical drive cage.  Press and hold the connector latch; then,  push the cable connector into the optical drive cage connector and slide it to the left until it is firmly seated.

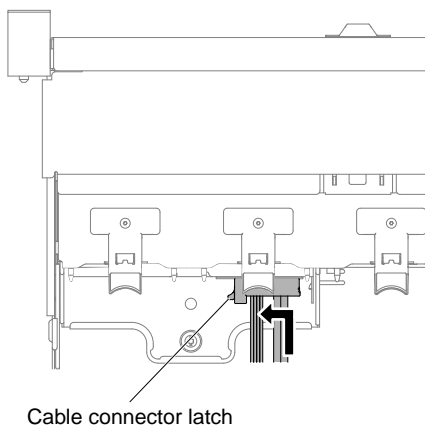

Figure 89. Optical drive cable latch

The following illustration shows cable routing for the optical cable:

**Attention:** Follow the optical drive cable routing as the illustration shows. Make sure that the cable is not pinched and does not cover any connectors or obstruct any components on the system board.

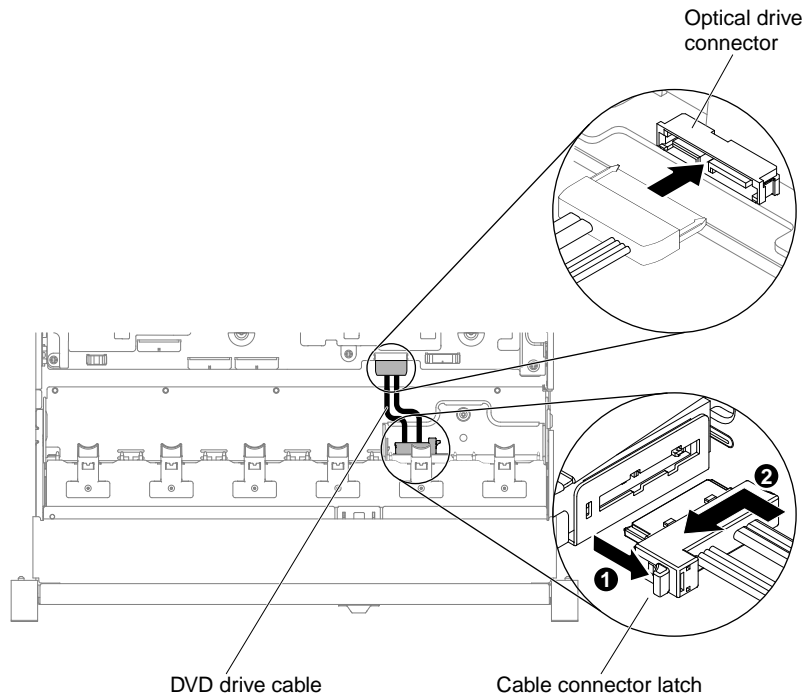

Figure 90. Optical drive cable routing

- Step 6. Replace the fan cage assembly (see “Replacing the fan cage assembly” on page 173).
- Step 7. Replace the top cover (see “Replacing the top cover” on page 146).
- Step 8. Slide the server into the rack.
- Step 9. Reconnect the power cords and any cables that you removed.
- Step 10. Turn on the peripheral devices and the server.

## Removing an optical drive

Use this information to remove an optical drive.

You can go to “Front view” on page 18 to see the locations of an optical drive on the server.

**Note:** The optical drive is available only on some models.

To remove an optical drive, complete the following steps:

- Step 1. Read the safety information that begins on “Safety” on page v and “Installation guidelines” on page 287.
- Step 2. Turn off the server and peripheral devices and disconnect all power cords.
- Step 3. Remove the server top cover (see “Removing the top cover” on page 144).
- Step 4. **1** Press and hold the release tab to the right as you **2** push the drive from the rear to slide it out of the bay.

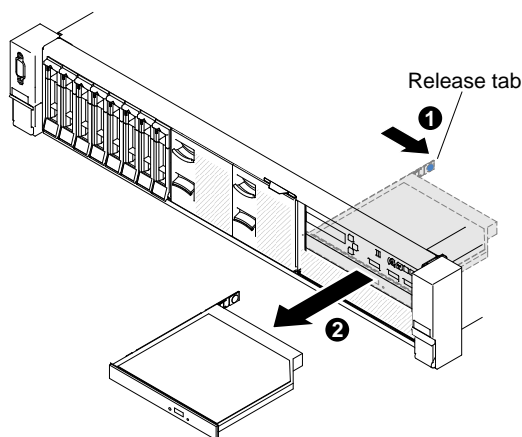

Figure 91. Optical drive removal

- Step 5. Slide the drive retention clip from the side of the drive. Save the clip to use when you install the replacement drive or replace the optical drive filler panel.

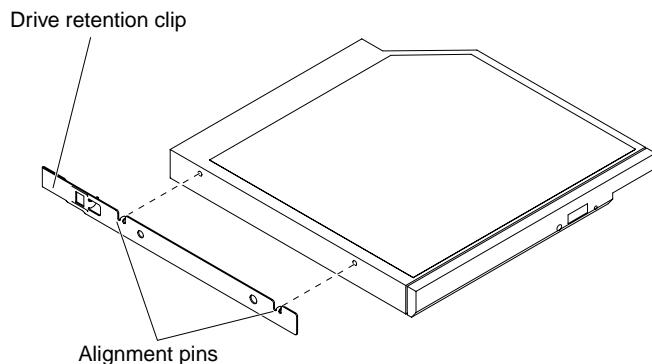

Figure 92. Optical drive retention clip removal

- Step 6. Attach the drive retention clip to the side of the optical drive filler panel that you removed in Step 4 on page 163.
- Step 7. Slide the optical drive filler panel into the optical drive bay until the optical drive filler panel clicks into place.
- Step 8. If you are instructed to return the optical drive, follow all packaging instructions, and use any packaging materials for shipping that are supplied to you.

## Replacing an optical drive

Use this information to install an optical drive.

The following notes describe the type of drives that the server supports and other information that you must consider when you install a drive. For a list of supported drives, see <http://www.lenovo.com/serverproven/>.

- You can go to “Front view” on page 18 to see the locations of an optical drive on the server.
- Locate the documentation that comes with the drive and follow those instructions in addition to the instructions in this chapter.
- Make sure that you have all the cables and other equipment that are specified in the documentation that comes with the drive.
- The server supports one ultra-slim SATA optical drive.

**Note:** The optical drive is available only on some models.

To install an optional optical drive, complete the following steps:

Step 1. Read the safety information that begins on “Safety” on page v and “Installation guidelines” on page 287.

Step 2. Turn off the server and peripheral devices and disconnect the power cords and all external cables.

**Note:** When you disconnect the power source from the server, you lose the ability to view the LEDs because the LEDs are not lit when the power source is removed. Before you disconnect the power source, make a note of which LEDs are lit, including the LEDs that are lit on the operation information panel, and LEDs inside the server on the system board.

Step 3. Remove the top cover (see “Removing the top cover” on page 144).

Step 4. Remove the optical drive filler panel if it is installed. Locate the blue release tab on the rear of the optical drive filler panel; then, while you press the tab, push the optical drive filler panel out of the drive bay.

Step 5. Remove the retention clip from the side of the optical drive filler panel. Save the optical drive filler panel for future use.

**Note:** If you are installing an optical drive that contains a laser, observe the following safety precautions.

### Statement 3



#### CAUTION:

**When laser products (such as CD-ROMs, optical drives, fiber optic devices, or transmitters) are installed, note the following:**

- **Do not remove the covers. Removing the covers of the laser product could result in exposure to hazardous laser radiation. There are no serviceable parts inside the device.**
- **Use of controls or adjustments or performance of procedures other than those specified herein might result in hazardous radiation exposure.**



 **DANGER**

**Some laser products contain an embedded Class 3A or Class 3B laser diode. Note the following.**  
**Laser radiation when open. Do not stare into the beam, do not view directly with optical instruments, and avoid direct exposure to the beam.**



Class 1 Laser Product  
Laser Klasse 1  
Laser Klass 1  
Luokan 1 Laserlaite  
Appareil À Laser de Classe 1

- Step 6. Touch the static-protective package that contains the new optical drive to any unpainted metal surface on the server; then, remove the optical drive from the package and place it on a static-protective surface.
- Step 7. Follow the instructions that come with the drive to set any jumpers or switches.
- Step 8. Attach the drive retention clip that you removed from the optical drive filler panel to the side of the new optical drive.

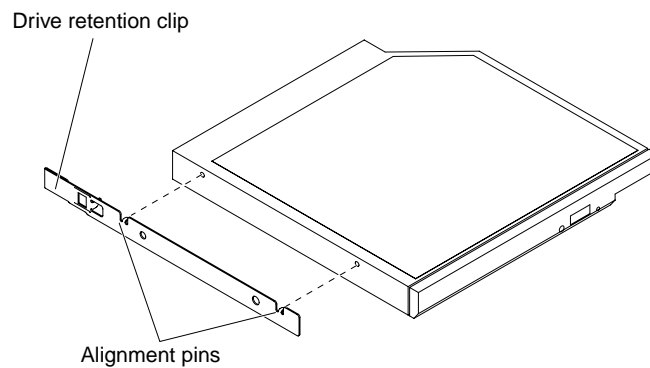

Figure 93. Optical drive retention clip installation

- Step 9. Align the optical drive in the drive bay and slide the optical drive into the optical drive bay until the optical drive clicks into place.

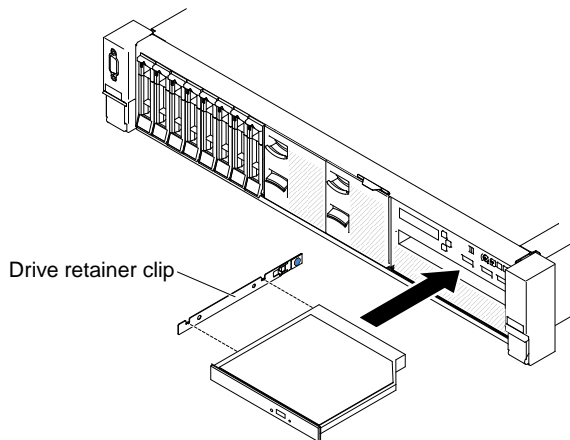

Figure 94. Optical drive installation

- Step 10. Connect the optical drive cable (see “Replacing the optical drive cable” on page 160).
- Step 11. Reconnect the power cords and any cables that you removed.
- Step 12. Turn on the peripheral devices and the server.



## Removing a memory module

Use this information to remove a memory module.

To remove a dual inline memory module (DIMM), complete the following steps:

- Step 1. Read the safety information that begins on “Safety” on page v and “Installation guidelines” on page 287.
- Step 2. Turn off the server and peripheral devices and disconnect all power cords.
- Step 3. Remove the top cover (see “Removing the top cover” on page 144).
- Step 4. Remove the air baffle (see “Removing the air baffle” on page 147).
- Step 5. Carefully open the retaining clips on each end of the DIMM connector and remove the DIMM.

**Attention:** To avoid breaking the retaining clips or damaging the DIMM connectors, open and close the clips gently.

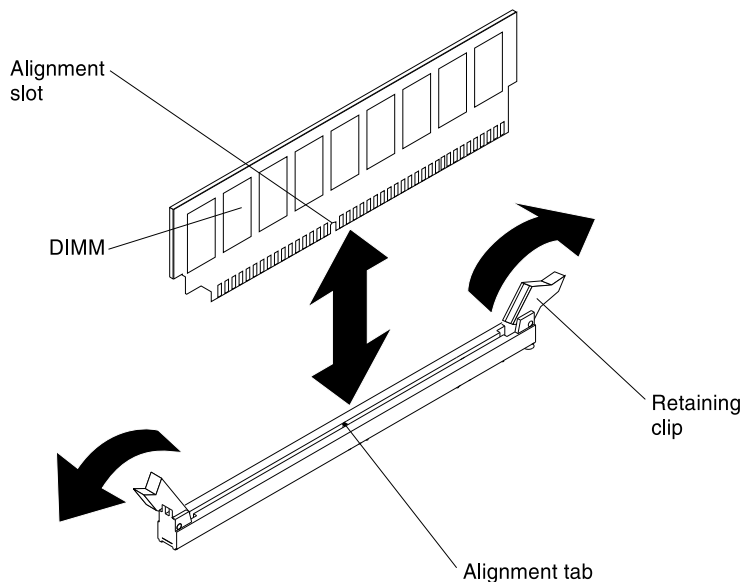

Figure 95. DIMM removal

- Step 6. If you are instructed to return the DIMM, follow all packaging instructions, and use any packaging materials for shipping that are supplied to you.

## Installing a memory module

The following notes describe the types of DIMMs that the server supports and other information that you must consider when you install DIMMs.

- When you install or remove DIMMs, the server configuration information changes. When you restart the server, the system displays a message that indicates that the memory configuration has changed.
- The server supports only industry-standard double-data-rate 4 (DDR4), 2400 MHz, PC4-19200 registered or load deduction, synchronous dynamic random-access memory (SDRAM) dual inline memory modules (DIMMs) with error correcting code (ECC). See <http://www.lenovo.com/serverproven/> for a list of supported memory modules for the server.
  - The specifications of a DDR4 DIMM are on a label on the DIMM, in the following format.

*ggggeRxff PC4v-wwwwwm-aa-bb-ccd*

where:

- *ggggg* is the total capacity of the DIMM (for example, 1GB, 2GB, or 4GB)
- *eR* is the number of ranks
  - 1R = single-rank
  - 2R = dual-rank
  - 4R = quad-rank
- *xff* is the device organization (bit width)
  - x4 = x4 organization (4 DQ lines per SDRAM)
  - x8 = x8 organization
  - x16 = x16 organization
- *v* is the SDRAM and support component supply voltage (VDD)
  - Blank = 1.2 V specified
- *wwwww* is the DIMM bandwidth, in MBps
  - 12800 = 12.80 Gbps (DDR4-1600 SDRAMs, 8-byte primary data bus)
  - 14900 = 14.93 Gbps (DDR4-1866 SDRAMs, 8-byte primary data bus)
  - 17000 = 17.00 Gbps (DDR4-2133 SDRAMs, 8-byte primary data bus)
  - 19200 = 19.20 Gbps (DDR4-2400 SDRAMs, 8-byte primary data bus)
- *m* is the DIMM type
  - L = Load Reduction DIMM (LRDIMM)
  - R = Registered DIMM (RDIMM)
- *aa* is the CAS latency, in clocks at maximum operating frequency
- *bb* is the JEDEC SPD Revision Encoding and Additions level
- *cc* is the reference design file for the design of the DIMM
- *d* is the revision number of the reference design of the DIMM

**Note:** To determine the type of a DIMM, see the label on the DIMM. The information on the label is in the format *xxxxx nRxxx PC4v-xxxxxx-xx-xx-xxx*. The numeral in the sixth numerical position indicates whether the DIMM is single-rank (*n*=1), dual-rank (*n*=2), or quad-rank (*n*=4).

- The following rules apply to 2400 MHz DDR4 RDIMM speed as it relates to the number of RDIMMs in a channel:
  - When you install 1 RDIMM per channel, the memory runs at 2400 MHz
  - When you install 2 RDIMMs per channel, the memory runs at 2400 MHz
  - When you install 3 RDIMMs per channel, the memory runs at 1866 MHz
  - All channels in a server run at the fastest common frequency
  - Do not install registered and load reduction DIMMs in the same server
- The following rules apply to 2400 MHz DDR4 LRDIMM speed as it relates to the number of LRDIMMs in a channel:
  - When you install 1 LRDIMM per channel, the memory runs at 2400 MHz
  - When you install 2 LRDIMMs per channel, the memory runs at 2400 MHz
  - When you install 3 LRDIMMs per channel, the memory runs at 2133 MHz
- The maximum memory speed is determined by the combination of the microprocessor, DIMM speed, DIMM type, Operating Modes in UEFI settings, and the number of DIMMs installed in each channel.

- The server supports a maximum of 24 single-rank, dual-rank RDIMMs or 24 quad-rank LRDIMMs.
- The following table shows an example of the maximum amount of memory that you can install using ranked DIMMs:

Table 11. Maximum memory installation using ranked DIMMs

Number of DIMMs	DIMM type	DIMM size	Total memory
24	Single-rank RDIMMs	8 GB	192 GB
24	Dual-rank RDIMMs	8 GB	192 GB
24	Dual-rank RDIMMs	16 GB	384 GB
24	Dual-rank RDIMMs	32 GB	768 GB
24	Quad-rank LRDIMMs	64 GB	1.5 TB

- The RDIMM options that are available for the server are 8 GB, 16 GB, and 32 GB. The server supports a minimum of 8 GB and a maximum of 768 GB of system memory using RDIMMs.
- The LRDIMM option that is available for the server is 64 GB. The server supports a minimum of 64 GB and a maximum of 1.5 TB of system memory using LRDIMMs.

**Note:** The amount of usable memory is reduced depending on the system configuration. A certain amount of memory must be reserved for system resources. To view the total amount of installed memory and the amount of configured memory, run the Setup Utility. For additional information, see “Configuring the server” on page 44.

- A minimum of one DIMM must be installed for each microprocessor. For example, you must install a minimum of two DIMMs if the server has two microprocessors installed. However, to improve system performance, install a minimum of four DIMMs for each microprocessor.
- DIMMs in the server must be the same type (RDIMM or LRDIMM) to ensure that the server will operate correctly.

**Notes:**

1. You can install DIMMs for microprocessor 2 as soon as you install microprocessor 2; you do not have to wait until all of the DIMM slots for microprocessor 1 are filled.
2. DIMM slots 13-24 are reserved for microprocessor 2; thus, DIMM slots 13-24 are enabled when microprocessor 2 is installed.

The following illustration shows the location of the DIMM connectors on the system board.

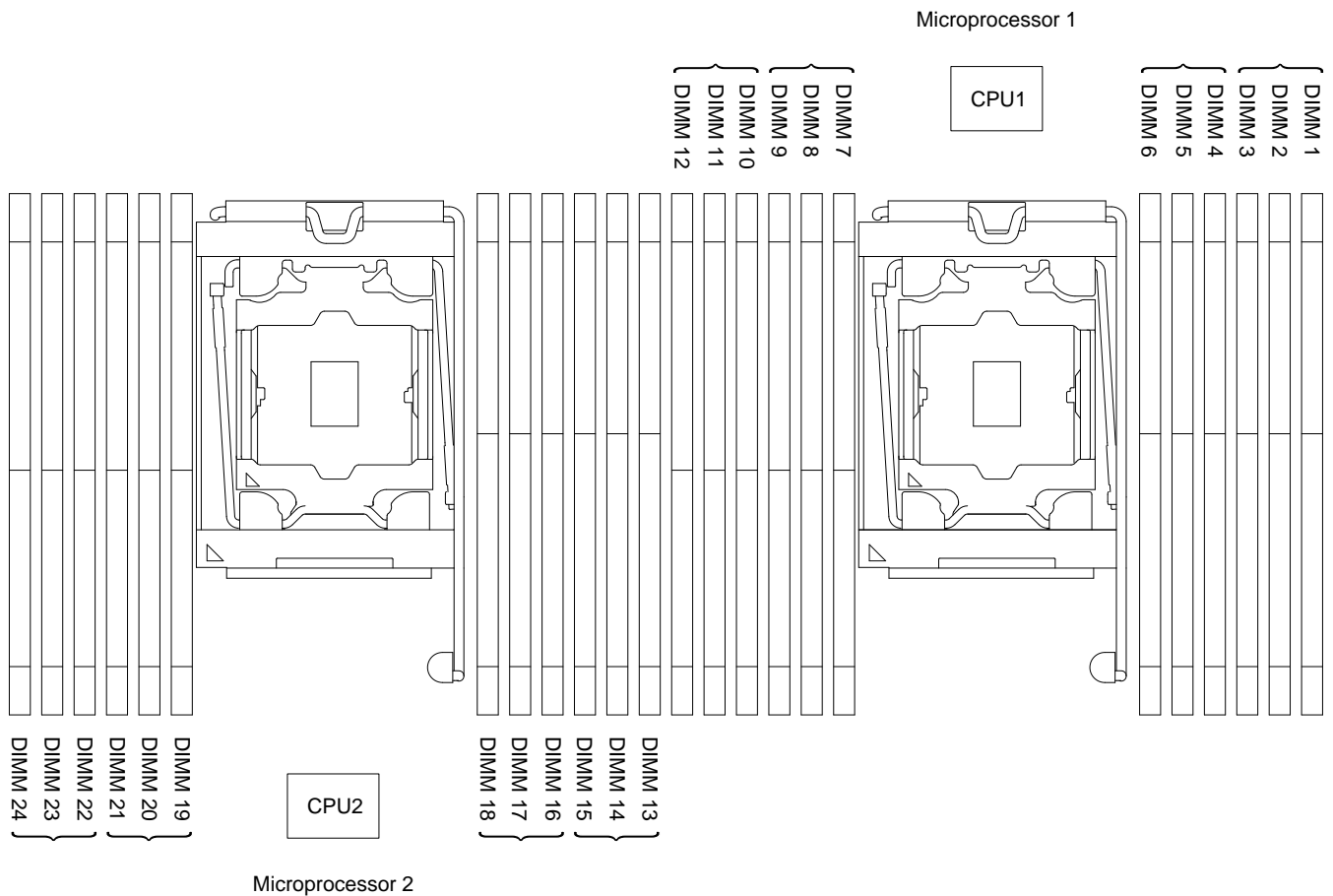

Figure 96. DIMM connectors location

### DIMM installation sequence

Depending on the server model, the server may come with a minimum of one 4 GB DIMM installed in slot 1. When you install additional DIMMs, install them in the order shown in the following table to optimize system performance.

In general, all four channels on the memory interface for each microprocessor can be populated in any order and have no matching requirements.

Table 12. Normal mode DIMM installation sequence

Number of installed microprocessor	DIMM connector population sequence
One microprocessor installed	1, 4, 9, 12, 2, 5, 8, 11, 3, 6, 7, 10
Two microprocessors installed	1, 13, 4, 16, 9, 21, 12, 24, 2, 14, 5, 17, 8, 20, 11, 23, 3, 15, 6, 18, 7, 19, 10, 22

For optimal performance:

Make sure all four memory channels of each microprocessor are populated. Each memory channels should be populated with the same type and amount of memory per channel. Each microprocessor socket should be populated with the same type and amount of memory per socket. 1DPC (one DIMM per channel) or 2DPC (two DIMM per channel) memory configuration are recommended. Unless there is a need for memory

capacity over memory frequency, 3DPC (three DIMMs per channel) configuration is not recommended since 3DPC configuration forces the memory subsystem to run at a lower frequency (1600 MHz).

Refer to the [Understanding and Optimizing Memory Performance for Intel Xeon Processor E5-2600 v3 Series in IBM Flex System, System x, and BladeCenter Platforms](#) white paper for the detail.

## Memory mirrored channel

Memory mirrored channel mode replicates and stores data on two pairs of DIMMs within two channels simultaneously.

If a failure occurs, the memory controller switches from the primary pair of memory DIMMs to the backup pair of DIMMs. To enable memory mirrored channel through the Setup Utility, select **System Settings** → **Memory**. For more information, see “Using the Setup Utility” on page 47. When you use the memory mirrored channel feature, consider the following information:

- When you use memory mirrored channel, you must install a pair of DIMMs at a time. The two DIMMs in each pair must be identical in size, type, and rank (single, dual, or quad), and organization, but not in speed. The channels run at the speed of the slowest DIMM in any of the channels.
- The maximum available memory is reduced to half of the installed memory when memory mirrored channel is enabled. For example, if you install 64 GB of memory using RDIMMs, only 32 GB of addressable memory is available when you use memory mirrored channel.

The following diagram lists the DIMM connectors on each memory channel.

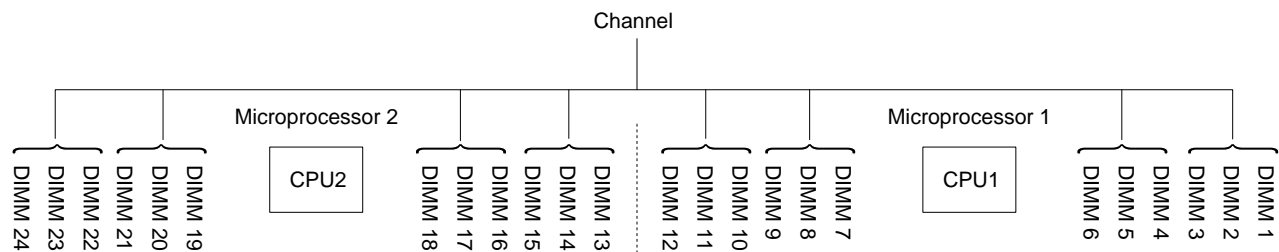

Figure 97. Connectors on each memory channel

The following table shows the installation sequence for memory mirrored channel mode:

Table 13. Memory mirrored channel mode DIMM population sequence

Number of installed microprocessors	DIMM connector population sequence
1	1, 4
	9, 12
	2, 5
	8, 11
	3, 6
	7, 10
2	1, 4
	13, 16
	9, 12
	21, 24

Table 13. Memory mirrored channel mode DIMM population sequence (continued)

Number of installed microprocessors	DIMM connector population sequence
	2, 5
	14, 17
	8, 11
	20, 23
	19, 22
	3, 6
	15, 18
	7, 10

### Memory rank sparing

The memory rank sparing feature disables the failed memory from the system configuration and activates a rank sparing DIMM to replace the failed active DIMM.

You can enable rank sparing memory in the Setup Utility, select **System Settings → Memory**. For more information, see “Using the Setup Utility” on page 47. When you use the memory rank sparing feature, consider the following information:

- The memory rank sparing feature is supported on server models with an Intel Xeon™ E5-2600 v4 series microprocessor.
- The maximum available memory is reduced when memory rank sparing mode is enabled.

The following diagram lists the DIMM connectors on each memory channel.

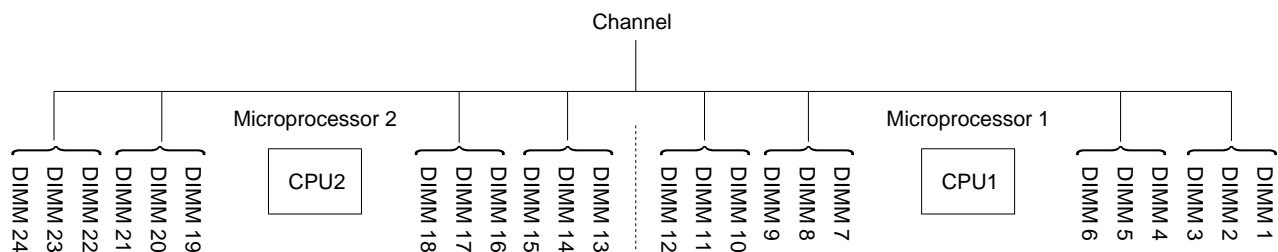

Figure 98. Connectors on each memory channel

Follow the installation sequence for rank sparing mode:

- Install at least two single-rank or dual-rank DIMMs in a channel.

Table 14. Memory rank sparing mode DIMM population sequence

Number of DIMMs	Number of installed microprocessor	DIMM connector
First pair of DIMMs	1	1, 2
Second pair of DIMMs	1	4, 5
Third pair of DIMMs	1	8, 9
Fourth pair of DIMMs	1	11, 12

Table 14. Memory rank sparing mode DIMM population sequence (continued)

Number of DIMMs	Number of installed microprocessor	DIMM connector
Fifth pair of DIMMs	1	3, 6
Sixth pair of DIMMs	1	7, 10
Seventh pair of DIMMs	1	13, 14
Eighth pair of DIMMs	1	16, 17
Ninth pair of DIMMs	1	20, 21
Tenth pair of DIMMs	1	23, 24
Eleventh pair of DIMMs	1	15, 18
Twelfth pair of DIMMs	1	19, 22

## Replacing a memory module

Use this information to replace a memory module.

- Step 1. Read the safety information that begins on “Safety” on page v and “Installation guidelines” on page 287.
- Step 2. Turn off the server and peripheral devices and disconnect the power cords and all external cables, if necessary.
- Step 3. Remove the top cover (see “Removing the top cover” on page 144).
- Step 4. Remove the air baffle (see “Removing the air baffle” on page 147).
- Step 5. Carefully open the retaining clips on each end of the DIMM connector and remove the DIMM.

**Attention:** To avoid breaking the retaining clips or damaging the DIMM connectors, open and close the clips gently.

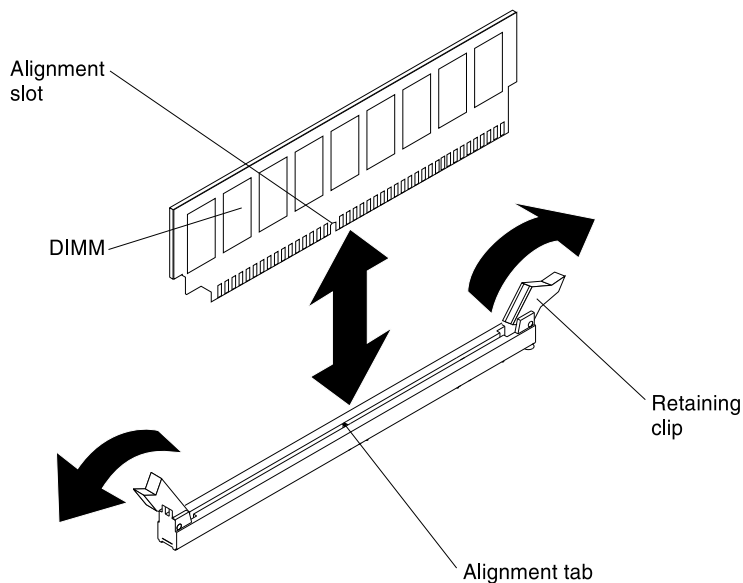

Figure 99. DIMM installation

- Step 6. Touch the static-protective package that contains the DIMM to any unpainted metal surface on the outside of the server. Then, remove the DIMM from the package.
- Step 7. Turn the DIMM so that the alignment slot align correctly with the alignment tab.
- Step 8. Insert the DIMM into the connector by aligning the edges of the DIMM with the slots at the ends of the DIMM connector (see “System-board optional-device connectors” on page 29 for the locations of the DIMM connectors).
- Step 9. Firmly press the DIMM straight down into the connector by applying pressure on both ends of the DIMM simultaneously. The retaining clips snap into the locked position when the DIMM is firmly seated in the connector.

**Note:** If there is a gap between the DIMM and the retaining clips, the DIMM has not been correctly inserted; open the retaining clips, remove the DIMM, and then reinsert it.

- Step 10. Reconnect the power cords and any cables that you removed.
- Step 11. Replace the air baffle (see “Replacing the air baffle” on page 148).

**Note:** Close all the retaining clips even for slots without DIMMs installed before replacing the air baffle.

- Step 12. Replace the top cover (see “Replacing the top cover” on page 146).
- Step 13. Turn on the peripheral devices and the server.

## Removing the fan cage assembly

Use this information to remove the fan cage assembly.

To replace some components or to create working room, you might have to remove the fan cage assembly.

**Note:** To remove or install a fan, it is not necessary to remove the fan cage. See “Removing a hot-swap fan” on page 174 and “Replacing a hot-swap fan” on page 175.

To remove the fan cage assembly, complete the following steps:

- Step 1. Read the safety information that begins on “Safety” on page v and “Installation guidelines” on page 287.
- Step 2. Turn off the server and peripheral devices and disconnect the power cords and all external cables.
- Step 3. Remove the top cover (see “Removing the top cover” on page 144).
- Step 4. **1** Lift the fan cage assembly release latches and rotate the release latches up until the fan cage assembly disengages from the chassis; **2** then, lift the fan cage assembly out of the server.



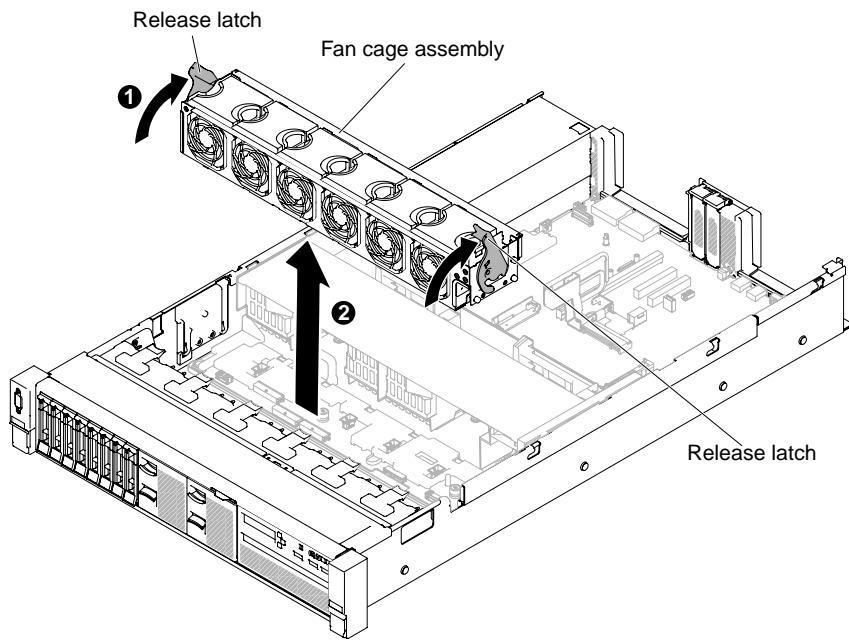

Figure 100. Fan cage assembly removal

- Step 5. If you are instructed to return the fan cage assembly, follow all of the packaging instructions, and use any packaging materials for shipping that are supplied to you.

## Replacing the fan cage assembly

Use this information to replace the fan cage assembly.

To install the fan cage assembly, complete the following steps:

- Step 1. Read the safety information that begins on “Safety” on page v and “Installation guidelines” on page 287.
- Step 2. Turn off the server and peripheral devices and disconnect all power cords.
- Step 3. Remove the top cover (see “Removing the top cover” on page 144).
- Step 4. **1** Align the pins on the fan cage assembly with the slots on both sides of the chassis and lower it into the server.
- Step 5. **2** Rotate the fan cage assembly release latches down until the release latches are in the locked position and make sure the assembly is correctly seated into place.

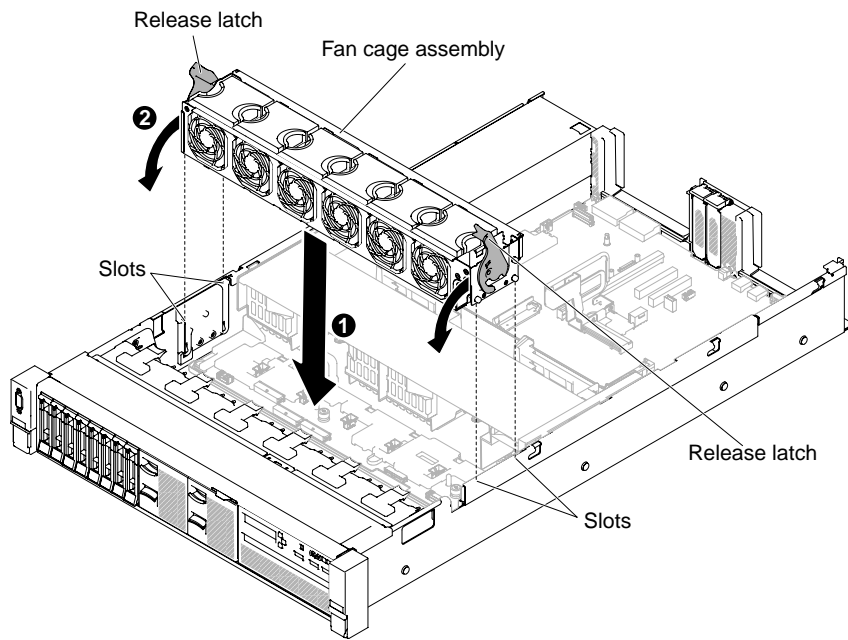

Figure 101. Fan cage assembly installation

- Step 6. Replace the fans, if needed (see “Replacing a hot-swap fan” on page 175).
- Step 7. Replace the top cover (see “Replacing the top cover” on page 146).
- Step 8. Slide the server into the rack.
- Step 9. Reconnect the power cords and any cables that you removed.
- Step 10. Turn on the peripheral devices and the server.

## Removing a hot-swap fan

Use this information to remove a hot-swap fan.

**Attention:** To ensure proper server operation, replace a failed hot-swap fan within 30 seconds.

To remove a hot-swap-fan, complete the following steps:

- Step 1. Read the safety information that begins on “Safety” on page v and “Installation guidelines” on page 287.
- Step 2. Remove the top cover (see “Removing the top cover” on page 144). The LED on the system board near the connector for the failing single-motor hot-swap fan will be lit.

**Attention:** It is not necessary to disconnect the power when removing the hot-swap fan. To ensure proper system cooling, do not remove the top cover for more than 30 minutes during this procedure.

- Step 3. **1** Pull the fan latch to the left to release the fan from the fan connector and **2** pull the fan out of the fan cage.

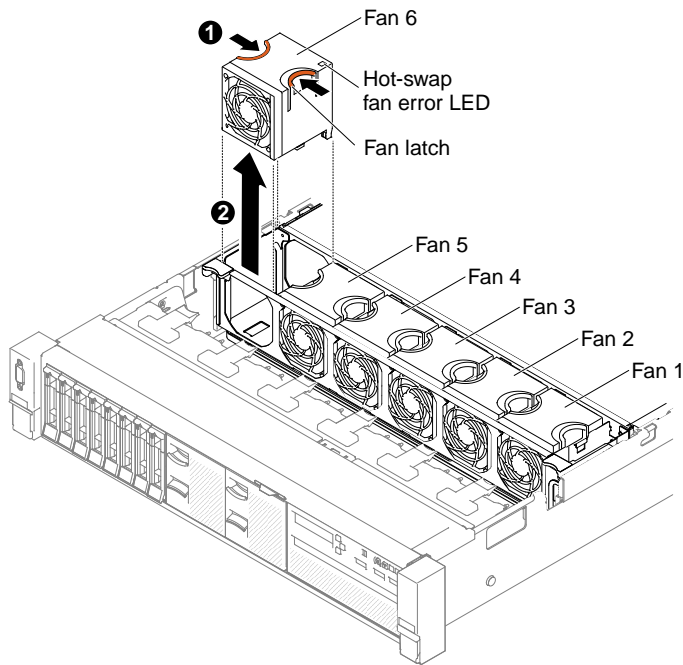

Figure 102. Fan removal

**Attention:** To ensure proper operation, replace a failed hot-swap fan within 30 seconds.

Step 4. If you are instructed to return the fan, follow all of the packaging instructions, and use any packaging materials for shipping that are supplied to you.

## Replacing a hot-swap fan

Use this information to replace a hot-swap fan.

For proper cooling, the server requires that all four single-motor hot-swap fans be installed at all times.

**Attention:** To ensure proper operation, replace a failed hot-swap fan within 30 seconds.

To replace a hot-swap fan, complete the following steps:

- Step 1. Read the safety information that begins on “Safety” on page v and “Installation guidelines” on page 287.
- Step 2. Remove the top cover (see “Removing the top cover” on page 144).
- Step 3. Touch the static-protective package that contains the new fan to any unpainted metal surface on the server. Then, remove the new fan from the package.
- Step 4. Orient the fan over the fan slot in the fan cage so that the fan connector aligns with the connector on the system board.
- Step 5. Insert the fan into the fan slot in the fan cage and press it down until it is seated correctly in the slot.

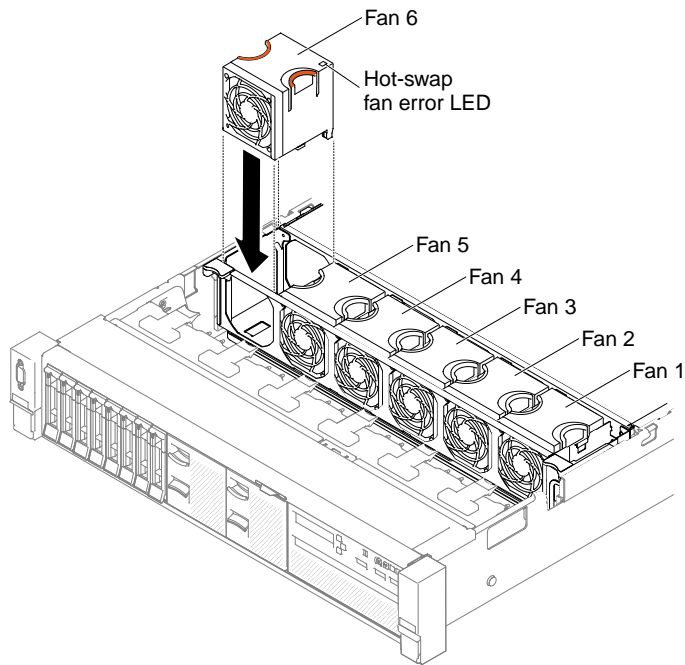

Figure 103. Fan installation

**Note:** Make sure that the newly-installed fan aligns horizontally with other correctly-seated fans for proper installation.

- Step 6. Replace the top cover (see “Replacing the top cover” on page 146).
- Step 7. Slide the server into the rack.

## Removing the media cage (also called lightpath LCD operation panel assembly)

Use this information to remove the media cage (also called lightpath LCD operation panel assembly).

To remove the media cage, complete the following steps:

- Step 1. Read the safety information that begins on “Safety” on page v and “Installation guidelines” on page 287.
- Step 2. Turn off the server and peripheral devices and disconnect the power cords and all external cables, if necessary.
- Step 3. Remove the top cover (see “Removing the top cover” on page 144).
- Step 4. Disconnect the front USB, DVD drive and operator information panel/LCD panel cables from the system board. Remember the relevant cable routing.

**Note:** To disconnect the operator information/LCD panel cable, press evenly on the connector first; then, pull the cable out.

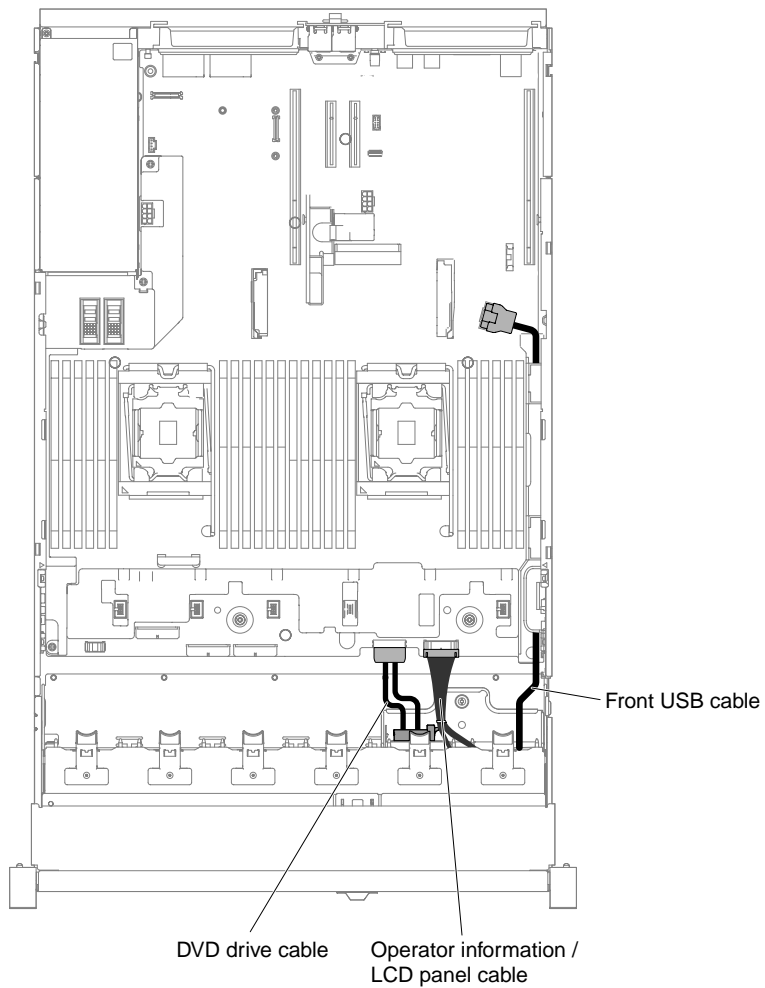

Figure 104. Cable routing

Step 5. Loosen the thumbscrew that is used to secure the media cage onto the server.

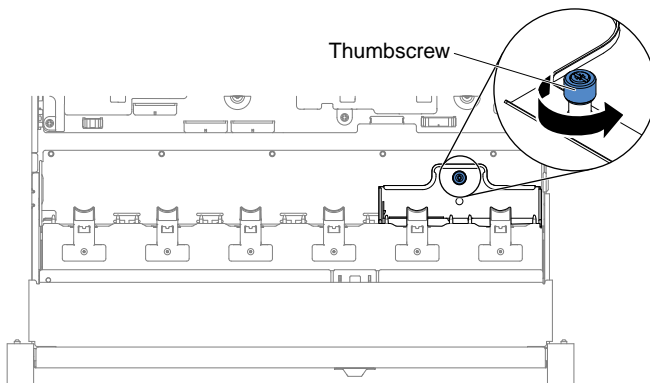

Figure 105. Thumbscrew

Step 6. Carefully push the media cage out of the server and set it aside.

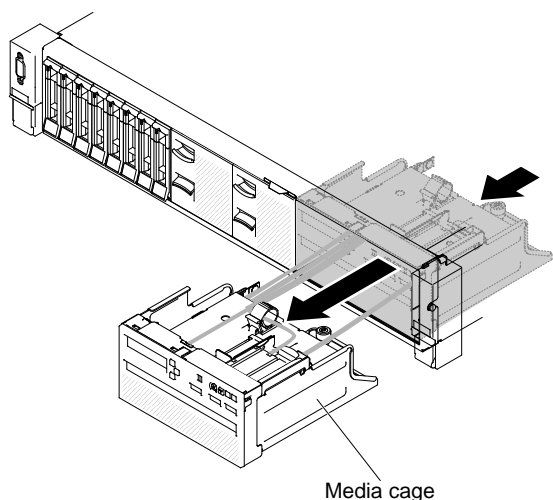

Figure 106. Media cage removal

Step 7. If you are instructed to return the media cage, follow all of the packaging instructions, and use any packaging materials for shipping that are supplied to you.

## Replacing the media cage (also called lightpath LCD operation panel assembly)

Use this information to replace the media cage (also called lightpath LCD operation panel assembly).

To install the media cage, complete the following steps:

- Step 1. Read the safety information that begins on “Safety” on page v and “Installation guidelines” on page 287.
- Step 2. Turn off the server and peripheral devices and disconnect all power cords.
- Step 3. Remove the top cover (see “Removing the top cover” on page 144).
- Step 4. Carefully slide the media cage into the server.

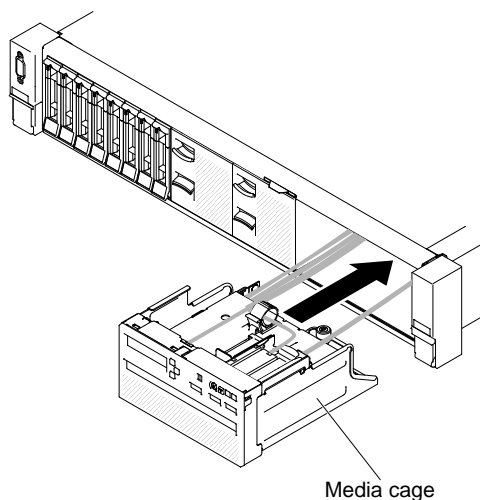

Figure 107. Media cage installation

Step 5. Tighten the thumbscrew to secure the media cage onto the server.

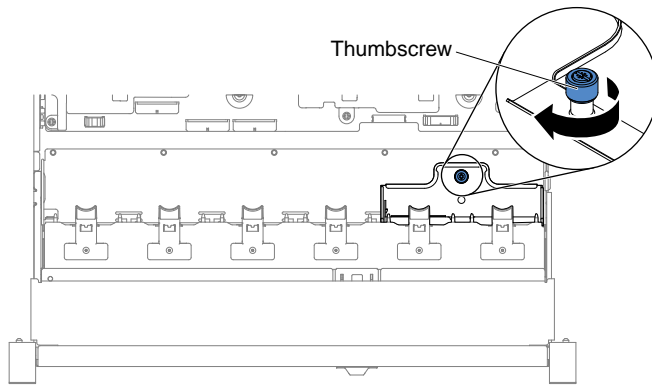

Figure 108. Thumbscrew

Step 6. Reconnect the USB, CD/DVD and operator information/LCD panel cables to the system board first; then, route the cables as the following illustration. Remember to insert the cables into the cable clip for proper routing.

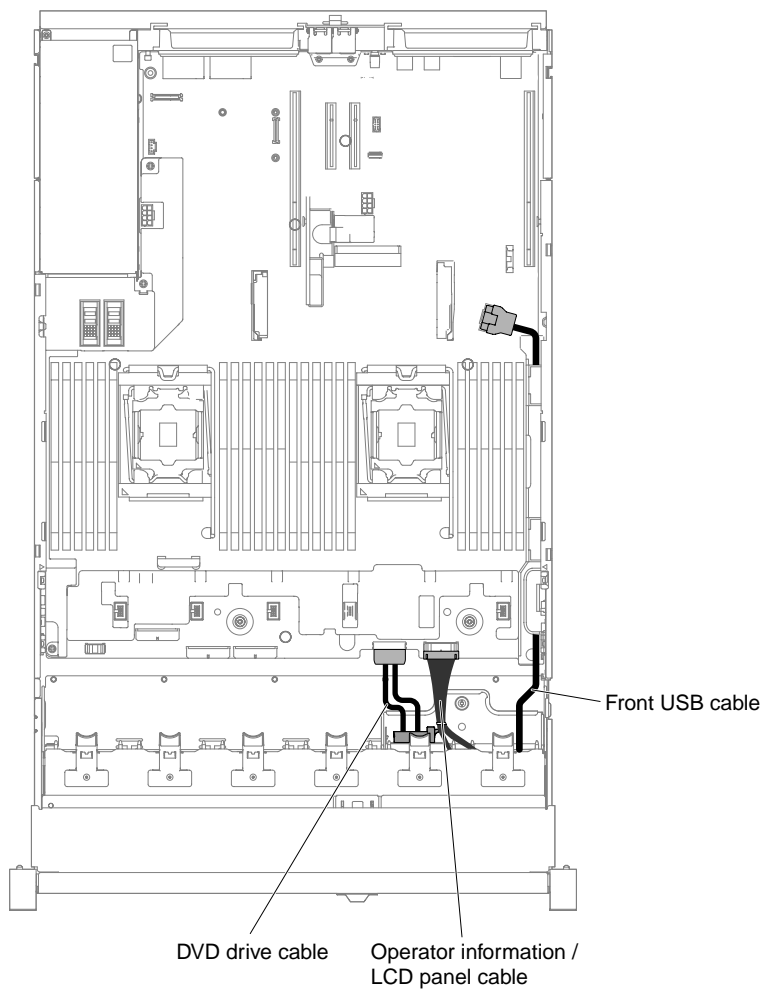

Figure 109. Cable routing

- Step 7. Replace the top cover (see “Replacing the top cover” on page 146).
- Step 8. Slide the server into the rack.

Step 9. Reconnect the power cords and any cables that you removed.

Step 10. Turn on the peripheral devices and the server.

## Removing a riser-card assembly

Use this information to remove a riser-card assembly.

See <http://www.lenovo.com/serverproven/> for a list of riser-card assemblies that you can use with the server.

To remove a riser-card assembly, complete the following steps:

Step 1. Read the safety information that begins on page “Safety” on page v and “Installation guidelines” on page 287.

Step 2. Turn off the server and peripheral devices, and disconnect the power cord and all external cables.

Step 3. Remove the top cover (see “Removing the top cover” on page 144).

Step 4. Grasp the blue touch-points on the front and the rear side of the riser-card assembly; then, lift it up to remove it from the server. Place the riser-card assembly on a flat, static-protective surface.

- For half-length and low profile adapters

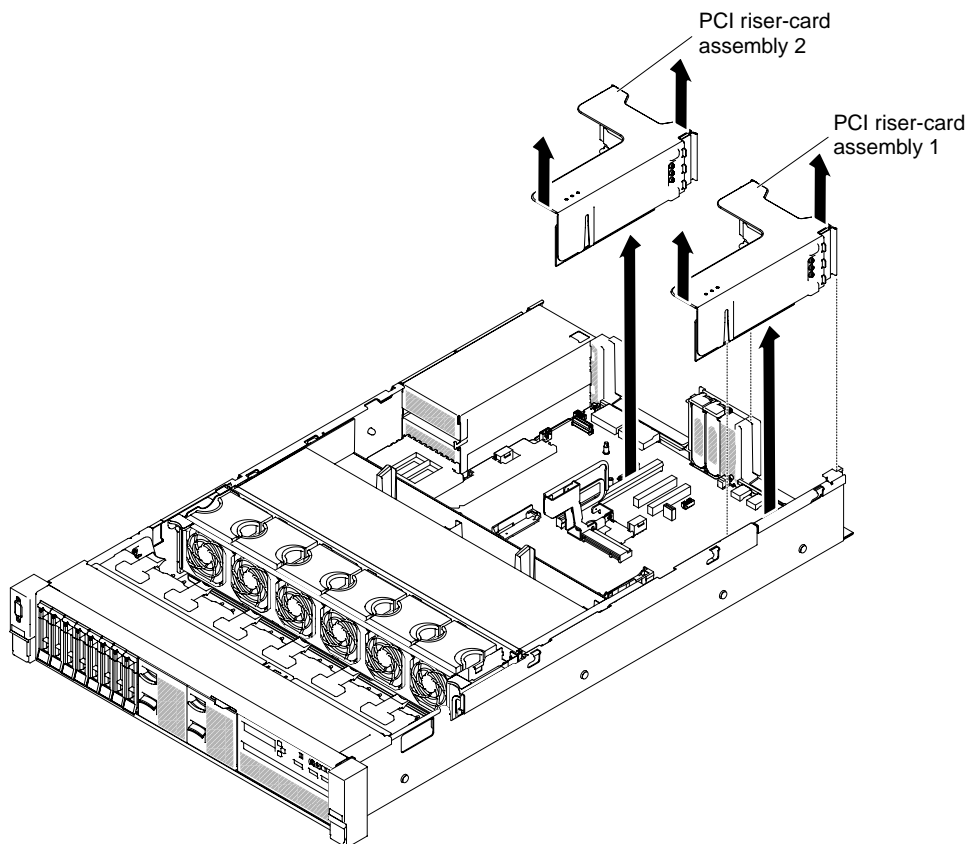

Figure 110. Riser-card assembly removal - half-length and low profile adapters

- For full-height, full-length adapters



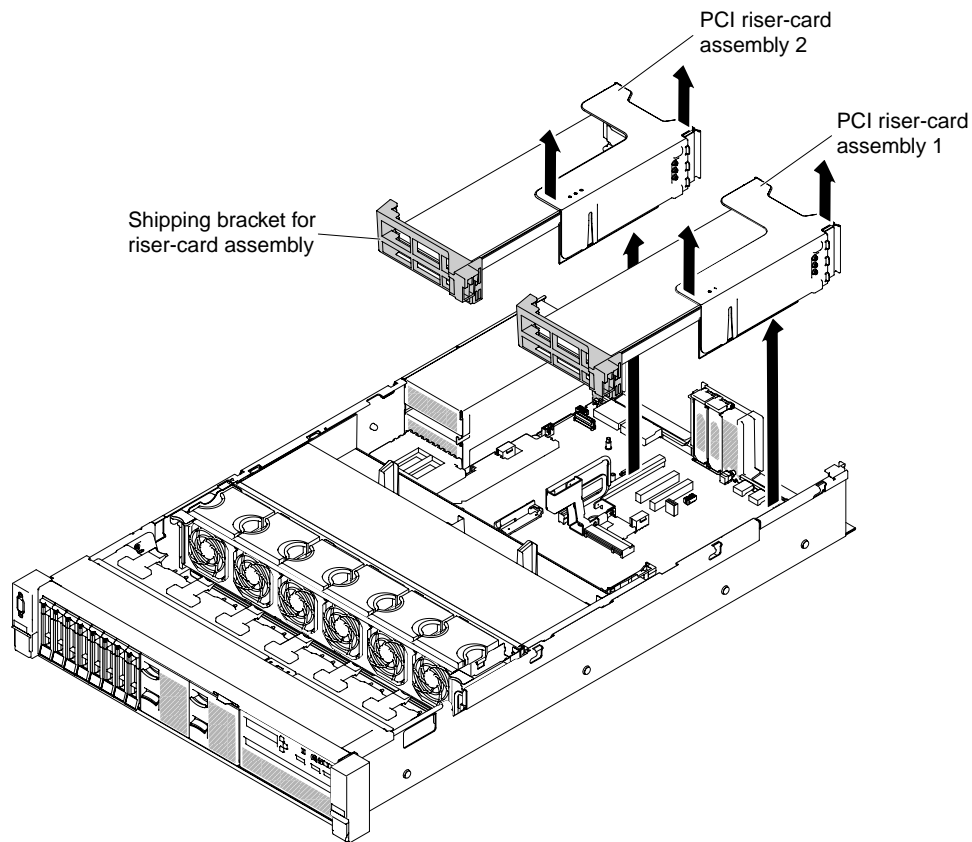

Figure 111. Riser-card assembly removal - full-height, full-length adapters

Step 5. If you are instructed to return the riser-card assembly, follow all of the packaging instructions, and use any packaging materials for shipping that are supplied to you.

## Replacing a riser-card assembly

Use this information to replace a riser-card assembly.

The server provides two riser-card slots on the system board. The following information indicates the riser-card slots:

- PCI riser slot 1 (the farthest slot from the power supplies). You must install a riser-card assembly in slot 1 with microprocessor 1.
- PCI riser slot 2 (the closest slot to the power supplies). You must install a riser-card assembly in slot 2 with microprocessor 2.
- PCI riser-card brackets must be installed even if you do not install an adapter.

To install a riser-card assembly, complete the following steps:

- Step 1. Read the safety information that begins on “Safety” on page v and “Installation guidelines” on page 287.
- Step 2. Turn off the server and peripheral devices and disconnect all power cords.
- Step 3. Remove the top cover (see “Removing the top cover” on page 144).
- Step 4. Reinstall any adapters and reconnect any internal cables you might have removed in other procedures (see “Replacing an adapter” on page 189 and “Internal cable routing and connectors” on page 131).

Step 5. Align the riser-card assembly with the selected PCI connector on the system board and align it with the slots on the chassis; then, lower it into the server and press down firmly until the riser-card assembly is seated correctly in the connector on the system board.

- For half-length and low profile adapters

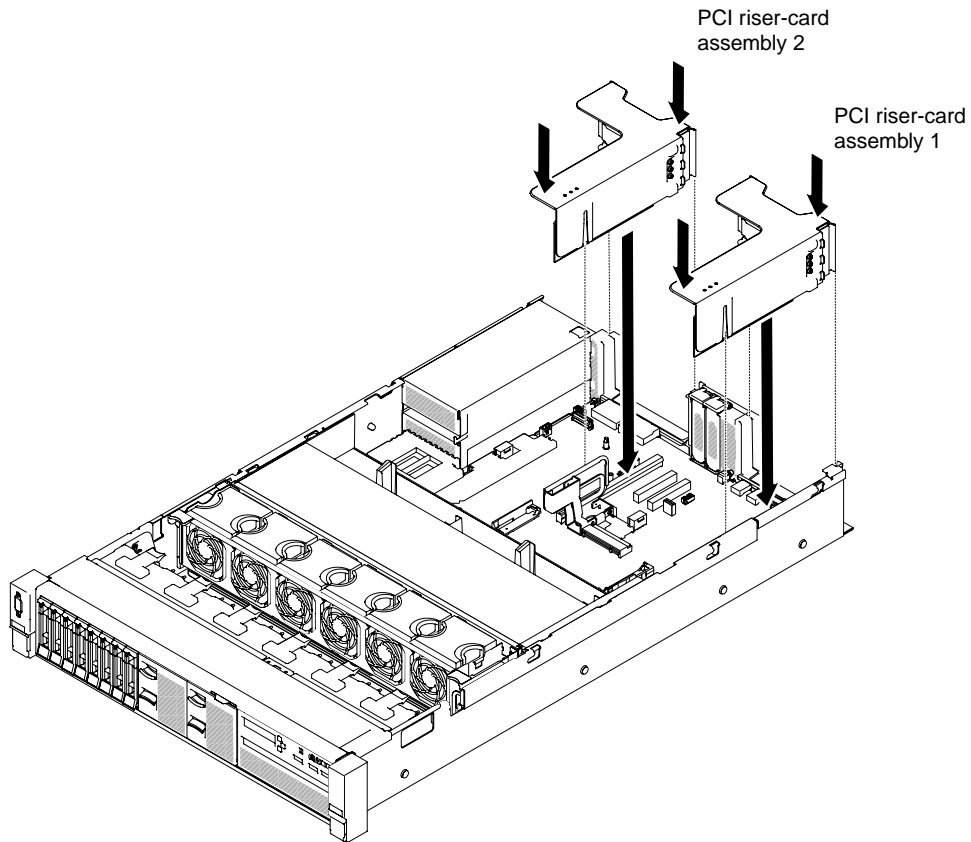

Figure 112. Riser-card assembly installation - half-length and low profile adapters

- For full-height, full-length adapters

**Note:** Shipping brackets are only included in the server that is pre-configured with full-height, full-length adapters

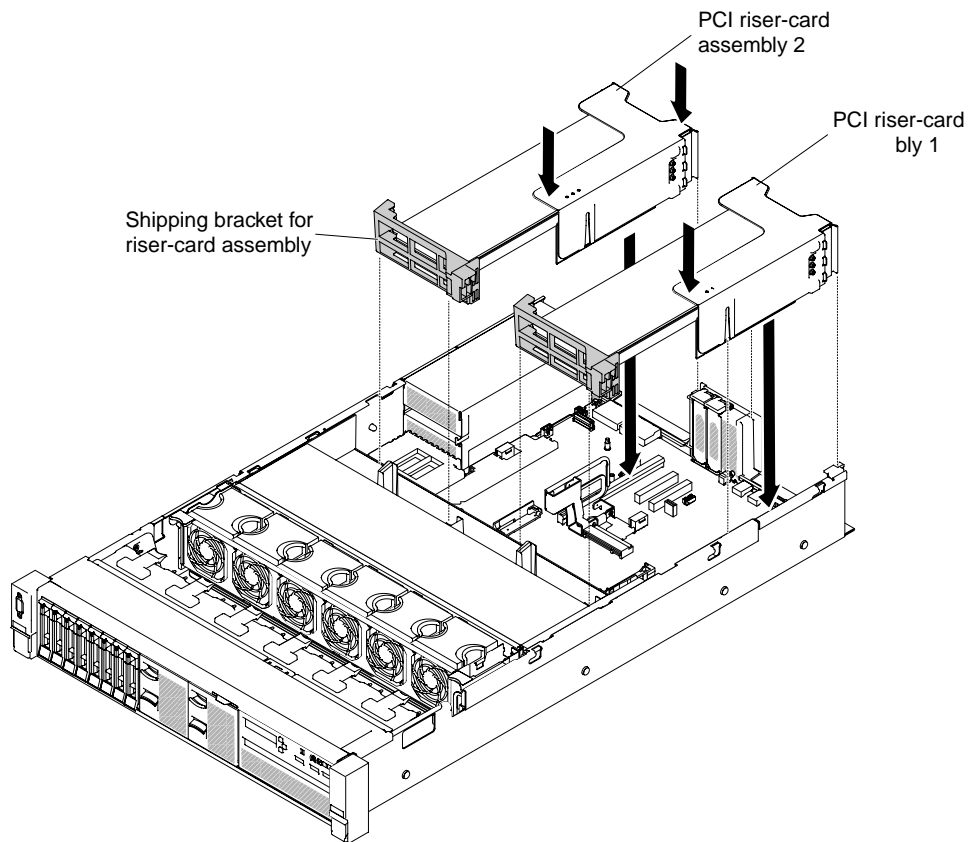

Figure 113. Riser-card assembly installation - full-height, full-length adapters

- Step 6. Replace the top cover (see “Replacing the top cover” on page 146).
- Step 7. Slide the server into the rack.
- Step 8. Reconnect the power cords and any cables that you removed.
- Step 9. Turn on the peripheral devices and the server.

## Removing the dedicated slotless RAID controller

Use this information to remove the dedicated slotless RAID controller.

The dedicated slotless RAID controller can be installed in the dedicated connector on the system board (see “System-board internal connectors” on page 28 for the location of the connectors).

To remove the dedicated slotless RAID controller, complete the following steps:

- Step 1. Read the safety information that begins on “Safety” on page v and “Installation guidelines” on page 287.
- Step 2. Turn off the server and peripheral devices and disconnect the power cords and all external cables, if necessary.
- Step 3. Remove the top cover (see “Removing the top cover” on page 144).
- Step 4. Disconnect the signal cables from the connectors on the controller and note their locations.
- Step 5. **1** Press the retention tabs away from the controller; then, slightly lift up the rear of the controller, and **2** pull it out of the connector on the system board.

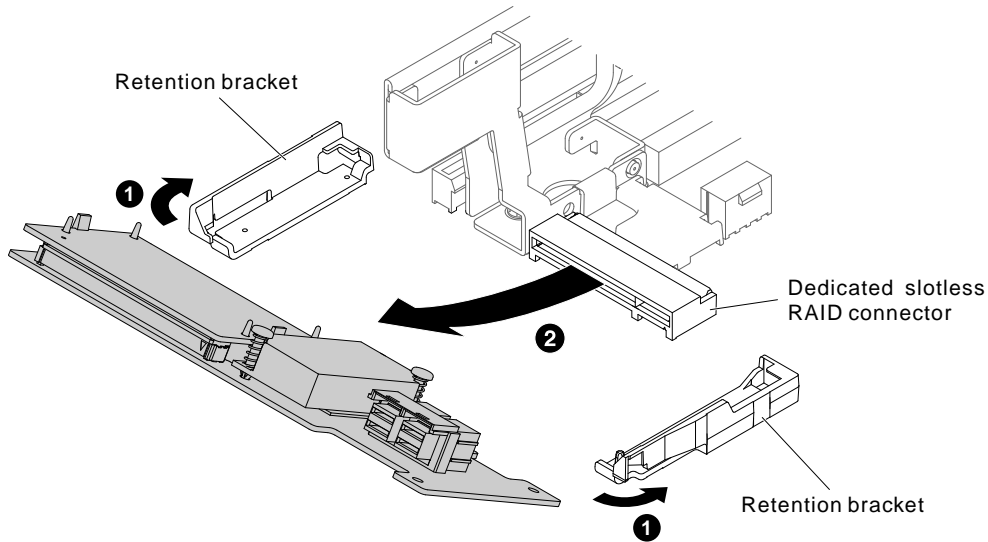

Figure 114. Dedicated slotless RAID controller removal

Step 6. If you are instructed to return the dedicated slotless RAID controller, follow all of the packaging instructions, and use any packaging materials for shipping that are supplied to you.

## Replacing the dedicated slotless RAID controller

Use this information to replace the dedicated slotless RAID controller.

The dedicated slotless RAID controller can be installed in the dedicated connector on the system board (see “System-board internal connectors” on page 28 for the location of the connectors).

To replace the dedicated slotless RAID controller, complete the following steps:

- Step 1. Read the safety information that begins on “Safety” on page v and “Installation guidelines” on page 287.
- Step 2. Turn off the server and peripheral devices and disconnect the power cords and all external cables, if necessary.
- Step 3. Remove the top cover (see “Removing the top cover” on page 144).
- Step 4. If you are installing a new or replacement controller, touch the static-protective package that contains the new controller to any unpainted metal surface on the server. Then, remove the new controller from the package.
- Step 5. Align the controller so that the keys align correctly with the connector on the system board.
- Step 6. Insert the controller into the RAID connector on the system board until it is firmly seated. The retention brackets secure the controller in place when the controller is firmly seated into the connector.

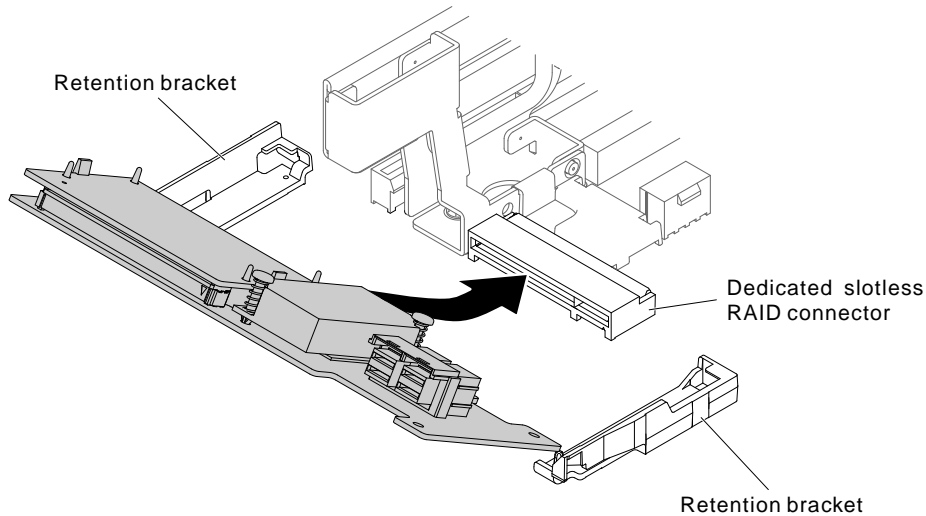

Figure 115. Dedicated slotless RAID controller installation

- Step 7. Route the backplane signal cables. (See “2.5-inch hard disk drive cable connection” on page 132 and “3.5-inch hard disk drive cable connection” on page 141).
- Step 8. Connect the signal cables to the controller.
- Step 9. Reconnect any cables that you removed.
- Step 10. Replace the top cover (see “Replacing the top cover” on page 146).
- Step 11. Slide the server into the rack.
- Step 12. Reconnect the power cords and any cables that you removed.

## Removing an adapter

Use this information to remove an adapter.

### Removing an adapter in a riser-card assembly

Use this information to remove an adapter.

This topic describes removing an adapter from a expansion slot in a riser-card assembly. These instructions apply to PCI adapters such as video graphic adapters and network adapters.

The following illustration shows the locations of the adapter expansion slots from the rear of the server.

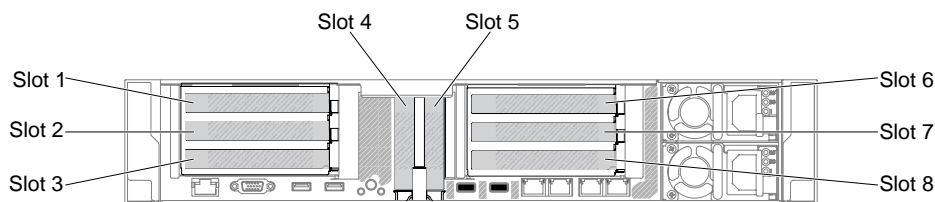

Figure 116. PCI riser-card adapter expansion slot locations

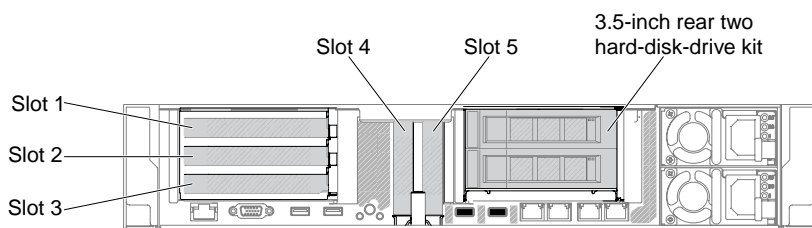

Figure 117. PCI riser-card adapter expansion slot locations

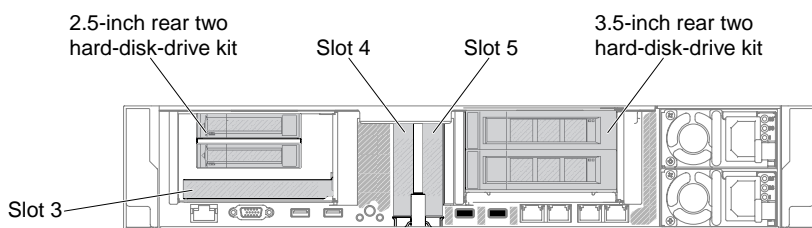

Figure 118. PCI riser-card adapter expansion slot locations

The following table describes the maximal card dimension supported in each slot.

Table 15. The maximal card dimension supported in each slot

Riser-card assembly	Slot number	The maximal card dimension supported
Riser-card assembly 1	1	Full height, up to full length
	2	Full height, up to full length
	3	Full height, half length
	4	Low-profile
	5	Low-profile
Riser-card assembly 2	6	Full height, up to full length
	7	Full height, up to full length
	8	Full height, half length

**Note:** If you are replacing a high power graphics adapter, you might need to disconnect the internal power cable from the system board before removing the adapter.

To remove an adapter, complete the following steps:

- Step 1. Read the safety information that begins on “Safety” on page v and “Installation guidelines” on page 287.
- Step 2. Turn off the server and peripheral devices and disconnect all power cords; then, remove the top cover (see “Removing the top cover” on page 144).
- Step 3. Press down on the left and right side latches and slide the server out of the rack enclosure until both slide rails lock; then, remove the top cover (see “Removing the top cover” on page 144).
- Step 4. Remove the riser-card assembly that contains the adapter (see “Removing a riser-card assembly” on page 180).
  - If you are removing an adapter from PCI expansion slot 1, 2, or 3, remove riser-card assembly 1.

- If you are removing an adapter from PCI expansion slot 6, 7 or 8, remove riser-card assembly 2.

Step 5. Disconnect any cables from the adapter (make note of the cable routing, in case you reinstall the adapter later).

Step 6. If you are removing a full-height, full-length adapter, pull the shipping bracket out of the riser-card assembly.

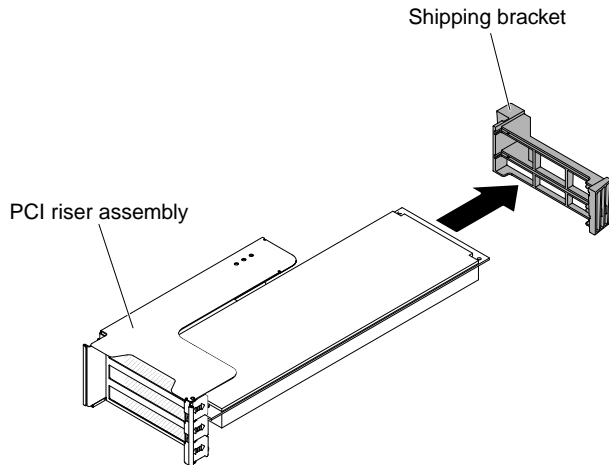

Figure 119. Full-height, full-length adapter

Step 7. 1 Slide the retention bracket; then, 2 rotate it to the open position.

Step 8. Remove the screws if present. These screws can be fastened to the side of the riser-card assembly for storage if needed.

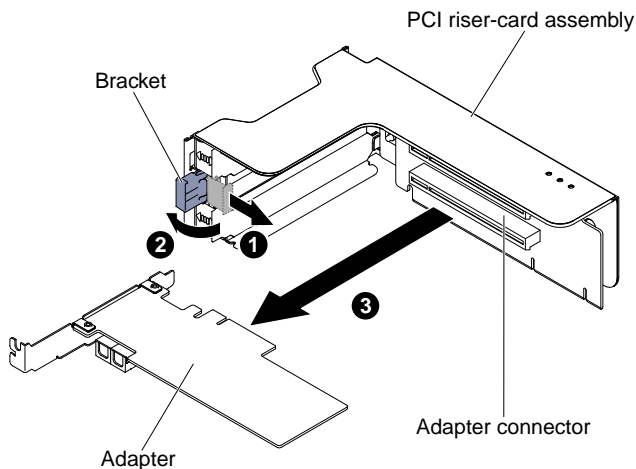

Figure 120. Adapter removal

Step 9. Carefully grasp the adapter by its top edge or upper corners, and pull the adapter from the PCI expansion slot.

Step 10. If you are instructed to return the adapter, follow all packaging instructions, and use any packaging materials for shipping that are supplied to you.

## Removing an adapter in PCI expansion slot 4 or slot 5

Use this information to remove an adapter in PCI expansion slot 4 or slot 5.

To remove an adapter in PCI expansion slot 4 or slot 5, complete the following steps:

- Step 1. Read the safety information that begins on “Safety” on page v and “Installation guidelines” on page 287.
- Step 2. Turn off the server and peripheral devices and disconnect all power cords; then, remove the top cover (see “Removing the top cover” on page 144).
- Step 3. Press down on the left and right side latches and slide the server out of the rack enclosure until both slide rails lock; then, remove the top cover (see “Removing the top cover” on page 144).
- Step 4. Disconnect any cables from the adapter (make note of the cable routing, in case you reinstall the adapter later).
- Step 5. Rotate the bracket to the open position.
- Step 6. Remove the screws if present.
- Step 7. Carefully grasp the adapter by its top edge or upper corners, and pull the adapter out of the connector.

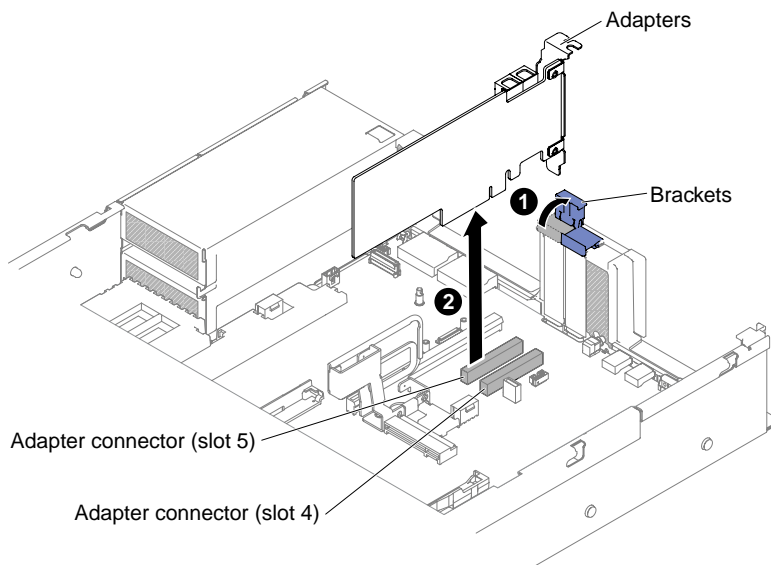

Figure 121. Adapter removal

- Step 8. If you are instructed to return the adapter, follow all packaging instructions, and use any packaging materials for shipping that are supplied to you.

## Removing an adapter in the rear two hard-disk-drive kit

Use this information to remove an adapter in the rear two hard-disk-drive kit.

To remove an adapter in the rear two hard-disk-drive kit, complete the following steps:

- Step 1. Read the safety information that begins on “Safety” on page v and “Installation guidelines” on page 287.
- Step 2. Turn off the server and peripheral devices and disconnect all power cords; then, remove the top cover (see “Removing the top cover” on page 144).
- Step 3. Press down on the left and right side latches and slide the server out of the rack enclosure until both slide rails lock; then, remove the top cover (see “Removing the top cover” on page 144).
- Step 4. Remove the rear two hard-disk-drive kit that contains the adapter (see “Removing the rear two hard-disk-drive kit” on page 200).



- If you are removing an adapter from PCI expansion slot 3, remove rear two hard-disk-drive kit 1.
  - If you are removing an adapter from PCI expansion slot 8, remove rear two hard-disk-drive kit 2.
- Step 5. Disconnect any cables from the adapter (make note of the cable routing, in case you reinstall the adapter later).
- Step 6. 1 Slide the retention bracket; then, 2 rotate it to the open position.

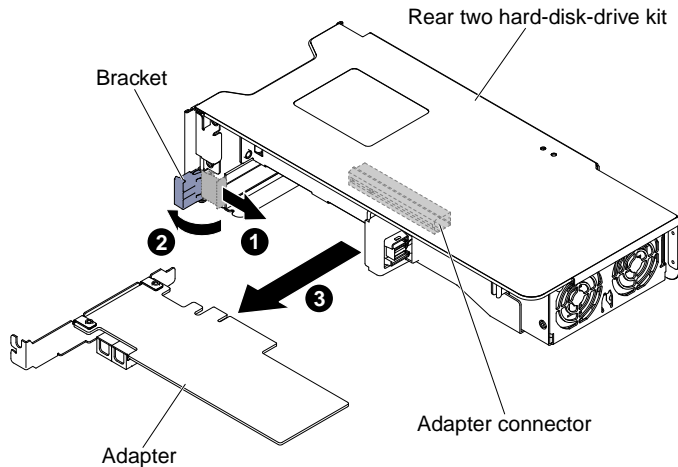

Figure 122. Adapter removal

- Step 7. Remove the screws if present. These screws can be fastened to the side of the riser-card assembly for storage if needed.
- Step 8. 3 Carefully grasp the adapter by its top edge or upper corners, and pull the adapter out of the rear two hard-disk-drive kit.
- Step 9. If you are instructed to return the adapter, follow all packaging instructions, and use any packaging materials for shipping that are supplied to you.

## Replacing an adapter

Use this information to replace an adapter.

### Notes:

- If your adapter was previously configured, backup or record its configuration information, if possible, before replacing the adapter. See the documentation for your adapter for information and instructions.
- If you are replacing a ServeRAID adapter, import your RAID configuration to the replacement adapter as a foreign configuration after you finish the replacement. See the [ServeRAID-M Software User Guide at https://support.lenovo.com/us/en/documents/migr-5086126](https://support.lenovo.com/us/en/documents/migr-5086126) for instructions.
- The following adapters support 10-Gbps transfer rate only:
  - Intel X710 2x10GbE SFP+ Adapter
  - Intel X710 ML2 4x10GbE SFP+ Adapter
  - Intel X710-DA2 ML2 2x10GbE SFP+ Adapter

## Replacing an adapter in a riser-card assembly

Use this section to replace an adapter in a riser-card assembly.

The following illustration shows the locations of the adapter expansion slots from the rear of the server.

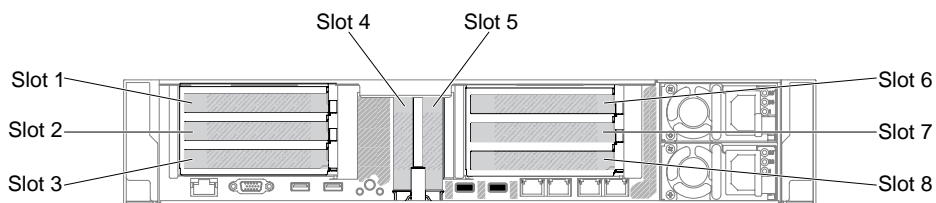

Figure 123. PCI riser-card adapter expansion slot locations

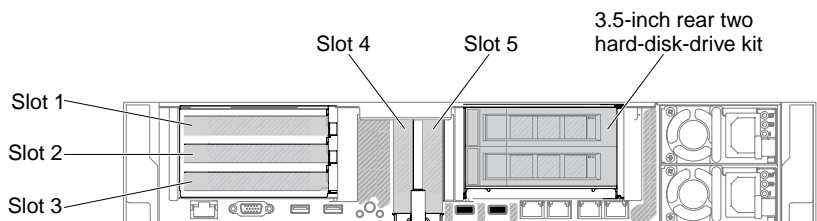

Figure 124. PCI riser-card adapter expansion slot locations

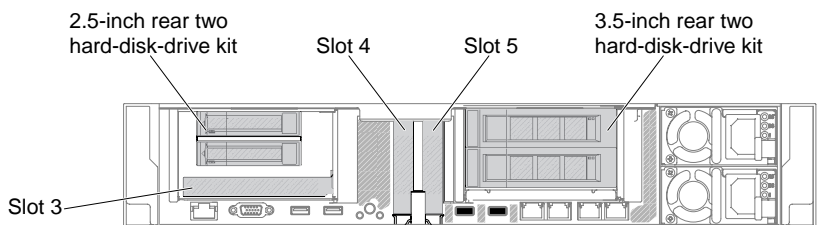

Figure 125. PCI riser-card adapter expansion slot locations

The following table describes the maximal card dimension supported in each slot.

Table 16. The maximal card dimension supported in each slot

Riser-card assembly	Slot number	The maximal card dimension supported
Riser-card assembly 1	1	Full height, up to full length
	2	Full height, up to full length
	3	Full height, half length
	4	Low-profile
	5	Low-profile
Riser-card assembly 2	6	Full height, up to full length
	7	Full height, up to full length
	8	Full height, half length

The following notes describe the types of adapters that the server supports and other information that you must consider when you install an adapter:

- Locate the documentation that comes with the adapter and follow those instructions in addition to the instructions in this section.
- The server provides two internal SAS connectors and two SAS/SATA RAID riser-card slots on the system board. See “System-board optional-device connectors” on page 29 for the location of the internal SAS/

SATA RAID connector and riser-card slots. You can replace the ServeRAID SAS/SATA adapter with an optional ServeRAID SAS/SATA adapter in the slot. For configuration information, see the ServeRAID documentation at <http://www.lenovo.com/support>.

- Do not set the maximum digital video adapter resolution above 1600 x 1200 at 75 Hz for an LCD monitor. This is the highest resolution that is supported for any add-on video adapter that you install in the server.
- Read the following table before installing memory modules when any NVIDIA adapters is installed.

Table 17. NVIDIA video adapter configurations

Description	Supported maximum total memory size
NVIDIA Grid K1 and K2	1 TB
NVIDIA Tesla K8, K40c, and M60 (Active)	1 TB
NVIDIA Quadro K420, K620, K2200, K4200, K5200, K6000, and M5000	1 TB

- Do not install the following adapters in the slot 1.

Table 18. Non-supported adapters in the slot 1

Adapter description	Option part number	FRU part number
Emulex 16Gb FC Single-port HBA for Lenovo System x	81Y1655	00D8546
Emulex 16Gb FC Dual-port HBA for Lenovo System x	81Y1662	00JY849

- Do not install the following adapters in the slot 3 and the slot 8.

Table 19. Non-supported adapters in the slot 3 and the slot 8

Adapter description	Option part number	FRU part number
N2215 SAS/SATA HBA for System x	47C8675	47C8676
N2215 SAS/SATA HBA for System x	00AE912	00AE914
ServeRAID M5225-2GB SAS/SATA Controller for System x	00AE938	00AE939
Emulex Dual Port 10GbE SFP+ VFA IIIr for System x	00D8540	00D8543
Mellanox ConnectX-3 40GbE/ FOR IB VPI Adapter for System x	00D9550	00D9552
Broadcom NetXtreme 2x10GbE Base T Adapter for System x	44T1370	00E2714
Qlogic 8200 Dual PORT 10GbE SFP + Adapter for System x	90Y4600	90Y4605
Broadcom NetXtrme Dual Port 10GbE SPG+ Adapter for System x	94Y5180	94Y5182
Mellanox ConnectX-3 10GbE Adapter for System x	00D9690	00D9692

Table 19. Non-supported adapters in the slot 3 and the slot 8 (continued)



Adapter description	Option part number	FRU part number
Intel x520 Dual Port 10GbE SFP+ Adapter for System x	49Y7960	49Y7962
Emulex VFA5 2x10GbE SFP+ Adapter for System x	00JY830	00JY833

- Any high-definition video-out connector or stereo connector on any add-on video adapter is not supported.
- When you install any PCI adapter, the power cords must be disconnected from the power source before you remove the PCI Express riser-card assembly. Otherwise, the active power management event signal will be disabled by the system-board logic, and the Wake on LAN feature might not work. However, after the server is powered-on locally, the active power manager active power management event signal will be enabled by the system-board logic.
- When you install an Intel X540 ML2 Dual Port 10GbaseT Adapter (Option part number is 00D1994), you need to install the PCIe Thermal Solution Kit (Option part number: 00MU908) first to avoid the potential thermal issue.
- Support Intel MIC GPU cards (3120A and 7120A) up to 35C/3000ft, otherwise GPU card performance could be downgraded.

**Attention:**

1. Do not install over 3 ServeRAID M1215 SAS/SATA controllers in one system.
2. Do not install the NVIDIA Grid Kx/Mxx, the NVIDIA Quadro Kxxxx or the NVIDIA Tesla Kxx adapter options in systems containing 1 TB of system memory or more. If these options are installed in systems with 1 TB of memory or more, it might cause undetected data corruption and system instability. These options are only supported in systems containing less than 1 TB of memory. For more information, go to <https://support.lenovo.com/us/en/documents/migr-5096047>.

To replace an adapter, complete the following steps:

- Step 1. Read the safety information that begins on “Safety” on page v and “Installation guidelines” on page 287.
- Step 2. Turn off the server and peripheral devices and disconnect the power cords and all external cables.
- Step 3. Remove the server top cover (see “Removing the top cover” on page 144).
- Step 4. Determine which expansion slot you will use for the adapter. If you are installing an adapter in PCI expansion slot 1, 2, or 3, remove riser-card assembly 1; if you are installing an adapter in expansion slot 6, 7, or 8, remove riser-card assembly 2. See “Removing a riser-card assembly” on page 180
- Step 5.  Slide the retention bracket; then,  rotate it to the open position.
- Step 6. Slide the expansion-slot cover out of the riser-card assembly expansion slot.
- Step 7. Align the adapter with the PCI connector on the riser card and press the adapter firmly into the PCI connector on the riser card.

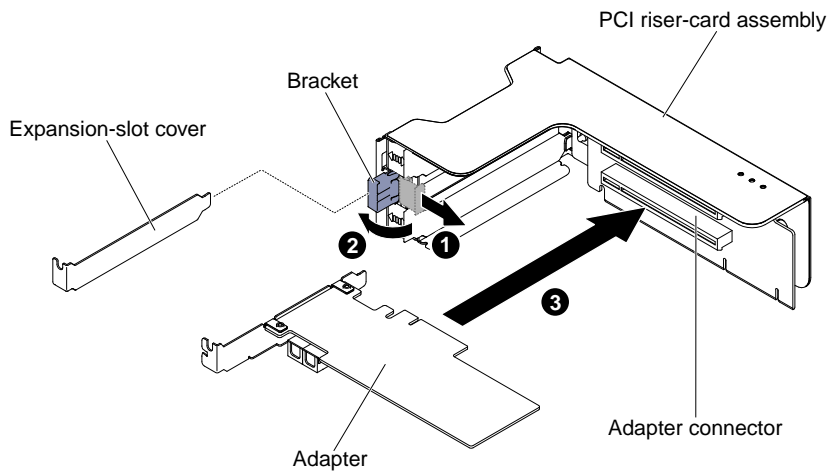

Figure 126. Adapter installation

Step 8. Rotate the retention latch to the close position.

**Note:** Fasten the screw on the retention latch to secure the adapter.

Step 9. If you are installing a full-height, full-length adapter, insert the shipping brackets.

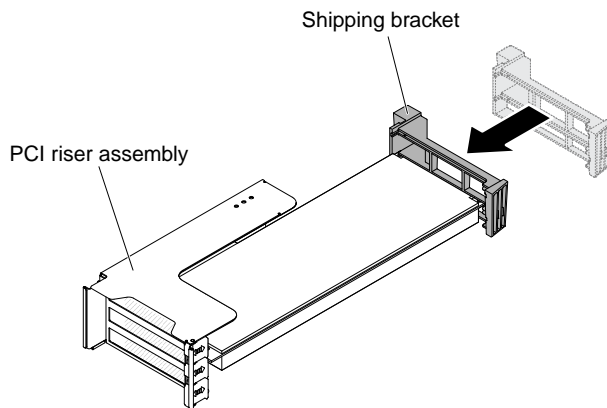

Figure 127. Full-height, full-length adapter

Step 10. Connect any required cables to the adapter.

**Attention:**

- When you route cables, do not block any connectors or the ventilated space around any of the fans.
- Make sure that cables are not routed on top of components that are under the riser-card assembly.
- Make sure that cables are not pinched by the server components.

Step 11. Align the riser-card assembly with the selected PCI connector on the system board and align it with the slots on the chassis; then, lower it into the server and press down firmly until the riser-card assembly is seated correctly in the connector on the system board.

- For half-length and low profile adapters

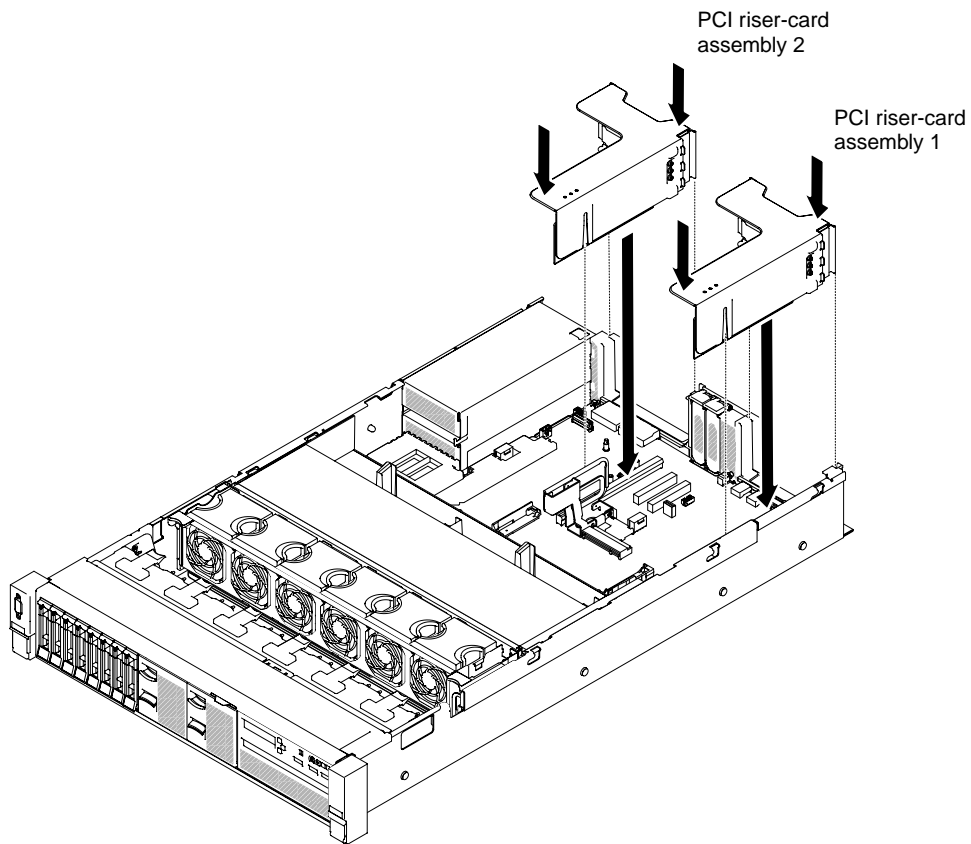

Figure 128. Riser-card assembly installation - half-length and low profile adapters

- For full-height, full-length adapters

**Note:** Shipping brackets are only included in the server that is pre-configured with full-height, full-length adapters

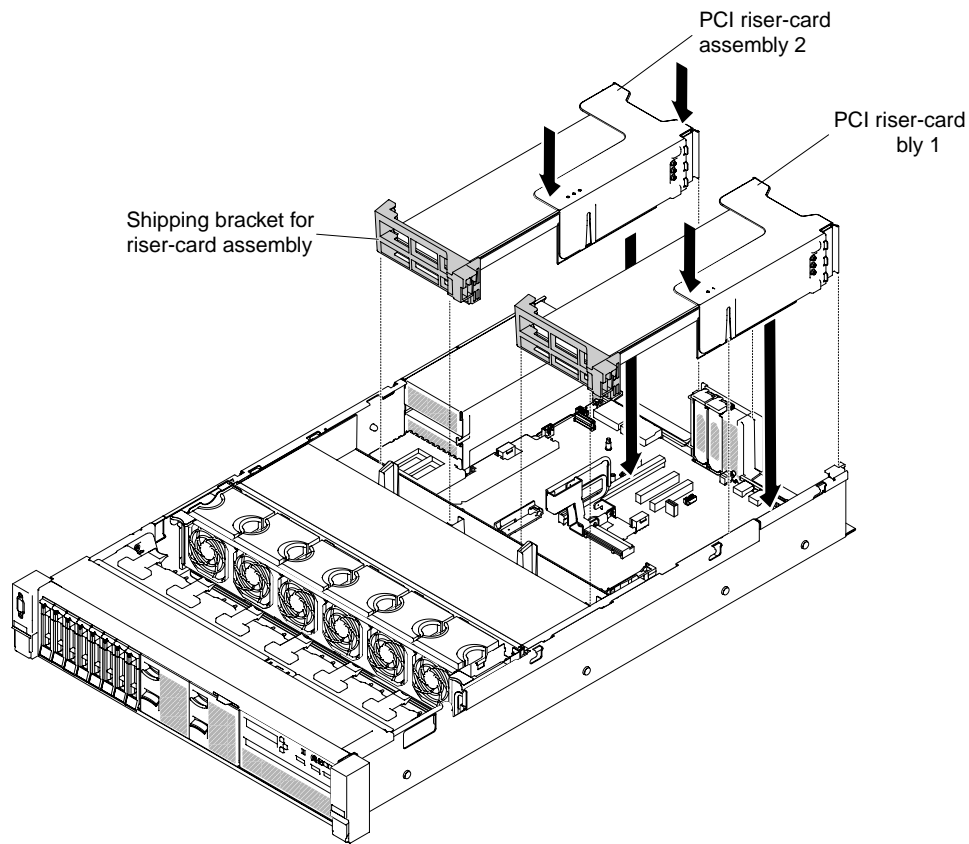

Figure 129. Riser-card assembly installation - full-height, full-length adapters

- Step 12. Perform any configuration tasks that are required for the adapter.
- Step 13. Reinstall the top cover (see “Replacing the top cover” on page 146).
- Step 14. Slide the server into the rack.
- Step 15. Reconnect the power cords and any cables that you removed.
- Step 16. Turn on the peripheral devices and the server.

### Replacing an adapter in PCI expansion slot 4 or slot 5

Use this section to replace an adapter in PCI expansion slot 4 or slot 5.

To replace an adapter, complete the following steps:

- Step 1. Read the safety information that begins on “Safety” on page v and “Installation guidelines” on page 287.
- Step 2. Turn off the server and peripheral devices and disconnect the power cords and all external cables.
- Step 3. Remove the server top cover (see “Removing the top cover” on page 144).
- Step 4. **1** Rotate the bracket to the open position.
- Step 5. Slide the expansion-slot cover out of the server.
- Step 6. **2** Align the adapter with the PCI connector on the system board and press the adapter firmly into the PCI connector on the system board.

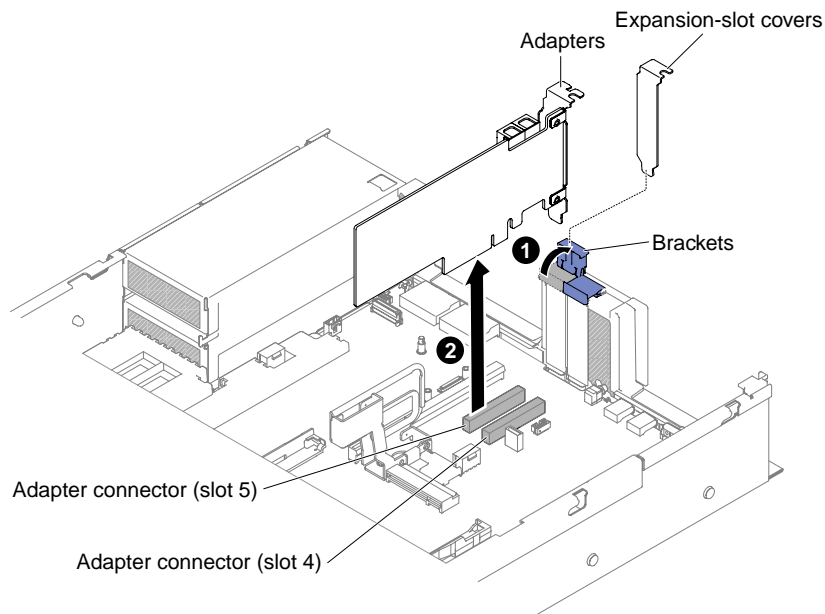

Figure 130. Adapter installation

Step 7. Rotate the retention bracket to the close position.

Step 8. Connect any required cables to the adapter.

**Attention:**

- When you route cables, do not block any connectors or the ventilated space around any of the fans.
- Make sure that cables are not routed on top of components that are under the riser-card assembly.
- Make sure that cables are not pinched by the server components.

Step 9. Perform any configuration tasks that are required for the adapter.

Step 10. Reinstall the top cover (see “Replacing the top cover” on page 146).

Step 11. Slide the server into the rack.

Step 12. Reconnect the power cords and any cables that you removed.

Step 13. Turn on the peripheral devices and the server.

### Replacing an adapter in the rear two hard-disk-drive kit

Use this information to replace an adapter in the rear two hard-disk-drive kit.

To install an adapter, complete the following steps:

Step 1. Read the safety information that begins on “Safety” on page v and “Installation guidelines” on page 287.

Step 2. Turn off the server and peripheral devices and disconnect the power cords and all external cables.

Step 3. Remove the server top cover (see “Removing the top cover” on page 144).

Step 4. Remove the rear two hard-disk-drive kit (see “Removing the rear two hard-disk-drive kit” on page 200).

Step 5. 1 Slide the retention bracket; then, 2 rotate it to the open position.

Step 6. Align the adapter with the slot on the rear two hard-disk-drive kit.



Step 7.  Press the adapter firmly into the slot on the rear two hard-disk-drive kit.

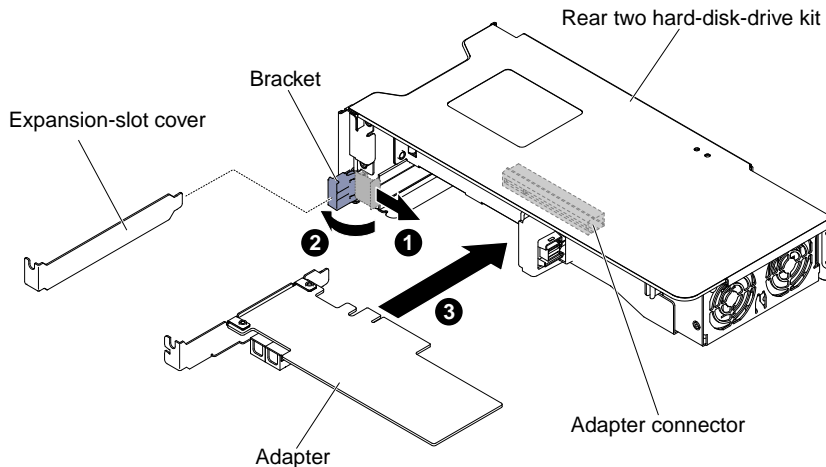

Figure 131. Adapter installation

Step 8. Connect any required cables to the adapter.

**Attention:**

- When you route cables, do not block any connectors or the ventilated space around any of the fans.
- Make sure that cables are not routed on top of components under the rear two hard-disk-drive kit.
- Make sure that cables are not pinched by the server components.

Step 9. Perform any configuration tasks that are required for the adapter.

Step 10. Replace the rear two hard-disk-drive kit in the server (see “Replacing the rear two hard-disk-drive kit” on page 201).

Step 11. Reinstall the top cover (see “Replacing the top cover” on page 146).

Step 12. Slide the server into the rack.

Step 13. Reconnect the power cords and any cables that you removed.

Step 14. Turn on the peripheral devices and the server.

## Removing a RAID adapter battery/flash power module

Use this information to remove a RAID adapter battery/flash power module.

If a RAID adapter battery / flash power module is installed near the fan cage and you need to replace it, complete the following steps:

- Step 1. Read the safety information that begins on “Safety” on page v and “Installation guidelines” on page 287.
- Step 2. Turn off the server and peripheral devices and disconnect all power cords.
- Step 3. Remove the top cover (see “Removing the top cover” on page 144).
- Step 4. Disconnect the battery/flash power module cable from the RAID adapter battery/flash power module connector.

- Step 5. If the flash power modules are located behind the full-height, full-length adapters, you need to remove the riser-card assemblies first. See “Removing an adapter in a riser-card assembly” on page 185.
- Step 6. **1** Press the release tab and **2** grasp the battery/flash power module out of the holder.

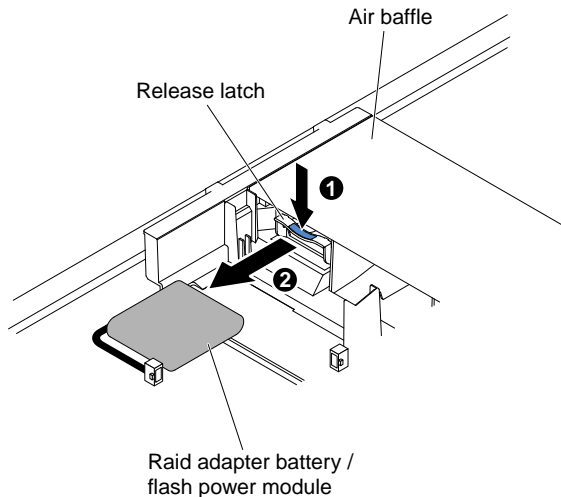

Figure 132. RAID adapter battery/flash power module removal

- Step 7. If you are instructed to return the RAID adapter battery/flash power module, follow all packaging instructions, and use any packaging materials for shipping that are supplied to you.

## Replacing a RAID adapter battery/flash power module

Use this information to replace a RAID adapter battery/flash power module.

To install a RAID adapter battery/flash power module in the server, complete the following steps:

- Step 1. Read the safety information that begins on “Safety” on page v and “Installation guidelines” on page 287.
- Step 2. Turn off the server and peripheral devices and disconnect all power cords and external devices.
- Step 3. Remove the top cover (see “Removing the top cover” on page 144).
- Step 4. Install the ServeRAID adapter on the system board (see “Replacing an adapter” on page 189) or install the ServeRAID adapter on the riser card and install the riser-card assembly in the server (see “Replacing an adapter” on page 189).
- Step 5. If the flash power modules are located behind the full-height, full-length adapters, remove the two shipping brackets first.

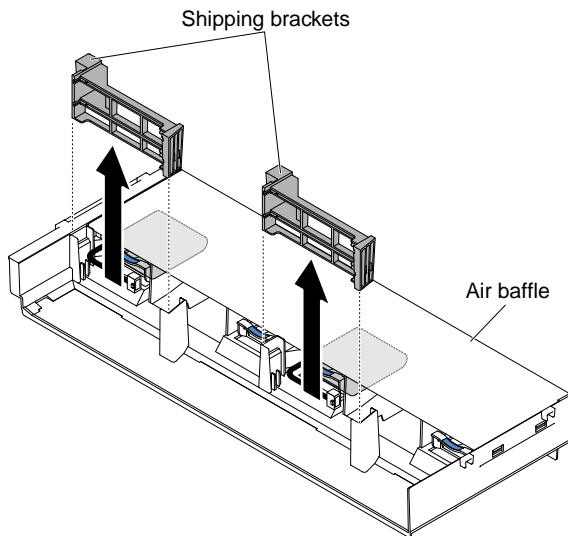

Figure 133. Shipping bracket removal

- Step 6. Align the battery/flash power module with the slot and push the battery into the battery/flash power module holder and make sure that the holder retains the battery/flash power module securely.

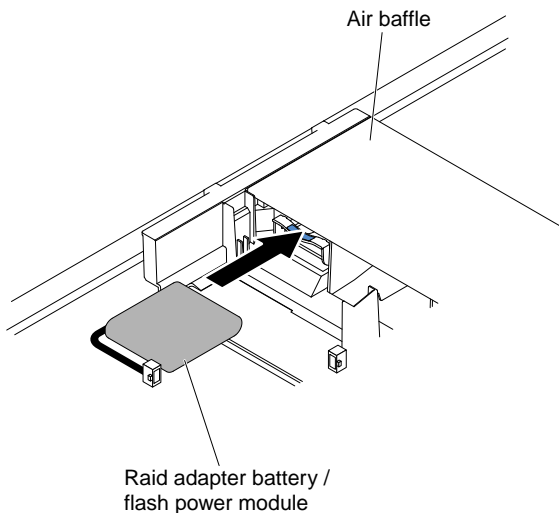

Figure 134. RAID adapter battery/flash power module installation

- Step 7. Connect the battery/flash power module cable to the RAID adapter battery/flash power module connector.

**Attention:** Make sure that the cable is not pinched and does not cover any connectors or obstruct any components on the system board.

- Step 8. Reinstall the riser-card assemblies if you have remove them. See “Replacing an adapter in a riser-card assembly” on page 189.

**Attention:**

1. Make sure that the cable is not pinched and does not cover any connectors or obstruct any components on the system board.

2. Make sure the wire cables are routed in the proper locations without blocking the retention brackets installation.

Step 9. Reinstall the top cover (see “Replacing the top cover” on page 146).

Step 10. Slide the server into the rack.

Step 11. Reconnect the power cords and all external cables, and turn on the server and peripheral devices.

## Removing the rear two hard-disk-drive kit

Use this information to remove the rear two hard-disk-drive kit.

See <http://www.lenovo.com/serverproven/> for a list of hard disk drives that you can use with the server.

To remove the rear two hard-disk-drive kit, complete the following steps:

- Step 1. Read the safety information that begins on page “Safety” on page v and “Installation guidelines” on page 287.
- Step 2. Turn off the server and peripheral devices, and disconnect the power cord and all external cables.
- Step 3. Remove the top cover (see “Removing the top cover” on page 144).
- Step 4. Grasp the kit at the front and the rear edge and lift it up to remove from the server. Place the kit on a flat, static-protective surface.

- 2.5-inch rear two hard-disk-drive kit removal

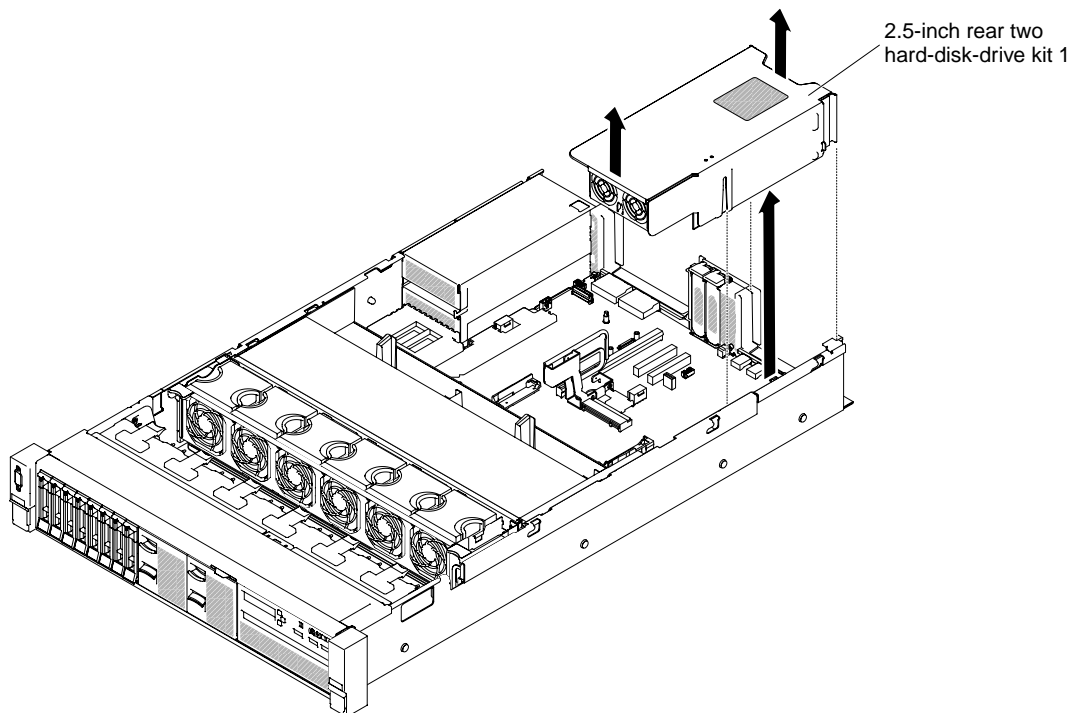

Figure 135. 2.5-inch rear two hard-disk-drive kit removal

- 3.5-inch rear two hard-disk-drive kit removal

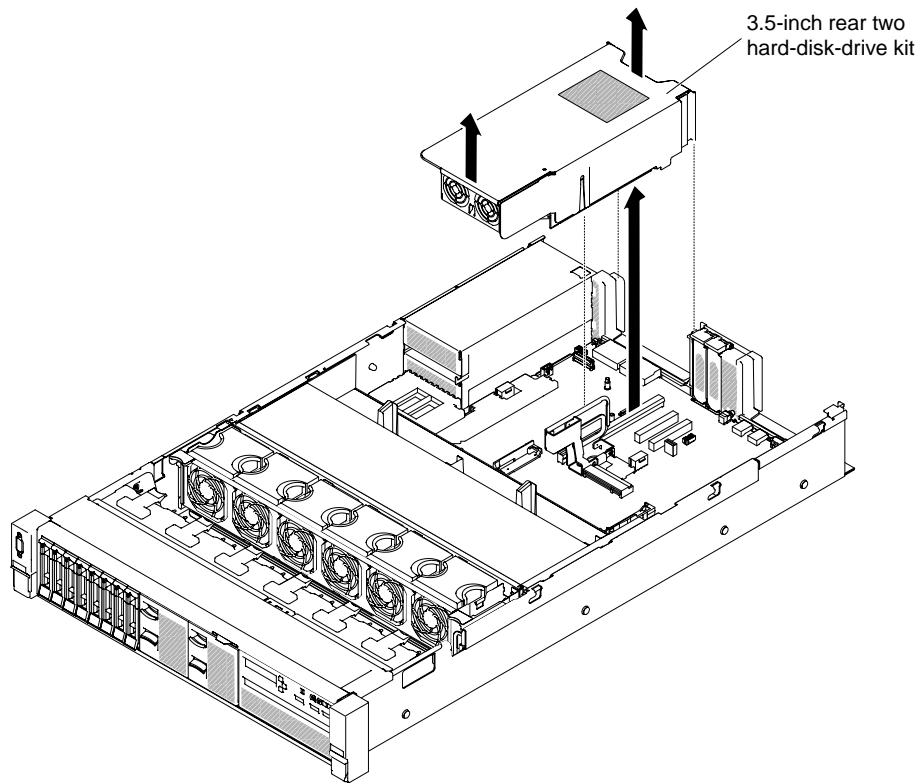

Figure 136. 3.5-inch rear two hard-disk-drive kit removal

## Replacing the rear two hard-disk-drive kit

Use this information to replace the rear two hard-disk-drive kit on the system board.

### Notes:

1. Refer to the following rules before you install the rear two hard-disk-drive kit.
  - 2.5-inch hot-swap hard disk drive model
    - Supports one 2.5-inch rear two hard-disk-drive kit
  - 3.5-inch hot-swap hard disk drive model
    - Supports one 2.5-inch rear two hard-disk-drive kit, or
    - Supports two 2.5-inch rear two hard-disk-drive kits, or
    - Supports one 2.5-inch rear two hard-disk-drive kit and one 3.5-inch rear two hard-disk-drive kit
2. Refer to the following rules for the rear two hard-disk-drive kit numbering.
  - 2.5-inch hot-swap hard disk drive model
    - 2.5-inch rear two hard-disk-drive kit numbering

SATA/SAS hard disk drive bays

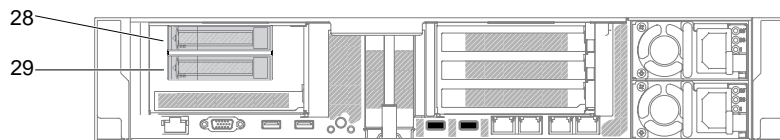

Figure 137. 2.5-inch rear two hard-disk-drive kit numbering

- 2.5-inch rear two hard-disk-drive kit numbering

SATA/SAS hard disk drive bays

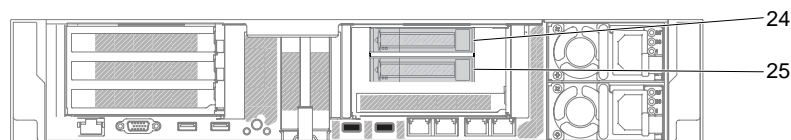

Figure 138. 2.5-inch rear two hard-disk-drive kit numbering

- 3.5-inch hot-swap hard disk drive model
  - 3.5-inch rear two hard-disk-drive kit numbering

SATA/SAS hard disk drive bays

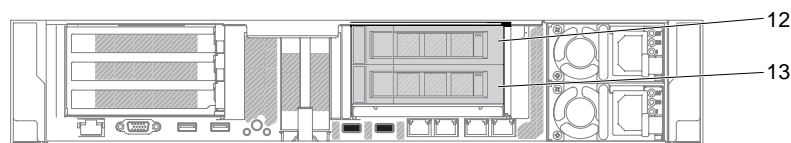

Figure 139. 3.5-inch rear two hard-disk-drive kit numbering

- 3.5-inch rear two hard-disk-drive kit numbering with RAID card

SATA/SAS hard disk drive bays

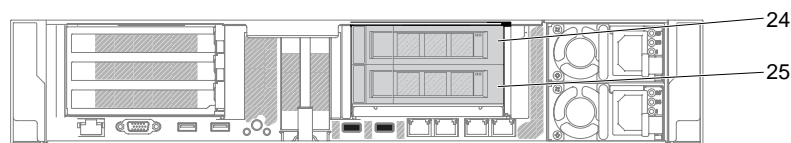

Figure 140. 3.5-inch rear two hard-disk-drive kit numbering with RAID card

To install the rear two hard-disk-drive kit, complete the following steps:

- Step 1. Read the safety information that begins on “Safety” on page v and “Installation guidelines” on page 287.
- Step 2. Turn off the server and peripheral devices and disconnect all power cords.
- Step 3. Remove the top cover (see “Removing the top cover” on page 144).
- Step 4. Align the rear two hard-disk-drive kit with the connector on the system board and align it with the slots on the chassis; then, lower it into the server and press down firmly until the rear two hard-disk-drive kit is seated correctly in the connector on the system board
  - 2.5-inch rear two hard-disk-drive kit installation

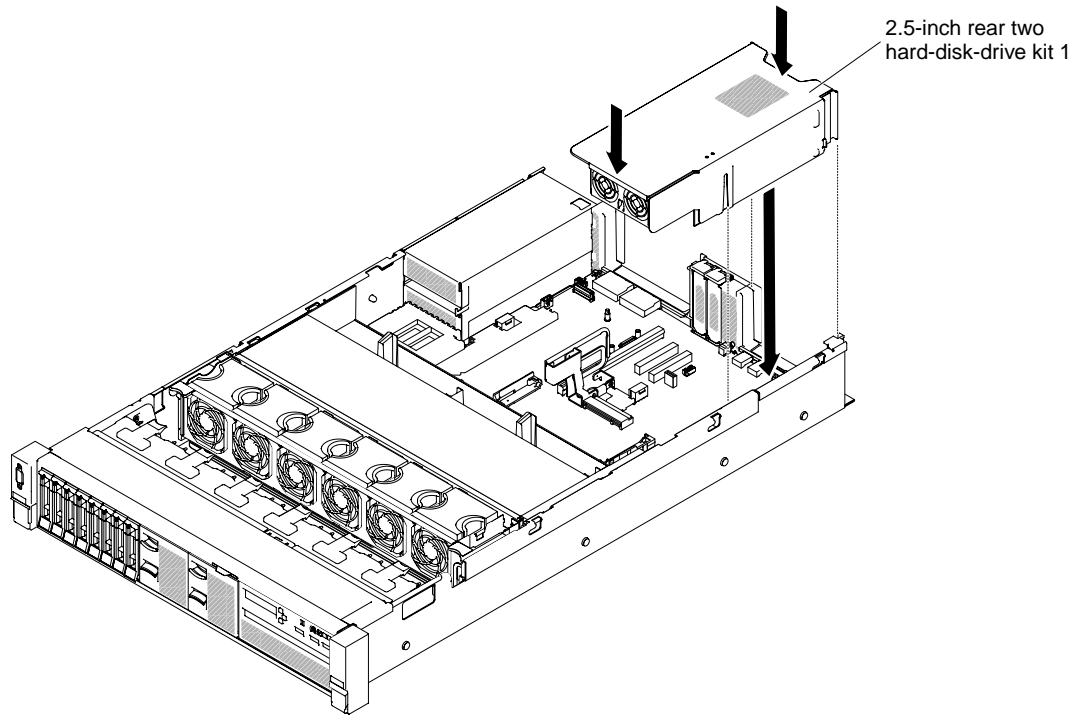

Figure 141. 2.5-inch rear two hard-disk-drive kit installation

- 3.5-inch rear two hard-disk-drive kit installation

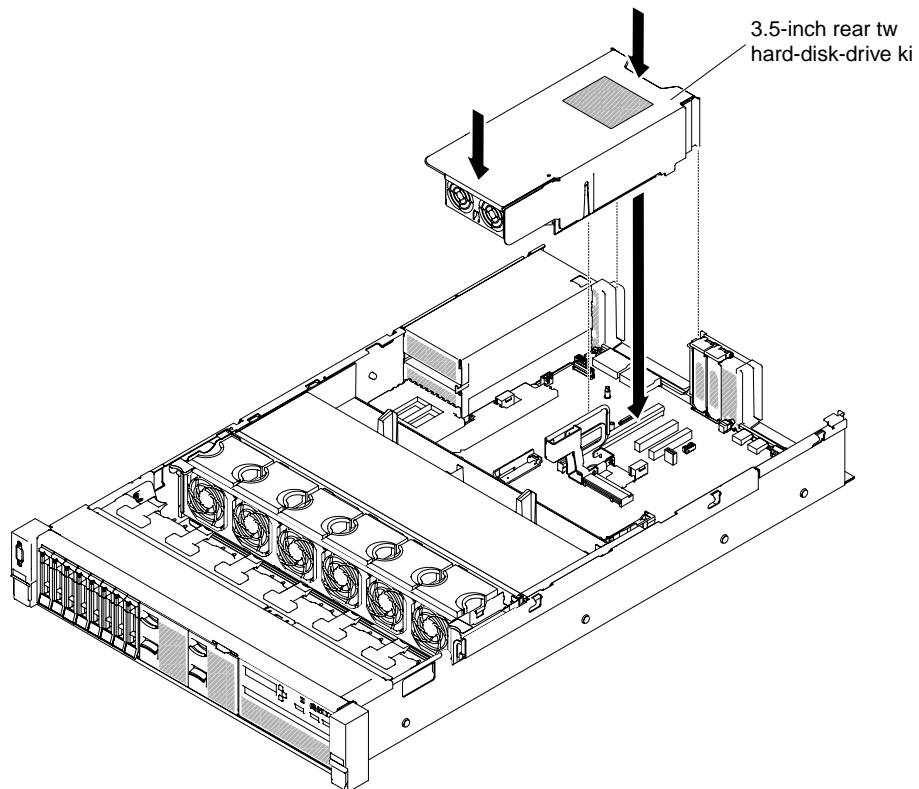
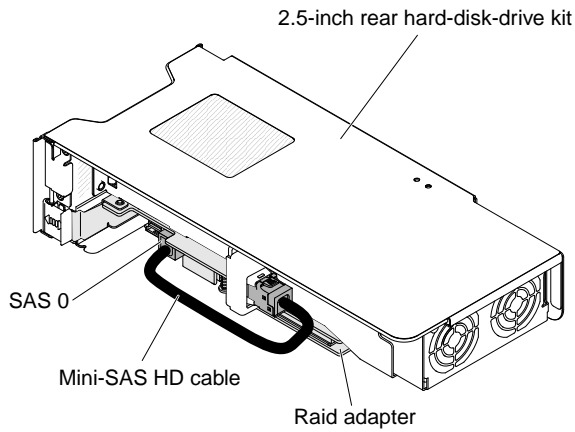

Figure 142. 3.5-inch rear two hard-disk-drive kit installation

Step 5. Connect the Mini-SAS HD cable from the rear hard drive backplane to the RAID card.

- For 2.5-inch rear two hard-disk-drive kit



*Figure 143. 2.5-inch rear two hard-disk-drive kit cable routing*

- For 3.5-inch rear two hard-disk-drive kit, there are two possible cable routing configurations:
  - Connect to the RAID card on the slot 4 from the rear hard drive backplane.



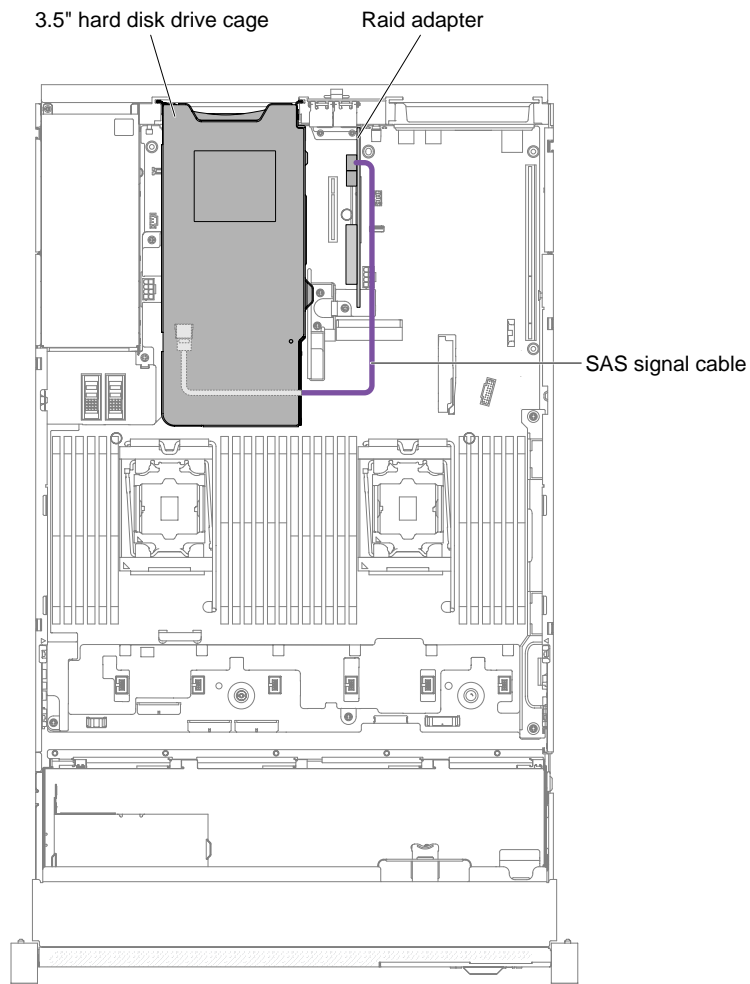

Figure 144. 3.5-inch rear two hard-disk-drive kit cable routing

- Connect to the 3.5-inch HDD hot-swap backplane with 12 HDDs from the rear hard drive backplane

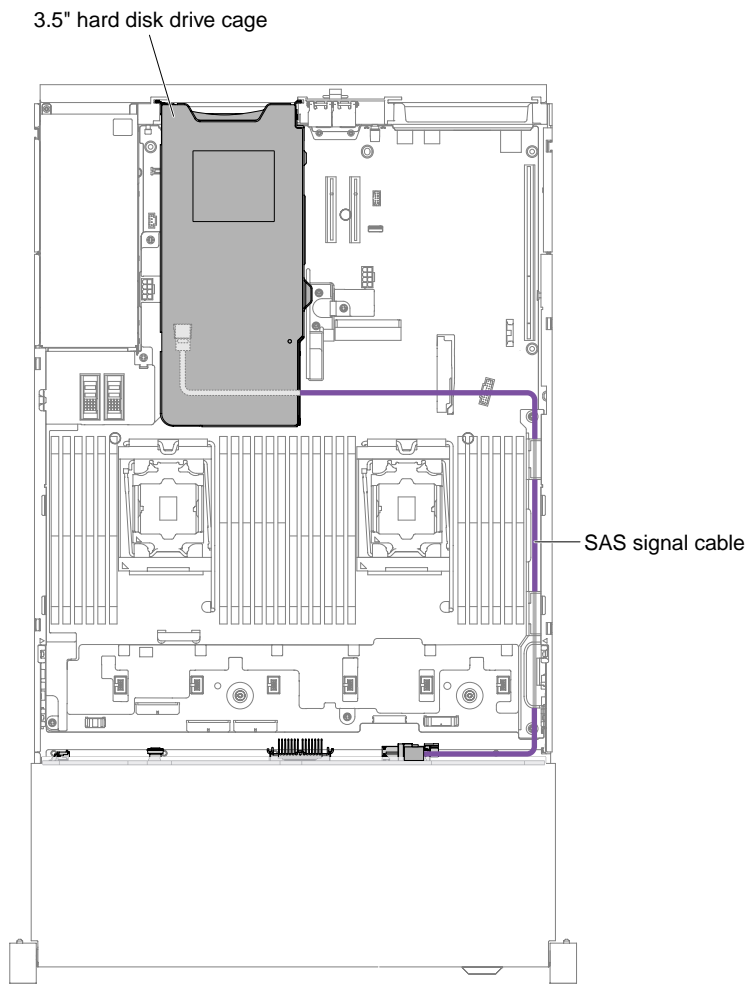

Figure 145. 3.5-inch rear two hard-disk-drive kit cable routing

- Step 6. Press down the HDD kit firmly until the HDD kit is fully seated in the connector on the system board.
- Step 7. Replace the top cover (see “Replacing the top cover” on page 146).
- Step 8. Slide the server into the rack.
- Step 9. Reconnect the power cords and any cables that you removed.
- Step 10. Turn on the peripheral devices and the server.

## Removing an EIA assembly

Use the following instructions to remove an EIA assembly for 2.5-inch and 3.5-inch models.

**Note:** The EIA assembly is available only on some models.

### 2.5-inch model

There are the right EIA assembly and the left EIA assembly on the server, use the following steps to remove them.

#### For the right EIA assembly

1. Read the safety information that begins on “Safety” on page v and “Installation guidelines” on page 287.

2. Turn off the server and peripheral devices, and disconnect the power cord and all external cables.
3. Remove the cover (see “Removing the top cover” on page 144).
4. Remove the fan cage assembly (see “Removing the fan cage assembly” on page 172).
5. Disconnect the front USB/operator information panel cables from the connector mounted on the chassis side.

**Note:** Disengage all latches, release tabs or locks on cable connectors when you disconnect all cables from the system board. Failing to release them before removing the cables will damage the cable sockets on the system board. The cable sockets on the system board are fragile. Any damage to the cable sockets may require replacing the system board.

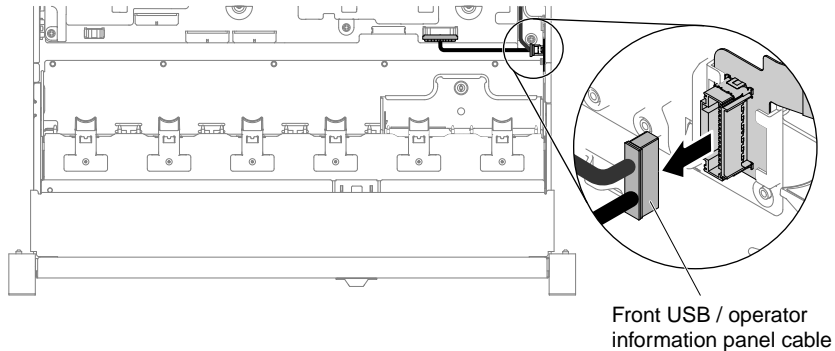

*Figure 146. Front USB/operator information panel cable removal*

6. Loosen screws and remove them.

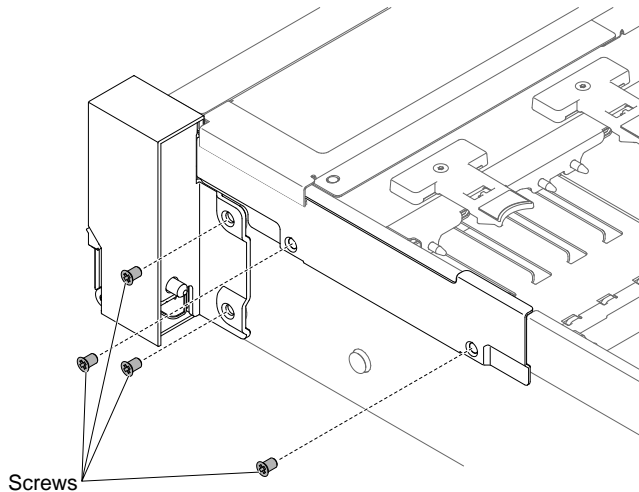

*Figure 147. Screw removal*

7. Tilt the cable cover and remove it from the server.

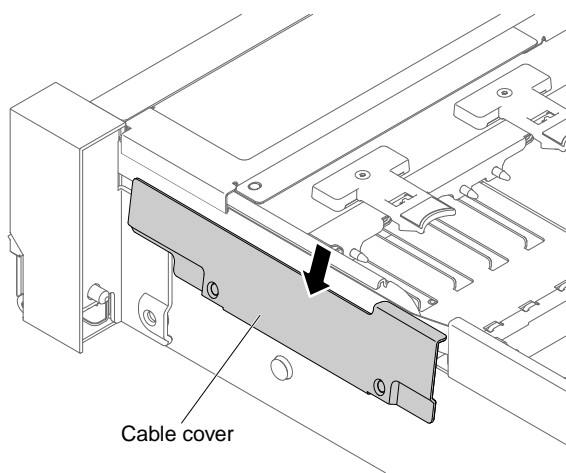

*Figure 148. Cable cover removal*

8. Grasp the EIA assembly and pull it slightly forward to remove it from the server.

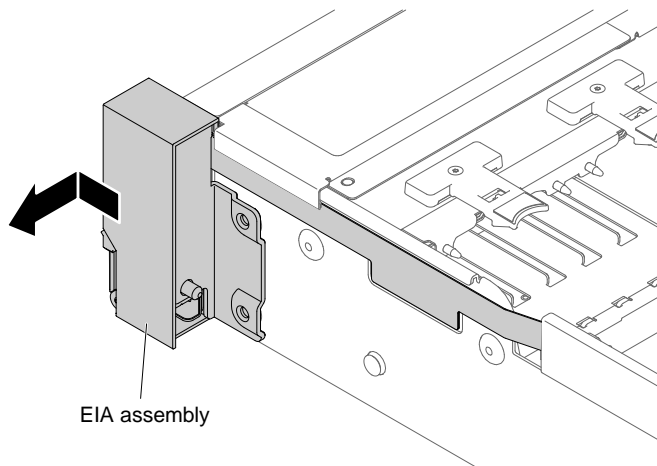

*Figure 149. EIA assembly removal*

9. Position the EIA assembly as shown in the following illustration; then, remove the assembly out of the server.

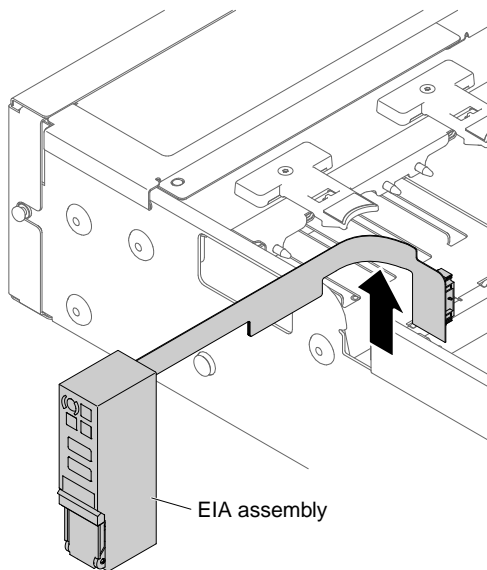

Figure 150. EIA assembly removal

10. If you are instructed to return the EIA assembly, follow all packaging instructions, and use any packaging materials for shipping that are supplied to you.

#### For the left EIA assembly

1. Read the safety information that begins on “Safety” on page v and “Installation guidelines” on page 287.
2. Turn off the server and peripheral devices, and disconnect the power cord and all external cables.
3. Remove the cover (see “Removing the top cover” on page 144).
4. Remove the fan cage assembly (see “Removing the fan cage assembly” on page 172).
5. Disconnect the front video cable from the system board.

**Note:** Disengage all latches, release tabs or locks on cable connectors when you disconnect all cables from the system board. Failing to release them before removing the cables will damage the cable sockets on the system board. The cable sockets on the system board are fragile. Any damage to the cable sockets may require replacing the system board.

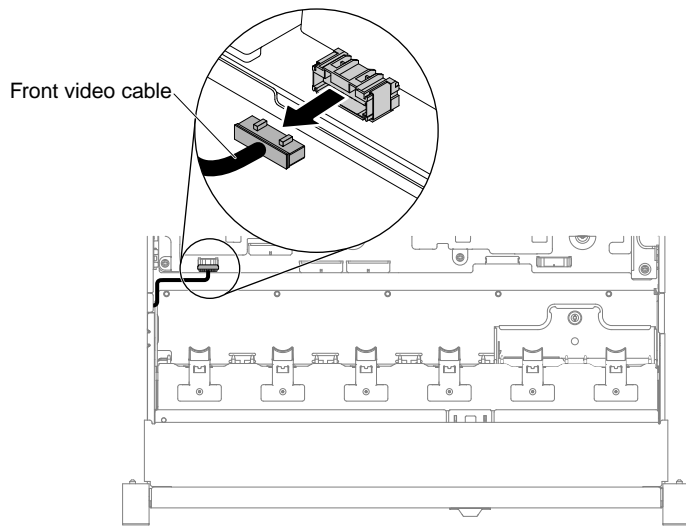

Figure 151. Front video cable removal

6. Loosen screws and remove them.

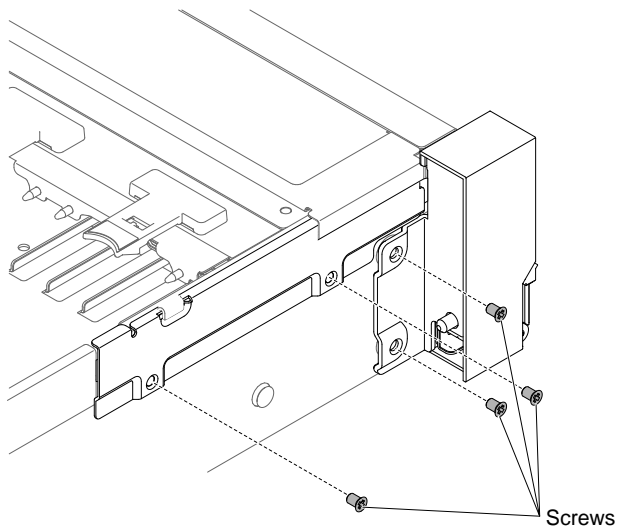

Figure 152. Screw removal

7. Tilt the cable cover and remove it from the server.

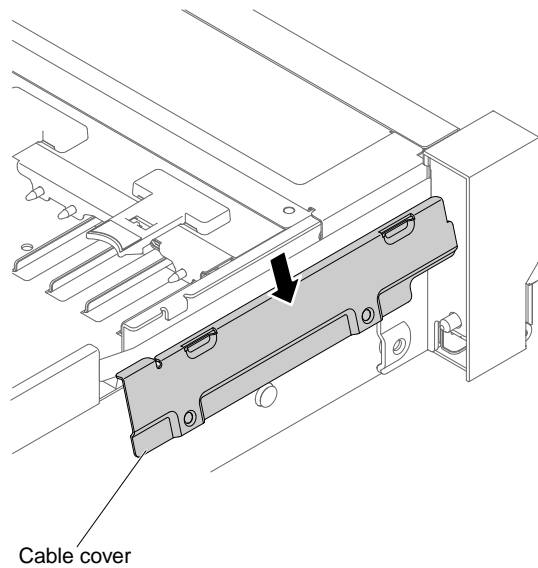

Figure 153. Cable cover removal

8. Grasp the EIA assembly and pull it slightly forward to remove it from the server.

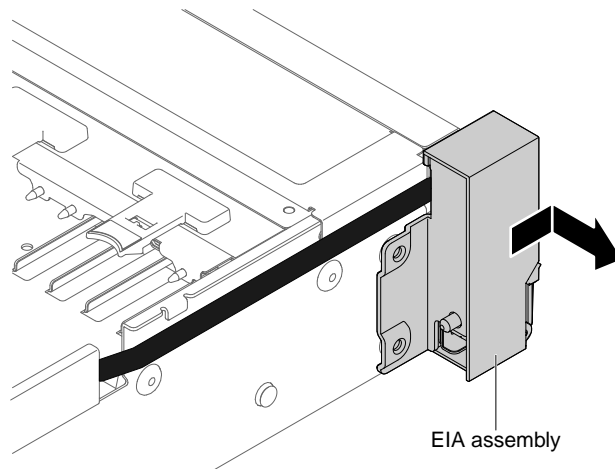

Figure 154. EIA assembly removal

9. If you are instructed to return the EIA assembly, follow all packaging instructions, and use any packaging materials for shipping that are supplied to you.

### 3.5-inch model

There are the right EIA assembly and the left EIA assembly on the server, use the following steps to remove them.

#### For the right EIA assembly

1. Read the safety information that begins on “Safety” on page v and “Installation guidelines” on page 287.
2. Turn off the server and peripheral devices, and disconnect the power cord and all external cables.
3. Remove the top cover (see “Removing the top cover” on page 144).
4. Remove the fan cage assembly (see “Removing the fan cage assembly” on page 172).

5. Disconnect the front USB/operator information panel cables from the connector mounted on the chassis side wall.

**Note:** Disengage all latches, release tabs or locks on cable connectors when you disconnect all cables from the system board. Failing to release them before removing the cables will damage the cable sockets on the system board. The cable sockets on the system board are fragile. Any damage to the cable sockets may require replacing the system board.

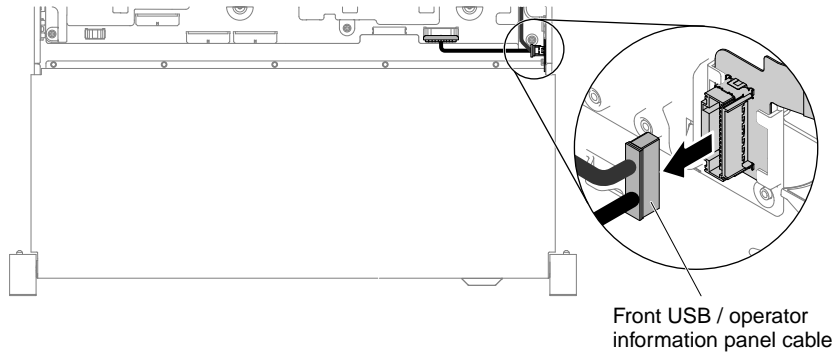

Figure 155. Front USB/operator information panel cable removal

6. Loosen screws and remove them.

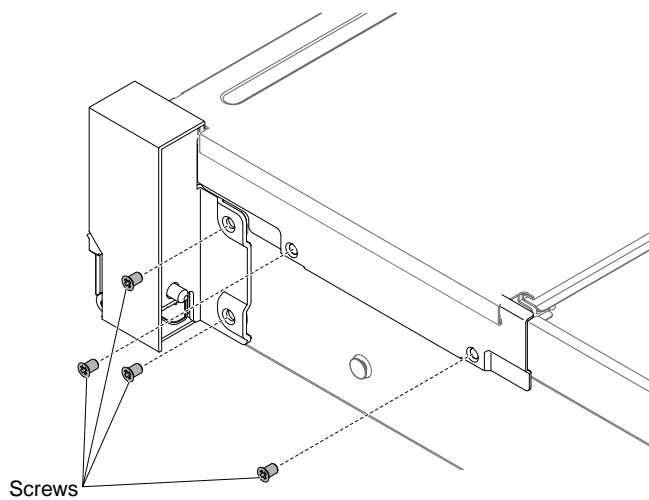

Figure 156. Screw removal

7. To remove the cable cover, angle the cable cover as shown in the following illustration and slide the cable cover slightly towards the rear side of the server to remove it from the server.



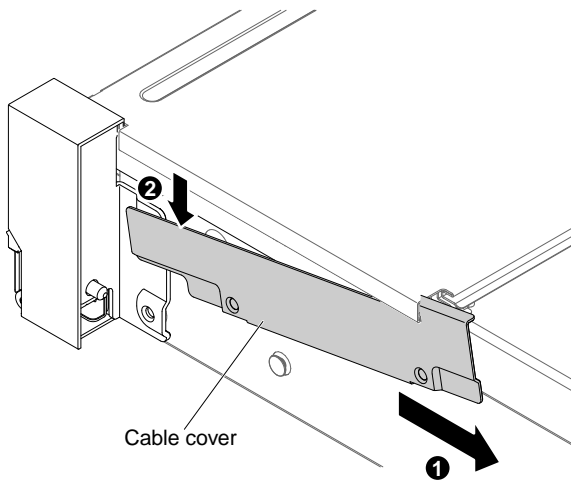

Figure 157. Cable cover removal

8. Grasp the EIA assembly and pull it slightly forward to remove it from the server.

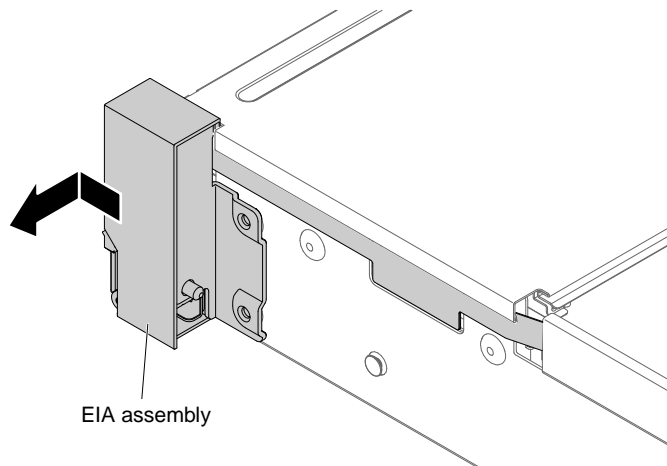

Figure 158. EIA assembly removal

9. Position the EIA assembly as shown in the following illustration; then, remove the assembly out of the server.

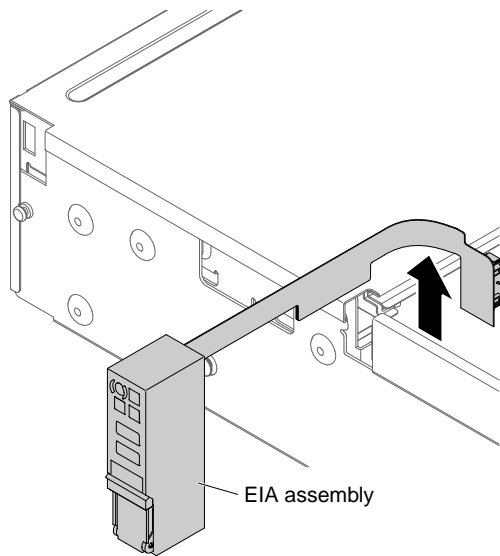

Figure 159. Cable removal

10. If you are instructed to return the EIA assembly, follow all packaging instructions, and use any packaging materials for shipping that are supplied to you.

#### For the left EIA assembly

1. Read the safety information that begins on “Safety” on page v and “Installation guidelines” on page 287.
2. Turn off the server and peripheral devices, and disconnect the power cord and all external cables.
3. Remove the top cover (see “Removing the top cover” on page 144).
4. Remove the fan cage assembly (see “Removing the fan cage assembly” on page 172).
5. Disconnect the front video cable from the system board.

**Note:** Disengage all latches, release tabs or locks on cable connectors when you disconnect all cables from the system board. Failing to release them before removing the cables will damage the cable sockets on the system board. The cable sockets on the system board are fragile. Any damage to the cable sockets may require replacing the system board.

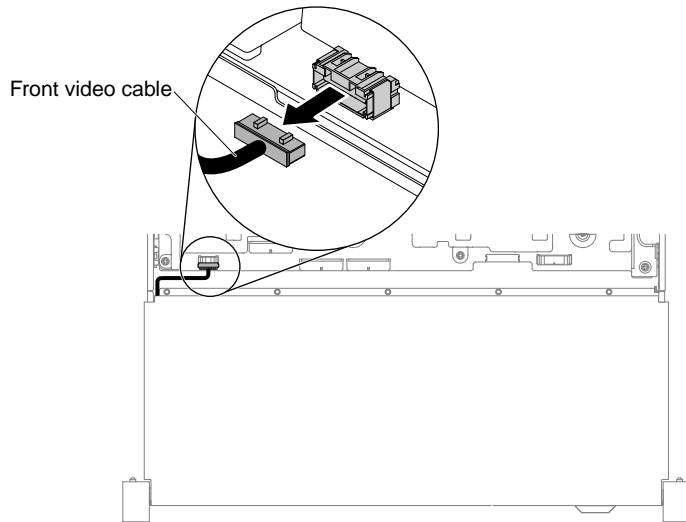

Figure 160. Front video cable removal

6. Loosen screws and remove them.

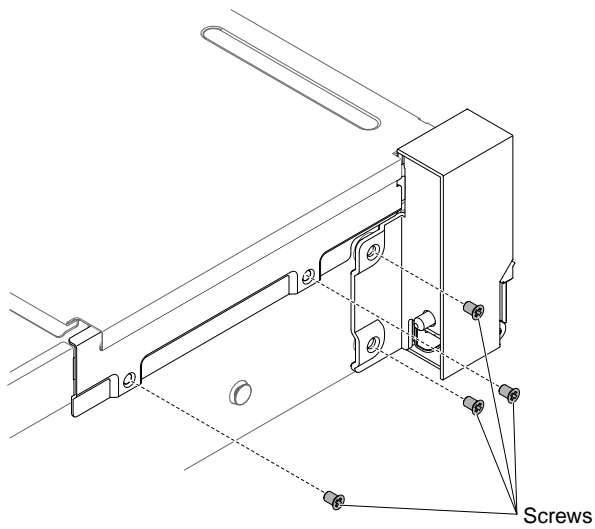

Figure 161. Screw removal

7. Tilt the cable cover and remove it from the server.

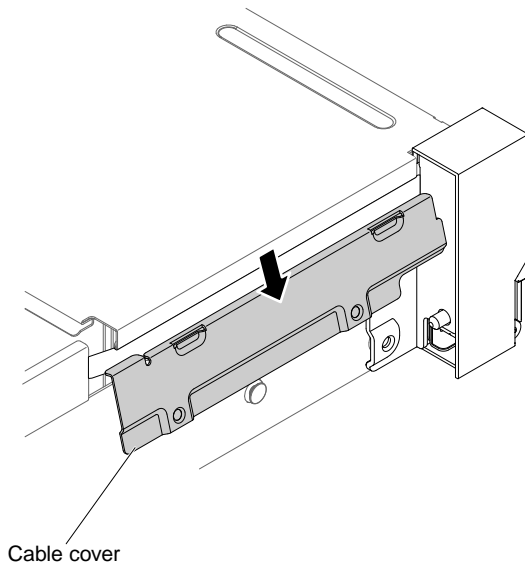

Figure 162. Cable cover removal

8. Grasp the EIA assembly and pull it slightly to remove it from the server.

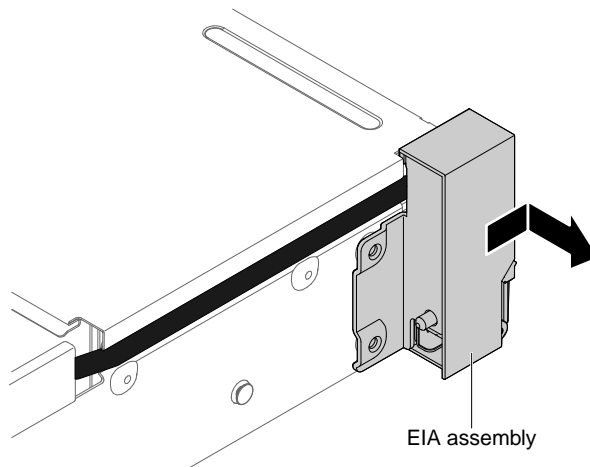

Figure 163. EIA assembly removal

9. If you are instructed to return the EIA assembly, follow all packaging instructions, and use any packaging materials for shipping that are supplied to you.

## Replacing an EIA assembly

Use the following instructions to replace an EIA assembly for 2.5-inch and 3.5-inch models.

**Note:** The EIA assembly is available only on some models.

### 2.5-inch model

There are the right EIA assembly and the left EIA assembly on the server, use the following steps to replace them.

#### For the right EIA assembly

1. Read the safety information that begins on “Safety” on page v and “Installation guidelines” on page 287.
2. Turn off the server and peripheral devices, and disconnect the power cord and all external cables.
3. Remove the top cover (see “Removing the top cover” on page 144).
4. Remove the fan cage (see “Removing the fan cage assembly” on page 172).
5. Insert the cable connector into the cable connector holder.

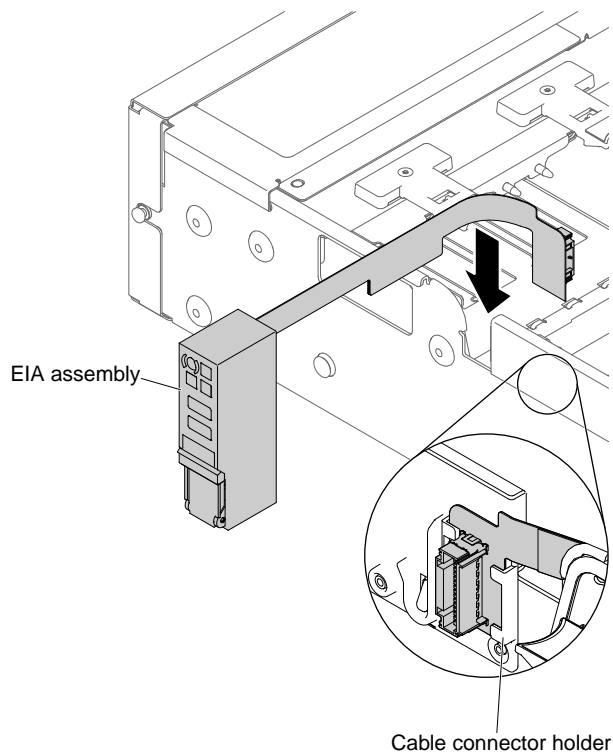

*Figure 164. Cable connector installation*

6. Align the EIA assembly with the alignment pin.

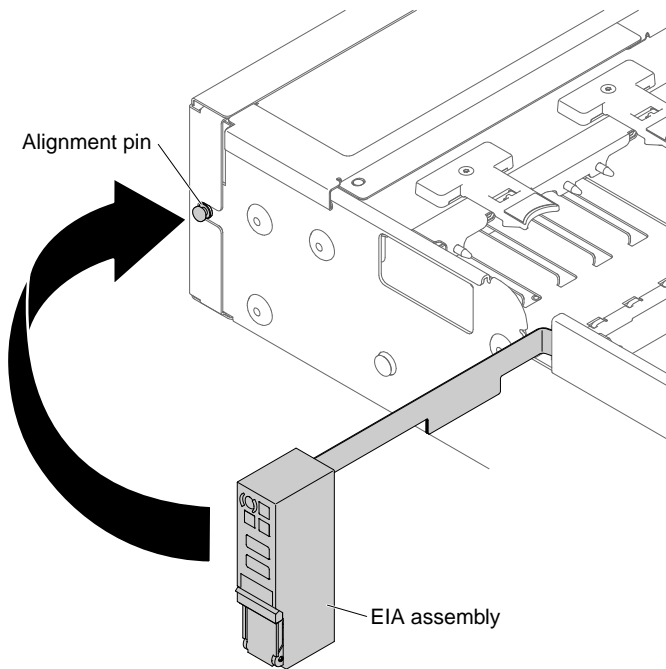

Figure 165. EIA assembly alignment

7. Push the EIA assembly slightly toward the rear of the server to fix the EIA assembly on the server.

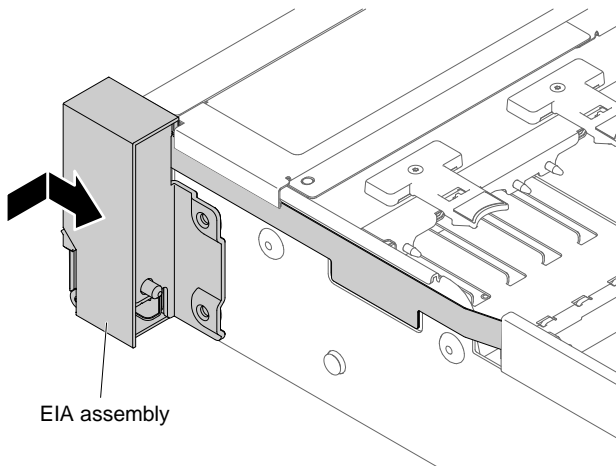

Figure 166. EIA assembly installation

8. Tilt and install the cable cover.

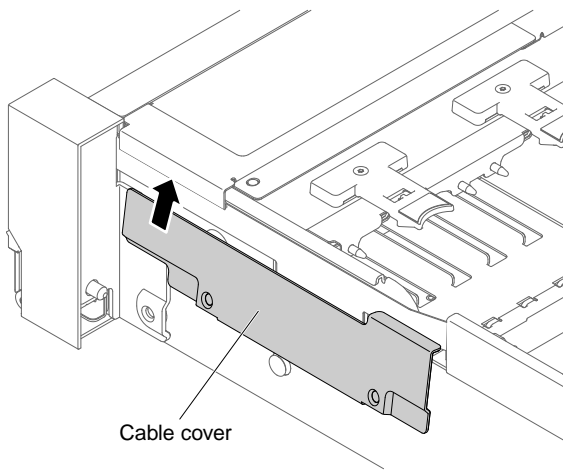

Figure 167. Cable cover installation

9. Fasten screws.

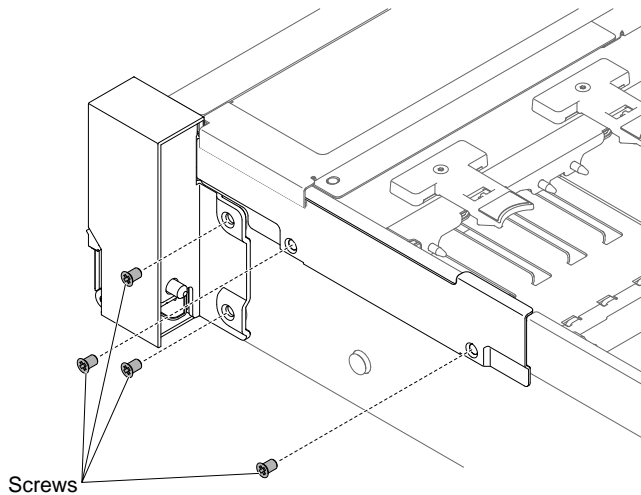

Figure 168. Screw installation

10. Connect the front USB/operator information panel cables to the system board and the connector mounted on the chassis side wall.

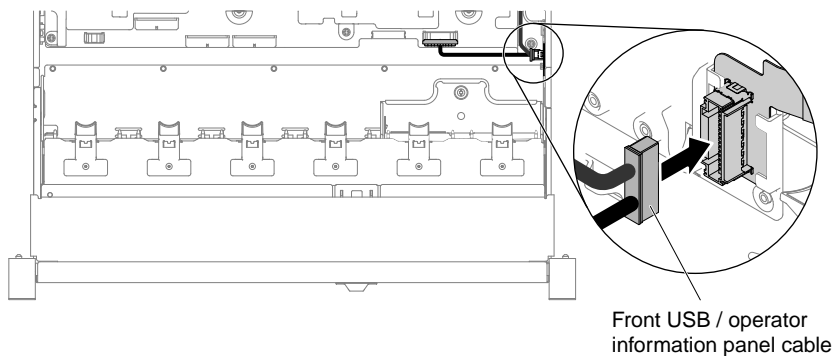

Figure 169. Cable connection

11. Replace the fan cage assembly (see “Replacing the fan cage assembly” on page 173).
12. Replace the top cover (see “Replacing the top cover” on page 146).
13. Slide the server into the rack.
14. Reconnect the power cords and any cables that you removed.
15. Turn on the peripheral devices and the server.

#### For the left EIA assembly

1. Read the safety information that begins on “Safety” on page v and “Installation guidelines” on page 287.
2. Turn off the server and peripheral devices, and disconnect the power cord and all external cables.
3. Remove the top cover (see “Removing the top cover” on page 144).
4. Remove the fan cage assembly (see “Removing the fan cage assembly” on page 172).
5. Route the cable into the slot.

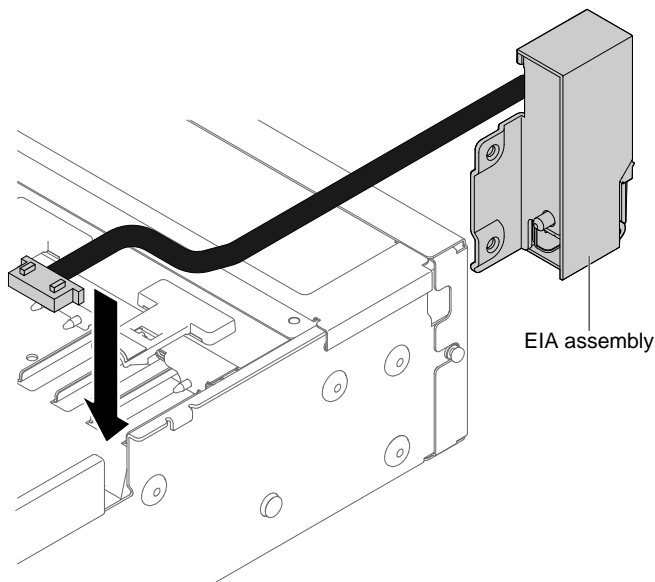

Figure 170. Cable routing

6. Align the EIA assembly with the alignment pin and push it slightly toward the rear of the server fix the EIA assembly on the server.



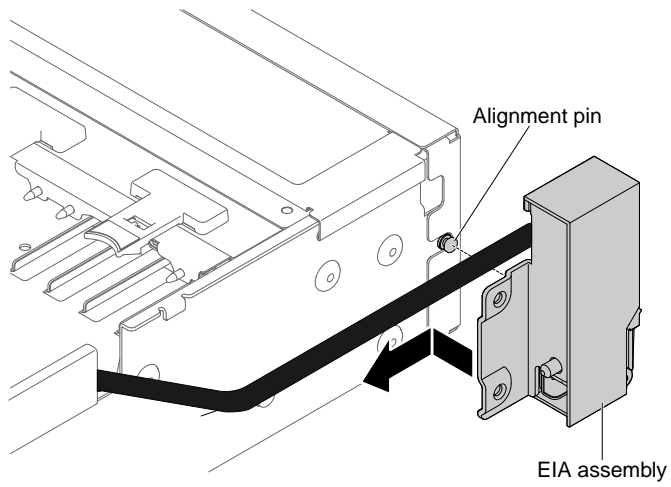

Figure 171. EIA assembly alignment

7. Tilt and install the cable cover.

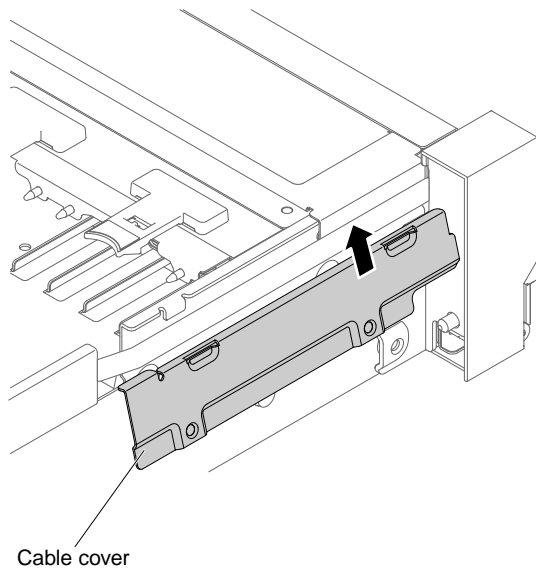

Figure 172. Cable cover installation

8. Fasten screws.

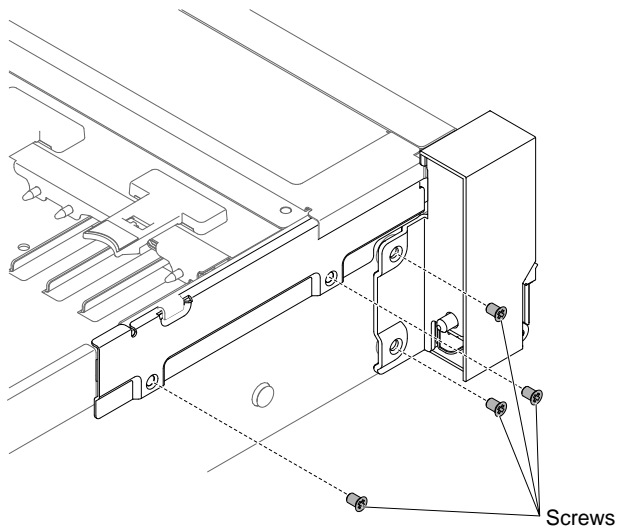

Figure 173. Screw installation

9. Connect the front video cable to the system board.

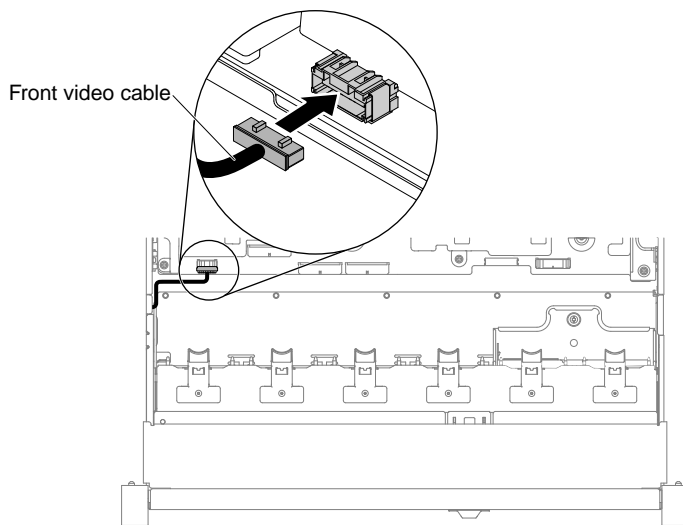

Figure 174. Cable connection

10. Replace the fan cage assembly (see “Replacing the fan cage assembly” on page 173).
11. Replace the top cover (see “Replacing the top cover” on page 146).
12. Slide the server into the rack.
13. Reconnect the power cords and any cables that you removed.
14. Turn on the peripheral devices and the server.

### 3.5-inch model

There are the right EIA assembly and the left EIA assembly on the server, use the following steps to replace them.

#### For the right EIA assembly

1. Read the safety information that begins on “Safety” on page v and “Installation guidelines” on page 287.

2. Turn off the server and peripheral devices, and disconnect the power cord and all external cables.
3. Remove the cover (see “Removing the top cover” on page 144).
4. Remove the fan cage (see “Removing the fan cage assembly” on page 172).
5. Insert the cable connector into the cable connector holder.

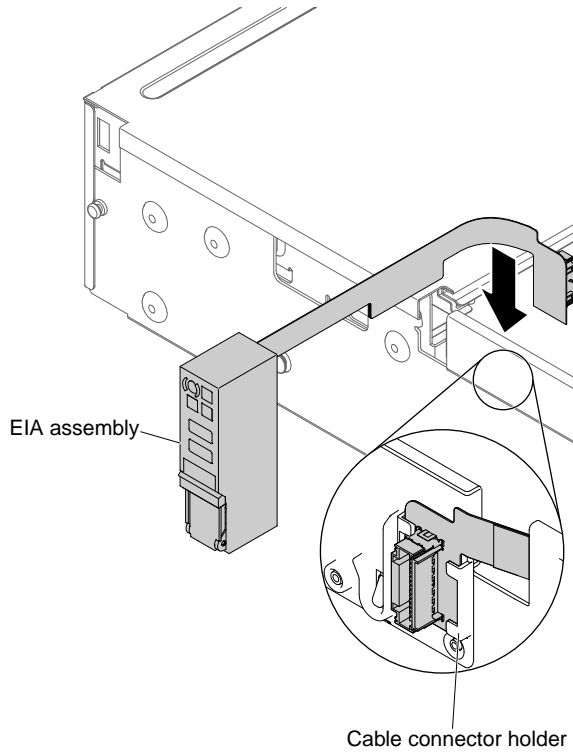

*Figure 175. Cable connector installation*

6. Align the EIA assembly with the alignment pin.

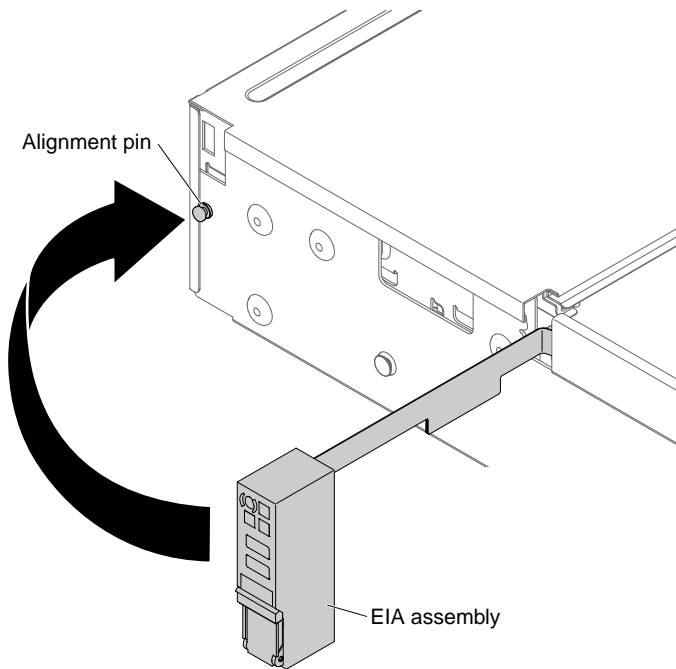

Figure 176. EIA assembly alignment

7. Push the EIA assembly slightly toward the rear of the server to fix the EIA assembly on the server.

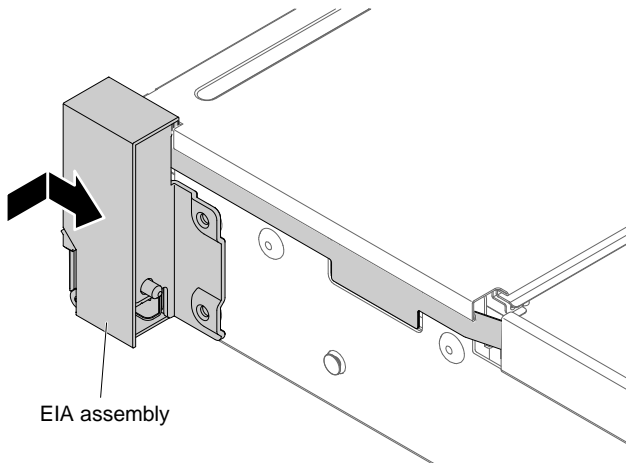

Figure 177. EIA assembly installation

8. Angle the cable cover as shown in the following illustration and slide the cable arm towards the front of the server.

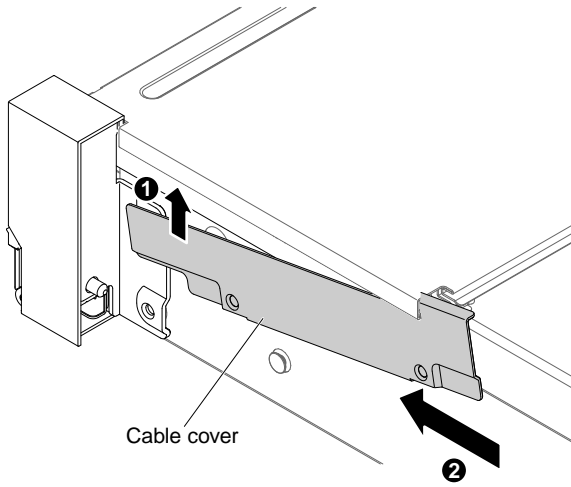

Figure 178. Cable cover installation

9. Fasten screws.

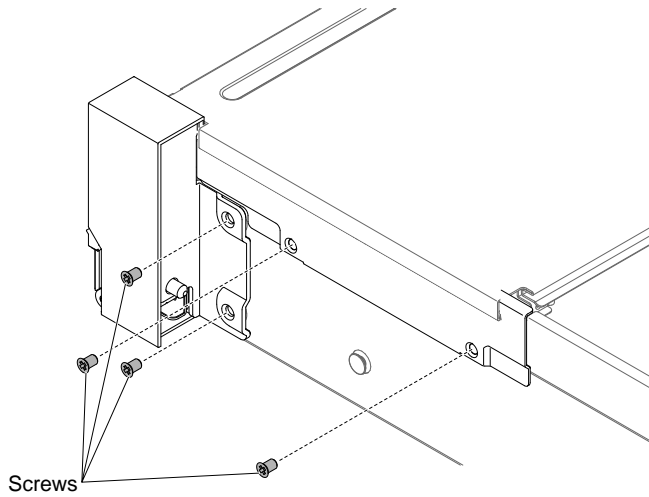

Figure 179. Screw installation

10. Connect the front USB/operator information panel cables to the system board and the connector mounted on the chassis side wall.

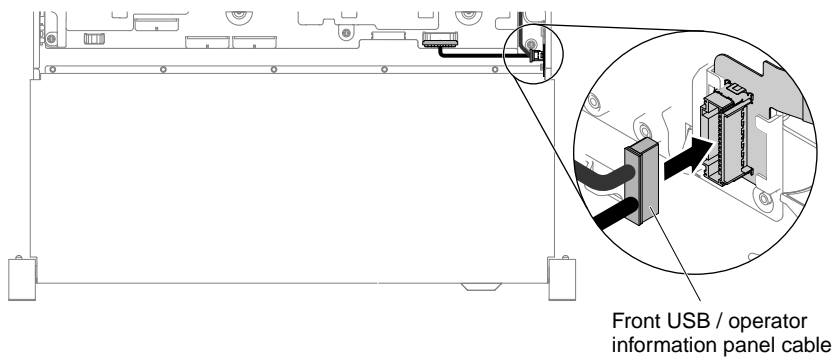

Figure 180. Cable connection

11. Replace the fan cage assembly (see “Replacing the fan cage assembly” on page 173).
12. Replace the top cover (see “Replacing the top cover” on page 146).
13. Slide the server into the rack.
14. Reconnect the power cords and any cables that you removed.
15. Turn on the peripheral devices and the server.

#### For the left EIA assembly

1. Read the safety information that begins on “Safety” on page v and “Installation guidelines” on page 287.
2. Turn off the server and peripheral devices, and disconnect the power cord and all external cables.
3. Remove the top cover (see “Removing the top cover” on page 144).
4. Remove the fan cage assembly (see “Removing the fan cage assembly” on page 172).
5. Route the cable into the slot.

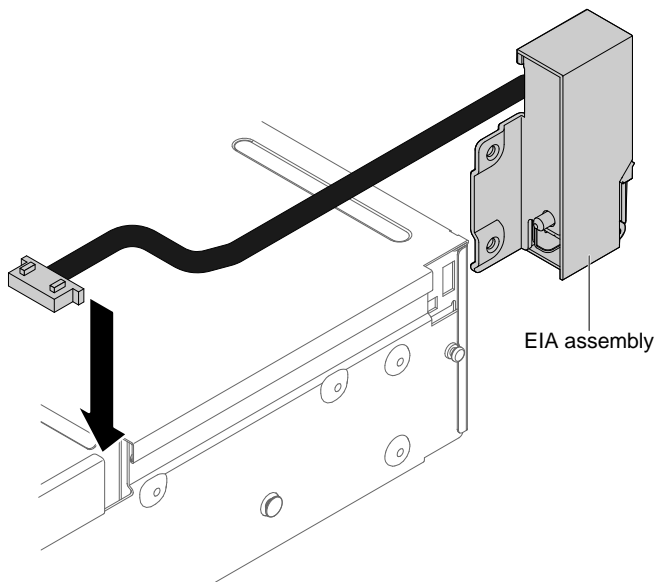

Figure 181. Cable routing

6. Align the EIA assembly with the alignment pin and push it slightly toward the rear of the server to fix the EIA assembly on the server.

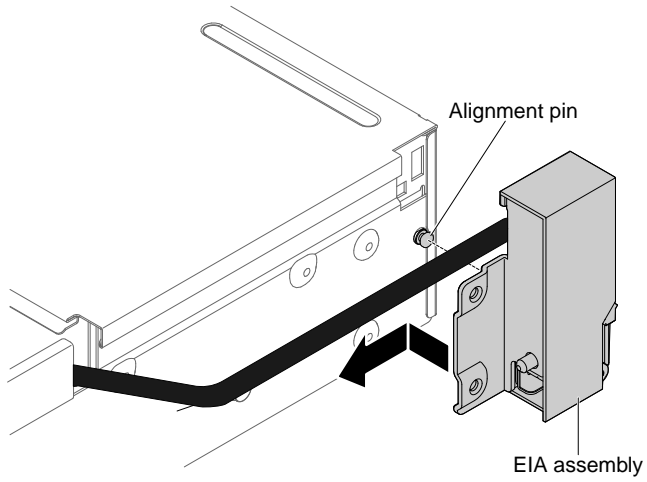

Figure 182. EIA assembly alignment

7. Tilt and install the cable cover.

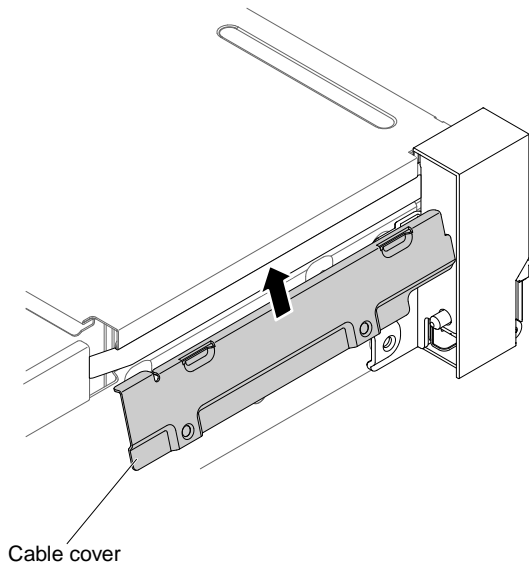

Figure 183. Cable cover installation

8. Fasten screws.

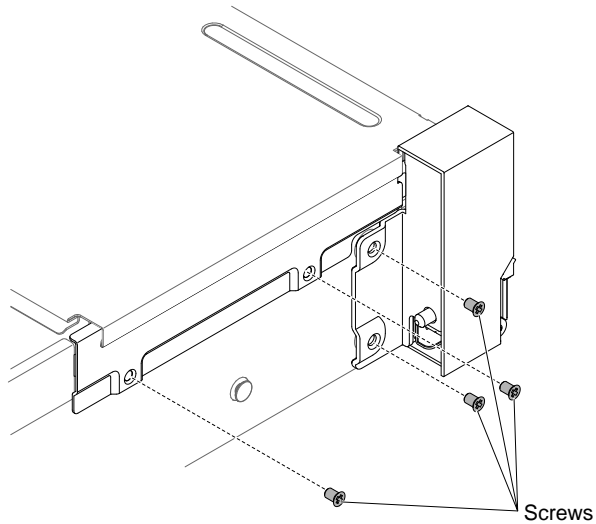

Figure 184. Screw installation

9. Connect the front video cable to the system board.

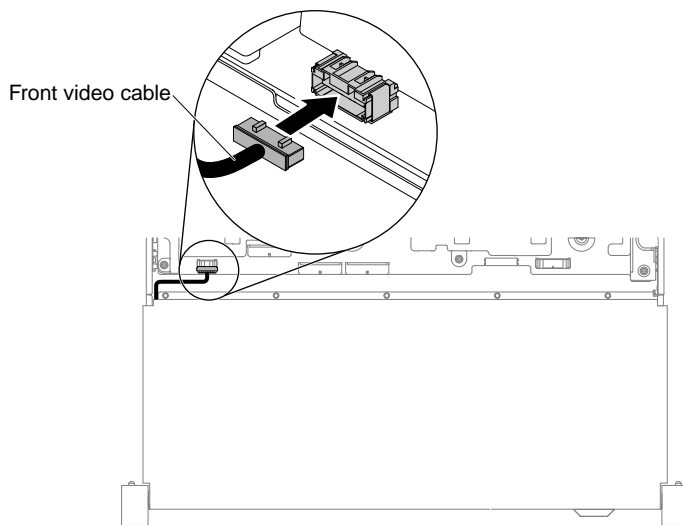

Figure 185. Cable connection

10. Replace the fan cage assembly (see “Replacing the fan cage assembly” on page 173).
11. Replace the top cover (see “Replacing the top cover” on page 146).
12. Slide the server into the rack.
13. Reconnect the power cords and any cables that you removed.
14. Turn on the peripheral devices and the server.

## Removing a hot-swap ac power supply

Use this information to remove a hot-swap ac power supply.

When you remove or install a hot-swap power supply, observe the following precautions.

### Statement 5





**CAUTION:**

The power control button on the device and the power switch on the power supply do not turn off the electrical current supplied to the device. The device also might have more than one power cord. To remove all electrical current from the device, ensure that all power cords are disconnected from the power source.

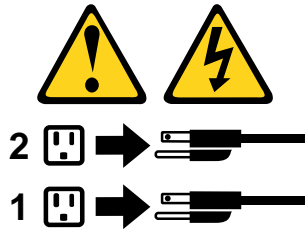

**Statement 8**



**CAUTION:**

Never remove the cover on a power supply or any part that has the following label attached.



**Hazardous voltage, current, and energy levels are present inside any component that has this label attached. There are no serviceable parts inside these components. If you suspect a problem with one of these parts, contact a service technician.**

To remove a hot-swap ac power supply, complete the following steps:

- Step 1. Read the safety information that begins on “Safety” on page v and “Installation guidelines” on page 287.
- Step 2. If only one power supply is installed, turn off the server and peripheral devices and disconnect all power cords.
- Step 3. If the server is in a rack, at the back of the server, pull back the cable management arm to gain access to the rear of the server and the power supply.
- Step 4. Press and hold the release tab to the left. Grasp the handle and pull the power supply out of the server.

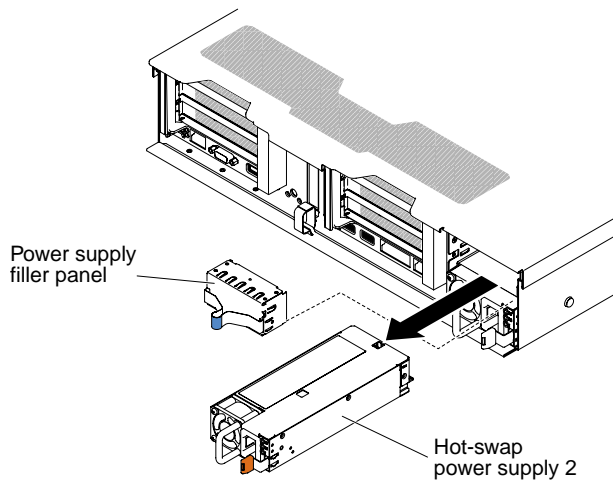

Figure 186. Power supply removal

Step 5. If you are instructed to return the power supply, follow all packaging instructions, and use any packaging materials for shipping that are supplied to you.

## Replacing a hot-swap ac power supply

Use this information to replace a hot-swap ac power supply.

The following notes describe the type of power supply that the server supports and other information that you must consider when you install a power supply:

- Before you install an additional power supply or replace a power supply with one of a different wattage, you may use the Power Configurator utility to determine current system power consumption. For more information and to download the utility, go to <http://www.ibm.com/systems/bladecenter/resources/powerconfig.html>.
- The server comes with one hot-swap 12-volt output power supply that connects to power supply bay 1. The input voltage is 100-127 V ac or 200-240 V ac auto-sensing for AC power supplied and is -48V dc or -60V dc auto-sensing for DC power supplies.
- Power supplies in the server must be with the same power rating or wattage, and the same 80-plus efficiency level to ensure that the server will operate correctly. For example, you cannot mix 550-watt and 750-watt power supplies in the server. Moreover, you cannot mix 750-watt Platinum and 750-watt Titanium supplies in the server.
- Power supply 1 is the default/primary power supply. If power supply 1 fails, you must replace the power supply with the same wattage and the same 80-plus efficiency level immediately.
- You can order an optional power supply for redundancy.
- These power supplies are designed for parallel operation. In the event of a power-supply failure, the redundant power supply continues to power the system. The server supports a maximum of two power supplies.

### Statement 5



### CAUTION:

The power control button on the device and the power switch on the power supply do not turn off the electrical current supplied to the device. The device also might have more than one power cord. To remove all electrical current from the device, ensure that all power cords are disconnected from the power source.

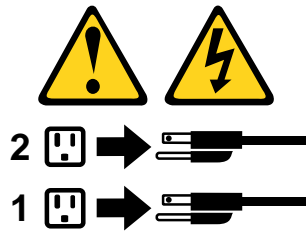

#### Statement 8



#### CAUTION:

Never remove the cover on a power supply or any part that has the following label attached.



Hazardous voltage, current, and energy levels are present inside any component that has this label attached. There are no serviceable parts inside these components. If you suspect a problem with one of these parts, contact a service technician.

To install a power supply, complete the following steps:

- Step 1. Read the safety information that begins on “Safety” on page v and “Installation guidelines” on page 287.
- Step 2. Touch the static-protective package that contains the hot-swap power supply to any unpainted metal surface on the server; then, remove the power supply from the package and place it on a static-protective surface.
- Step 3. If you are installing a hot-swap power supply into an empty bay, remove the power-supply filler from the power-supply bay.

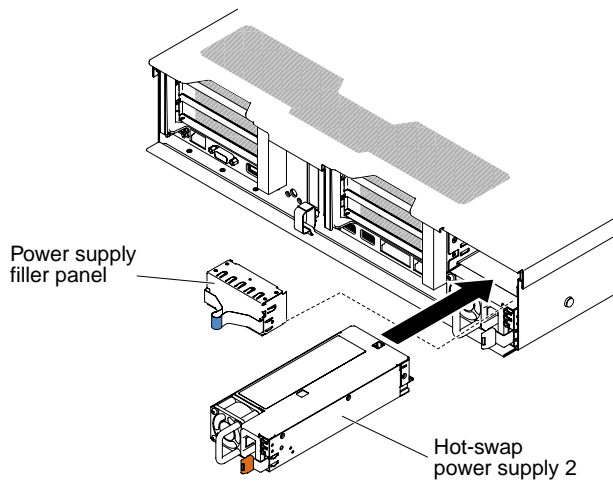

Figure 187. Power supply installation

- Step 4. Grasp the handle on the rear of the power supply and slide the power supply forward into the power-supply bay until it clicks. Make sure that the power supply connects firmly into the power-supply connector.

**Attention:** Do not mix two power supplies with different rating, wattage and efficiency in the server, it is not supported.

- Step 5. Connect the power cord for the new power supply to the power-cord connector on the power supply. The following illustration shows the power-cord connectors on the back of the server.



- Step 6. Route the power cord through the cable hook-and-loop on the rear of the server, to prevent the power cord from being accidentally pulled out when you slide the server in and out of the rack.
- Step 7. Connect the other end of the power cord to a properly grounded electrical outlet.
- Step 8. Make sure that the ac power LED and the dc power LED on the ac power supply are lit, indicating that the power supply is operating correctly. The two green LEDs are to the right of the power-cord connector.
- Step 9. If you are replacing a power supply to the server, attach the redundant power information label that comes with this option on the server cover near the power supplies.

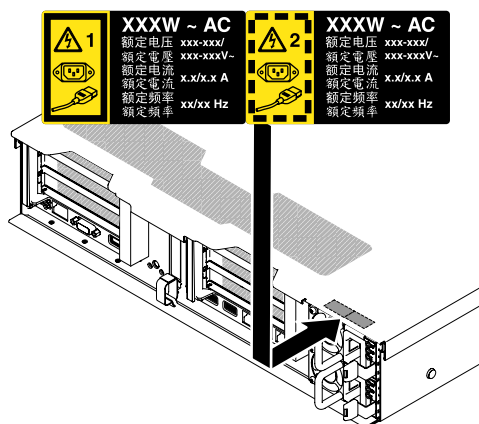

Figure 188. Attaching the redundant power information label

## Removing a hot-swap dc power supply

Use this information to remove a hot-swap dc power supply.

When you remove or install a hot-swap dc power supply, observe the following precautions.

### Statement 29



**CAUTION:** This equipment is designed to permit the connection of the earthed conductor of the dc supply circuit to the earthing conductor at the equipment.

This equipment is designed to permit the connection of the earthed conductor of the dc supply circuit to the earthing conductor at the equipment. If this connection is made, all of the following conditions must be met:

- This equipment shall be connected directly to the dc supply system earthing electrode conductor or to a bonding jumper from an earthing terminal bar or bus to which the dc supply system earthing electrode conductor is connected.
- This equipment shall be located in the same immediate area (such as, adjacent cabinets) as any other equipment that has a connection between the earthed conductor of the same dc supply circuit and the earthing conductor, and also the point of earthing of the dc system. The dc system shall not be earthed elsewhere.
- The dc supply source shall be located within the same premises as this equipment.
- Switching or disconnecting devices shall not be in the earthed circuit conductor between the dc source and the point of connection of the earthing electrode conductor.

### Statement 31



 **DANGER**

**Electrical current from power, telephone, and communication cables is hazardous.  
To avoid a shock hazard:**

- **Do not connect or disconnect any cables or perform installation, maintenance, or reconfiguration of this product during an electrical storm.**
- **Connect all power cords to a properly wired and grounded power source.**
- **Connect to properly wired power sources any equipment that will be attached to this product.**
- **When possible, use one hand only to connect or disconnect signal cables.**
- **Never turn on any equipment when there is evidence of fire, water, or structural damage.**
- **Disconnect the attached ac power cords, dc power sources, network connections, telecommunications systems, and serial cables before you open the device covers, unless you are instructed otherwise in the installation and configuration procedures.**
- **Connect and disconnect cables as described in the following table when you install, move, or open covers on this product or attached devices.**

**To Connect:**

1. Turn OFF all power sources and equipment that is to be attached to this product.
2. Attach signal cables to the product.
3. Attach power cords to the product.
  - For ac systems, use appliance inlets.
  - For dc systems, ensure correct polarity of -48 V dc connections: RTN is + and -48 V dc is -. Earth ground should use a two-hole lug for safety.
4. Attach signal cables to other devices.
5. Connect power cords to their sources.
6. Turn ON all the power sources.

**To Disconnect:**

1. Turn OFF all power sources and equipment that is to be attached to this product.
  - For ac systems, remove all power cords from the chassis power receptacles or interrupt power at the ac power distribution unit.
  - For dc systems, disconnect dc power sources at the breaker panel or by turning off the power source. Then, remove the dc cables.
2. Remove the signal cables from the connectors.
3. Remove all cables from the devices.

**Statement 33**



**CAUTION:**

**This product does not provide a power-control button. Turning off blades or removing power modules and I/O modules does not turn off electrical current to the product. The product also might have more than one power cord. To remove all electrical current from the product, make sure that all power cords are disconnected from the power source.**

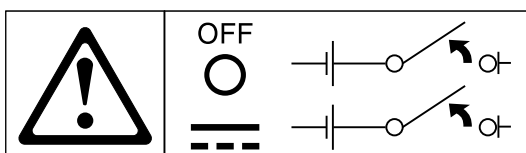

## Statement 34



### CAUTION:

To reduce the risk of electric shock or energy hazards:

- This equipment must be installed by trained service personnel in a restricted-access location, as defined by the NEC and IEC 60950-1, First Edition, The Standard for Safety of Information Technology Equipment.
- Connect the equipment to a properly grounded safety extra low voltage (SELV) source. A SELV source is a secondary circuit that is designed so that normal and single fault conditions do not cause the voltages to exceed a safe level (60 V direct current).
- Incorporate a readily available approved and rated disconnect device in the field wiring.
- See the specifications in the product documentation for the required circuit-breaker rating for branch circuit overcurrent protection.
- Use copper wire conductors only. See the specifications in the product documentation for the required wire size.
- See the specifications in the product documentation for the required torque values for the wiring-terminal screws.

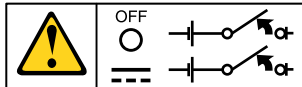

**Important:** Be sure to read the multilingual safety instructions on the CD that comes with the server before you use the product.

To remove a hot-swap dc power supply, complete the following steps:

- Step 1. Read the safety information that begins on “Safety” on page v and “Installation guidelines” on page 287.
- Step 2. If only one power supply is installed, turn off the server and peripheral devices and disconnect all power cords.
- Step 3. If the server is in a rack, at the back of the server, pull back the cable management arm to gain access to the rear of the server and the power supply.
- Step 4. Press and hold the release tab to the left. Grasp the handle and pull the power supply out of the server.

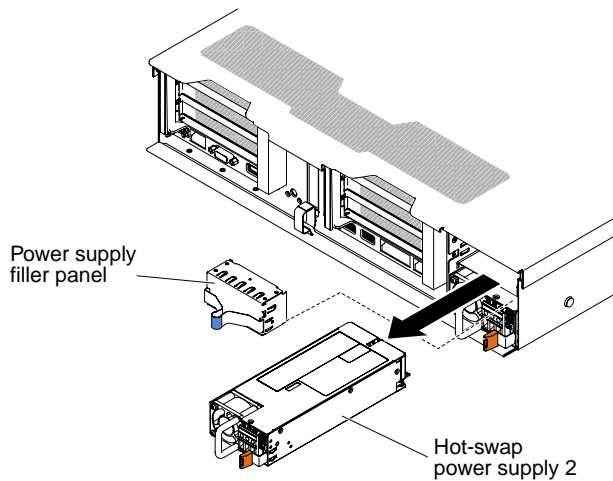

Figure 189. Power supply removal

Step 5. If you are instructed to return the power supply, follow all packaging instructions, and use any packaging materials for shipping that are supplied to you.

## Replacing a hot-swap dc power supply

Use this information to replace a hot-swap dc power supply.

The following notes describe the type of power supply that the server supports and other information that you must consider when you install a power supply:

- Before you install an additional power supply or replace a power supply with one of a different wattage, you may use the IBM Power Configurator utility to determine current system power consumption. For more information and to download the utility, go to <http://www.ibm.com/systems/bladecenter/resources/powerconfig.html>.
- The server comes with one hot-swap 12-volt output power supply that connects to power supply bay 1. The input voltage is -48 V dc or -60 V dc auto-sensing.
- Before you install a dc power supply in the server, you must remove all ac power supplies. Do not use both ac and dc power supplies in the same server. Install up to two dc power supplies or up to two ac power supplies, but not a combination.
- Power supply 1 is the default/primary power supply. If power supply 1 fails, you must replace the power supply with the same wattage immediately.
- You can order an optional power supply for redundancy.
- These power supplies are designed for parallel operation. In the event of a power-supply failure, the redundant power supply continues to power the system. The server supports a maximum of two power supplies.
- It is the customer's responsibility to supply the necessary power cable.

### To reduce the risk of electric shock or energy hazards:

- Use a proper circuit breaker.
- Use 4 mm<sup>2</sup> (10 AWG) at 90° C copper wire.
- Torque the wiring-terminal screws to 0.50 ~ 0.60 newton-meters (4.43 ~ 5.31 inch-pounds).

For more information, see Statement 34 on page below.



- If the power source requires ring terminals, you must use a crimping tool to install the ring terminals to the power cord wires. The ring terminals must be UL approved and must accommodate the wire that is described in the above-mentioned note .

**Statement 29:**



**CAUTION:**

**This equipment is designed to permit the connection of the earthed conductor of the dc supply circuit to the earthing conductor at the equipment.**

This equipment is designed to permit the connection of the earthed conductor of the dc supply circuit to the earthing conductor at the equipment. If this connection is made, all of the following conditions must be met:

- This equipment shall be connected directly to the dc supply system earthing electrode conductor or to a bonding jumper from an earthing terminal bar or bus to which the dc supply system earthing electrode conductor is connected.
- This equipment shall be located in the same immediate area (such as, adjacent cabinets) as any other equipment that has a connection between the earthed conductor of the same dc supply circuit and the earthing conductor, and also the point of earthing of the dc system. The dc system shall not be earthed elsewhere.
- The dc supply source shall be located within the same premises as this equipment.
- Switching or disconnecting devices shall not be in the earthed circuit conductor between the dc source and the point of connection of the earthing electrode conductor.

**Statement 31**



**Electrical current from power, telephone, and communication cables is hazardous.**

**To avoid a shock hazard:**

- **Do not connect or disconnect any cables or perform installation, maintenance, or reconfiguration of this product during an electrical storm.**
- **Connect all power cords to a properly wired and grounded power source.**
- **Connect to properly wired power sources any equipment that will be attached to this product.**
- **When possible, use one hand only to connect or disconnect signal cables.**
- **Never turn on any equipment when there is evidence of fire, water, or structural damage.**
- **Disconnect the attached ac power cords, dc power sources, network connections, telecommunications systems, and serial cables before you open the device covers, unless you are instructed otherwise in the installation and configuration procedures.**
- **Connect and disconnect cables as described in the following table when you install, move, or open covers on this product or attached devices.**

**To Connect:**

1. Turn OFF all power sources and equipment that is to be attached to this product.
2. Attach signal cables to the product.
3. Attach power cords to the product.
  - For ac systems, use appliance inlets.
  - For dc systems, ensure correct polarity of -48 V dc connections: RTN is + and -48 V dc is -. Earth ground should use a two-hole lug for safety.
4. Attach signal cables to other devices.
5. Connect power cords to their sources.
6. Turn ON all the power sources.

**To Disconnect:**

1. Turn OFF all power sources and equipment that is to be attached to this product.
  - For ac systems, remove all power cords from the chassis power receptacles or interrupt power at the ac power distribution unit.
  - For dc systems, disconnect dc power sources at the breaker panel or by turning off the power source. Then, remove the dc cables.
2. Remove the signal cables from the connectors.
3. Remove all cables from the devices.

**Statement 33****CAUTION:**

This product does not provide a power-control button. Turning off blades or removing power modules and I/O modules does not turn off electrical current to the product. The product also might have more than one power cord. To remove all electrical current from the product, make sure that all power cords are disconnected from the power source.

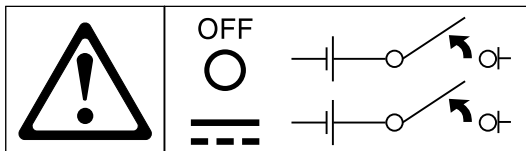
**Statement 34****CAUTION:**

To reduce the risk of electric shock or energy hazards:

- This equipment must be installed by trained service personnel in a restricted-access location, as defined by the NEC and IEC 60950-1, First Edition, The Standard for Safety of Information Technology Equipment.
- Connect the equipment to a properly grounded safety extra low voltage (SELV) source. A SELV source is a secondary circuit that is designed so that normal and single fault conditions do not cause the voltages to exceed a safe level (60 V direct current).
- Incorporate a readily available approved and rated disconnect device in the field wiring.
- See the specifications in the product documentation for the required circuit-breaker rating for branch circuit overcurrent protection.

- Use copper wire conductors only. See the specifications in the product documentation for the required wire size.
- See the specifications in the product documentation for the required torque values for the wiring-terminal screws.

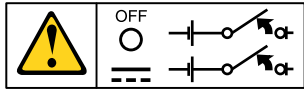

**Important:** Be sure to read the multilingual safety instructions on the CD that comes with the server before you use the product.

To install a hot-swap dc power supply, complete the following steps:

**Attention:** Only trained service personnel other than IBM service technicians are authorized to install and remove the -48 volt dc power supply, and make the connections to and disconnections from the -48 volt dc power source. IBM service technicians are not certified or authorized to install or remove the -48 volt power cable. The customer is responsible for ensuring that only trained service personnel install or remove the -48 volt power cable.

- Step 1. Read the safety information that begins on “Safety” on page v and “Installation guidelines” on page 287.
- Step 2. Touch the static-protective package that contains the hot-swap power supply to any unpainted metal surface on the server; then, remove the power supply from the package and place it on a static-protective surface.
- Step 3. Turn off the circuit breaker for the dc power source to which the new power supply will be connected. Disconnect the power cord from the dc power source.
- Step 4. Attach the dc power cable to the new power supply.

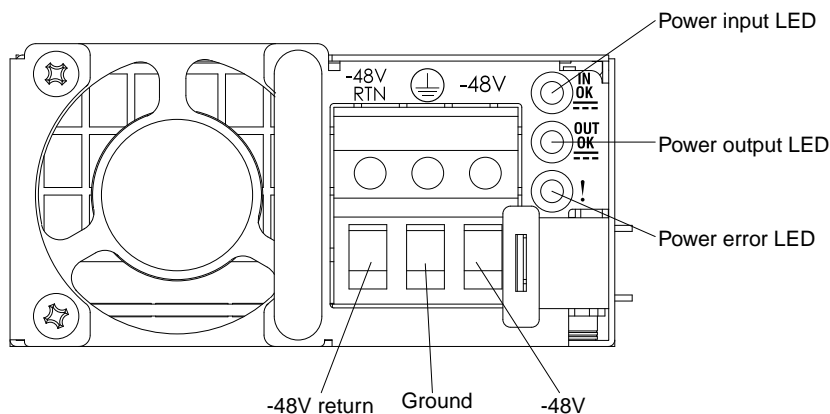

Figure 190. DC power supply rear view

- Step 5. If you are installing a hot-swap power supply into an empty bay, remove the power-supply filler from the power-supply bay.

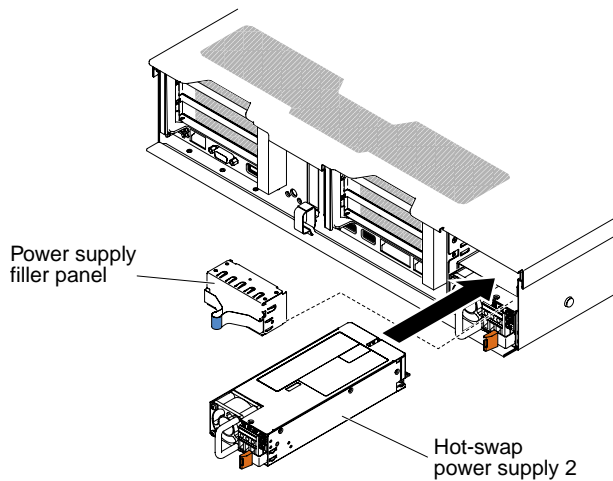

Figure 191. Power supply installation

- Step 6. Grasp the handle on the rear of the power supply and slide the power supply forward into the power-supply bay until it clicks. Make sure that the power supply connects firmly into the power-supply connector.
- Step 7. Route the power cord through the handle and cable tie if any, so that it does not accidentally become unplugged.
- Step 8. Connect the other ends of the dc power cable to the dc power source. Cut the wires to the correct length, but do not cut them shorter than 150 mm (6 inch). If the power source requires ring terminals, you must use a crimping tool to install the ring terminals to the power cord wires. The ring terminals must be UL approved and must accommodate the wires that are described on page “Replacing a hot-swap dc power supply” on page 236. The minimum nominal thread diameter of a pillar or stud type of terminal must be 4 mm; for a screw type of terminal the diameter must be 5.0 mm.
- Step 9. Turn on the circuit breaker for the dc power source to which the new power supply is connected.
- Step 10. Make sure that the green power LEDs on the power supply are lit, indicating that the power supply is operating correctly.
- Step 11. If you are replacing a power supply to the server, attach the redundant power information label that comes with this option on the server cover near the power supplies.

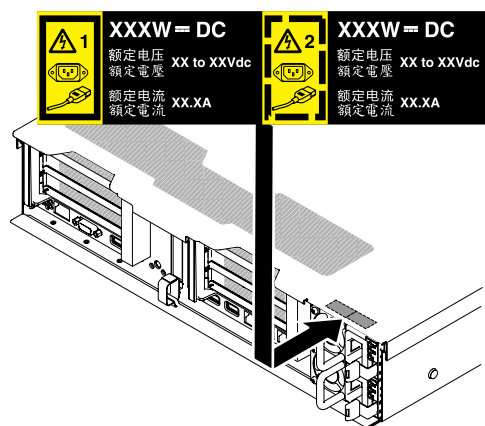

Figure 192. Redundant power information label

## Removing the 2.5-inch simple-swap backplate assembly/hot-swap hard disk drive backplane

Use this information to remove the 2.5-inch simple-swap backplate assembly/hot-swap hard disk drive backplane.

To remove the 2.5-inch simple-swap backplate assembly/hot-swap hard disk drive backplane, complete the following steps:

- Step 1. Read the safety information that begins on “Safety” on page v and “Installation guidelines” on page 287.
- Step 2. Turn off the server and peripheral devices and disconnect the power cords and all external cables, if necessary.
- Step 3. Remove the top cover (see “Removing the top cover” on page 144).
- Step 4. Pull the hard disk drives or fillers out of the server slightly to disengage them from the backplate assembly/backplane. See “Removing a hot-swap hard disk drive” on page 153 and “Removing a simple-swap hard disk drive” on page 156 for details.
- Step 5. To obtain more working room, remove the fan cage assembly (see “Removing the fan cage assembly” on page 172).
- Step 6. Lift the two front release latches and rotate the backplate assembly/backplane toward the rear of the server to remove the backplate assembly/backplane.

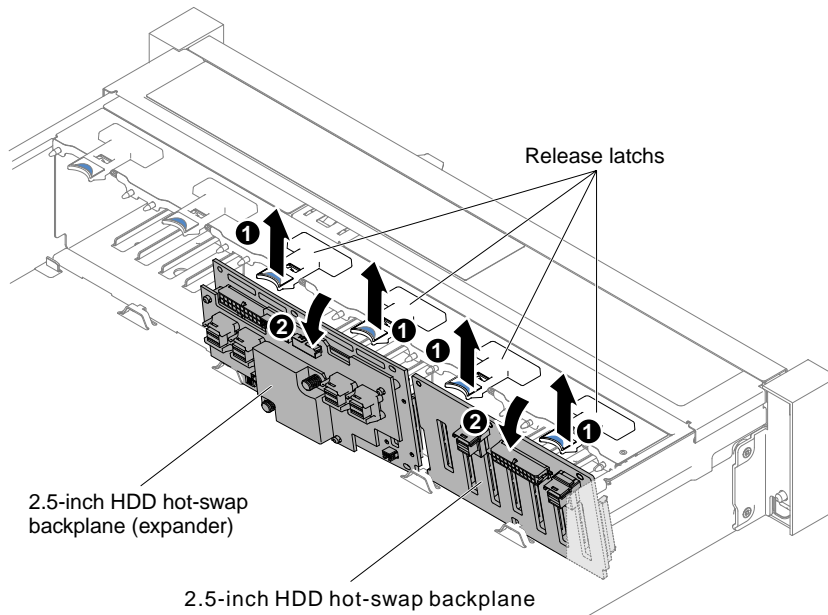

Figure 193. 2.5-inch simple-swap backplate assembly/hot-swap hard disk drive backplane removal

- Step 7. Disconnect all cables from the hard disk drive backplane and the system board.

**Note:** Disengage all latches, release tabs or locks on cable connectors when you disconnect all cables from the system board. Failing to release them before removing the cables will damage the cable sockets on the system board. The cable sockets on the system board are fragile. Any damage to the cable sockets may require replacing the system board.

- Step 8. If you are instructed to return the hard disk drive backplate assembly/backplane, follow all packaging instructions, and use any packaging materials for shipping that are supplied to you.

## Replacing the 2.5-inch simple-swap backplate assembly/hot-swap hard disk drive backplane

Use this information to replace the 2.5-inch simple-swap backplate assembly/hot-swap hard disk drive backplane.

To install the 2.5-inch simple-swap backplate assembly/hot-swap hard disk drive backplane, complete the following steps:

- Step 1. Read the safety information that begins on “Safety” on page v and “Installation guidelines” on page 287.
- Step 2. Turn off the server, and disconnect all power cords and external cables.
- Step 3. Remove the top cover (see “Removing the top cover” on page 144).
- Step 4. Pull the hard disk drives or fillers out of the server slightly to disengage them from the backplate assembly/backplane. See “Removing a hot-swap hard disk drive” on page 153 and “Removing a simple-swap hard disk drive” on page 156 for details.
- Step 5. Remove the fan cage assembly (see “Removing the fan cage assembly” on page 172).
- Step 6. Insert the backplate assembly/backplane tabs into slots on the bottom of the cage and push the backplate assembly/backplane forward into the release latch (on top of the backplate assembly/backplane cage) until the backplate assembly/backplane is locked in place.

**Note:** You can connect the cables to the drive backplate assembly/backplane before installing the backplate assembly/backplane onto the cage or you can connect the cables after you install the backplate assembly/backplane, if that is easier for you.

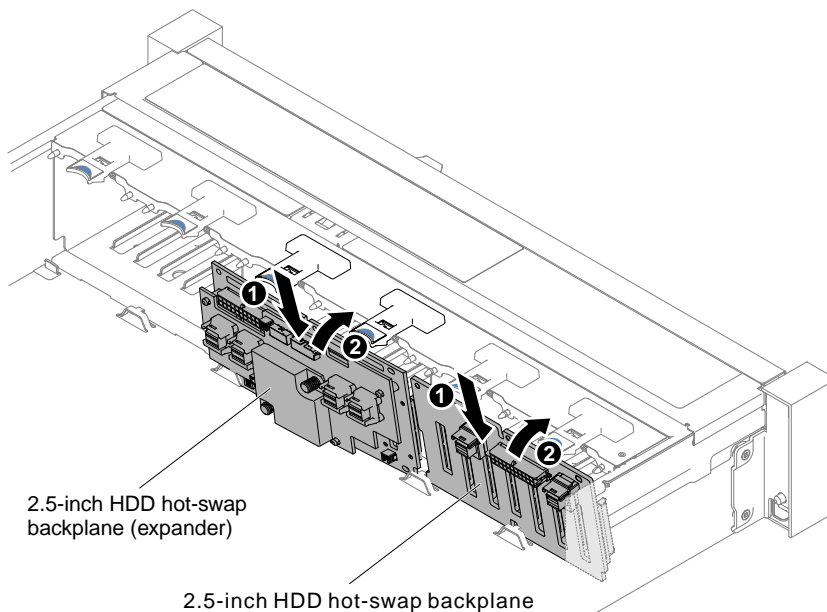

Figure 194. 2.5-inch simple-swap backplate assembly/hot-swap hard disk drive backplane installation

- Step 7. Connect the SAS signal and power/configuration cables to the backplate assembly/backplane and the system board. See “2.5-inch hard disk drive cable connection” on page 132 for details.
- Step 8. Replace the fan cage and fans if you removed them (see “Replacing the fan cage assembly” on page 173 and “Replacing a hot-swap fan” on page 175).
- Step 9. Reinstall the hard disk drives (see “Replacing a hot-swap hard disk drive” on page 154).

- Step 10. Install the top cover (see “Replacing the top cover” on page 146).
- Step 11. Slide the server into the rack.
- Step 12. Reconnect the power cords and any cables that you removed.
- Step 13. Turn on the peripheral devices and the server.

## Removing the 3.5-inch simple-swap backplate assembly/hot-swap hard disk drive backplane

Use this information to remove the 3.5-inch simple-swap backplate assembly/hot-swap hard disk drive backplane.

To remove the 3.5-inch simple-swap backplate assembly/hot-swap hard disk drive backplane, complete the following steps:

- Step 1. Read the safety information that begins on “Safety” on page v and “Installation guidelines” on page 287.
- Step 2. Turn off the server and peripheral devices and disconnect all power cords.
- Step 3. Remove the top cover (see “Removing the top cover” on page 144).
- Step 4. Pull the hard disk drives or fillers out of the server slightly to disengage them from the backplate assembly/backplane. See “Removing a hot-swap hard disk drive” on page 153 and “Removing a simple-swap hard disk drive” on page 156 for details.
- Step 5. To obtain more working room, remove the fan cage assembly (see “Removing the fan cage assembly” on page 172).
- Step 6. Disconnect the SAS signal and power/configuration cables from the system board.

**Note:** Disengage all latches, release tabs or locks on cable connectors when you disconnect all cables from the system board. Failing to release them before removing the cables will damage the cable sockets on the system board. The cable sockets on the system board are fragile. Any damage to the cable sockets may require replacing the system board.

- Step 7. Pull the two plungers while you push the backplate assembly to the left to disengage the assembly.
  - For eight 3.5-inch simple-swap backplate assembly/hot-swap hard disk drive backplane

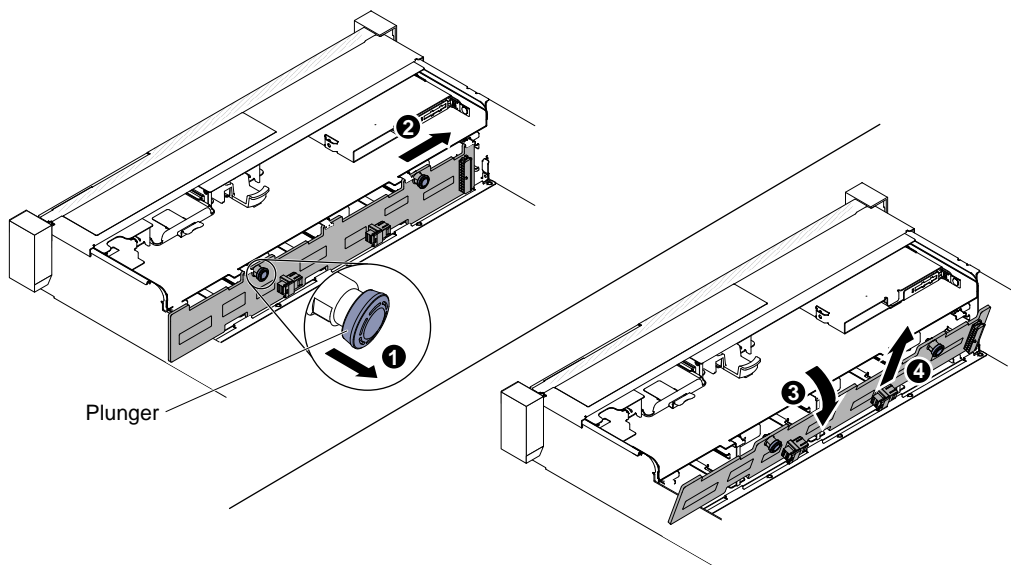

Figure 195. 3.5-inch simple-swap backplate assembly/hot-swap hard disk drive backplane removal

- For twelve 3.5-inch hot-swap hard disk drive backplane

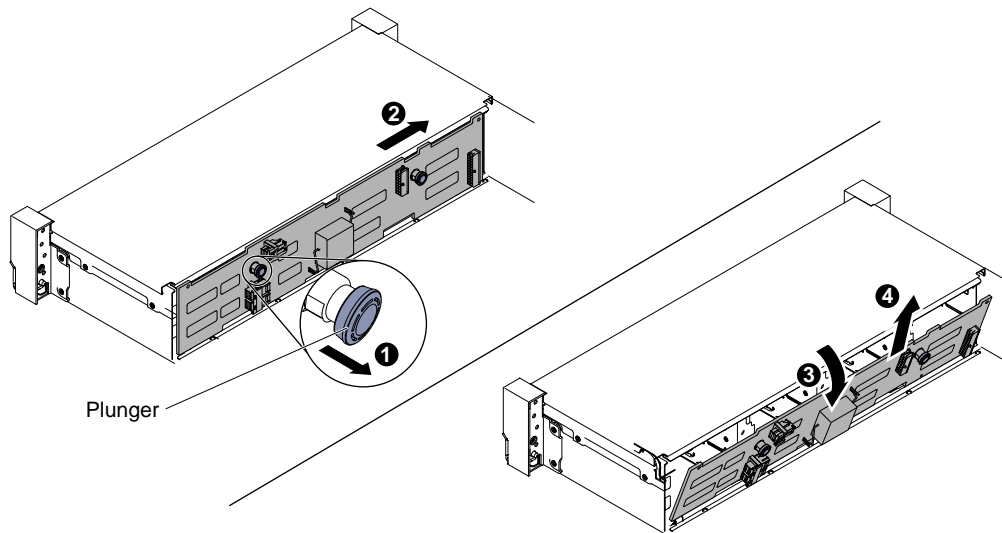

Figure 196. 3.5-inch hot-swap hard disk drive backplane removal

- Step 8. Rotate the backplate assembly/backplane toward the rear of the server and lift the backplate assembly/backplane up to remove it from the server.
- Step 9. If you are instructed to return the hard disk drive backplate assembly/backplane, follow all packaging instructions, and use any packaging materials for shipping that are supplied to you.

## Replacing the 3.5-inch simple-swap backplate assembly/hot-swap hard disk drive backplane

Use this information to replace the 3.5-inch simple-swap backplate assembly/hot-swap hard disk drive backplane.

To install the 3.5-inch simple-swap backplate assembly/hot-swap hard disk drive backplane, complete the following steps:

- Step 1. Read the safety information that begins on “Safety” on page v and “Installation guidelines” on page 287.
- Step 2. Turn off the server, and disconnect all power cords and external cables.
- Step 3. Remove the top cover (see “Removing the top cover” on page 144).
- Step 4. Pull the hard disk drives or fillers out of the server slightly to disengage them from the backplate assembly/backplane. See “Removing a hot-swap hard disk drive” on page 153 and “Removing a simple-swap hard disk drive” on page 156 for details.
- Step 5. Remove the fan cage assembly (see “Removing the fan cage assembly” on page 172).
- Step 6. **1** Insert the backplate assembly/backplane tabs into slots on the bottom of the drive cage at an angle; then, **2** rotate the backplate assembly/backplane toward the front the server.
- Note:** You can connect the cables to the drive backplate assembly/backplane before installing the backplate assembly/backplane onto the cage or you can connect the cables after you install the backplate assembly/backplane, if that is easier for you.
- Step 7. **3** Push the backplate assembly/backplane to the left to engage the assembly into place.



- For eight 3.5-inch simple-swap backplate assembly/hot-swap hard disk drive backplane

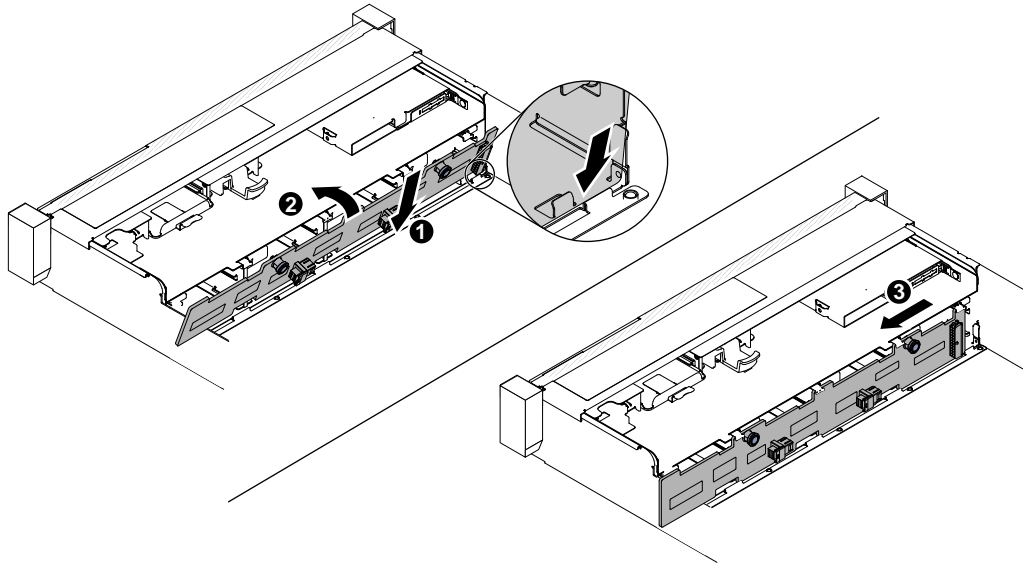

Figure 197. Eight 3.5-inch simple-swap backplate assembly/hot-swap hard disk drive backplane

- For twelve 3.5-inch hot-swap hard disk drive backplane

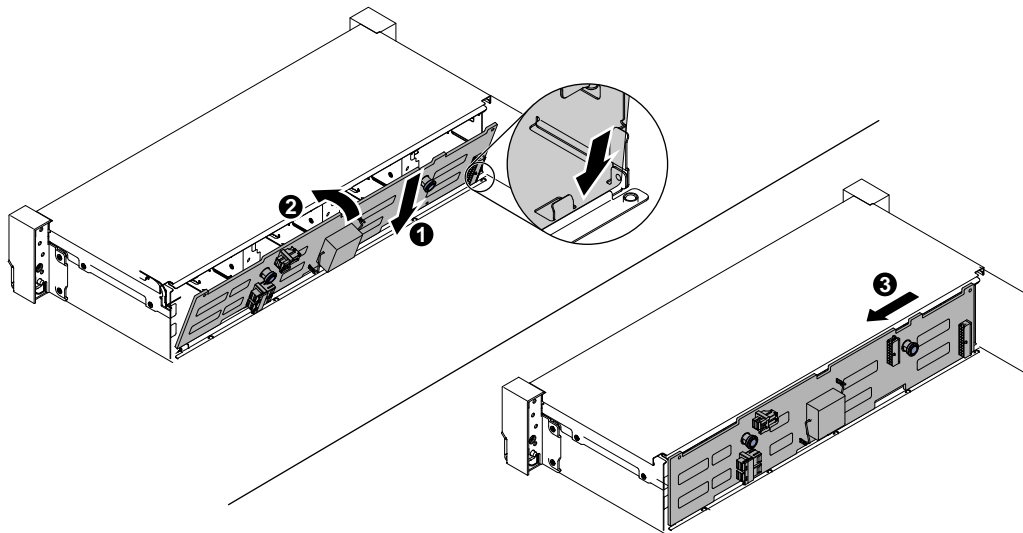

Figure 198. 3.5-inch hot-swap hard disk drive backplane installation

- Step 8. Connect the signal and power-configuration cables to the backplane and the system board. See “3.5-inch hard disk drive cable connection” on page 141 for more information.
- Step 9. Reinstall the hard disk drives and filler panels (see “Replacing a simple-swap hard disk drive” on page 157).
- Step 10. Replace the fan cage assembly and fans if you removed them (see “Replacing the fan cage assembly” on page 173 and “Replacing a hot-swap fan” on page 175).
- Step 11. Install the top cover (see “Replacing the top cover” on page 146).
- Step 12. Slide the server into the rack.

Step 13. Reconnect the power cords and any cables that you removed.

Step 14. Turn on the peripheral devices and the server.

## Removing a USB embedded hypervisor flash device

Use this information to remove a USB embedded hypervisor flash device.

To remove a USB hypervisor flash device, complete the following steps:

Step 1. Read the safety information that begins on “Safety” on page v and “Installation guidelines” on page 287.

Step 2. Turn off the server and peripheral devices and disconnect the power cords.

Step 3. Remove the top cover (see “Removing the top cover” on page 144).

Step 4. Remove the flash device:

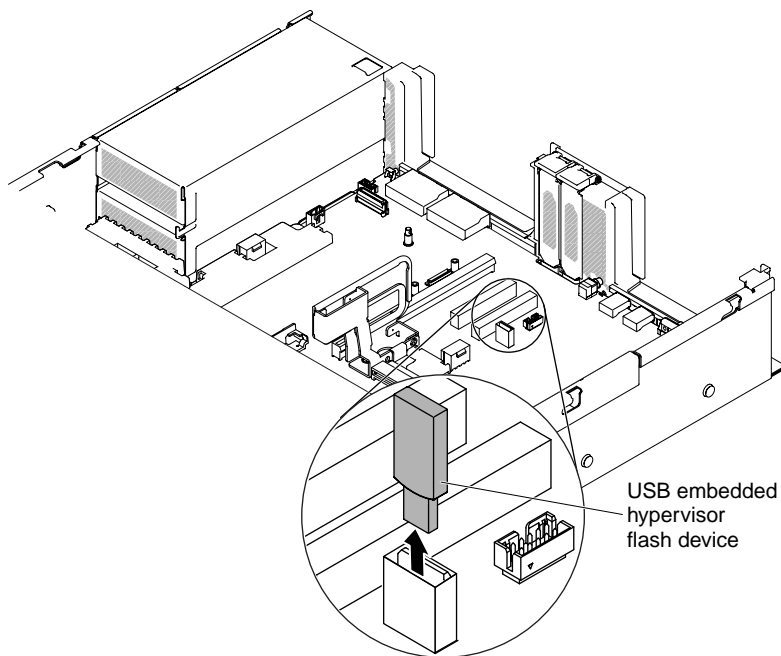

Figure 199. USB hypervisor flash device removal

- a. Unlock the retention latch on the USB connector by pushing down the blue locking collar.
- b. Grasp the flash device and pull to remove it from the connector.

Step 5. If you are instructed to return the flash device, follow all packaging instructions, and use any packaging materials for shipping that are supplied to you.

## Replacing a USB embedded hypervisor flash device

Use this information to replace a USB embedded hypervisor flash device.

To install a USB hypervisor flash device, complete the following steps:

Step 1. Read the safety information that begins on “Safety” on page v and “Installation guidelines” on page 287.

Step 2. Turn off the server and peripheral devices and disconnect the power cords.

- Step 3. Remove the top cover (see “Removing the top cover” on page 144).
- Step 4. Remove the riser-card assembly (see “Removing a riser-card assembly” on page 180).
- Step 5. Install the flash device:

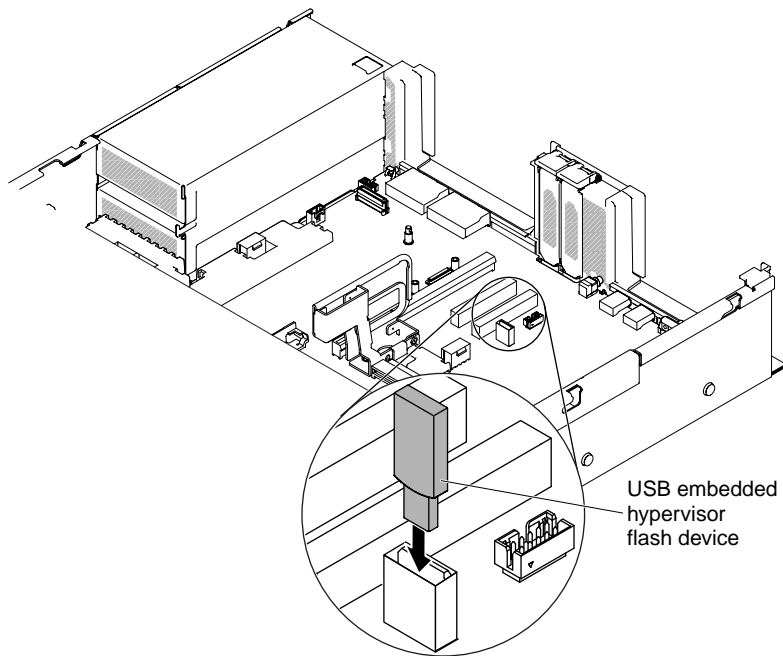

Figure 200. USB hypervisor flash device installation

- a. Align the flash device with the connector on the system board and push it into the USB connector until it is firmly seated.
- b. Pull up the blue locking collar to lock the flash device into the USB connector.

- Step 6. Reconnect the power cords and any cables that you removed.
- Step 7. Replace the top cover (see “Replacing the top cover” on page 146).
- Step 8. Slide the server into the rack.
- Step 9. Turn on the peripheral devices and the server.

## Removing the coin-cell battery (also called CMOS battery)

The following notes describe information that you must consider when replacing the battery.

- Lenovo has designed this product with your safety in mind. The lithium battery must be handled correctly to avoid possible danger. If you replace the battery, you must adhere to the following instructions.

**Note:** In the U. S., call 1-800-IBM-4333 for information about battery disposal.

- If you replace the original lithium battery with a heavy-metal battery or a battery with heavy-metal components, be aware of the following environmental consideration. Batteries and accumulators that contain heavy metals must not be disposed of with normal domestic waste. They will be taken back free of charge by the manufacturer, distributor, or representative, to be recycled or disposed of in a proper manner.
- To order replacement batteries, call 1-800-IBM-SERV within the United States, and 1-800-465-7999 or 1-800-465-6666 within Canada. Outside the U.S. and Canada, call your support center or business partner.

**Note:** After you replace the battery, you must reconfigure the server and reset the system date and time.

## Statement 2



### **CAUTION:**

**When replacing the lithium battery, use only Part Number 33F8354 or an equivalent type battery recommended by the manufacturer. If your system has a module containing a lithium battery, replace it only with the same module type made by the same manufacturer. The battery contains lithium and can explode if not properly used, handled, or disposed of.**

*Do not:*

- **Throw or immerse into water**
- **Heat to more than 100°C (212°F)**
- **Repair or disassemble**

**Dispose of the battery as required by local ordinances or regulations.**

To remove the coin-cell battery, complete the following steps:

- Step 1. Read the safety information that begins on “Safety” on page v and “Installation guidelines” on page 287.
- Step 2. Turn off the server and peripheral devices and disconnect the power cords and all external cables, if necessary.
- Step 3. Remove the top cover (see “Removing the top cover” on page 144).
- Step 4. If necessary, lift the riser-card assembly 2 out of the way (see “Removing a riser-card assembly” on page 180).
- Step 5. Remove the coin-cell battery:

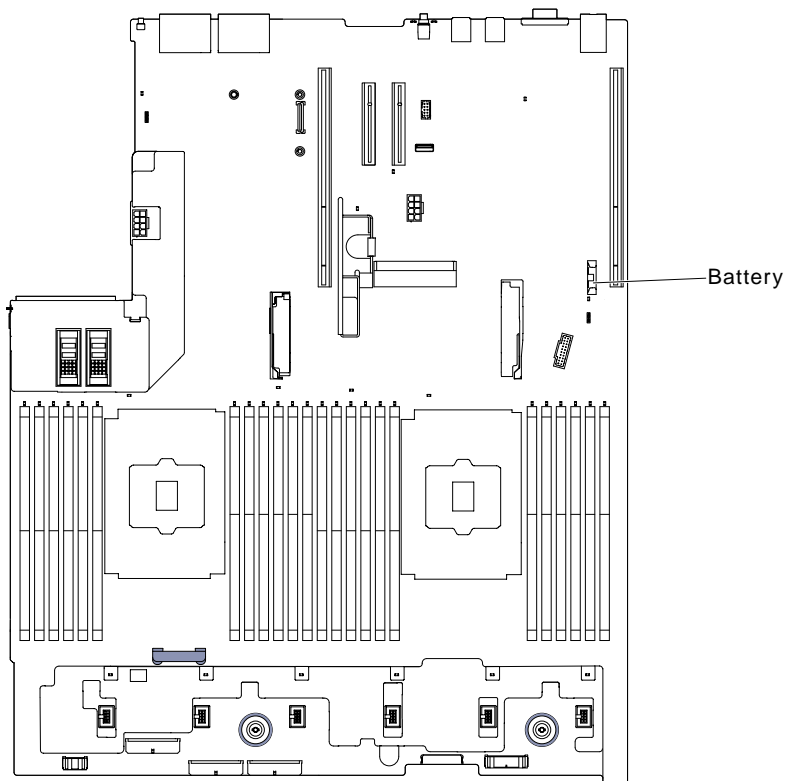

Figure 201. Coin-cell battery position

- a. If there is a rubber cover on the battery holder, use your fingers to lift the battery cover from the battery connector.
- b. Use one finger to tilt the battery horizontally out of its socket, pushing it away from the socket.

**Attention:** Neither tilt nor push the battery by using excessive force.

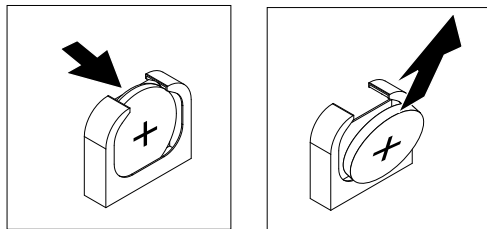

Figure 202. Coin-cell battery removal

- c. Use your thumb and index finger to lift the battery from the socket.

**Attention:** Do not lift the battery by using excessive force. Failing to remove the battery properly may damage the socket on the system board. Any damage to the socket may require replacing the system board.

Step 6. Dispose of the battery as required by local ordinances or regulations. See the *Environmental Notices and User's Guide* on the *Documentation CD* for more information.

## Replacing the coin-cell battery (also called CMOS battery)

The following notes describe information that you must consider when replacing the coin-cell battery in the server.

- When replacing the coin-cell battery, you must replace it with a lithium battery of the same type from the same manufacturer.
- To order replacement batteries, call 1-800-426-7378 within the United States, and 1-800-465-7999 or 1-800-465-6666 within Canada. Outside the U.S. and Canada, call your sales representative or reseller.
- After you replace the system-board battery, you must reconfigure the server and reset the system date and time.
- To avoid possible danger, read and follow the following safety statement.

### Statement 2



#### CAUTION:

**When replacing the lithium battery, use only Part Number 33F8354 or an equivalent type battery recommended by the manufacturer. If your system has a module containing a lithium battery, replace it only with the same module type made by the same manufacturer. The battery contains lithium and can explode if not properly used, handled, or disposed of.**

*Do not:*

- **Throw or immerse into water**
- **Heat to more than 100°C (212°F)**
- **Repair or disassemble**

**Dispose of the battery as required by local ordinances or regulations.**

To install the replacement coin-cell battery, complete the following steps:

- Step 1. Follow any special handling and installation instructions that come with the replacement battery.
- Step 2. Read the safety information that begins on “Safety” on page v and “Installation guidelines” on page 287.
- Step 3. Turn off the server and peripheral devices and disconnect the power cords and all external cables, if necessary.
- Step 4. Remove the top cover (see “Removing the top cover” on page 144).
- Step 5. If necessary, lift the riser-card assembly 2 out of the way (see “Removing a riser-card assembly” on page 180).
- Step 6. Insert the new battery:

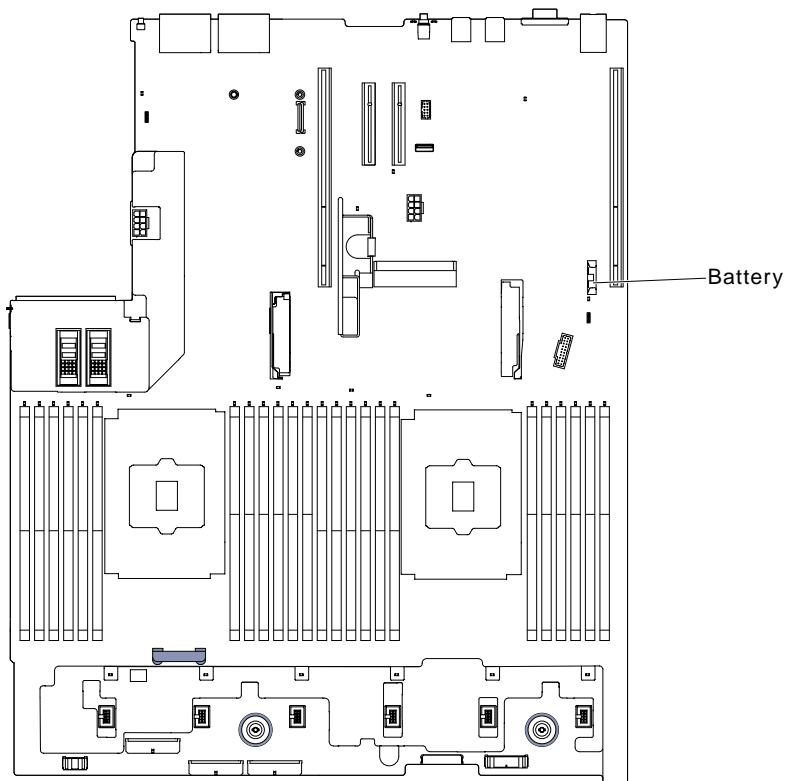

Figure 203. Coin-cell battery position

- a. Tilt the battery so that you can insert it into the socket on the side opposite the battery clip.



Figure 204. Coin-cell battery installation

- b. Press the battery down into the socket until it clicks into place. Make sure that the battery clip holds the battery securely.
- c. If you removed a rubber cover from the battery holder, use your fingers to install the battery cover on top of the battery connector.

- Step 7. Reinstall the riser-card assembly 2 (see “Replacing a riser-card assembly” on page 181), if necessary.
- Step 8. Install the top cover (see “Replacing the top cover” on page 146).
- Step 9. Slide the server into the rack.
- Step 10. Reconnect the external cables; then, reconnect the power cords and turn on the peripheral devices and the server.
- Step 11. Start the Setup Utility and reset the configuration.
  - Set the system date and time.

- Set the power-on password.
- Reconfigure the server.

See “Using the Setup Utility” on page 47 for details.

## Removing the SD adapter

Use this information to remove the SD adapter.

To remove the SD adapter, complete the following steps:

- Step 1. Read the safety information that begins on “Safety” on page v and “Installation guidelines” on page 287.
- Step 2. Remove the top cover (see “Removing the top cover” on page 144).
- Step 3. Remove the riser-card assembly 2, if needed (See “Removing a riser-card assembly” on page 180).
- Step 4. Loosen two screws.
- Step 5. Lift the SD adapter out of the server.
- Step 6. Remove the SD cards.

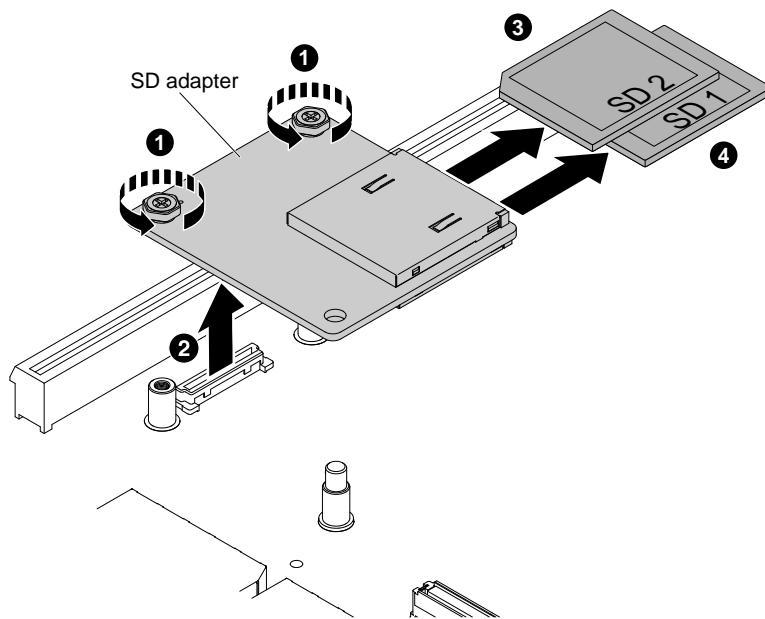

Figure 205. SD adapter removal

- Step 7. If you are instructed to return the SD adapter, follow all packaging instructions, and use any packaging materials for shipping that are supplied to you.

## Replacing the SD adapter

Use this information to replace a SD adapter.

**Important:** If your SD adapter option comes with VMware vSphere ESXi software preloaded, you must make configuration changes to your system UEFI *before* installing the SD adapter in your compute node. See the documentation that comes with the SD adapter and “Using the Setup Utility” on page 47 for information and instructions.



To install the SD adapter, complete the following steps:

- Step 1. Read the safety information that begins on “Safety” on page v and “Installation guidelines” on page 287.
- Step 2. Turn off the server, and disconnect all power cords and external cables.
- Step 3. Remove the top cover (see “Removing the top cover” on page 144).
- Step 4. Remove the riser-card assembly 2 (See “Removing a riser-card assembly” on page 180).
- Step 5. Insert the SD cards.
- Step 6. Align the SD adapter with the alignment pin and the connector; then, lower the SD adapter and push it until it is firmly seated.
- Step 7. Fasten two screws.

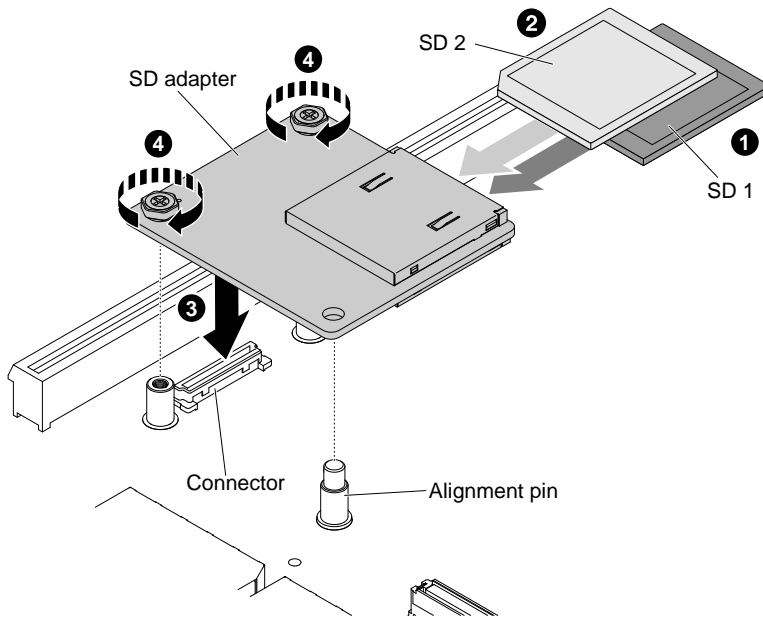

Figure 206. SD adapter installation

- Step 8. See the <http://www.ibm.com/support/entry/portal/docdisplay?Indocid=MIGR-5096845>, that comes with the option, for information about how to configure the SD adapter.
- Step 9. Turn on the peripheral devices and the server.

## Removing the LCD system information display panel

Use this information to remove the LCD system information display panel.

**Note:** The LCD system information display panel is available only on some models.

### Removing the LCD panel assembly on a 3.5-inch model

To remove the LCD panel assembly on a 3.5-inch model, complete the following steps.

1. Read the safety information that begins on “Safety” on page v and “Installation guidelines” on page 287.
2. Turn off the server and peripheral devices and disconnect the power cords and all external cables, if necessary.
3. Remove the top cover (see “Removing the top cover” on page 144).

4. Remove the fan cage assembly (See “Removing the fan cage assembly” on page 172).
5. Pull up the release latch slightly and slide the LCD panel assembly out of the server.

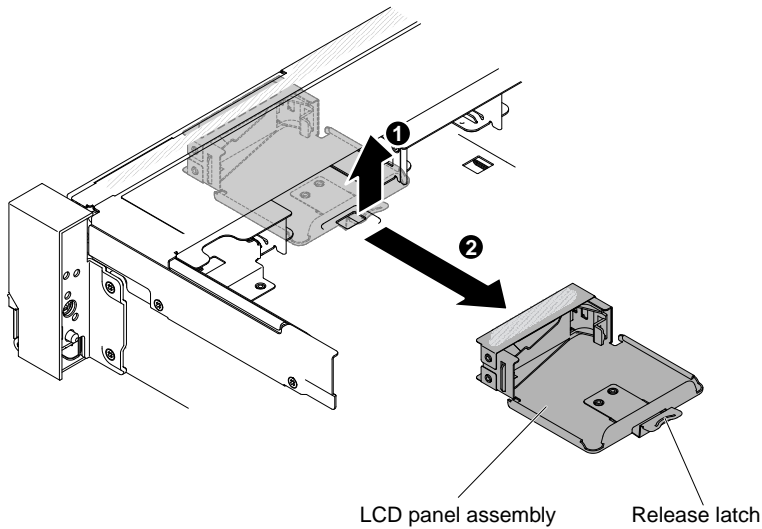

Figure 207. LCD panel assembly removal

6. Disconnect the cable from the back of the LCD system information display panel.

**Note:** To disconnect the cable, press evenly on the connector release latch first; then, pull the cable out.

7. 1 Pull the tab on the LCD retention bracket to the left to disengage the retention bracket. 2 Rotate the retention bracket to remove it from the server.

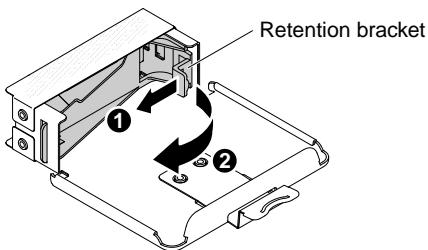

Figure 208. Retention bracket removal

8. Carefully remove the LCD system information display panel out of the LCD panel assembly.

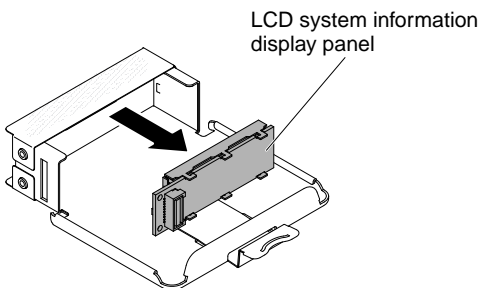

Figure 209. LCD system information display panel removal

9. If you are instructed to return the LCD panel assembly, follow all packaging instructions, and use any packaging materials for shipping that are supplied to you.

### Removing the LCD system information display panel on a 2.5-inch model

To remove the LCD system information display panel inside the media cage on a 2.5-inch model, complete the following steps.

1. Read the safety information that begins on “Safety” on page v and “Installation guidelines” on page 287.
2. Turn off the server and peripheral devices and disconnect the power cords and all external cables, if necessary.
3. Remove the top cover (see “Removing the top cover” on page 144).
4. Remove the fan cage assembly “Removing the fan cage assembly” on page 172).
5. Remove the media cage (see “Removing the media cage (also called lightpath LCD operation panel assembly)” on page 176),
6. Disconnect the cable from the back of the LCD system information display panel.

**Note:** To disconnect the cable, press evenly on the connector release latch first; then, pull the cable out.

7. **1** Pull the tab on the LCD retention bracket to the left to disengage the retention bracket. **2** Rotate the retention bracket to remove it from the server.

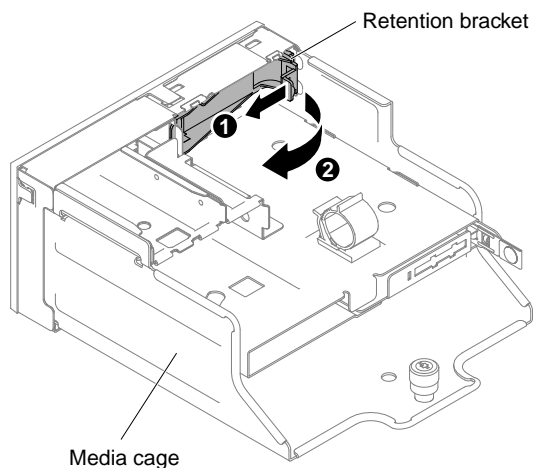

Figure 210. Retention bracket removal

8. Carefully remove the LCD system information display panel out of the media cage.

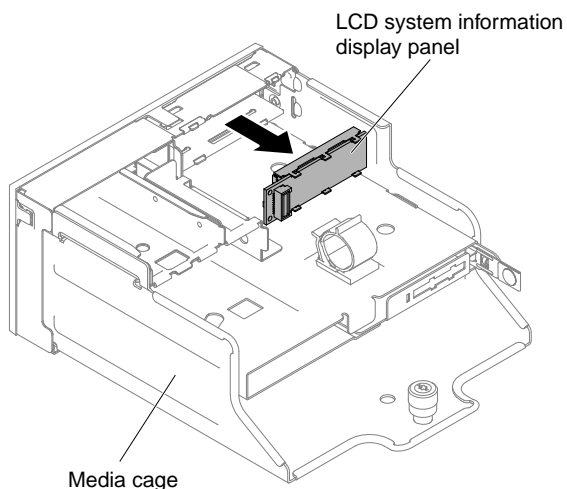

Figure 211. LCD system information display panel removal

9. If you are instructed to return the LCD system information display panel, follow all packaging instructions, and use any packaging materials for shipping that are supplied to you.

## Replacing the LCD system information display panel

Use this information to replace the LCD system information display panel.

**Note:** The LCD system information display panel is available on some models.

### Replacing the LCD panel assembly on a 3.5-inch model

To install the LCD panel assembly on a 3.5-inch model, complete the following steps.

1. Read the safety information that begins on “Safety” on page v and “Installation guidelines” on page 287.
2. Turn off the server and peripheral devices and disconnect the power cords and all external cables, if necessary.
3. Remove the top cover (see “Removing the top cover” on page 144).
4. Remove the fan cage assembly “Removing the fan cage assembly” on page 172).
5. **1** Pull the tab on the LCD retention bracket to the left to disengage the retention bracket. **2** Rotate the retention bracket to remove it from the server.

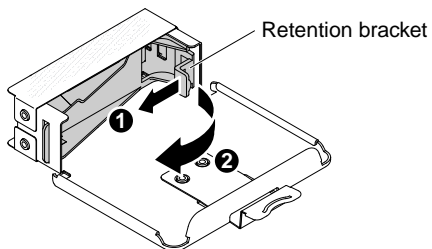

Figure 212. Retention bracket removal

6. Carefully insert the LCD system information display panel into place.

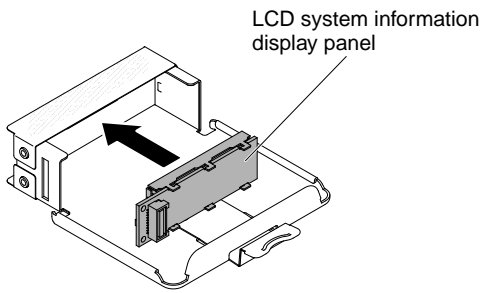

Figure 213. LCD system information display panel installation

7. Hinge the retention bracket into the slot on the LCD panel assembly and rotate it until it clicks into place.

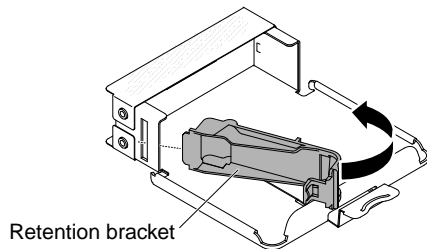

Figure 214. Retention bracket installation

8. Connect the cable to the rear of the LCD system information display panel.
9. Slide the LCD panel assembly into the server until it clicks into place.

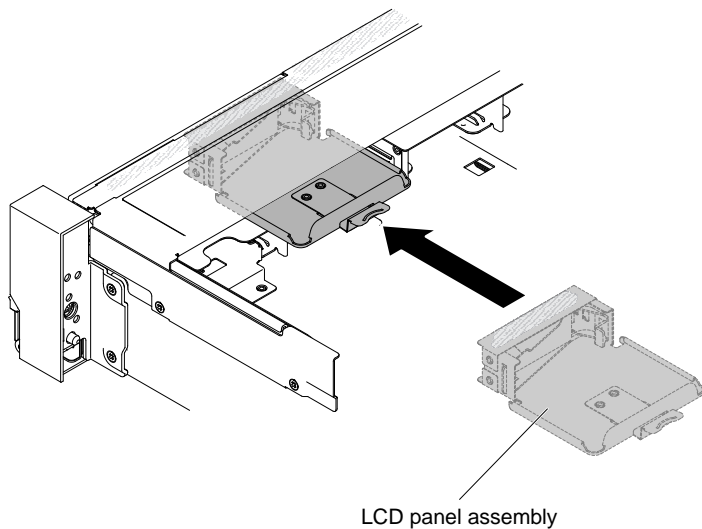

Figure 215. LCD panel assembly installation

10. Connect the LCD panel assembly cable to the system board. The following illustration shows the cable routing for the LCD panel assembly.

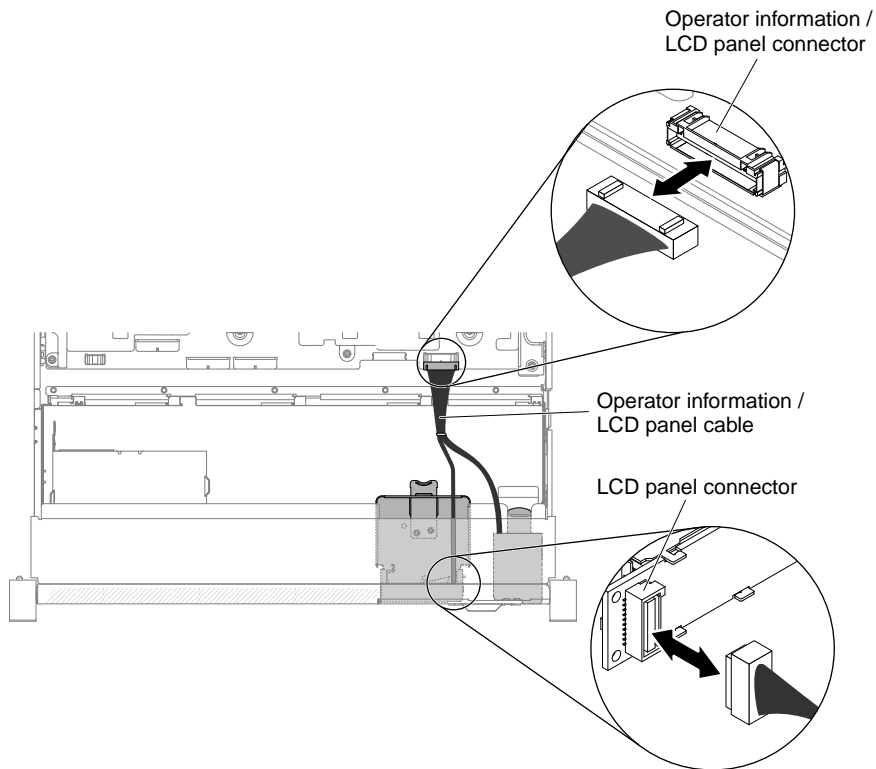

Figure 216. LCD panel assembly cable routing

**Note:** To connect the LCD panel assembly cable on the system board, press evenly on the cable. Pressing on one side of the cable might cause damage to the cable or connector.

11. Replace the top cover (see “Replacing the top cover” on page 146).
12. Slide the server into the rack.
13. Reconnect the power cords and any cables that you removed.
14. Turn on the peripheral devices and the server.

### Replacing the LCD system information display panel on a 2.5-inch model

To install the LCD system information display panel into a media cage that is pre-configured without a LCD system information display panel on a 2.5-inch model, complete the following steps.

1. Read the safety information that begins on “Safety” on page v and “Installation guidelines” on page 287.
2. Turn off the server and peripheral devices and disconnect the power cords and all external cables, if necessary.
3. Remove the top cover (see “Removing the top cover” on page 144).
4. Remove the fan cage assembly “Removing the fan cage assembly” on page 172).
5. Remove the media cage (see “Removing the media cage (also called lightpath LCD operation panel assembly)” on page 176),
6. A separate bezel is needed if your media cage has a bezel without the opening and buttons for the LCD panel, To remove the media cage bezel, complete the following steps:
  - a. Disengage the three snaps on the media cage bezel from the media cage. The following illustration shows the location of three snaps.

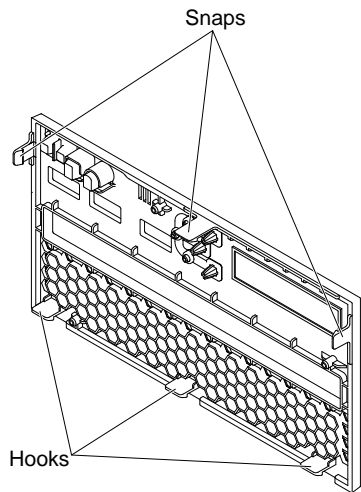

Figure 217. Snaps (the rear side of the media cage)

- b. Lift the bezel upwards; then, pivot and rotate the bezel along the hooks to remove it from the media cage.

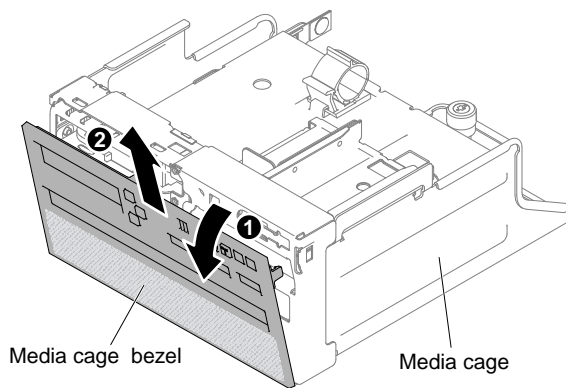

Figure 218. Media cage bezel removal

7. **1** Pull the tab on the LCD retention bracket to the left to disengage the retention bracket. **2** Rotate the retention bracket to remove it from the server.

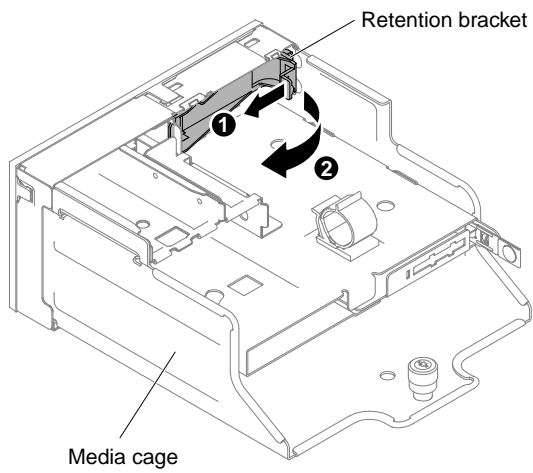

Figure 219. Retention bracket removal

8. Carefully insert the LCD system information display panel into place.

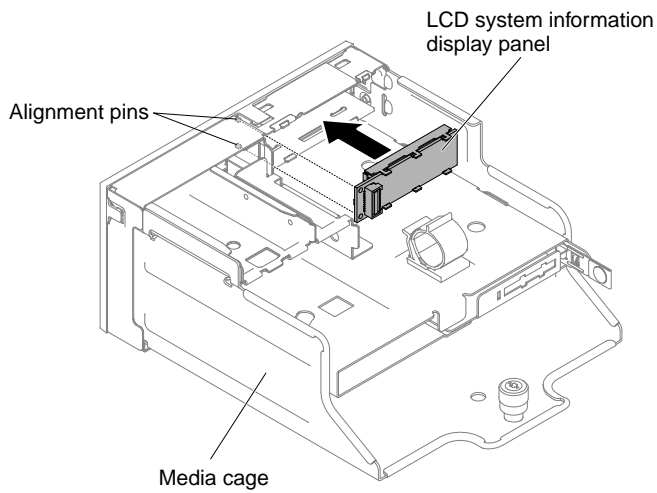

Figure 220. LCD system information display panel installation

9. Insert the retention bracket into the slot on the media cage and push it until it clicks into place.



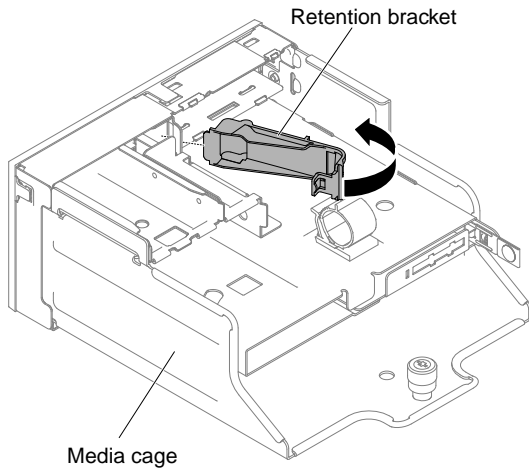

Figure 221. Retention bracket installation

10. If you have removed the media cage bezel, install the new media cage bezel with LCD opening and buttons. Angle the media cage bezel and insert the three hooks on the rear side of the media cage bezel into slots on the media cage. The following illustration shows the location of three hooks.

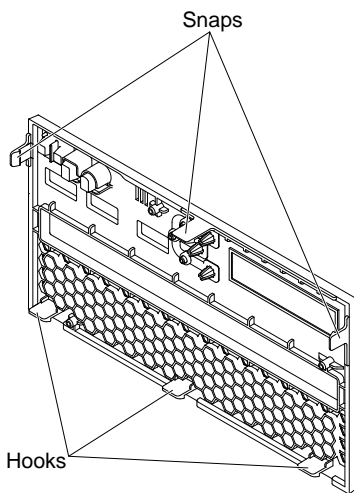

Figure 222. Hooks (the rear side of the media cage)

11. Rotate the media cage bezel and snap it into place.

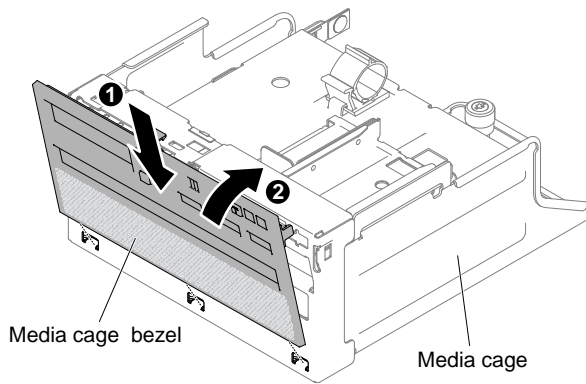

Figure 223. Retention bracket installation

12. Install the media cage (see “Replacing the media cage (also called lightpath LCD operation panel assembly)” on page 178).
13. Replace the top cover (see “Replacing the top cover” on page 146).
14. Slide the server into the rack.
15. Reconnect the power cords and any cables that you removed.
16. Turn on the peripheral devices and the server.

## Removing the operator information panel assembly

Use this information to remove the operator information panel assembly.

To remove the operator information panel, complete the following steps.

- Step 1. Read the safety information that begins on “Safety” on page v and “Installation guidelines” on page 287.
- Step 2. Turn off the server and peripheral devices and disconnect the power cords and all external cables, if necessary.
- Step 3. Remove the top cover (see “Removing the top cover” on page 144).
- Step 4. Disconnect the cable from the back of the operator information panel assembly.
- Step 5. **1** Pull up the release tab slightly and **2** slide the operator information panel assembly out of the server.

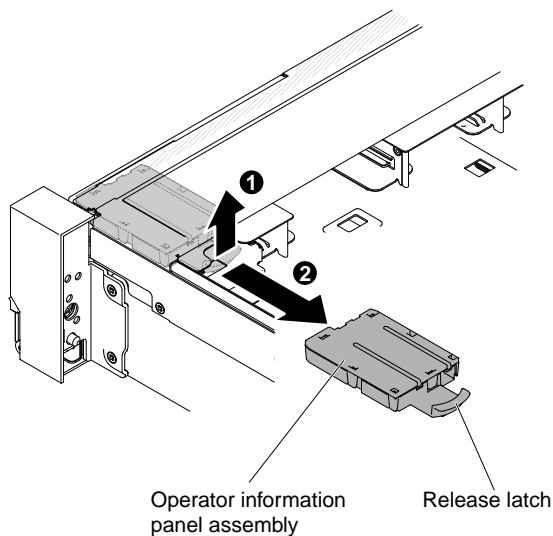

Figure 224. Operator information panel removal

Step 6. If you are instructed to return the operator information panel assembly, follow all packaging instructions, and use any packaging materials for shipping that are supplied to you.

## Replacing the operator information panel assembly

Use this information to replace the operator information panel assembly.

To install the operator information panel, complete the following steps.

- Step 1. Read the safety information that begins on “Safety” on page v and “Installation guidelines” on page 287.
- Step 2. Turn off the server and peripheral devices and disconnect the power cords and all external cables, if necessary.
- Step 3. Remove the top cover (see “Removing the top cover” on page 144).
- Step 4. Slide the operator information panel into the server until it clicks into place.

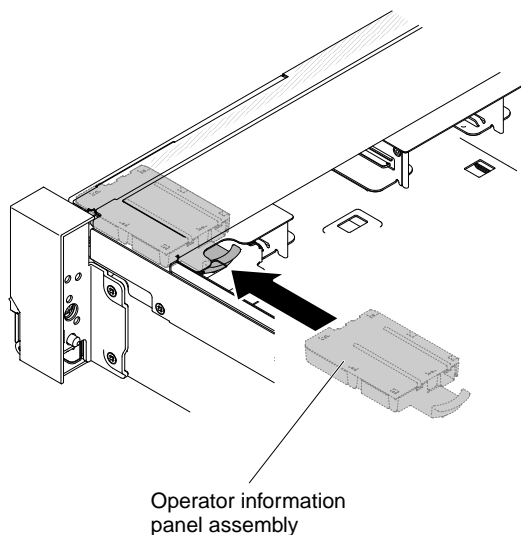

Figure 225. Operator information panel installation

Step 5. Inside the server, connect the operator information panel assembly cable to the system board.

The following illustration shows the cable routing for the operator information panel.

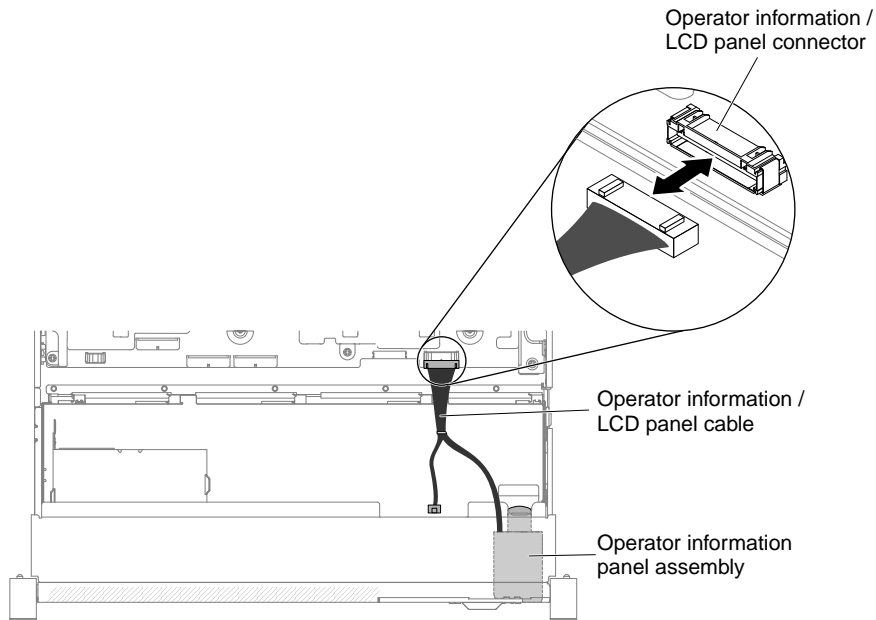

Figure 226. Operator information panel cable routing

**Note:** To connect the operator information panel cable on the system board, press evenly on the cable. Pressing on one side of the cable might cause damage to the cable or connector.

- Step 6. Replace the top cover (see “Replacing the top cover” on page 146).
- Step 7. Slide the server into the rack.
- Step 8. Reconnect the power cords and any cables that you removed.
- Step 9. Turn on the peripheral devices and the server.

## Removing the security bezel

Use this information to remove the security bezel.

To remove the security bezel, complete the following steps.

- Step 1. Read the safety information that begins on “Safety” on page v and “Installation guidelines” on page 287.
- Step 2. Unlock the security bezel, if needed.
- Step 3. **1** Press the release latch and **2** rotate the security bezel to disengage the security bezel from the chassis.

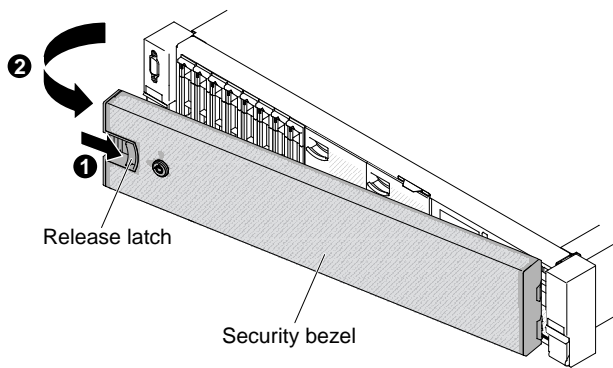

Figure 227. Security bezel removal

Step 4. If you are instructed to return the security bezel, follow all packaging instructions, and use any packaging materials for shipping that are supplied to you.

## Replacing the security bezel

Use this information to replace the security bezel.

To replace the security bezel, complete the following steps:

- Step 1. Read the safety information that begins on “Safety” on page v and “Installation guidelines” on page 287.
- Step 2. **1** Carefully insert the right end of the security bezel into the slots along the right side of the chassis.
- Step 3. **2** Rotate the security bezel until the other side clicks into place on the chassis.

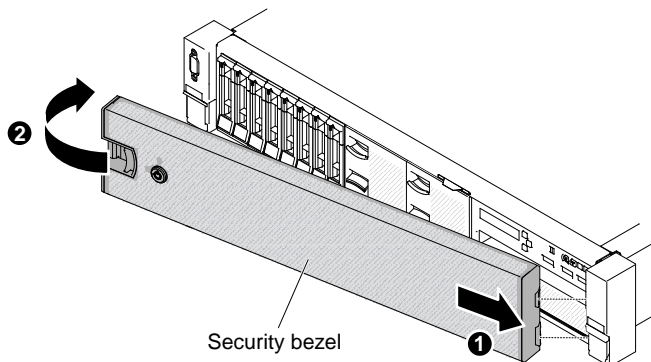

Figure 228. Security bezel installation

Step 4. Use the key to lock the bezel if required.

---

## Removing and replacing Tier 2 CRUs

You may install a Tier 2 CRU yourself or request Lenovo to install it, at no additional charge, under the type of warranty service that is designated for your server.

The illustrations in this document might differ slightly from your hardware.

## Removing a microprocessor and heat sink

Use this information to remove a microprocessor and heat sink.

**Attention:**

- Microprocessors are to be removed only by trained technicians.

**Important:** Always use the microprocessor installation tool to remove a microprocessor. Failing to use the microprocessor installation tool may damage the microprocessor sockets on the system board. Any damage to the microprocessor sockets may require replacing the system board.

- Do not allow the thermal grease on the microprocessor and heat sink to come in contact with anything. Contact with any surface can compromise the thermal grease and the microprocessor socket.
- Dropping the microprocessor during installation or removal can damage the contacts.
- Do not touch the microprocessor contacts; handle the microprocessor by the edges only. Contaminants on the microprocessor contacts, such as oil from your skin, can cause connection failures between the contacts and the socket.

Installation tool has two settings for installing two different sizes of microprocessors. The settings that are marked on the tool are “L” for smaller low core microprocessors, and “H” for larger high core microprocessors.

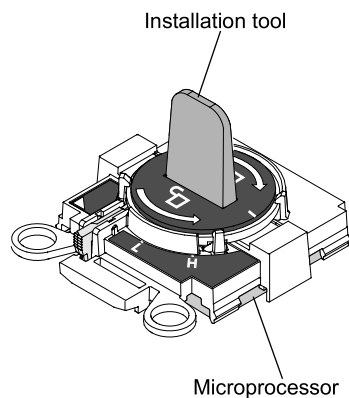

Figure 229. Microprocessor installation tools

To remove a microprocessor and heat sink, complete the following steps:

- Step 1. Read the safety information that begins on “Safety” on page v and “Installation guidelines” on page 287.
- Step 2. Turn off the server and peripheral devices and disconnect all power cords.
- Step 3. Remove the top cover (see “Removing the top cover” on page 144).
- Step 4. Remove the air baffle (see “Removing the air baffle” on page 147).
- Step 5. Locate the microprocessor to be removed (see “System-board internal connectors” on page 28).
- Step 6. If you are removing microprocessor 1, remove the memory modules from DIMM connectors 6 and 7. If you are removing microprocessor 2, remove the memory modules from DIMM connectors 18 and 19. See “Removing a memory module” on page 165 for instructions.
- Step 7. Remove the heat sink.

**Attention:** Do not touch the thermal material on the bottom of the heat sink. Touching the thermal material will contaminate it. If the thermal material on the microprocessor or heat sink becomes contaminated, you must wipe off the contaminated thermal material on the microprocessor or heat sink with the alcohol wipes and reapply clean thermal grease to the heat sink.

- a. Open the heat sink retention module release lever to the fully open position.

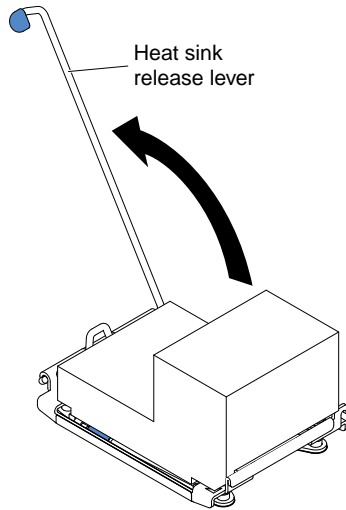

Figure 230. Heat sink retention module release lever

- b. Lift the heat sink out of the server. After removal, place the heat sink (with the thermal grease side up) on a clean, flat surface.

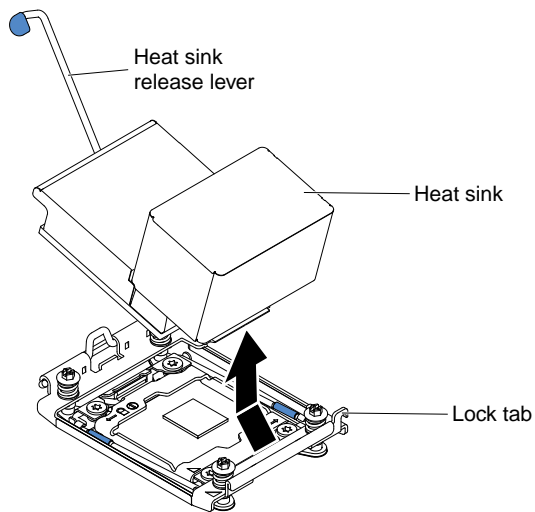

Figure 231. Heat sink removal

Step 8. Open the microprocessor socket release levers and retainer.

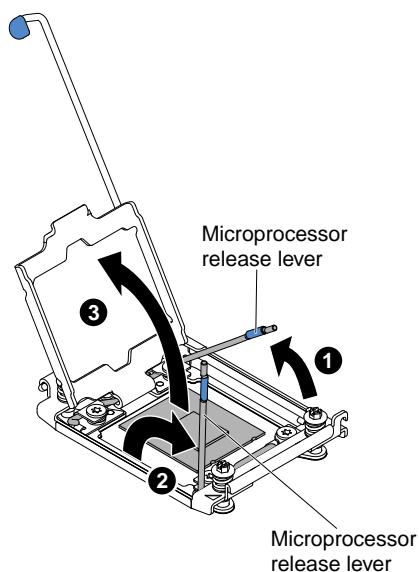

Figure 232. Microprocessor socket levers and retainer disengagement

- a. Identify which release lever is labeled as the first release lever to open and open it.
- b. Open the second release lever on the microprocessor socket.
- c. Open the microprocessor retainer.

**Attention:** Do not touch the microprocessor contacts. Contaminants on the microprocessor contacts, such as oil from your skin, can cause connection failures between the contacts and the socket.

Step 9. Remove the microprocessor from the socket.

- a. Select the empty installation tool and ensure that the handle is in the unlocked position. If the installation tool handle is not in the unlocked position, use the following instructions for your installation tool:
  - **1** lift the interlock latch and hold it up while you **2** twist the microprocessor installation tool handle counterclockwise to the unlocked position, and then release the interlock latch. The following illustration of the installation tool shows the location of the interlock latch and counterclockwise rotation of the handle before loading the microprocessor.

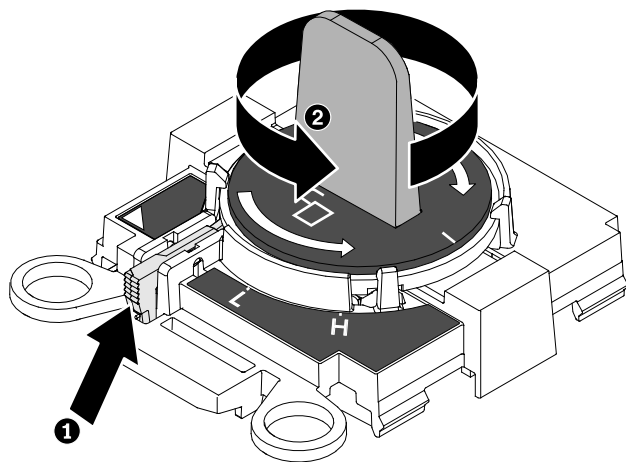

Figure 233. Installation tool handle adjustment



The following illustrations show the installation tool in the locked and unlocked positions.

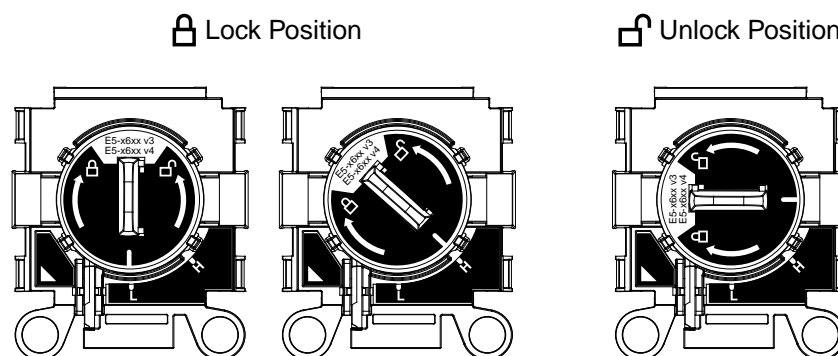

Figure 234. Locked and unlocked positions

- b. Align the installation tool with the screws, as shown in the following graphic, and lower the installation tool on the microprocessor. The installation tool rests flush on the socket only when it is aligned correctly.

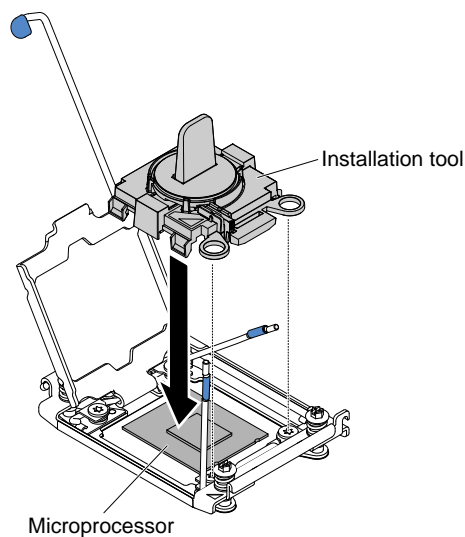

Figure 235. Installation tool alignment

- c. To remove the microprocessor, gently twist the handle of the installation tool clockwise until it locks in the “H” or “L” position, depending on the size of microprocessor, and then lift the microprocessor out of the socket.

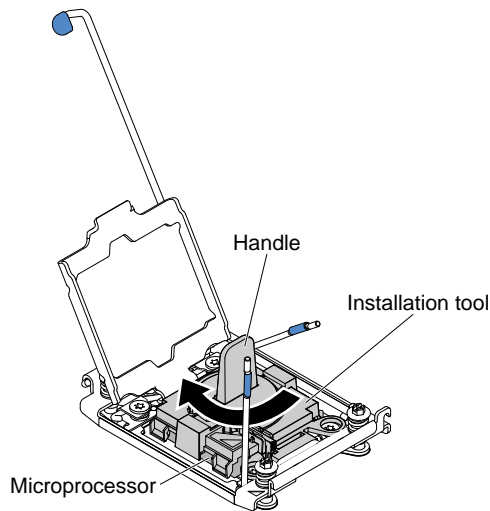

Figure 236. Installation tool handle adjustment

- d. Lift the microprocessor out of the socket.

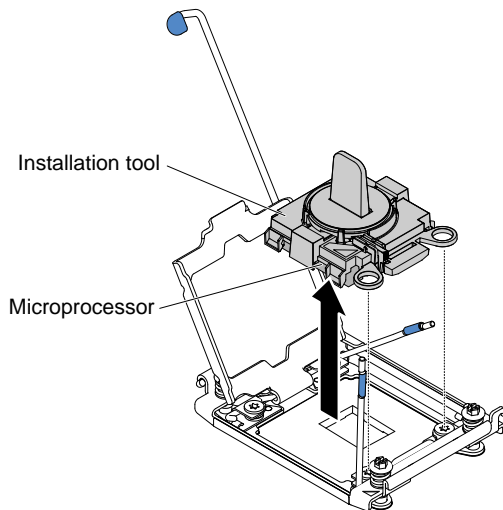

Figure 237. Installation tool removal

Step 10. If you do not intend to install a microprocessor on the socket, install the socket cover that you removed in Step 9 on page 275 on the microprocessor socket.

**Attention:** The pins on the socket are fragile. Any damage to the pins may require replacing the system board.

Step 11. If you are instructed to return the microprocessor, follow all packaging instructions, and use any packaging materials for shipping that are supplied to you.

## Replacing a microprocessor and heat sink

Use this information to replace a microprocessor and heat sink.

The following notes describe the type of microprocessor that the server supports and other information that you must consider when you install a microprocessor and heat sink:

- Microprocessors are to be installed only by trained technicians.

**Important:** Always use the microprocessor installation tool to install a microprocessor. Failing to use the microprocessor installation tool may damage the microprocessor sockets on the system board. Any damage to the microprocessor sockets may require replacing the system board.

- The server supports up to two Intel Xeon™ E5-2600 v4 series multi-core microprocessors, which are designed for the LGA 2011 socket. See <http://www.lenovo.com/serverproven/> for a list of supported microprocessors.
- Do not mix microprocessors with different cores in the same server.
- The first microprocessor must always be installed in microprocessor socket 1 on the system board.
- When one microprocessor is installed, the air baffle must be installed to provide proper system cooling.
- Do not remove the first microprocessor from the system board when you install the second microprocessor.
- When you install the second microprocessor, you must also install additional memory and the fourth fan. See “Installing a memory module” on page 165 for details about the installation sequence.
- To ensure proper server operation when you install an additional microprocessor, use microprocessors that have the same QuickPath Interconnect (QPI) link speed, integrated memory controller frequency, core frequency, power segment, internal cache size, and type.
- Mixing microprocessors of different stepping levels within the same server model is supported.
- When mixing microprocessors with different stepping levels within the same server model, you do not have to install the microprocessor with lowest stepping level and features in microprocessor socket 1.
- Both microprocessor voltage regulator modules are integrated on the system board.
- Read the documentation that comes with the microprocessor to determine whether you have to update the server firmware. To download the latest level of server firmware and other code updates for your server, go to <http://www.lenovo.com/support>.
- The microprocessor speeds are automatically set for this server; therefore, you do not have to set any microprocessor frequency-selection jumpers or switches.
- If the thermal-grease protective cover (for example, a plastic cap or tape liner) is removed from the heat sink, do not touch the thermal grease on the bottom of the heat sink or set down the heat sink. For more information about applying or working with thermal grease, see “Thermal grease” on page 279.

**Note:** Removing the heat sink from the microprocessor destroys the even distribution of the thermal grease and requires replacing the thermal grease.

- To order an additional optional microprocessor, contact your sales representative or reseller.

Installation tool has two settings for installing two different sizes of microprocessors. The settings that are marked on the tool are “L” for smaller low core microprocessors, and “H” for larger high core microprocessors.

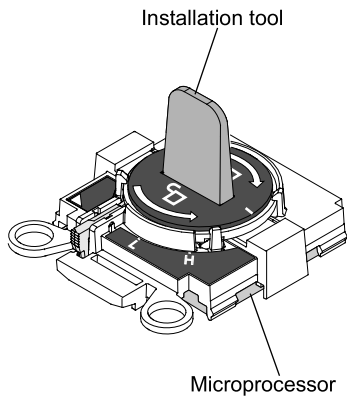

Figure 238. Microprocessor installation tools

To replace a microprocessor and heat sink, complete the following steps:

Step 1. Read the safety information that begins on “Safety” on page v and “Installation guidelines” on page 287.

Step 2. Turn off the server and peripheral devices and disconnect the power cords and all external cables.

**Attention:** When you handle static-sensitive devices, take precautions to avoid damage from static electricity. For details about handling these devices, see “Handling static-sensitive devices” on page 289.

Step 3. Remove the top cover (see “Removing the top cover” on page 144).

Step 4. Remove the air baffle (see “Removing the air baffle” on page 147).

Step 5. If you are replacing microprocessor 1, remove the memory modules from DIMM connectors 6 and 7. If you are replacing microprocessor 2, remove the memory modules from DIMM connectors 18 and 19. See “Removing a memory module” on page 165 for instructions.

Step 6. Rotate the heat sink retention module release lever to the open position.

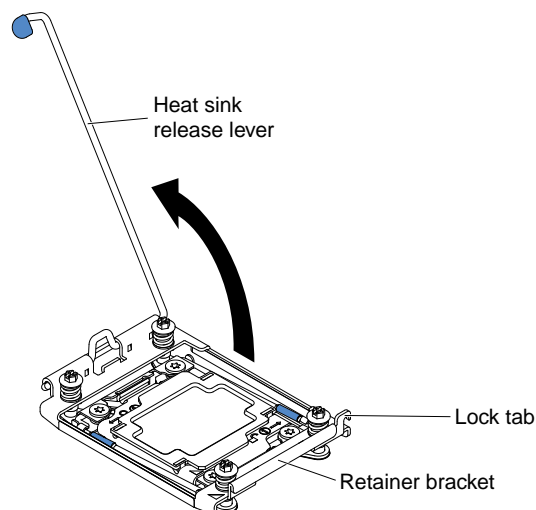

Figure 239. Heat-sink lever rotation

Step 7. Open the microprocessor socket release levers and retainer:

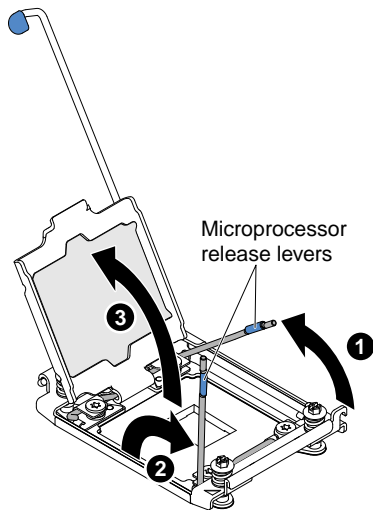

Figure 240. Microprocessor socket levers and retainer disengagement

- a. Identify which release lever is labeled as the first release lever to open and open it.
- b. Open the second release lever on the microprocessor socket.
- c. Open the microprocessor retainer.

**Attention:** Do not touch the connectors on the microprocessor and the microprocessor socket.

Step 8. Install the microprocessor on the microprocessor socket:

- a. Touch the static-protective package that contains the new microprocessor to any *unpainted* on the chassis or any *unpainted* metal surface on any other grounded rack component; then, carefully remove the microprocessor from the package.

**Note:** Do not touch the microprocessor contacts. Contaminants on the microprocessor contacts, such as oil from your skin, can cause connection failures between the contacts and the socket.

- b. Align the installation tool with the microprocessor socket and lower down the installation tool. The installation tool rests flush on the socket only if properly aligned.

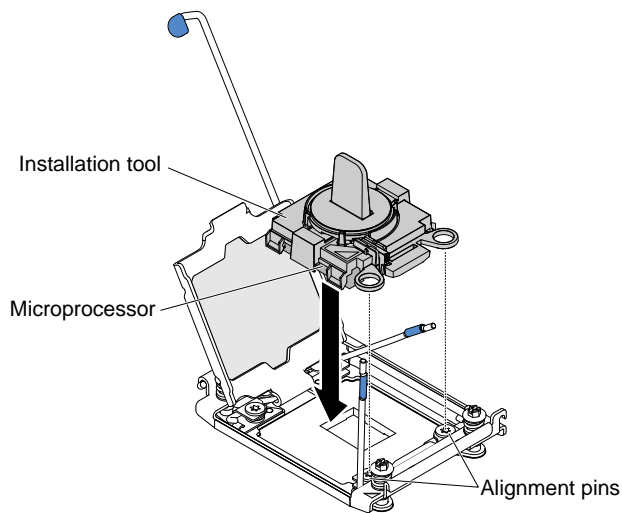

Figure 241. Installation tool alignment

- c. Install the microprocessor using the following instructions for your installation tool.
- Twist the handle of the installation tool assembly counterclockwise to the unlocked position until you can not twist the handle any further; then, lift the installation tool out of the socket.

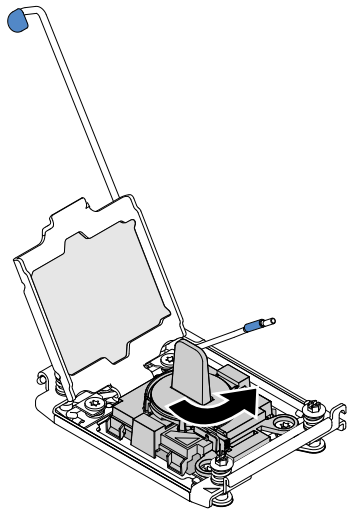

Figure 242. Installation tool handle adjustment

The following illustrations show the installation tool in the locked and unlocked positions.

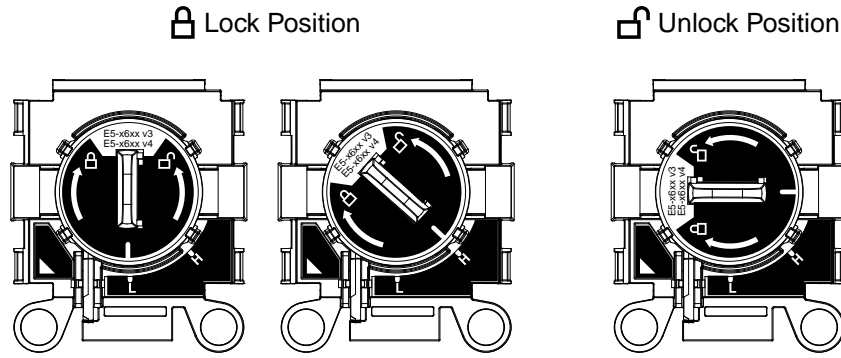

Figure 243. Installation tool

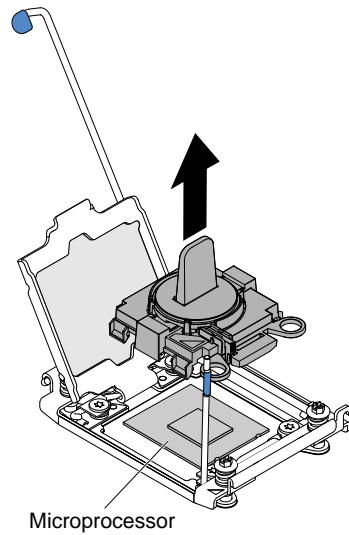

Figure 244. Installation tool removal

**Attention:**

- Do not press the microprocessor into the socket.
- Make sure that the microprocessor is oriented and aligned correctly in the socket before you try to close the microprocessor retainer.
- Do not touch the thermal material on the bottom of the heat sink or on top of the microprocessor. Touching the thermal material will contaminate it.

Step 9. Remove the cover from the retainer bracket, if one is present. Store the cover in a safe place.

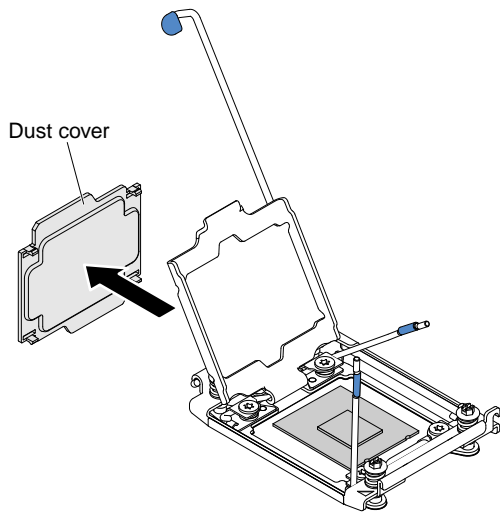

Figure 245. Socket cover removal

**Attention:** When you handle static-sensitive devices, take precautions to avoid damage from static electricity. For details about handling these devices, see “Handling static-sensitive devices” on page 289.

Step 10. Close the microprocessor socket release levers and retainer:

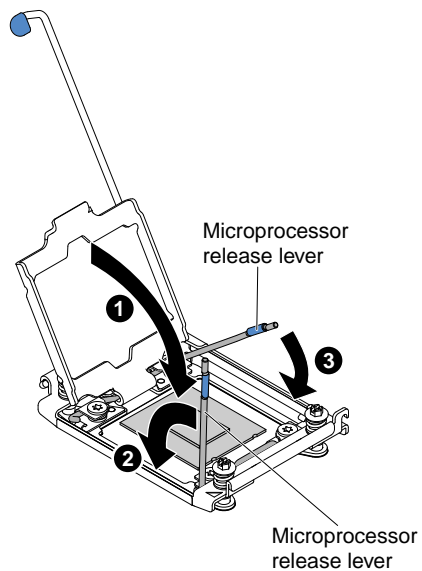

Figure 246. Microprocessor socket levers and retainer engagement

- a. Close the microprocessor retainer on the microprocessor socket.
- b. Identify which release lever is labeled as the first release lever to close and close it.
- c. Close the second release lever on the microprocessor socket.

Step 11. Install the heat sink.

**Attention:**

- Do not set down the heat sink after you remove the plastic cover.



- Do not touch the thermal grease on the bottom of the heat sink after you remove the plastic cover. Touching the thermal grease will contaminate it. See “Thermal grease” on page 279 for more information.

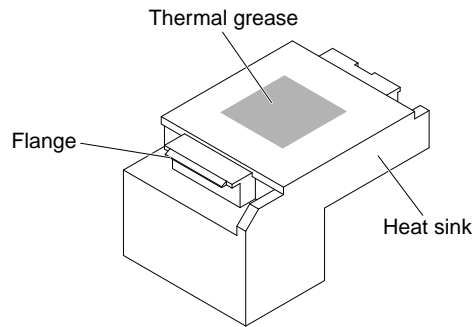

*Figure 247. Thermal grease*

- a. Remove the plastic protective cover from the bottom of the heat sink.
- b. Grasp the heat sink firmly as the following illustration to avoid possible damage to the heat sink.

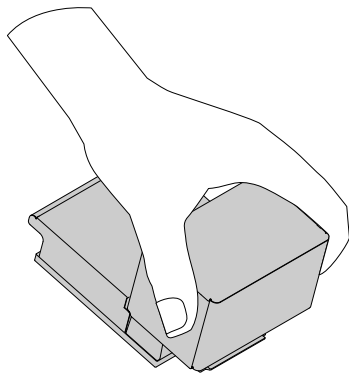

*Figure 248. Heat sink*

- c. Position the heat sink over the microprocessor. The heat sink is keyed to assist with proper alignment.

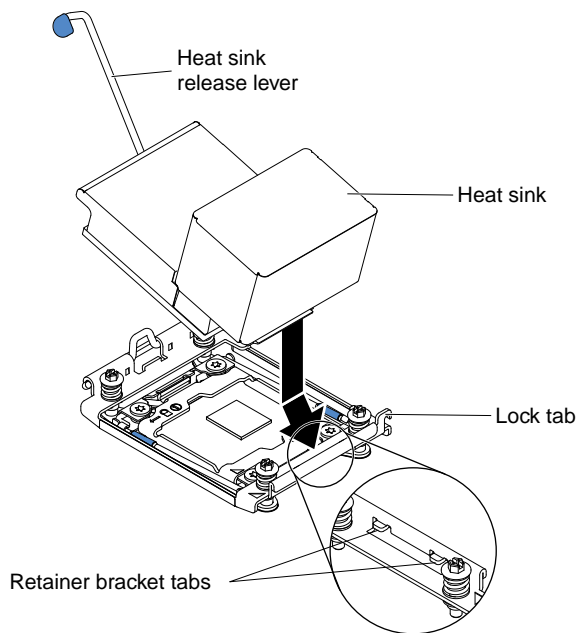

Figure 249. Heat sink installation

- d. Align and insert the front tab of the heat sink under the retainer bracket tabs.
- e. Align and place the heat sink on top of the microprocessor in the retention bracket, thermal material side down.
- f. Press firmly on the heat sink.
- g. Rotate the heat sink retention module release lever to the closed position and hook it underneath the lock tab.

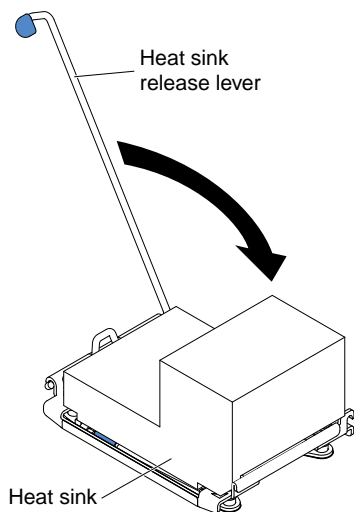

Figure 250. Heat sink retention module release lever

- Step 12. Reinstall the air baffle (see “Replacing the air baffle” on page 148).
- Step 13. Install the top cover (see “Replacing the top cover” on page 146).
- Step 14. Slide the server into the rack.
- Step 15. Reconnect the power cords and any cables that you removed.

Step 16. Turn on the peripheral devices and the server.

## Thermal grease

The thermal grease must be replaced whenever the heat sink has been removed from the top of the microprocessor and is going to be reused or when debris is found in the grease. Use this information to replace damaged or contaminated thermal grease on the microprocessor and heat sink.

When you are installing the heat sink on the same microprocessor that it was removed from, make sure that the following requirements are met:

- The thermal grease on the heat sink and microprocessor is not contaminated.
- Additional thermal grease is not added to the existing thermal grease on the heat sink and microprocessor.

### Notes:

- Read the safety information that begins on “Safety” on page v.
- Read the “Installation guidelines” on page 287.
- Read “Handling static-sensitive devices” on page 289.

To replace damaged or contaminated thermal grease on the microprocessor and heat sink, complete the following steps:

Step 1. Place the heat sink on a clean work surface.

Step 2. Remove the cleaning pad from its package and unfold it completely.

Step 3. Use the cleaning pad to wipe the thermal grease from the bottom of the heat sink.

**Note:** Make sure that all of the thermal grease is removed.

Step 4. Use a clean area of the cleaning pad to wipe the thermal grease from the microprocessor; then, dispose of the cleaning pad after all of the thermal grease is removed.

Step 5. Use the thermal-grease syringe to place 9 uniformly spaced dots of 0.02 mL each on the top of the microprocessor. The outermost dots must be within approximately 5 mm of the edge of the microprocessor; this is to ensure uniform distribution of the grease.

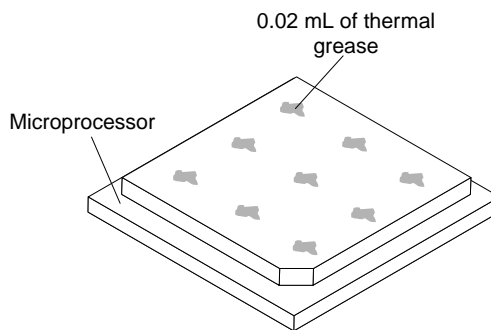

Figure 251. Thermal grease distribution

**Note:** If the grease is properly applied, approximately half of the grease will remain in the syringe.

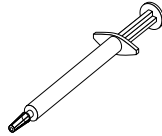

Figure 252. Syringe

Step 6. Install the heat sink onto the microprocessor as described in Step 11 on page 276.

## Removing the heat-sink retention module

Use this information to remove the heat-sink retention module.

To remove a heat-sink retention module, complete the following steps:

- Step 1. Read the safety information that begins on “Safety” on page v and “Installation guidelines” on page 287.
- Step 2. Turn off the server and peripheral devices and disconnect the power cords and all external cables.
- Step 3. Remove the top cover (see “Removing the top cover” on page 144).
- Step 4. Remove the air baffle (see “Removing the air baffle” on page 147).
- Step 5. Remove the heat sink (see “Removing a microprocessor and heat sink” on page 265).

**Attention:** When you remove a microprocessor and heat sink, be sure to keep each heat sink with its microprocessor for reinstallation.

- Step 6. Use a screwdriver and remove the four screws that secure the retention module to the system board; then, lift the retention module from the system board.

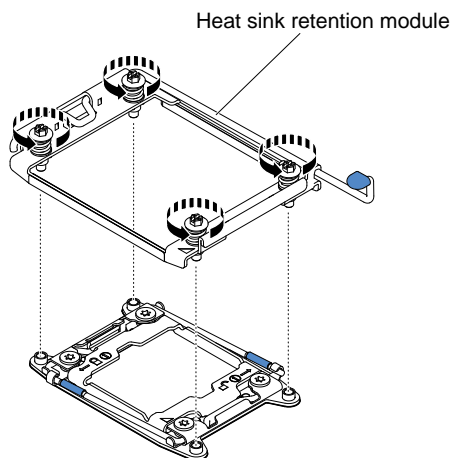

Figure 253. Heat-sink retention module removal

- Step 7. If you are instructed to return the heat-sink retention module, follow all the packaging instructions, and use any packaging materials for shipping that are supplied to you.

## Replacing the heat-sink retention module

Use this information to replace the heat-sink retention module.

To install a heat-sink retention module, complete the following steps:

- Step 1. Read the safety information that begins on “Safety” on page v and “Installation guidelines” on page 287.
- Step 2. Turn off the server and peripheral devices and disconnect the power cords and all external cables.
- Step 3. Remove the top cover (see “Removing the top cover” on page 144).
- Step 4. Remove the air baffle (see “Removing the air baffle” on page 147).
- Step 5. Align the retention module with the holes on the system board.
- Step 6. Use a screwdriver to reinstall the four screws.

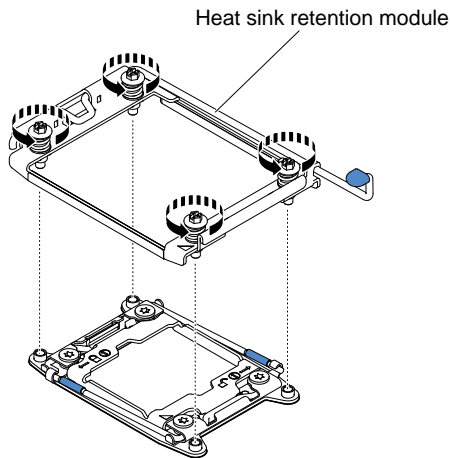

Figure 254. Heat-sink retention module installation

- Step 7. Reinstall the heat sink (see “Replacing a microprocessor and heat sink” on page 270).
 

**Attention:** Make sure that you install each heat sink with its paired microprocessor.
- Step 8. Reinstall the air baffle (see “Replacing the air baffle” on page 148).
- Step 9. Install the top cover (see “Replacing the top cover” on page 146).
- Step 10. Slide the server into the rack.
- Step 11. Reconnect the power cords and any cables that you removed.
- Step 12. Turn on the peripheral devices and the server.

## Removing the system board

Use this information to remove the system board.

### Notes:

1. When you replace the system board, you must either update the server with the latest firmware or restore the pre-existing firmware that the customer provides on a diskette or CD image. Make sure that you have the latest firmware or a copy of the pre-existing firmware before you proceed.
2. When you replace the system board, make sure that you remove the Integrated Management Module Advanced Upgrade and place it on the new system board. For information about the Advanced Upgrade, see “Using the remote presence and blue-screen capture features” on page 53.
3. Before you replace the system board, make sure that you back up any features on demand (FoD) keys that were enabled. Reactivate any Features on Demand features. Instructions for automating the activation of features and installing activation keys is in the *Features on Demand User's Guide*. To download the document, go to <http://www.ibm.com/systems/x/fod/>, log in, and click **Help**.

To remove the system board, complete the following steps:

- Step 1. Read the safety information that begins on “Safety” on page v, “Handling static-sensitive devices” on page 289, and “Installation guidelines” on page 287.
- Step 2. Turn off the server and any attached devices.
- Step 3. Turn off the peripheral devices and disconnect all power cords.

**Note:** When you replace the system board, you must either update the server with the latest firmware or restore the pre-existing firmware that the customer provides on a diskette or CD image. Make sure that you have the latest firmware or a copy of the pre-existing firmware before you proceed.

- Step 4. Pull the power supplies out of the rear of the server, just enough to disengage them from the server.
- Step 5. Remove the top cover (see “Removing the top cover” on page 144).
- Step 6. Remove all PCI riser-card assemblies and adapters (see “Removing a riser-card assembly” on page 180 and “Removing an adapter” on page 185).
- Step 7. Remove the air baffle (see “Removing the air baffle” on page 147).
- Step 8. Remove the fan cage assembly (See “Removing the fan cage assembly” on page 172).
- Step 9. Remove any backplate assembly or any backplane (See “Removing the 2.5-inch simple-swap backplate assembly/hot-swap hard disk drive backplane” on page 241 and “Removing the 3.5-inch simple-swap backplate assembly/hot-swap hard disk drive backplane” on page 243).
- Step 10. Remove the dedicate slotless RAID controller (see “Removing the dedicated slotless RAID controller” on page 183).
- Step 11. Remove the paddle card module (see “Removing the power paddle module” on page 149).
- Step 12. Remove the memory modules and set them aside on a static-protective surface for reinstallation (see “Removing a memory module” on page 165).



**Note:** Make a note of the location of each DIMM as you remove it, so that you can later reinstall it in the same connector.

- Step 13. (Trained technician only) Remove all heat sinks and microprocessors, and set them aside on a static-protective surface for reinstallation (see “Removing a microprocessor and heat sink” on page 265).

**Note:** Do not allow the thermal grease to come in contact with anything, and keep each heat sink paired with its microprocessor for reinstallation. Contact with any surface can compromise the thermal grease and the microprocessor socket. A mismatch between the microprocessor and its original heat sink can require the installation of a new heat sink.

- Step 14. Disconnect all cables from the system board. Make a list of each cable as you disconnect it; you can then use this as a checklist when you install the new system board (see “Internal cable routing and connectors” on page 131 for more information).

**Attention:** Disengage all latches, release tabs or locks on cable connectors when you disconnect all cables from the system board. Failing to release them before removing the cables will damage the cable sockets on the system board. The cable sockets on the system board are fragile. Any damage to the cable sockets may require replacing the system board.

- Step 15.  Loosen the two thumbscrews (located near the front of the server) that secure the system board to the server and  slide the system board toward the front of the server.
- Step 16. Grasp both system-board handles and lift up the left side of the system board slightly and carefully remove it from the chassis, being careful not to damage any surrounding components.

**Note:** Use the system-board handles to lift the system board only. Do not attempt to lift the server using the system board handles.

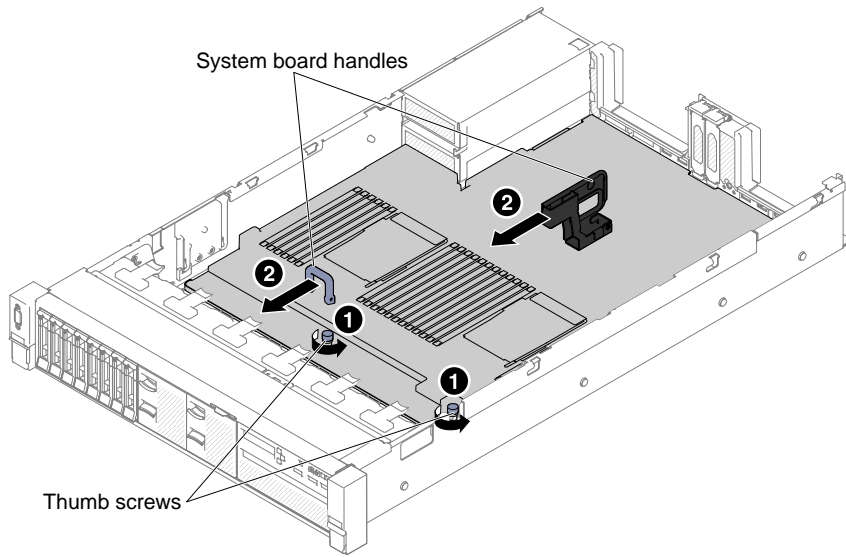

Figure 255. System board removal

Step 17. **1** Push the system board toward the broadside of the server and **2** lift the system board up.

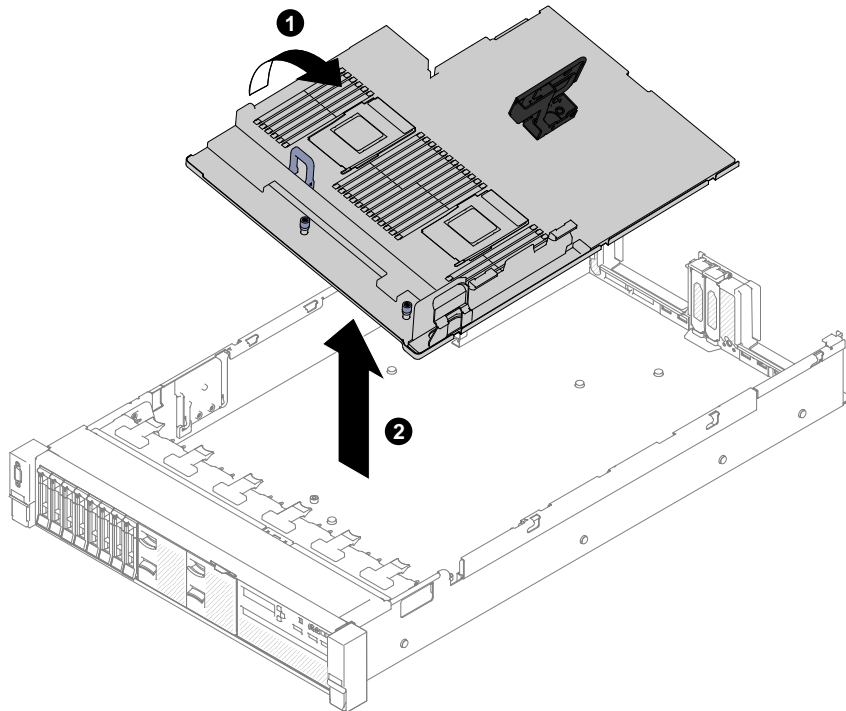

Figure 256. System board removal

Step 18. If you are instructed to return the system board, follow all packaging instructions, and use any packaging materials for shipping that are supplied to you.

**Attention:** Make sure to place the socket covers for the microprocessor sockets on the system board before returning the system board.

## Replacing the system board

Use this information to replace the system board.

### Notes:

1. When you reassemble the components in the server, be sure to route all cables carefully so that they are not exposed to excessive pressure.
2. When you replace the system board, you must either update the server with the latest firmware or restore the pre-existing firmware from a diskette or CD image. Make sure that you have the latest firmware or a copy of the pre-existing firmware before you proceed. See “Updating the firmware” on page 43, “Updating the Universal Unique Identifier (UUID)” on page 57, and “Updating the DMI/SMBIOS data” on page 59 for more information.
3. When you replace the system board, make sure that you remove the Integrated Management Module Advanced Upgrade and place it on the new system board. For information about the Advanced Upgrade, see “Using the remote presence and blue-screen capture features” on page 53.
4. Reactivate any Features on Demand features. Instructions for automating the activation of features and installing activation keys is in the *Features on Demand User's Guide*. To download the document, go to <http://www.ibm.com/systems/x/fod/>, log in, and click **Help**.

**Important:** Some cluster solutions require specific code levels or coordinated code updates. If the device is part of a cluster solution, verify that the latest level of code is supported for the cluster solution before you update the code.

To install the system board, complete the following steps:

- Step 1. Read the safety information that begins on “Safety” on page v, “Handling static-sensitive devices” on page 289, and “Installation guidelines” on page 287.
- Step 2. Align the system board with the slots on the side of the chassis and lower the right side into the chassis first; then, lower the other side of the system board into the chassis.



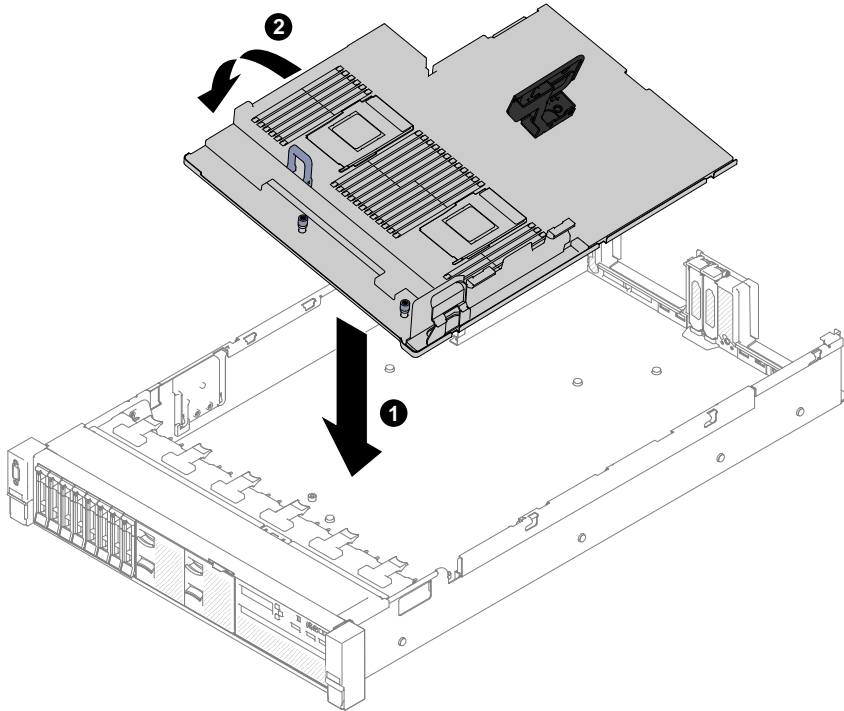

Figure 257. System board installation

- Step 3. **1** Slide the system-board toward the rear of the server to secure it in place.
- Step 4. **2** Tighten the two thumbscrews to secure the system board to the chassis.

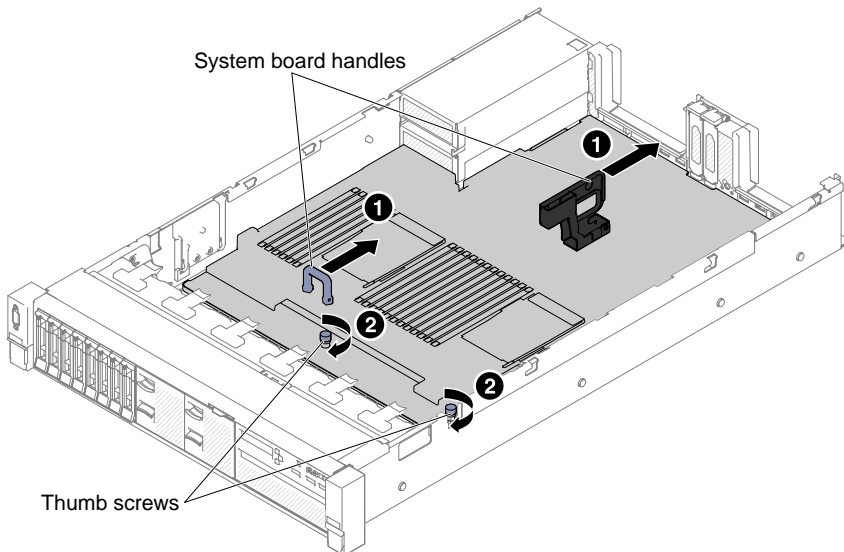

Figure 258. System board installation

- Step 5. Reconnect to the system board the cables that you disconnected in step 13 of “Removing the system board” on page 281 (see “Internal cable routing and connectors” on page 131).
- Step 6. (Trained technician only) Install the microprocessor and heat sink (see “Replacing a microprocessor and heat sink” on page 270).
- Step 7. Install the memory modules (see “Installing a memory module” on page 165).

- Step 8. If necessary, install the virtual media key.
- Step 9. Install the coin-cell battery (see “Replacing the coin-cell battery (also called CMOS battery)” on page 250).
- Step 10. Install the PCI riser-card assemblies and adapters, if any were installed (see “Replacing an adapter” on page 189 and “Replacing a riser-card assembly” on page 181).
- Step 11. Install the air baffle (see “Replacing the air baffle” on page 148).
- Step 12. Install the fan cage assembly (see “Replacing the fan cage assembly” on page 173).
- Step 13. Install the top cover (see “Replacing the top cover” on page 146).
- Step 14. Push the power supplies back into the server.
- Step 15. Slide the server into the rack.
- Step 16. Reconnect the power cords and any cables that you removed.
- Step 17. Turn on the peripheral devices and the server.
- Step 18. Start the Setup Utility and reset the configuration.
- Set the system date and time.
  - Set the power-on password.
  - Reconfigure the server.
- See “Using the Setup Utility” on page 47 for more details.
- Step 19. Either update the server with the latest RAID firmware or restore the pre-existing firmware from a diskette or CD image.
- Step 20. Update the UUID (see “Updating the Universal Unique Identifier (UUID)” on page 57).
- Step 21. Update the DMI/SMBIOS (see “Updating the DMI/SMBIOS data” on page 59).
- Step 22. Reactivate any Features on Demand features.

---

## Installing optional devices

This section provides detailed instructions for installing optional hardware devices in the server.

In addition to the instructions in this chapter for installing optional hardware devices, updating the firmware and device drivers, and completing the installation, Business Partners must also complete the steps in “Instructions for Business Partners” on page 311.

**Important:** To help ensure that the devices that you install work correctly and do not introduce problems, observe the following precautions:

1. Make sure that the server and the installed firmware levels support the devices that you are installing. If necessary, update the UEFI and IMM firmware and any other firmware that is stored on the system board. For information about where firmware is stored in the server, see “Updating the firmware” on page 43. For a list of supported optional devices for the server, see <http://www.lenovo.com/serverproven/>.
2. Use the best practices to apply current firmware and device-driver updates for the server and optional devices. To download the “System x Firmware Update Best Practices” document, go to [www.ibm.com/support/entry/portal/docdisplay?Indocid=MIGR-5082923&brandind=5000008](http://www.ibm.com/support/entry/portal/docdisplay?Indocid=MIGR-5082923&brandind=5000008). Additional hints and tips are available from the following sites:
  - Support website: <http://www.lenovo.com/support>
  - System x configuration tools: [http://shop.lenovo.com/us/en/systems/server-library/#comboFilters\[category\]=.Tools](http://shop.lenovo.com/us/en/systems/server-library/#comboFilters[category]=.Tools)

3. Before you install optional hardware devices, make sure that the server is working correctly. Start the server and make sure that the operating system starts, if an operating system is installed, or that a 19990305 error code is displayed, indicating that an operating system was not found but the server is otherwise working correctly. If the server is not working correctly, see “Running the DSA Preboot diagnostic programs” on page 76 for information about how to run diagnostics.
4. Follow the installation procedures in this chapter and use the correct tools. Incorrectly installed devices can cause system failure because of damaged pins in sockets or connectors, loose cabling, or loose components.

## Installation guidelines

Use the installation guidelines to install the Lenovo Storage DX8200.

**Attention:** Static electricity that is released to internal server components when the server is powered-on might cause the system to halt, which might result in the loss of data. To avoid this potential problem, always use an electrostatic-discharge wrist strap or other grounding system when removing or installing a hot-swap device.

Before you install optional devices, read the following information:

- Read the safety information in “Safety” on page v, the guidelines in “Working inside the server with the power on” on page 288, and “Handling static-sensitive devices” on page 289. This information will help you work safely.
- Make sure that the devices that you are installing are supported. For a list of supported optional devices for the server, see <http://www.lenovo.com/serverproven/>.
- When you install your new server, take the opportunity to download and apply the most recent firmware updates. This step will help to ensure that any known issues are addressed and that your server is ready to function at maximum levels of performance. To download firmware updates for your server, go to <http://www.ibm.com/support/fixcentral>.

**Important:** Some cluster solutions require specific code levels or coordinated code updates. If the device is part of a cluster solution, verify that the latest level of code is supported for the cluster solution before you update the code.

For additional information about tools for updating, managing, and deploying firmware, see the ToolsCenter for System x and BladeCenter at <http://publib.boulder.ibm.com/infocenter/toolsctr/v1r0/>.

- Before you install optional hardware, make sure that the server is working correctly. Start the server, and make sure that the operating system starts, if an operating system is installed, or that a 19990305 error code is displayed, indicating that an operating system was not found but the server is otherwise working correctly. If the server is not working correctly, see “Running the DSA Preboot diagnostic programs” on page 76 for information about how to run diagnostics.
- Observe good housekeeping in the area where you are working. Place removed covers and other parts in a safe place.
- Do not attempt to lift an object that you think is too heavy for you. If you have to lift a heavy object, observe the following precautions:
  - Make sure that you can stand safely without slipping.
  - Distribute the weight of the object equally between your feet.
  - Use a slow lifting force. Never move suddenly or twist when you lift a heavy object.
  - To avoid straining the muscles in your back, lift by standing or by pushing up with your leg muscles.
- Make sure that you have an adequate number of properly grounded electrical outlets for the server, monitor, and other devices.
- Back up all important data before you make changes to disk drives.

- Have a small flat-blade screwdriver, a small Phillips screwdriver, and a T8 torx screwdriver available.
- To view the error LEDs on the system board and internal components, leave the server connected to power.
- You do not have to turn off the server to install or replace hot-swap power supplies, hot-swap fans, or hot-plug USB devices. However, you must turn off the server before you perform any steps that involve removing or installing adapter cables and you must disconnect the power source from the server before you perform any steps that involve removing or installing a riser card.
- Blue on a component indicates touch points, where you can grip the component to remove it from or install it in the server, open or close a latch, and so on.
- Orange on a component or an orange label on or near a component indicates that the component can be hot-swapped, which means that if the server and operating system support hot-swap capability, you can remove or install the component while the server is running. (Orange can also indicate touch points on hot-swap components.) See the instructions for removing or installing a specific hot-swap component for any additional procedures that you might have to perform before you remove or install the component.
- When you are finished working on the server, reinstall all safety shields, guards, labels, and ground wires.

### **System reliability guidelines**

The system reliability guidelines to ensure proper system cooling.

To help ensure proper system cooling and system reliability, make sure that the following requirements are met:

- Each of the drive bays has a drive or a filler panel and electromagnetic compatibility (EMC) shield installed in it.
- Each of the power-supply bays has a power supply or a filler installed in it.
- If the server has redundant power, each of the power-supply bays has a power supply installed in it.
- There is adequate space around the server to allow the server cooling system to work properly. Leave approximately 50 mm (2.0 in.) of open space around the front and rear of the server. Do not place objects in front of the fans. For proper cooling and airflow, replace the server cover before you turn on the server. Operating the server for extended periods of time (more than 30 minutes) with the server cover removed might damage server components.
- You have followed the cabling instructions that come with optional adapters.
- You have replaced a failed fan within 48 hours.
- You have replaced a hot-swap fan within 30 seconds of removal.
- You have replaced a hot-swap drive within 2 minutes of removal.
- You have replaced a failed hot-swap power supply within 2 minutes of removal.
- You do not operate the server without the air baffle installed. Operating the server without the air baffle might cause the microprocessor to overheat.
- Microprocessor socket 2 always contains either a socket cover or a microprocessor and heat sink.
- You have installed the fifth and sixth fans when you installed the second microprocessor option.

### **Working inside the server with the power on**

Guidelines to work inside the server with the power on.

**Attention:** Static electricity that is released to internal server components when the server is powered-on might cause the server to halt, which might result in the loss of data. To avoid this potential problem, always use an electrostatic-discharge wrist strap or other grounding system when you work inside the server with the power on.

You might have to have the server turned on while the cover is off, to look at LCD system information display panel or replace hot swap components. Follow these guidelines when you work inside a server that is turned on:

- Avoid wearing loose-fitting clothing on your forearms. Button long-sleeved shirts before working inside the server; do not wear cuff links while you are working inside the server.
- Do not allow your necktie or scarf to hang inside the server.
- Remove jewelry, such as bracelets, necklaces, rings, and loose-fitting wrist watches.
- Remove items from your shirt pocket, such as pens and pencils, that could fall into the server as you lean over it.
- Avoid dropping any metallic objects, such as paper clips, hairpins, and screws, into the server.

## Handling static-sensitive devices

Use this information to handle static-sensitive devices.

**Attention:** Static electricity can damage the server and other electronic devices. To avoid damage, keep static-sensitive devices in their static-protective packages until you are ready to install them.

To reduce the possibility of damage from electrostatic discharge, observe the following precautions:

- Limit your movement. Movement can cause static electricity to build up around you.
- The use of a grounding system is recommended. For example, wear an electrostatic-discharge wrist strap, if one is available. Always use an electrostatic-discharge wrist strap or other grounding system when working inside the server with the power on.
- Handle the device carefully, holding it by its edges or its frame.
- Do not touch solder joints, pins, or exposed circuitry.
- Do not leave the device where others can handle and damage it.
- While the device is still in its static-protective package, touch it to an unpainted metal surface on the outside of the server for at least 2 seconds. This drains static electricity from the package and from your body.
- Remove the device from its package and install it directly into the server without setting down the device. If it is necessary to set down the device, put it back into its static-protective package. Do not place the device on the server cover or on a metal surface.
- Take additional care when handling devices during cold weather. Heating reduces indoor humidity and increases static electricity.

## Installing a 8x 2.5-inch simple-swap HDD ServeRAID assembly kit

Use this information to install a 8x 2.5-inch simple-swap HDD ServeRAID assembly kit.

You can install a Lenovo Storage DX8200 8x 2.5-inch simple-swap HDD ServeRAID assembly kit to support eight 2.5-inch simple-swap hard disk drives in the server. See <http://www.lenovo.com/serverproven/> for a list of supported optional devices. To order a 8x 2.5-inch hot-swap HDD assembly kit, contact your sales representative or reseller.

The 8x 2.5-inch simple-swap HDD ServeRAID assembly kit contains one simple-swap backplate assembly.

To install a 8x 2.5-inch hot-swap HDD assembly kit, complete the following steps:

- Step 1. Read the safety information that begins on “Safety” on page v and “Installation guidelines” on page 287.

- Step 2. Turn off the server and peripheral devices and disconnect the power cords and all external cables, if necessary.
- Step 3. Remove the top cover (see “Removing the top cover” on page 144).
- Step 4. Remove the two 4-drive filler panels.
- Step 5. Pull the hard disk drives or fillers out of the server slightly to disengage them from the backplates. For more information, (see “Removing a simple-swap hard disk drive” on page 156).
- Step 6. To obtain more working room, remove the fan cage assembly (see “Removing the fan cage assembly” on page 172).
- Step 7. Insert the backplate assembly tabs into slots on the bottom of the cage and push the backplate assembly forward into the release latch (on top of the backplate assembly cage) until the backplate assembly is locked in place.

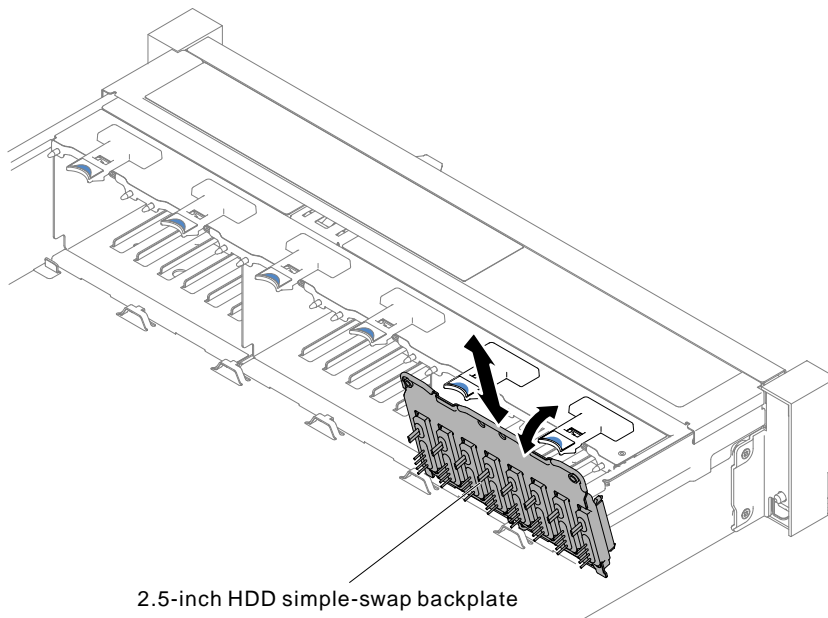

*Figure 259. 2.5-inch simple-swap/hot-swap hard disk drive backplate assembly/backplane installation*

- Step 8. Connect the SAS signal and power/configuration cables to the system board.

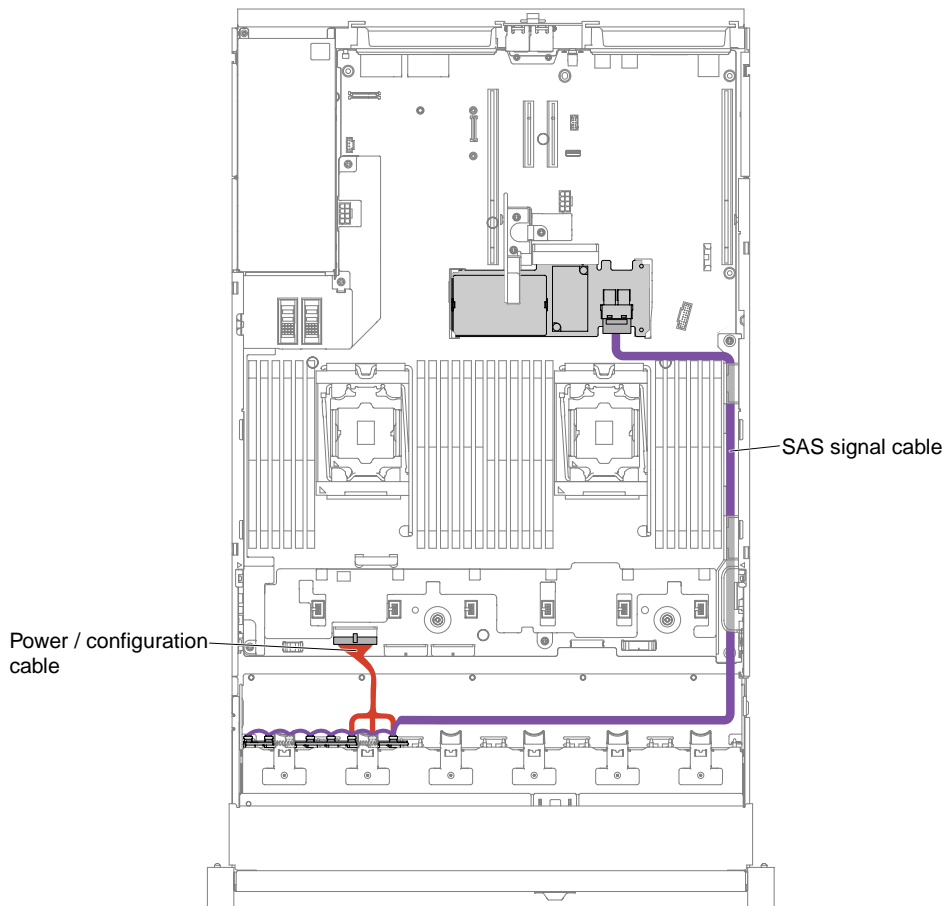

Figure 260. 8x2.5-inch simple-swap hard disk drive with hardware RAID cabling

- Step 9. Replace the fan cage assembly and fans if you removed them (see “Replacing the fan cage assembly” on page 173 and “Replacing a hot-swap fan” on page 175).
- Step 10. Reinstall the hard disk drives (see “Replacing a hot-swap hard disk drive” on page 154).
- Step 11. Install the top cover (see “Replacing the top cover” on page 146).
- Step 12. Slide the server into the rack.
- Step 13. Reconnect the power cords and any cables that you removed.
- Step 14. Turn on the peripheral devices and the server.

## Installing a 8x 3.5-inch simple-swap HDD ServeRAID assembly kit

Use this information to install a 8x 3.5-inch simple-swap HDD ServeRAID assembly kit.

You can install a Lenovo Storage DX8200 8x 3.5-inch simple-swap HDD ServeRAID assembly kit to support eight 3.5-inch simple-swap hard disk drive model in the server. See <http://www.lenovo.com/serverproven/> for a list of supported optional devices. To order a 8x 3.5-inch hot-swap HDD assembly kit, contact your sales representative or reseller.

The 8x 3.5-inch simple-swap HDD ServeRAID assembly kit contains one simple-swap backplate assembly with two cables attached.

To install a 8x 3.5-inch hot-swap HDD assembly kit, complete the following steps:

- Step 1. Read the safety information that begins on “Safety” on page v and “Installation guidelines” on page 287.
- Step 2. Turn off the server and peripheral devices and disconnect the power cords and all external cables, if necessary.
- Step 3. Remove the cover (see “Removing the top cover” on page 144).
- Step 4. Pull the hard disk drives or fillers out of the server slightly to disengage them from the backplates. For more information, see “Removing a simple-swap hard disk drive” on page 156).
- Step 5. To obtain more working room, remove the fan cage (see “Removing the fan cage assembly” on page 172).
- Step 6. Remove the 3.5-inch backplate assembly/backplane. See “Removing the 3.5-inch simple-swap backplate assembly/hot-swap hard disk drive backplane” on page 243
- Step 7. **1** Insert the backplate assembly/backplane tabs into slots on the bottom of the drive cage at an angle; then, rotate the backplate assembly/backplane toward the front the server
- Step 8. **2** Pull the two plungers while you **3** push the backplate assembly to the left to engage the assembly into place.

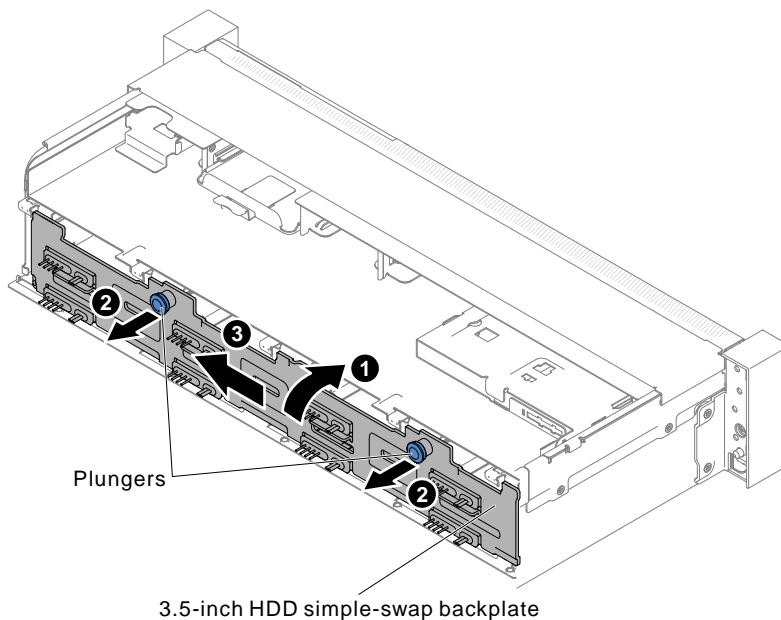

Figure 261. 3.5-inch simple-swap backplate assembly/hot-swap hard disk drive backplane

- Step 9. Connect the SAS signal and power/configuration cables to the system board.



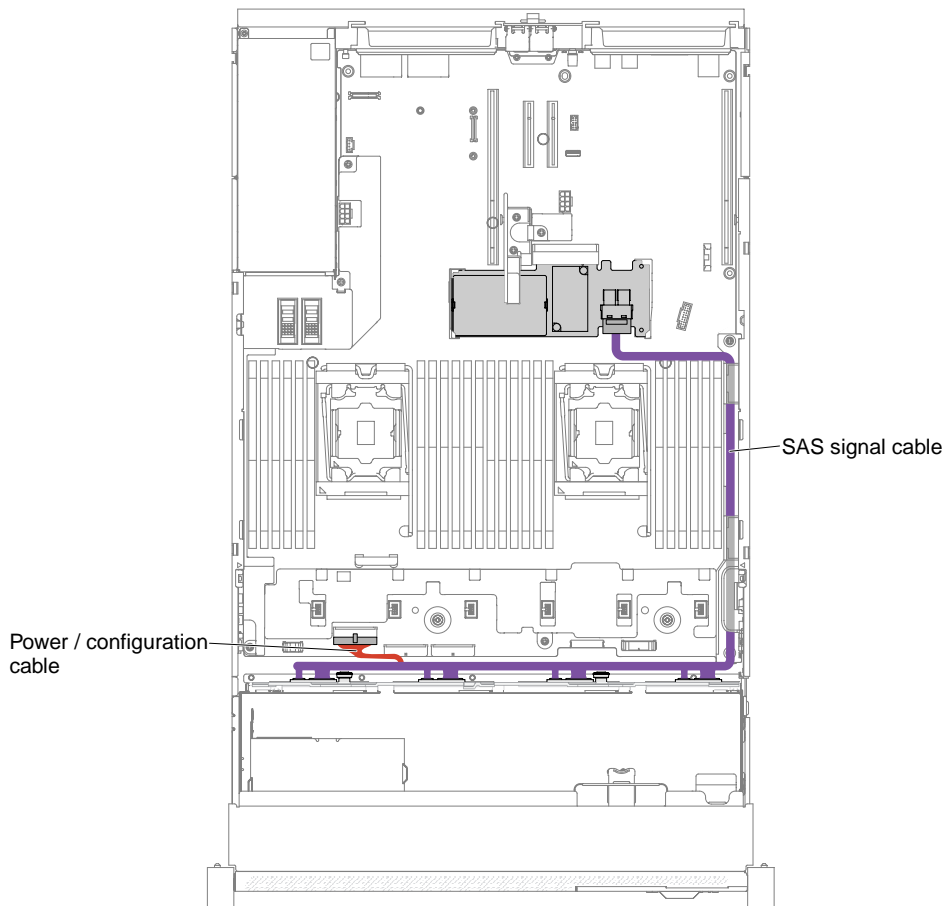

Figure 262. 8x3.5-inch simple-swap hard disk drive with hardware RAID cabling

- Step 10. Replace the fan cage and fans if you removed them (see “Replacing the fan cage assembly” on page 173 and “Replacing a hot-swap fan” on page 175).
- Step 11. Reinstall the hard disk drives (see “Replacing a hot-swap hard disk drive” on page 154).
- Step 12. Install the top cover (see “Replacing the top cover” on page 146).
- Step 13. Slide the server into the rack.
- Step 14. Reconnect the power cords and any cables that you removed.
- Step 15. Turn on the peripheral devices and the server.

## Installing a 8x 2.5-inch hot-swap HDD assembly kit

Use this information to install a 8x 2.5-inch hot-swap HDD assembly kit.

You can install a Lenovo Storage DX8200 8x 2.5-inch hot-swap HDD assembly kit to add eight additional 2.5-inch hot-swap hard disk drives in the server. See <http://www.lenovo.com/serverproven/> for a list of supported optional devices. To order a 8x 2.5-inch hot-swap HDD assembly kit, contact your sales representative or reseller.

The 8x 2.5-inch hot-swap HDD assembly kit contains the following components:

- Eight 2.5-inch HDD fillers
- One hot-swap backplane
- One power/configuration cable (150 mm)

- One power/configuration cable (230 mm)
- One Mini-SAS HD Y-cable (right angle, 905/950 mm)
- One Mini-SAS HD Y-cable (580/590 mm)

**Notes:**

1. The 8x 2.5-inch hot-swap HDD assembly kit including structural parts and Tier 1 parts.
2. You will not use all cables that come with the option kit, some cables may be redundant depending on your configuration.

To install a 8x 2.5-inch hot-swap HDD assembly kit, complete the following steps:

- Step 1. Read the safety information that begins on “Safety” on page v and “Installation guidelines” on page 287.
- Step 2. Turn off the server and peripheral devices and disconnect the power cords and all external cables, if necessary.
- Step 3. Remove the top cover (see “Removing the top cover” on page 144).
- Step 4. Remove the two 4-drive filler panels.

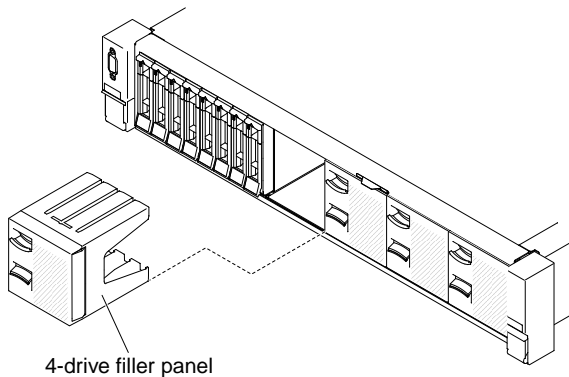

Figure 263. Filler panels

- Step 5. To obtain more working room, remove the fan cage (see “Removing the fan cage assembly” on page 172).
- Step 6. Pull the hard disk drives or fillers out of the server slightly to disengage them from the backplanes. For more information, (see “Removing a hot-swap hard disk drive” on page 153).
- Step 7. Install the new backplane in slot 2 or slot 3 depending on your configuration. Insert the backplane tabs into slots on the bottom of the cage and push the backplane forward into the release latch (on top of the backplane cage) until the backplane is locked in place.

**Note:** You can connect the cables to the drive backplane before installing the backplane onto the cage or you can connect the cables after you install the backplane, if that is easier for you.

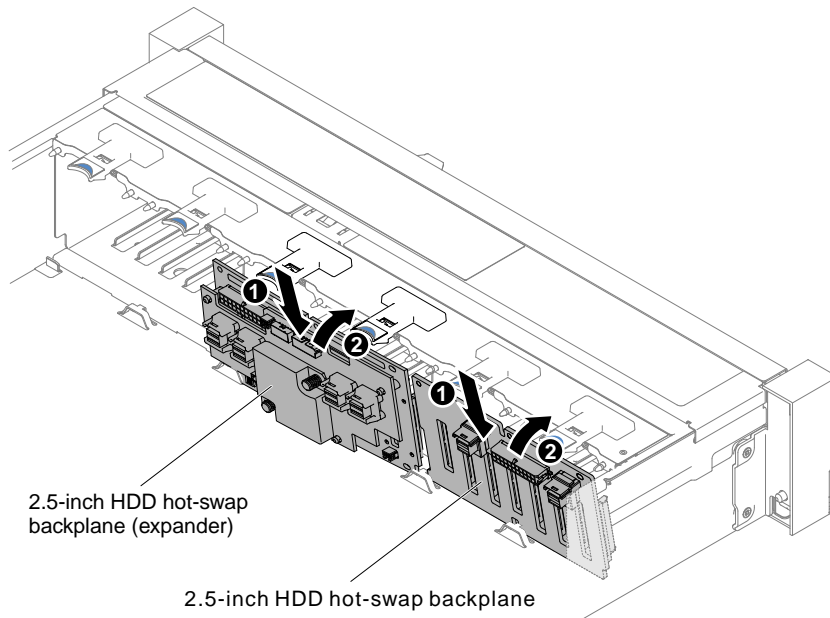

Figure 264. Backplane installation

Step 8. Connect SAS signal and power/configuration cables to the backplane and the system board as the following illustrations.

- If the new backplane is installed in slot 2, route cables as the following illustration.

**Note:** Use right angle Mini-SAS HD Y-cable to connect to PCI expansion slots 4.

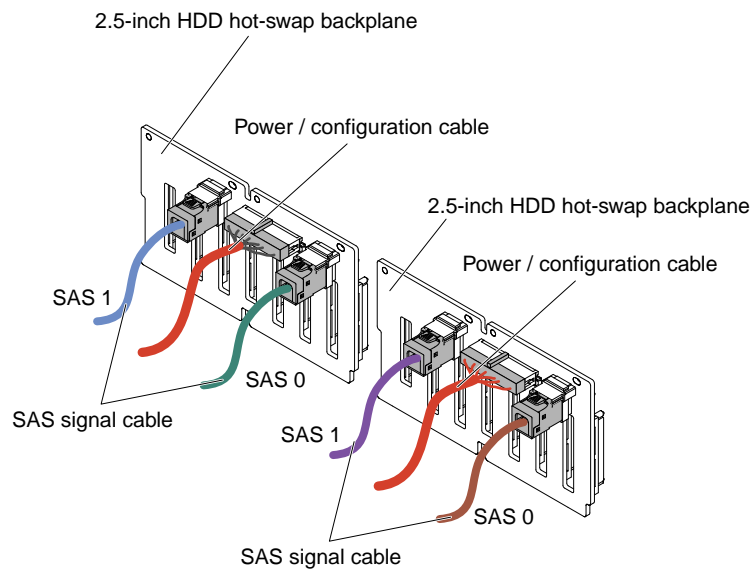

Figure 265. Cable connections

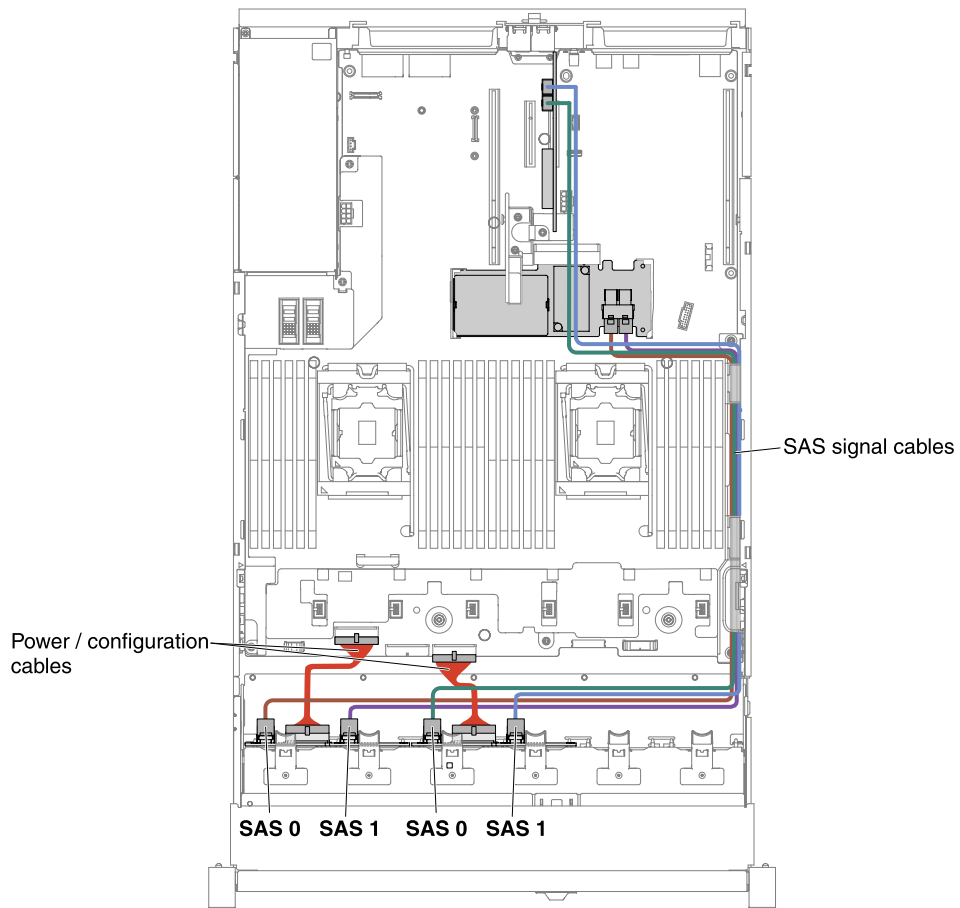

Figure 266. Cable routing

- If the new backplane is installed in slot 3, route cables as following illustrations.
  1. If the backplane is installed in slot 2, route cables as the following illustration.

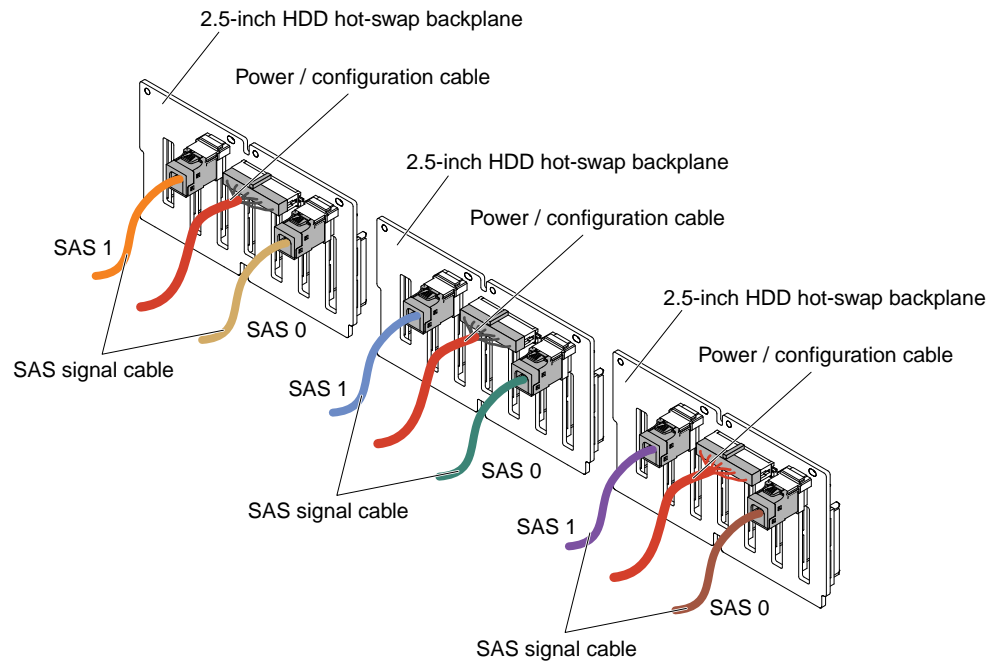

Figure 267. Cable connections

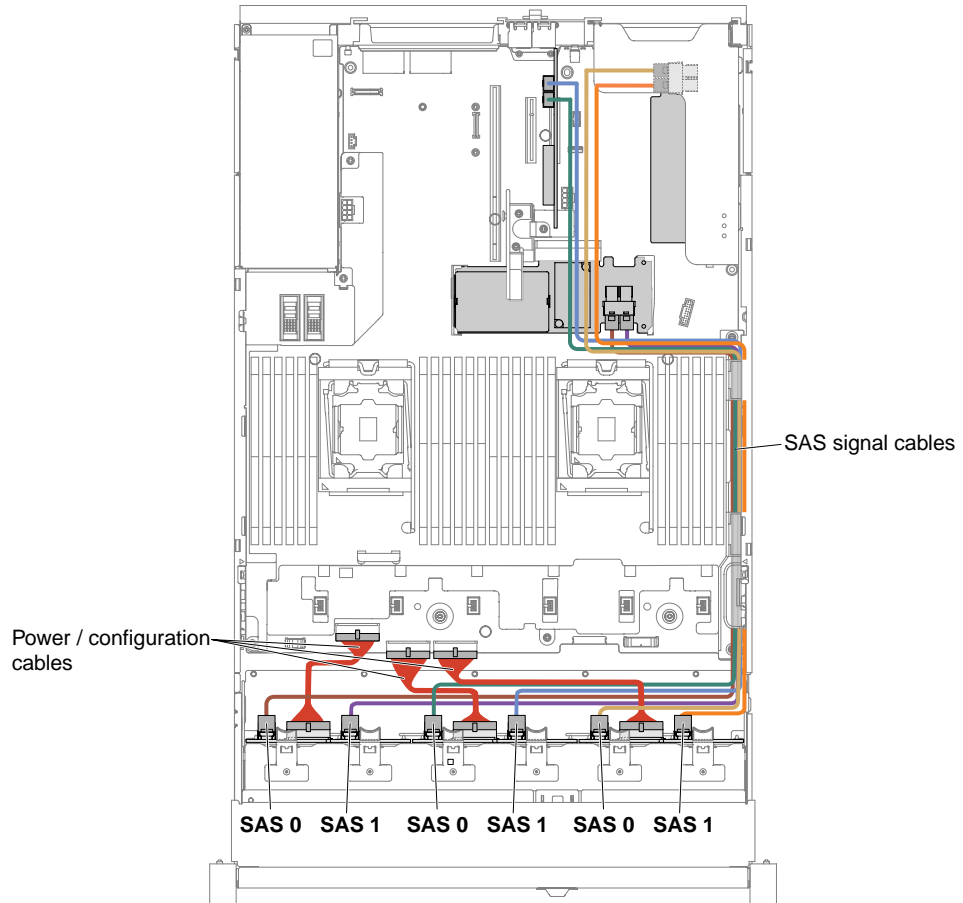

Figure 268. Cable routing

2. If the expander is installed in slot 2, route cables as the following illustration.

**Note:** Use right angle Mini-SAS HD Y-cable to connect to PCI expansion slots 4.

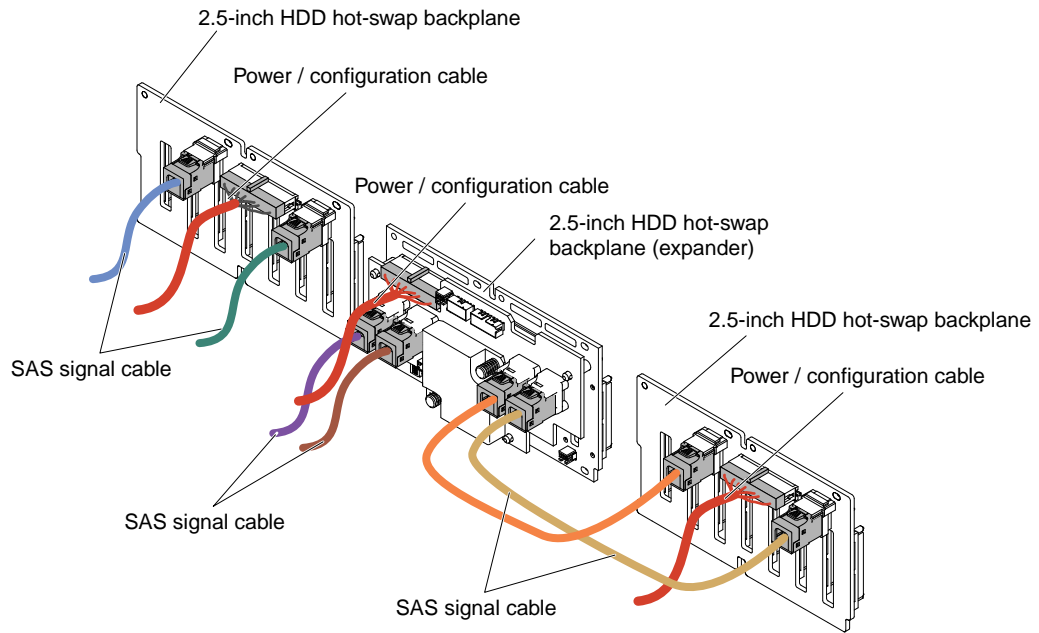

Figure 269. Cable connection

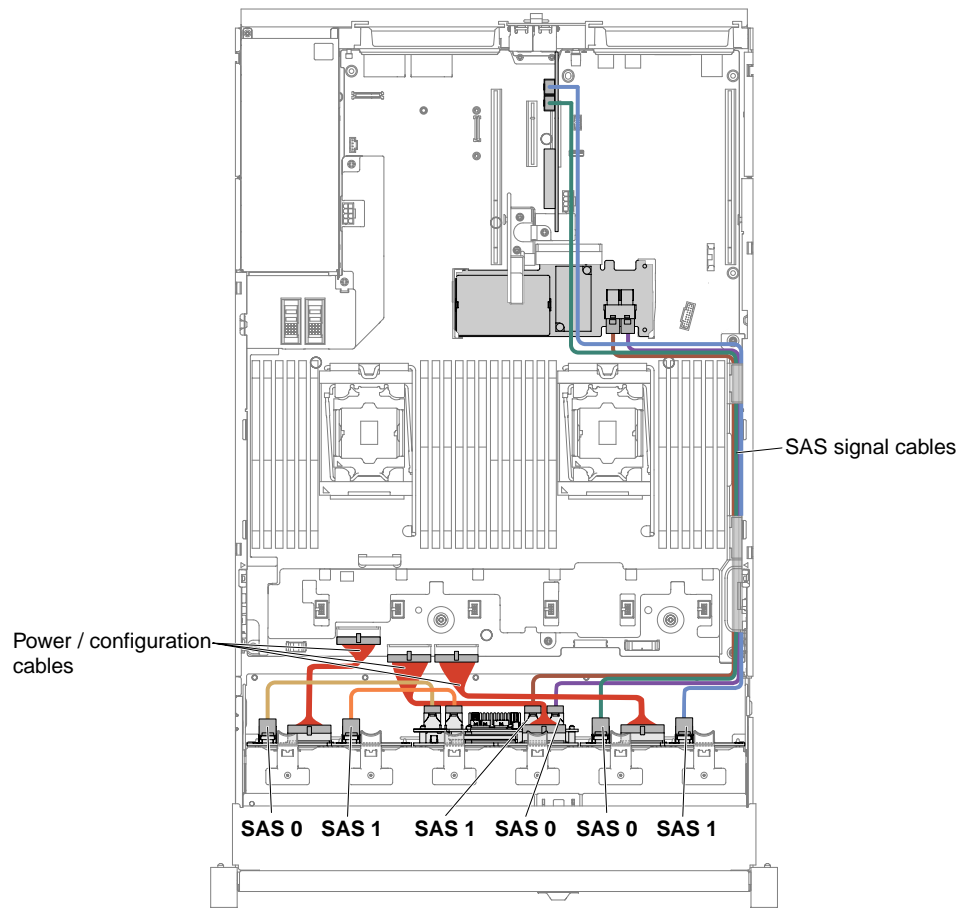

Figure 270. Cable routing

Step 9. If you removed the fan cage, install it. (See “Replacing the fan cage assembly” on page 173).

Step 10. Insert the hard disk drives and the fillers the rest of the way into the bays.

## Installing a 8x 2.5-inch hot-swap HDD assembly with expander kit

Use this information to install a 8x 2.5-inch hot-swap HDD assembly kit with expander.

You can install a Lenovo Storage DX8200 8x 2.5-inch hot-swap HDD assembly with expander kit to add eight additional 2.5-inch hot-swap hard disk drives in the server. See <http://www.lenovo.com/serverproven/> for a list of supported optional devices. To order a 8x 2.5-inch hot-swap HDD assembly kit with expander, contact your sales representative or reseller.

The 8x 2.5-inch hot-swap HDD assembly with expander kit contains the following components:

- Eight 2.5-inch HDD fillers
- One expander
- Two power/configuration cables (230 mm)
- One power/configuration cable (260 mm)
- One Mini-SAS HD Y-cable (580/590 mm)
- One Mini-SAS HD cable (350 mm)
- One Mini-SAS HD cable (150 mm)

- Two Mini-SAS HD cables (250 mm)

**Note:** The 8x 2.5-inch hot-swap HDD assembly with expander kit including structural parts and Tier 1 parts.

To install a 8x 2.5-inch hot-swap HDD assembly with expander kit, complete the following steps:

- Step 1. Read the safety information that begins on “Safety” on page v and “Installation guidelines” on page 287.
- Step 2. Turn off the server and peripheral devices and disconnect the power cords and all external cables, if necessary.
- Step 3. Remove the top cover (see “Removing the top cover” on page 144).
- Step 4. Remove the two 4-drive filler panels.

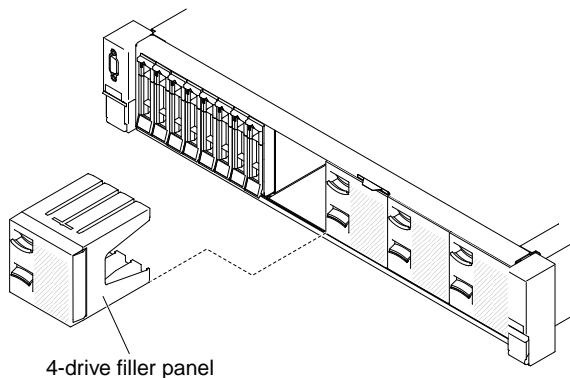

Figure 271. Filler panels

- Step 5. To obtain more working room, remove the fan cage (see “Removing the fan cage assembly” on page 172).
- Step 6. Pull the hard disk drives or fillers out of the server slightly to disengage them from the backplanes. For more information, (see “Removing a hot-swap hard disk drive” on page 153).
- Step 7. Disconnect all cables from the system board and backplanes.
- Step 8. Install the new backplane in slot 2 or slot 3 depending on your configuration. Insert the backplane tabs into slots on the bottom of the cage and push the backplane forward into the release latch (on top of the backplane cage) until the backplane is locked in place.

**Note:** You can connect the cables to the drive backplane before installing the backplane onto the cage or you can connect the cables after you install the backplane, if that is easier for you.



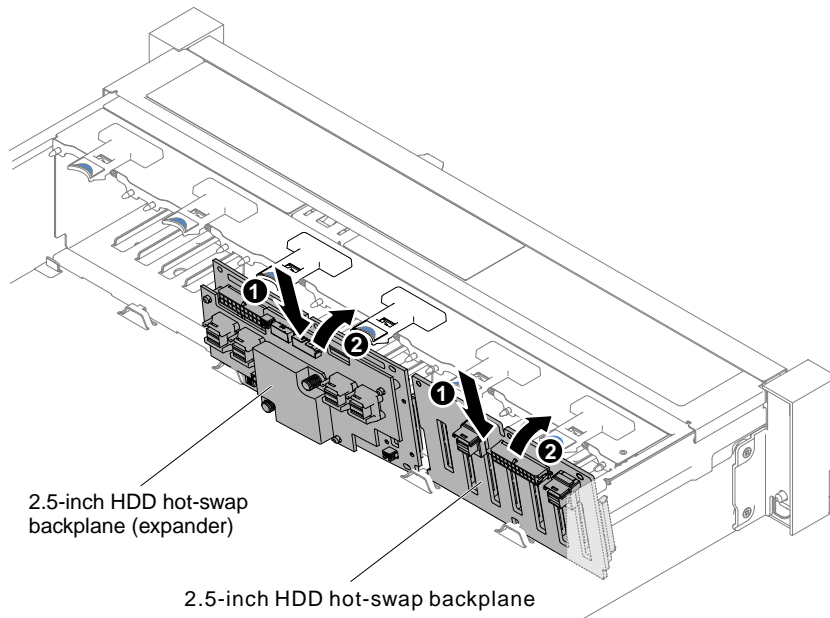

Figure 272. Expander installation

Step 9. Connect Mini-SAS HD cables, power/configuration and Mini-SAS HD Y-cable which come with the option kit to the backplanes and the system board.

- If you are installing the new expander in slot 2, connect and route cables as the following illustrations.

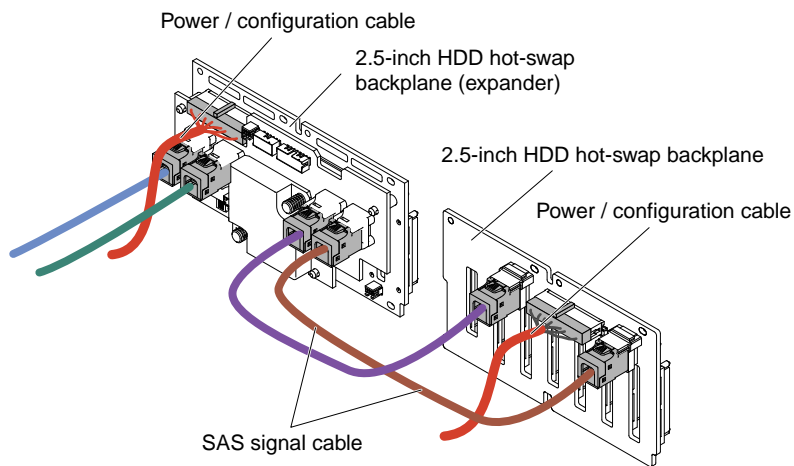

Figure 273. Cable connections

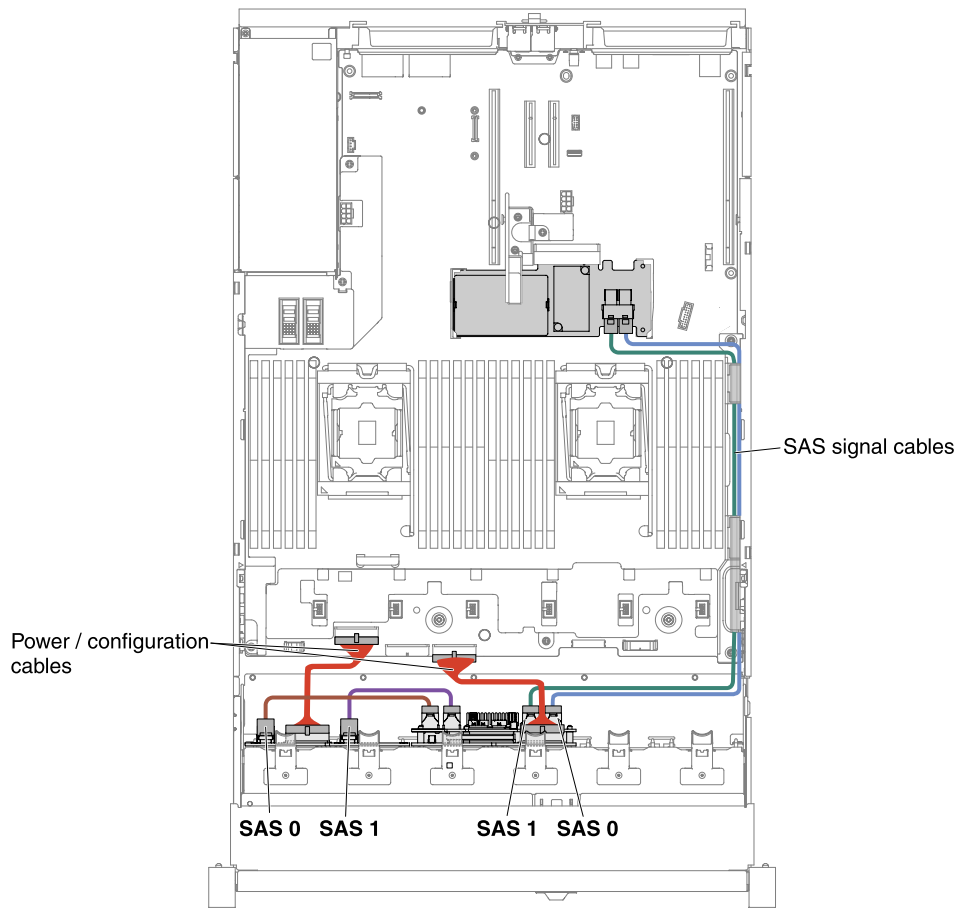

Figure 274. Cable routing

- If you are installing the new expander in slot 3, connect and route cables as the following illustrations.
  1. If the backplane is installed in slot 2, connect and route cables as the following illustrations.

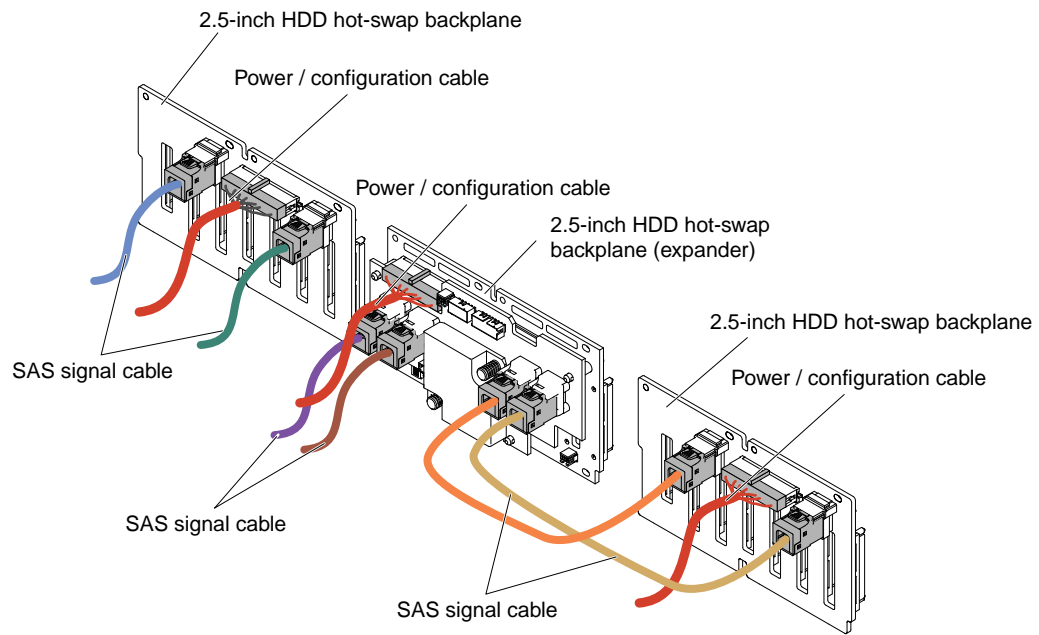

Figure 275. Cable connections

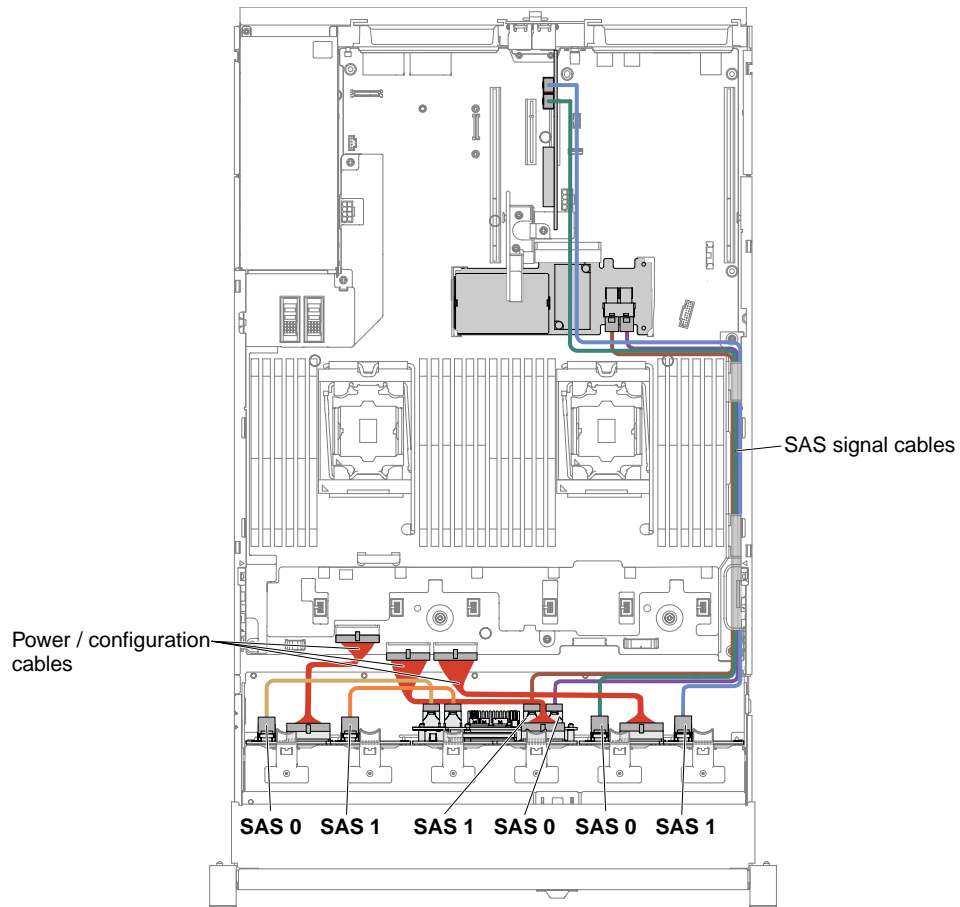

Figure 276. Cable routing

2. If the expander is installed in slot 2, connect and route cables as the following illustrations.

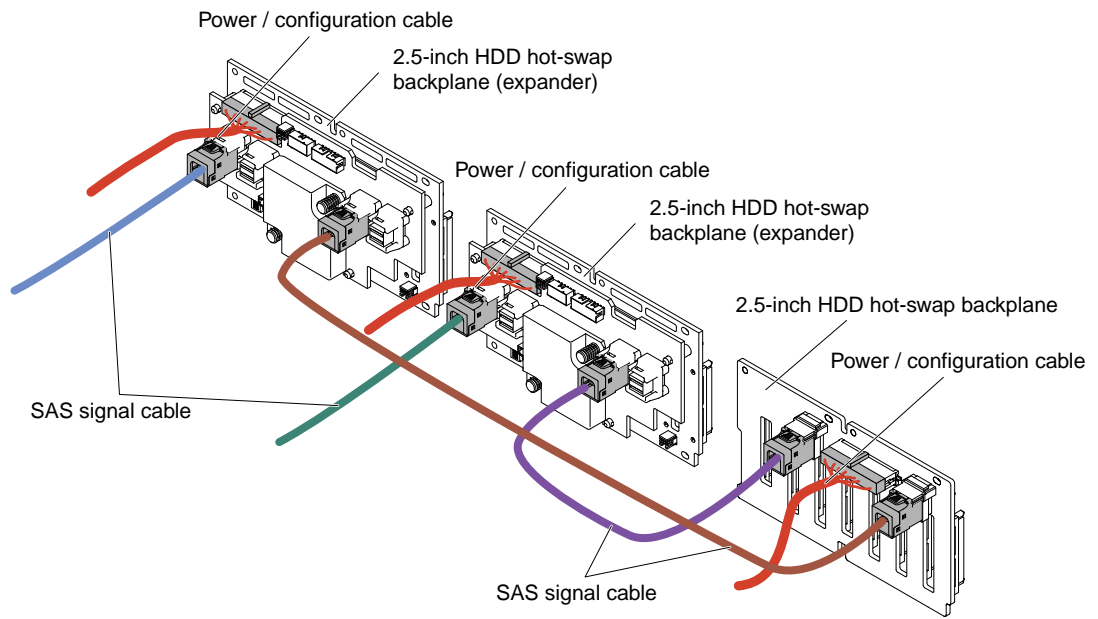

Figure 277. Cable connections

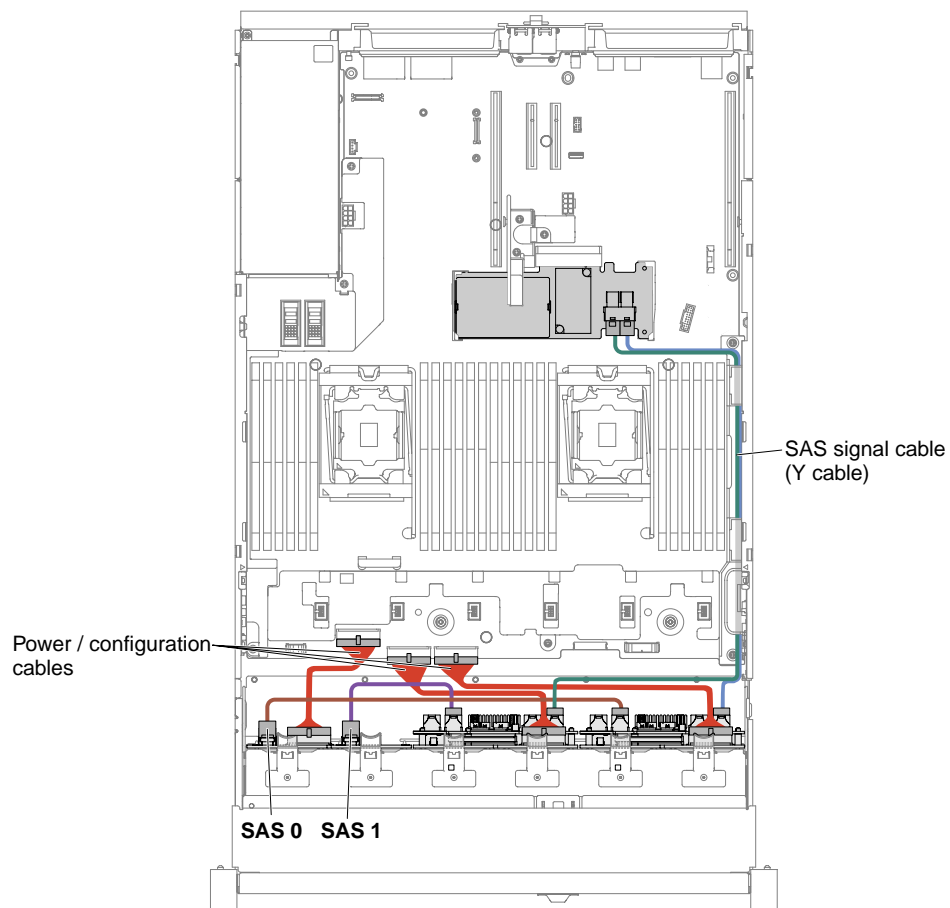

Figure 278. Cable connections

- Step 10. If you removed the fan cage assembly, install it. (See “Replacing the fan cage assembly” on page 173).
- Step 11. Insert the hard disk drives and the fillers the rest of the way into the bays.
- Step 12. Install the top cover (see “Replacing the top cover” on page 146).
- Step 13. Slide the server into the rack.
- Step 14. Reconnect the power cords and any cables that you removed.
- Step 15. Turn on the peripheral devices and the server.

## Installing a 4x 2.5-inch NVMe PCIe SSD upgrade kit

Use this information to install a 4x 2.5-inch NVMe PCIe SSD upgrade kit.

To order a 4x 2.5-inch NVMe PCIe SSD upgrade kit, contact your sales representative or reseller.

The 4x 2.5-inch NVMe PCIe SSD upgrade kit contains the following components:

- Four signal cables
- One power/configuration cable
- One backplane assembly

To install the 4x 2.5-inch NVMe PCIe SSD upgrade kit in the server, complete the following steps.

- Step 1. Read the safety information that begins on “Safety” on page v and “Installation guidelines” on page 287.
- Step 2. Turn off the server and peripheral devices and disconnect the power cords and all external cables, if necessary.
- Step 3. Remove the cover (see “Removing the top cover” on page 144).
- Step 4. Remove the two 4-drive filler panels according to your configuration.

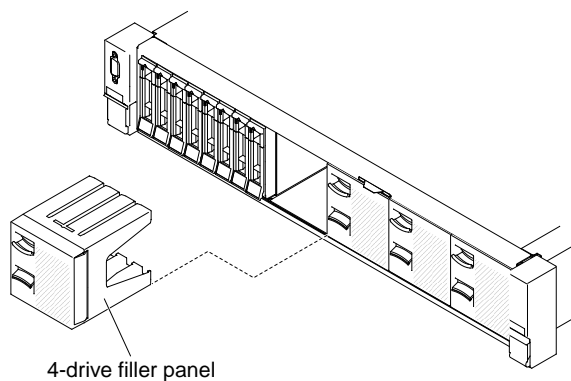

Figure 279. Filler panels

- Step 5. To obtain more working room, remove the fan cage (see “Removing the fan cage assembly” on page 172).
- Step 6. Install the new backplanes. (See “Replacing the 2.5-inch simple-swap backplate assembly/hot-swap hard disk drive backplane” on page 242).
- Step 7. Connect the power/configuration and signal cables to the backplane.
  - 8x 2.5-inch HDD + 4x 2.5-inch NVMe PCIe SSD

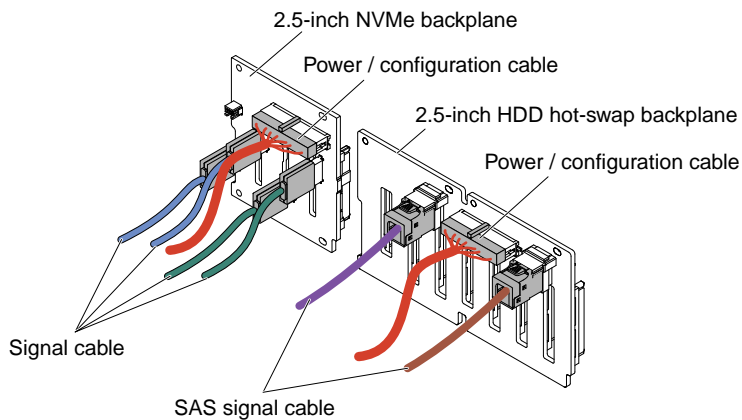

Figure 280. Cable connections

- 16x 2.5-inch HDD + 4x 2.5-inch NVMe PCIe SSD

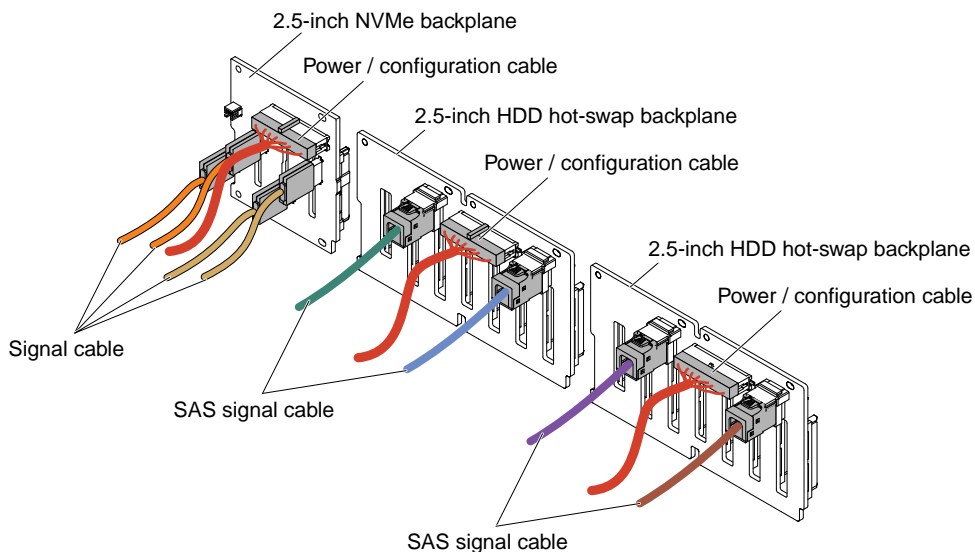

Figure 281. Cable connections

- Step 8. Touch the static-protective package that contains the NVMe adapter to any unpainted metal surface on the server. Then, remove the NVMe adapter from the package.
- Step 9. Remove the PCI riser-card assemblies. (see “Removing a riser-card assembly” on page 180).
- Step 10. Install NVMe adapters in the connectors on the PCI riser card (see “Replacing an adapter” on page 189).

**Attention:** Incomplete insertion might cause damage to the server or the adapter.

- Step 11. Connect the four signal cables to the connectors on the NVMe adapter:

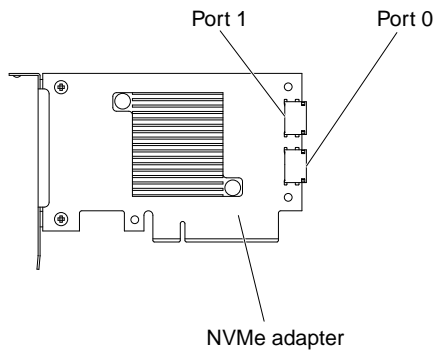

Figure 282. NVMe adapter connectors

Step 12. Align and install the PCI riser-card assemblies in the server (see “Replacing a riser-card assembly” on page 181).

Step 13. Route the cables underneath the cable retention.

- 8x 2.5-inch HDD + 4x 2.5-inch NVMe PCIe SSD

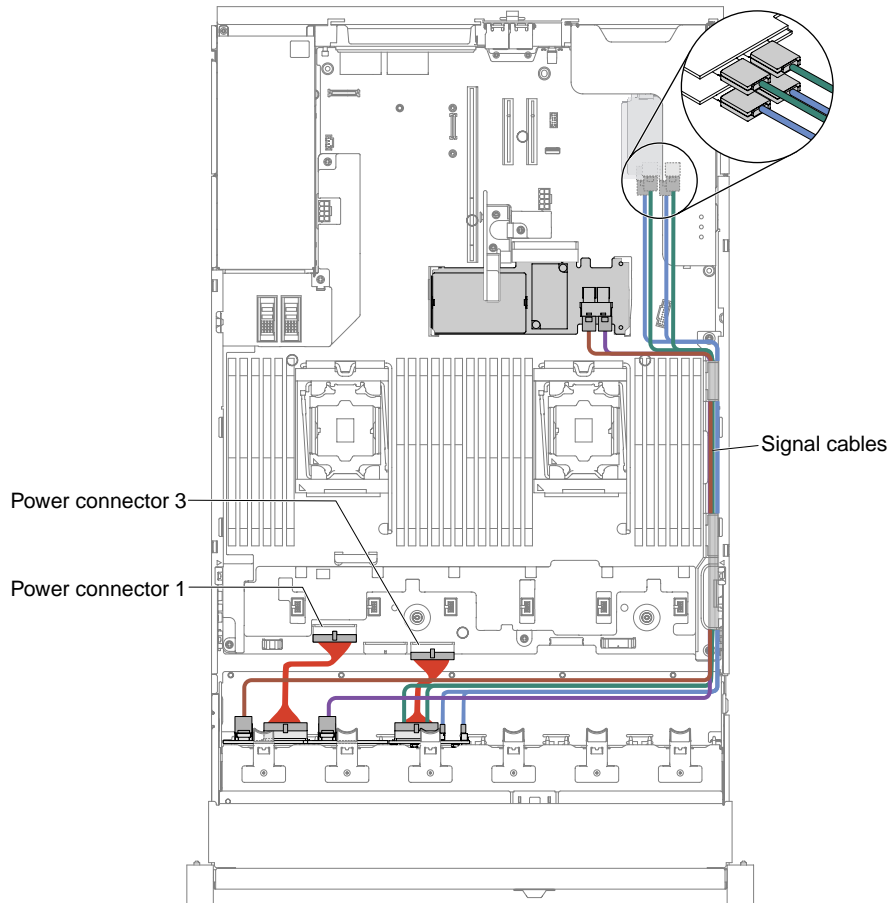

Figure 283. Cable routing

**Notes:**

1. For the power cable connection, the NVMe backplane can only connect to the power connector 3.

2. There might be 3 or 4 power connectors on the system board depending on your configuration. However, this difference will not affect the cable routing. Follow the following illustrations to complete your cable routing.
- 16x 2.5-inch HDD + 4x 2.5-inch NVMe PCIe SSD

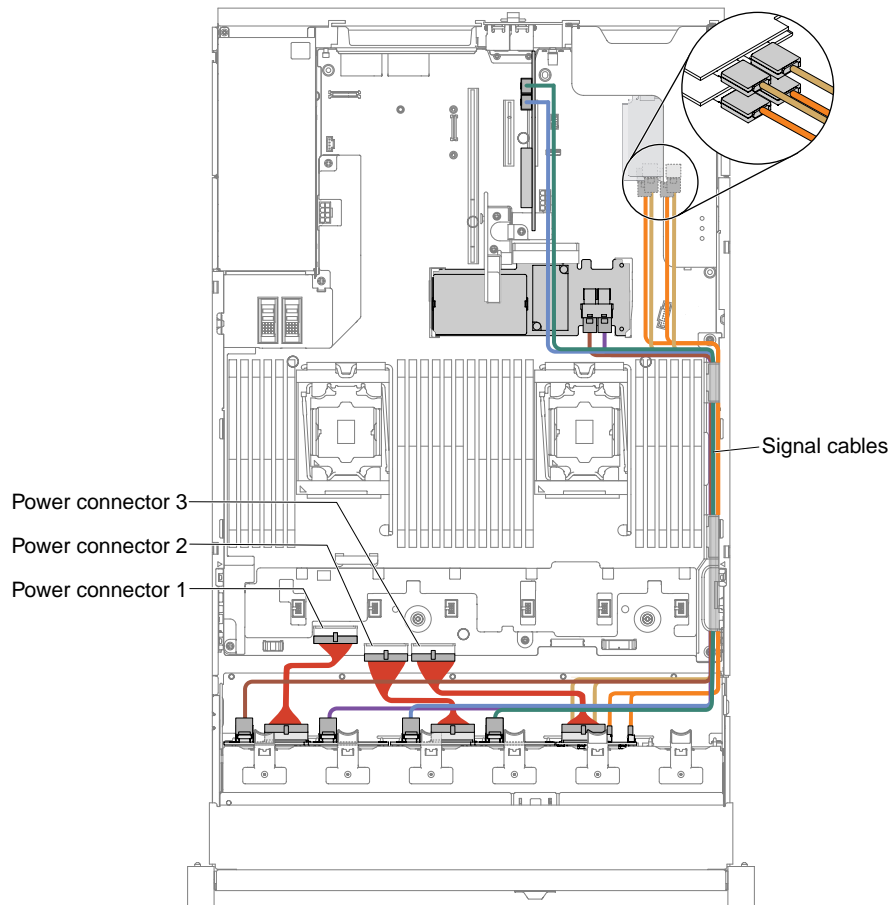

Figure 284. Cable routing

**Notes:**

1. For the power cable connection, the NVMe backplane can only connect to the power connector 3.
2. There might be 3 or 4 power connectors on the system board depending on your configuration. However, this difference will not affect the cable routing. Follow the following illustrations to complete your cable routing.

Step 14. If you removed the fan cage, install it back to the server. (See “Replacing the fan cage assembly” on page 173).

Step 15. Insert the hard disk drives and the fillers the rest of the way into the bays. (See “Replacing a hot-swap hard disk drive” on page 154).

## Installing a PCIe thermal solution kit

Use this information to install a PCIe thermal solution kit.

**Note:** If you are installing the Dual Port 10GB-T Ethernet Daughter Card (Option number is 00D1994) in the server, you have to purchase and install a Lenovo Storage DX8200 PCIe thermal solution kit. See <http://>



[www.lenovo.com/serverproven/](http://www.lenovo.com/serverproven/) for a list of supported optional devices. To order a PCIe thermal solution kit, contact your sales representative or reseller.

The PCIe thermal solution kit contains one air baffle.

To install a PCIe thermal solution kit, complete the following steps:

- Step 1. Read the safety information that begins on “Safety” on page v and “Installation guidelines” on page 287.
- Step 2. Turn off the server and peripheral devices and disconnect the power cords and all external cables, if necessary.
- Step 3. Remove the top cover (see “Removing the top cover” on page 144).
- Step 4. Align the air baffle tab with the slot on the right side of the chassis; then, lower the air baffle into the server. Press the air baffle down until it is securely seated.

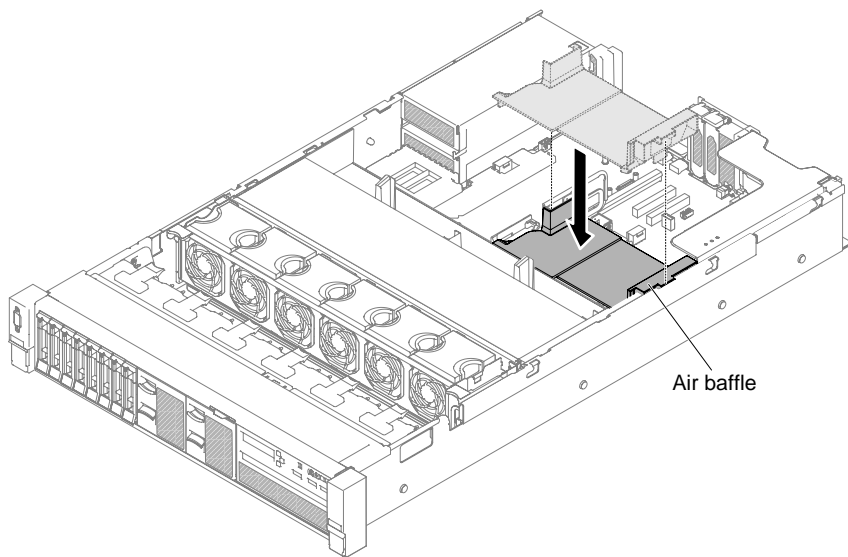

Figure 285. Air baffle installation

- Step 5. Install the top cover (see “Replacing the top cover” on page 146).
- Step 6. Slide the server into the rack.
- Step 7. Reconnect the power cords and any cables that you removed.
- Step 8. Turn on the peripheral devices and the server.

## Installing a 2.5-inch advanced operation panel assembly kit

Use this information to install a 2.5-inch advanced operation panel assembly kit.

The 2.5-inch advanced operation panel assembly kit contains one 2.5-inch advanced operation panel assembly.

To install a 2.5-inch advanced operation panel assembly, complete the following steps:

- Step 1. Read the safety information that begins on “Safety” on page v and “Installation guidelines” on page 287.

- Step 2. Turn off the server and peripheral devices and disconnect the power cords and all external cables, if necessary.
- Step 3. Remove the top cover (see “Removing the top cover” on page 144).
- Step 4. Remove the screw that secures the front control panel assembly to the chassis. Then carefully push the front control panel assembly out of the server and set it aside.

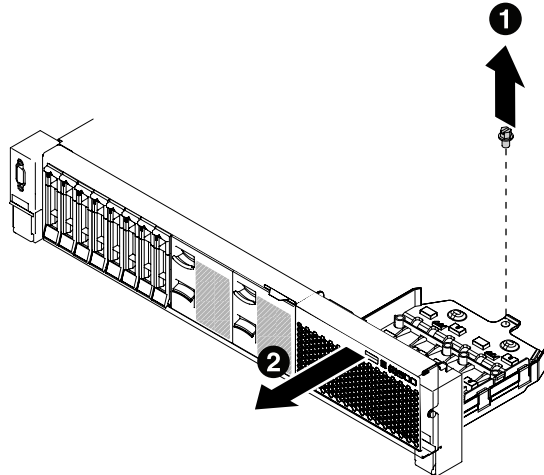

Figure 286. Front control panel assembly removal

- Step 5. Install the 2.5-inch advanced operation panel assembly. See “Replacing the media cage (also called lightpath LCD operation panel assembly)” on page 178.
- Step 6. Install the top cover (see “Replacing the top cover” on page 146).
- Step 7. Slide the server into the rack.
- Step 8. Reconnect the power cords and any cables that you removed.
- Step 9. Turn on the peripheral devices and the server.

## Updating the server configuration

Use this information to update the server configuration.

When you start the server for the first time after you add or remove a device, you might receive a message that the configuration has changed. The Setup Utility starts automatically so that you can save the new configuration settings.

Some optional devices have device drivers that you must install. For information about installing device drivers, see the documentation that comes with each device.

If the server has an optional RAID adapter and you have installed or removed a hard disk drive, see the documentation that comes with the RAID adapter for information about reconfiguring the disk arrays.

If you have installed a USB hypervisor memory key on the SAS riser-card, see the user's guide that comes with the hypervisor memory key. Hypervisor enables guest operating systems to function on the server.

For information about configuring the integrated Gigabit Ethernet controller, see “Configuring the Ethernet controller” on page 55.

## Instructions for Business Partners

Instructions for Business Partners on verifying the newly installed devices by running the Dynamic System Analysis (DSA) stress test.

In addition to the instructions in this chapter for installing optional hardware devices, updating firmware and device drivers, and completing the installation, Business Partners must also complete the following steps:

1. After you have confirmed that the server starts correctly and recognizes the newly installed devices and that no error LEDs are lit, run the Dynamic System Analysis (DSA) stress test. For information about using DSA, see “Dynamic System Analysis” on page 75.
2. Shut down and restart the server multiple times to ensure that the server is correctly configured and functions correctly with the newly installed devices.
3. Save the DSA log as a file and send it to Lenovo. For information about transferring data and logs, see “How to send DSA data” on page 311.
4. To ship the server, repackage it in the original undamaged packing material and observe Lenovo procedures for shipping.

Support information for Business Partners is available at <http://www.ibm.com/partnerworld>.

## How to send DSA data

You can use the Enhanced Customer Data Repository to send diagnostic data to IBM.

Before you send diagnostic data to IBM, read the terms of use at <http://www.ibm.com/de/support/ecurep/terms.html>.

You can use any of the following methods to send diagnostic data:

- **Standard upload:**  
[http://www.ibm.com/de/support/ecurep/send\\_http.html](http://www.ibm.com/de/support/ecurep/send_http.html)
- **Standard upload with the system serial number:**  
[http://www.ecurep.ibm.com/app/upload\\_hw](http://www.ecurep.ibm.com/app/upload_hw)
- **Secure upload:**  
[http://www.ibm.com/de/support/ecurep/send\\_http.html#secure](http://www.ibm.com/de/support/ecurep/send_http.html#secure)
- **Secure upload with the system serial number:**  
[https://www.ecurep.ibm.com/app/upload\\_hw](https://www.ecurep.ibm.com/app/upload_hw)



---

## Appendix A. Integrated management module II (IMM2) error messages

When a hardware event is detected by the IMM on the server, the IMM logs that event in the system-event log in the server.

For each event code, the following fields are displayed:

### Event identifier

A hexadecimal identifier that uniquely identifies an event or class of events. In this documentation, the event identifiers are prefixed with 0x and followed by eight characters.

### Event description

The logged message string that appears for an event. When the event string is displayed in the system-event log, information such as a specific component is displayed. In this documentation, that additional information appears as variables, such as [arg1] or [arg2].

### Explanation

Additional information to explain why the event occurred.

### Severity

An indication of the level of concern for the condition. In the system-event log, severity is abbreviated to the first character. The following severities can be displayed.

#### Info:

The event was recorded for audit purposes, usually a user action or a change of states that is normal behavior.

#### Warning:

The event is not as severe as an error, but if possible, the condition should be corrected before it becomes an error. It might also be a condition that requires additional monitoring or maintenance.

#### Error:

The event is a failure or critical condition that impairs service or an expected function.

### Alert Category

Similar events are grouped together in categories. The alert category is in the following format:

*severity - device*

*severity* is one of the following severity levels:

- **Critical:** A key component in the server is no longer functioning.
- **Warning:** The event might progress to a critical level.
- **System:** The event is the result of a system error or a configuration change.

*device* is the specific device in the server that caused the event to be generated.

### Serviceable

Whether user action is required to correct the problem.

### CIM Information

The prefix of the message ID and the sequence number that is used by the CIM message registry.

### SNMP Trap ID

The SNMP trap ID that is found in the SNMP alert management information base (MIB).

### Automatically contact Service

If this field is set to **Yes**, and you have enabled Electronic Service Agent (ESA), Lenovo Support will be notified automatically if the event is generated.

While you wait for Lenovo Support to call, you can perform the recommended actions for the event.

### User response

The actions that you should perform to solve the event.

Perform the steps listed in this section in the order shown until the problem is solved. After you perform all of the actions that are described in this field, if you cannot solve the problem, contact Lenovo Support.

**Note:** This list includes error codes and messages that might not apply to this machine type and model.

Below is the list of IMM2 error messages and suggested actions to correct the detected server problems. For more information about IMM2, see the *Integrated Management Module II User's Guide* at [http://publib.boulder.ibm.com/infocenter/systemx/documentation/topic/com.lenovo.sysx.imm2.doc/printable\\_doc.html](http://publib.boulder.ibm.com/infocenter/systemx/documentation/topic/com.lenovo.sysx.imm2.doc/printable_doc.html).

---

## IMM Events that automatically notify Support

You can configure the IBM Flex System Manager or the CMM to automatically notify Support (also known as *call home*) if certain types of errors are encountered. If you have configured this function, see the table for a list of events that automatically notify Support.

Table 20. Events that automatically notify Support

Event ID	Message String	Automatically Notify Support
40000086-00000000	Test Call Home Generated by user [arg1].	Yes
40000087-00000000	Manual Call Home by user [arg1]: [arg2].	Yes
80010202-0701ffff	Numeric sensor [NumericSensorElementName] going low (lower critical) has asserted. (CMOS Battery)	Yes
80010902-0701ffff	Numeric sensor [NumericSensorElementName] going high (upper critical) has asserted. (SysBrd 12V)	Yes
806f0021-2201ffff	Fault in slot [PhysicalConnectorSystemElementName] on system [ComputerSystemElementName]. (No Op ROM Space)	Yes
806f0021-2582ffff	Fault in slot [PhysicalConnectorSystemElementName] on system [ComputerSystemElementName]. (All PCI Error)	Yes
806f0021-2c01ffff	Fault in slot [PhysicalConnectorSystemElementName] on system [ComputerSystemElementName]. (ML2 Card Fault)	Yes
806f0021-3001ffff	Fault in slot [PhysicalConnectorSystemElementName] on system [ComputerSystemElementName]. (Internal RAID)	Yes
806f0108-0a01ffff	[PowerSupplyElementName] has Failed. (Power Supply 1)	Yes
806f0108-0a02ffff	[PowerSupplyElementName] has Failed. (Power Supply 2)	Yes
806f010c-2001ffff	Uncorrectable error detected for [PhysicalMemoryElementName] on Subsystem [MemoryElementName]. (DIMM 1)	Yes

Table 20. Events that automatically notify Support (continued)

Event ID	Message String	Automatically Notify Support
806f010c-2002ffff	Uncorrectable error detected for [PhysicalMemoryElementName] on Subsystem [MemoryElementName]. (DIMM 2)	Yes
806f010c-2003ffff	Uncorrectable error detected for [PhysicalMemoryElementName] on Subsystem [MemoryElementName]. (DIMM 3)	Yes
806f010c-2004ffff	Uncorrectable error detected for [PhysicalMemoryElementName] on Subsystem [MemoryElementName]. (DIMM 4)	Yes
806f010c-2005ffff	Uncorrectable error detected for [PhysicalMemoryElementName] on Subsystem [MemoryElementName]. (DIMM 5)	Yes
806f010c-2006ffff	Uncorrectable error detected for [PhysicalMemoryElementName] on Subsystem [MemoryElementName]. (DIMM 6)	Yes
806f010c-2007ffff	Uncorrectable error detected for [PhysicalMemoryElementName] on Subsystem [MemoryElementName]. (DIMM 7)	Yes
806f010c-2008ffff	Uncorrectable error detected for [PhysicalMemoryElementName] on Subsystem [MemoryElementName]. (DIMM 8)	Yes
806f010c-2009ffff	Uncorrectable error detected for [PhysicalMemoryElementName] on Subsystem [MemoryElementName]. (DIMM 9)	Yes
806f010c-200affff	Uncorrectable error detected for [PhysicalMemoryElementName] on Subsystem [MemoryElementName]. (DIMM 10)	Yes
806f010c-200bffff	Uncorrectable error detected for [PhysicalMemoryElementName] on Subsystem [MemoryElementName]. (DIMM 11)	Yes
806f010c-200cffff	Uncorrectable error detected for [PhysicalMemoryElementName] on Subsystem [MemoryElementName]. (DIMM 12)	Yes
806f010c-200dffff	Uncorrectable error detected for [PhysicalMemoryElementName] on Subsystem [MemoryElementName]. (DIMM 13)	Yes
806f010c-200effff	Uncorrectable error detected for [PhysicalMemoryElementName] on Subsystem [MemoryElementName]. (DIMM 14)	Yes
806f010c-200fffff	Uncorrectable error detected for [PhysicalMemoryElementName] on Subsystem [MemoryElementName]. (DIMM 15)	Yes
806f010c-2010ffff	Uncorrectable error detected for [PhysicalMemoryElementName] on Subsystem [MemoryElementName]. (DIMM 16)	Yes

Table 20. Events that automatically notify Support (continued)

Event ID	Message String	Automatically Notify Support
806f010c-2011ffff	Uncorrectable error detected for [PhysicalMemoryElementName] on Subsystem [MemoryElementName]. (DIMM 17)	Yes
806f010c-2012ffff	Uncorrectable error detected for [PhysicalMemoryElementName] on Subsystem [MemoryElementName]. (DIMM 18)	Yes
806f010c-2013ffff	Uncorrectable error detected for [PhysicalMemoryElementName] on Subsystem [MemoryElementName]. (DIMM 19)	Yes
806f010c-2014ffff	Uncorrectable error detected for [PhysicalMemoryElementName] on Subsystem [MemoryElementName]. (DIMM 20)	Yes
806f010c-2015ffff	Uncorrectable error detected for [PhysicalMemoryElementName] on Subsystem [MemoryElementName]. (DIMM 21)	Yes
806f010c-2016ffff	Uncorrectable error detected for [PhysicalMemoryElementName] on Subsystem [MemoryElementName]. (DIMM 22)	Yes
806f010c-2017ffff	Uncorrectable error detected for [PhysicalMemoryElementName] on Subsystem [MemoryElementName]. (DIMM 23)	Yes
806f010c-2018ffff	Uncorrectable error detected for [PhysicalMemoryElementName] on Subsystem [MemoryElementName]. (DIMM 24)	Yes
806f010c-2581ffff	Uncorrectable error detected for [PhysicalMemoryElementName] on Subsystem [MemoryElementName]. (All DIMMS)	Yes
806f010d-0400ffff	The Drive [StorageVolumeElementName] has been disabled due to a detected fault. (Drive 0)	Yes
806f010d-0401ffff	The Drive [StorageVolumeElementName] has been disabled due to a detected fault. (Drive 1)	Yes
806f010d-0402ffff	The Drive [StorageVolumeElementName] has been disabled due to a detected fault. (Drive 2)	Yes
806f010d-0403ffff	The Drive [StorageVolumeElementName] has been disabled due to a detected fault. (Drive 3)	Yes
806f010d-0404ffff	The Drive [StorageVolumeElementName] has been disabled due to a detected fault. (Drive 4)	Yes
806f010d-0405ffff	The Drive [StorageVolumeElementName] has been disabled due to a detected fault. (Drive 5)	Yes
806f010d-0406ffff	The Drive [StorageVolumeElementName] has been disabled due to a detected fault. (Drive 6)	Yes
806f010d-0407ffff	The Drive [StorageVolumeElementName] has been disabled due to a detected fault. (Drive 7)	Yes
806f010d-0408ffff	The Drive [StorageVolumeElementName] has been disabled due to a detected fault. (Drive 8)	Yes



Table 20. Events that automatically notify Support (continued)

Event ID	Message String	Automatically Notify Support
806f010d-0409ffff	The Drive [StorageVolumeElementName] has been disabled due to a detected fault. (Drive 9)	Yes
806f010d-040affff	The Drive [StorageVolumeElementName] has been disabled due to a detected fault. (Drive 10)	Yes
806f010d-040bffff	The Drive [StorageVolumeElementName] has been disabled due to a detected fault. (Drive 11)	Yes
806f010d-040cffff	The Drive [StorageVolumeElementName] has been disabled due to a detected fault. (Drive 12)	Yes
806f010d-040dffff	The Drive [StorageVolumeElementName] has been disabled due to a detected fault. (Drive 13)	Yes
806f010d-040effff	The Drive [StorageVolumeElementName] has been disabled due to a detected fault. (Drive 14)	Yes
806f010d-040fffff	The Drive [StorageVolumeElementName] has been disabled due to a detected fault. (Drive 15)	Yes
806f010d-0410ffff	The Drive [StorageVolumeElementName] has been disabled due to a detected fault. (Drive 16)	Yes
806f010d-0411ffff	The Drive [StorageVolumeElementName] has been disabled due to a detected fault. (Drive 17)	Yes
806f010d-0412ffff	The Drive [StorageVolumeElementName] has been disabled due to a detected fault. (Drive 18)	Yes
806f010d-0413ffff	The Drive [StorageVolumeElementName] has been disabled due to a detected fault. (Drive 19)	Yes
806f010d-0414ffff	The Drive [StorageVolumeElementName] has been disabled due to a detected fault. (Drive 20)	Yes
806f010d-0415ffff	The Drive [StorageVolumeElementName] has been disabled due to a detected fault. (Drive 21)	Yes
806f010d-0416ffff	The Drive [StorageVolumeElementName] has been disabled due to a detected fault. (Drive 22)	Yes
806f010d-0417ffff	The Drive [StorageVolumeElementName] has been disabled due to a detected fault. (Drive 23)	Yes
806f010d-0418ffff	The Drive [StorageVolumeElementName] has been disabled due to a detected fault. (Drive 24)	Yes
806f010d-0419ffff	The Drive [StorageVolumeElementName] has been disabled due to a detected fault. (Drive 25)	Yes
806f010d-041affff	The Drive [StorageVolumeElementName] has been disabled due to a detected fault. (Drive 26)	Yes
806f010d-041bffff	The Drive [StorageVolumeElementName] has been disabled due to a detected fault. (Drive 27)	Yes
806f010d-041cffff	The Drive [StorageVolumeElementName] has been disabled due to a detected fault. (Drive 28)	Yes
806f010d-041dffff	The Drive [StorageVolumeElementName] has been disabled due to a detected fault. (Drive 29)	Yes

Table 20. Events that automatically notify Support (continued)

Event ID	Message String	Automatically Notify Support
806f010d-041effff	The Drive [StorageVolumeElementName] has been disabled due to a detected fault. (Drive 30)	Yes
806f010d-041ffff	The Drive [StorageVolumeElementName] has been disabled due to a detected fault. (Drive 31)	Yes
806f011b-0701ffff	The connector [PhysicalConnectorElementName] has encountered a configuration error. (Front USB)	Yes
806f011b-0c01ffff	The connector [PhysicalConnectorElementName] has encountered a configuration error. (FP LCD Cable)	Yes
806f011b-2502ffff	The connector [PhysicalConnectorElementName] has encountered a configuration error. (nvDIMM 02 Cable)	Yes
806f011b-2505ffff	The connector [PhysicalConnectorElementName] has encountered a configuration error. (nvDIMM 05 Cable)	Yes
806f011b-2508ffff	The connector [PhysicalConnectorElementName] has encountered a configuration error. (nvDIMM 08 Cable)	Yes
806f011b-250bffff	The connector [PhysicalConnectorElementName] has encountered a configuration error. (nvDIMM 11 Cable)	Yes
806f0207-0301ffff	[ProcessorElementName] has Failed with FRB1/BIST condition. (CPU 1)	Yes
806f0207-0302ffff	[ProcessorElementName] has Failed with FRB1/BIST condition. (CPU 2)	Yes
806f0207-2584ffff	[ProcessorElementName] has Failed with FRB1/BIST condition. (All CPUs)	Yes
806f020d-0400ffff	Failure Predicted on drive [StorageVolumeElementName] for array [ComputerSystemElementName]. (Drive 0)	Yes
806f020d-0401ffff	Failure Predicted on drive [StorageVolumeElementName] for array [ComputerSystemElementName]. (Drive 1)	Yes
806f020d-0402ffff	Failure Predicted on drive [StorageVolumeElementName] for array [ComputerSystemElementName]. (Drive 2)	Yes
806f020d-0403ffff	Failure Predicted on drive [StorageVolumeElementName] for array [ComputerSystemElementName]. (Drive 3)	Yes
806f020d-0404ffff	Failure Predicted on drive [StorageVolumeElementName] for array [ComputerSystemElementName]. (Drive 4)	Yes
806f020d-0405ffff	Failure Predicted on drive [StorageVolumeElementName] for array [ComputerSystemElementName]. (Drive 5)	Yes
806f020d-0406ffff	Failure Predicted on drive [StorageVolumeElementName] for array [ComputerSystemElementName]. (Drive 6)	Yes
806f020d-0407ffff	Failure Predicted on drive [StorageVolumeElementName] for array [ComputerSystemElementName]. (Drive 7)	Yes
806f020d-0408ffff	Failure Predicted on drive [StorageVolumeElementName] for array [ComputerSystemElementName]. (Drive 8)	Yes
806f020d-0409ffff	Failure Predicted on drive [StorageVolumeElementName] for array [ComputerSystemElementName]. (Drive 9)	Yes

Table 20. Events that automatically notify Support (continued)

Event ID	Message String	Automatically Notify Support
806f020d-040affff	Failure Predicted on drive [StorageVolumeElementName] for array [ComputerSystemElementName]. (Drive 10)	Yes
806f020d-040bffff	Failure Predicted on drive [StorageVolumeElementName] for array [ComputerSystemElementName]. (Drive 11)	Yes
806f020d-040cffff	Failure Predicted on drive [StorageVolumeElementName] for array [ComputerSystemElementName]. (Drive 12)	Yes
806f020d-040dffff	Failure Predicted on drive [StorageVolumeElementName] for array [ComputerSystemElementName]. (Drive 13)	Yes
806f020d-040effff	Failure Predicted on drive [StorageVolumeElementName] for array [ComputerSystemElementName]. (Drive 14)	Yes
806f020d-040fffff	Failure Predicted on drive [StorageVolumeElementName] for array [ComputerSystemElementName]. (Drive 15)	Yes
806f020d-0410ffff	Failure Predicted on drive [StorageVolumeElementName] for array [ComputerSystemElementName]. (Drive 16)	Yes
806f020d-0411ffff	Failure Predicted on drive [StorageVolumeElementName] for array [ComputerSystemElementName]. (Drive 17)	Yes
806f020d-0412ffff	Failure Predicted on drive [StorageVolumeElementName] for array [ComputerSystemElementName]. (Drive 18)	Yes
806f020d-0413ffff	Failure Predicted on drive [StorageVolumeElementName] for array [ComputerSystemElementName]. (Drive 19)	Yes
806f020d-0414ffff	Failure Predicted on drive [StorageVolumeElementName] for array [ComputerSystemElementName]. (Drive 20)	Yes
806f020d-0415ffff	Failure Predicted on drive [StorageVolumeElementName] for array [ComputerSystemElementName]. (Drive 21)	Yes
806f020d-0416ffff	Failure Predicted on drive [StorageVolumeElementName] for array [ComputerSystemElementName]. (Drive 22)	Yes
806f020d-0417ffff	Failure Predicted on drive [StorageVolumeElementName] for array [ComputerSystemElementName]. (Drive 23)	Yes
806f020d-0418ffff	Failure Predicted on drive [StorageVolumeElementName] for array [ComputerSystemElementName]. (Drive 24)	Yes
806f020d-0419ffff	Failure Predicted on drive [StorageVolumeElementName] for array [ComputerSystemElementName]. (Drive 25)	Yes
806f020d-041affff	Failure Predicted on drive [StorageVolumeElementName] for array [ComputerSystemElementName]. (Drive 26)	Yes
806f020d-041bffff	Failure Predicted on drive [StorageVolumeElementName] for array [ComputerSystemElementName]. (Drive 27)	Yes
806f020d-041cffff	Failure Predicted on drive [StorageVolumeElementName] for array [ComputerSystemElementName]. (Drive 28)	Yes
806f020d-041dffff	Failure Predicted on drive [StorageVolumeElementName] for array [ComputerSystemElementName]. (Drive 29)	Yes
806f020d-041effff	Failure Predicted on drive [StorageVolumeElementName] for array [ComputerSystemElementName]. (Drive 30)	Yes

Table 20. Events that automatically notify Support (continued)

Event ID	Message String	Automatically Notify Support
806f020d-041ffff	Failure Predicted on drive [StorageVolumeElementName] for array [ComputerSystemElementName]. (Drive 31)	Yes
806f050c-2001ffff	Memory Logging Limit Reached for [PhysicalMemoryElementName] on Subsystem [MemoryElementName]. (DIMM 1)	Yes
806f050c-2002ffff	Memory Logging Limit Reached for [PhysicalMemoryElementName] on Subsystem [MemoryElementName]. (DIMM 2)	Yes
806f050c-2003ffff	Memory Logging Limit Reached for [PhysicalMemoryElementName] on Subsystem [MemoryElementName]. (DIMM 3)	Yes
806f050c-2004ffff	Memory Logging Limit Reached for [PhysicalMemoryElementName] on Subsystem [MemoryElementName]. (DIMM 4)	Yes
806f050c-2005ffff	Memory Logging Limit Reached for [PhysicalMemoryElementName] on Subsystem [MemoryElementName]. (DIMM 5)	Yes
806f050c-2006ffff	Memory Logging Limit Reached for [PhysicalMemoryElementName] on Subsystem [MemoryElementName]. (DIMM 6)	Yes
806f050c-2007ffff	Memory Logging Limit Reached for [PhysicalMemoryElementName] on Subsystem [MemoryElementName]. (DIMM 7)	Yes
806f050c-2008ffff	Memory Logging Limit Reached for [PhysicalMemoryElementName] on Subsystem [MemoryElementName]. (DIMM 8)	Yes
806f050c-2009ffff	Memory Logging Limit Reached for [PhysicalMemoryElementName] on Subsystem [MemoryElementName]. (DIMM 9)	Yes
806f050c-200affff	Memory Logging Limit Reached for [PhysicalMemoryElementName] on Subsystem [MemoryElementName]. (DIMM 10)	Yes
806f050c-200bffff	Memory Logging Limit Reached for [PhysicalMemoryElementName] on Subsystem [MemoryElementName]. (DIMM 11)	Yes
806f050c-200cffff	Memory Logging Limit Reached for [PhysicalMemoryElementName] on Subsystem [MemoryElementName]. (DIMM 12)	Yes
806f050c-200dffff	Memory Logging Limit Reached for [PhysicalMemoryElementName] on Subsystem [MemoryElementName]. (DIMM 13)	Yes
806f050c-200effff	Memory Logging Limit Reached for [PhysicalMemoryElementName] on Subsystem [MemoryElementName]. (DIMM 14)	Yes

Table 20. Events that automatically notify Support (continued)

Event ID	Message String	Automatically Notify Support
806f050c-200ffff	Memory Logging Limit Reached for [PhysicalMemoryElementName] on Subsystem [MemoryElementName]. (DIMM 15)	Yes
806f050c-2010ffff	Memory Logging Limit Reached for [PhysicalMemoryElementName] on Subsystem [MemoryElementName]. (DIMM 16)	Yes
806f050c-2011ffff	Memory Logging Limit Reached for [PhysicalMemoryElementName] on Subsystem [MemoryElementName]. (DIMM 17)	Yes
806f050c-2012ffff	Memory Logging Limit Reached for [PhysicalMemoryElementName] on Subsystem [MemoryElementName]. (DIMM 18)	Yes
806f050c-2013ffff	Memory Logging Limit Reached for [PhysicalMemoryElementName] on Subsystem [MemoryElementName]. (DIMM 19)	Yes
806f050c-2014ffff	Memory Logging Limit Reached for [PhysicalMemoryElementName] on Subsystem [MemoryElementName]. (DIMM 20)	Yes
806f050c-2015ffff	Memory Logging Limit Reached for [PhysicalMemoryElementName] on Subsystem [MemoryElementName]. (DIMM 21)	Yes
806f050c-2016ffff	Memory Logging Limit Reached for [PhysicalMemoryElementName] on Subsystem [MemoryElementName]. (DIMM 22)	Yes
806f050c-2017ffff	Memory Logging Limit Reached for [PhysicalMemoryElementName] on Subsystem [MemoryElementName]. (DIMM 23)	Yes
806f050c-2018ffff	Memory Logging Limit Reached for [PhysicalMemoryElementName] on Subsystem [MemoryElementName]. (DIMM 24)	Yes
806f050c-2581ffff	Memory Logging Limit Reached for [PhysicalMemoryElementName] on Subsystem [MemoryElementName]. (All DIMMS)	Yes
806f060d-0400ffff	Array [ComputerSystemElementName] has failed. (Drive 0)	Yes
806f060d-0401ffff	Array [ComputerSystemElementName] has failed. (Drive 1)	Yes
806f060d-0402ffff	Array [ComputerSystemElementName] has failed. (Drive 2)	Yes
806f060d-0403ffff	Array [ComputerSystemElementName] has failed. (Drive 3)	Yes
806f060d-0404ffff	Array [ComputerSystemElementName] has failed. (Drive 4)	Yes
806f060d-0405ffff	Array [ComputerSystemElementName] has failed. (Drive 5)	Yes

Table 20. Events that automatically notify Support (continued)

Event ID	Message String	Automatically Notify Support
806f060d-0406ffff	Array [ComputerSystemElementName] has failed. (Drive 6)	Yes
806f060d-0407ffff	Array [ComputerSystemElementName] has failed. (Drive 7)	Yes
806f060d-0408ffff	Array [ComputerSystemElementName] has failed. (Drive 8)	Yes
806f060d-0409ffff	Array [ComputerSystemElementName] has failed. (Drive 9)	Yes
806f060d-040affff	Array [ComputerSystemElementName] has failed. (Drive 10)	Yes
806f060d-040bffff	Array [ComputerSystemElementName] has failed. (Drive 11)	Yes
806f060d-040cffff	Array [ComputerSystemElementName] has failed. (Drive 12)	Yes
806f060d-040dffff	Array [ComputerSystemElementName] has failed. (Drive 13)	Yes
806f060d-040effff	Array [ComputerSystemElementName] has failed. (Drive 14)	Yes
806f060d-040fffff	Array [ComputerSystemElementName] has failed. (Drive 15)	Yes
806f060d-0410ffff	Array [ComputerSystemElementName] has failed. (Drive 16)	Yes
806f060d-0411ffff	Array [ComputerSystemElementName] has failed. (Drive 17)	Yes
806f060d-0412ffff	Array [ComputerSystemElementName] has failed. (Drive 18)	Yes
806f060d-0413ffff	Array [ComputerSystemElementName] has failed. (Drive 19)	Yes
806f060d-0414ffff	Array [ComputerSystemElementName] has failed. (Drive 20)	Yes
806f060d-0415ffff	Array [ComputerSystemElementName] has failed. (Drive 21)	Yes
806f060d-0416ffff	Array [ComputerSystemElementName] has failed. (Drive 22)	Yes
806f060d-0417ffff	Array [ComputerSystemElementName] has failed. (Drive 23)	Yes
806f060d-0418ffff	Array [ComputerSystemElementName] has failed. (Drive 24)	Yes
806f060d-0419ffff	Array [ComputerSystemElementName] has failed. (Drive 25)	Yes
806f060d-041affff	Array [ComputerSystemElementName] has failed. (Drive 26)	Yes

Table 20. Events that automatically notify Support (continued)

Event ID	Message String	Automatically Notify Support
806f060d-041bffff	Array [ComputerSystemElementName] has failed. (Drive 27)	Yes
806f060d-041cffff	Array [ComputerSystemElementName] has failed. (Drive 28)	Yes
806f060d-041dffff	Array [ComputerSystemElementName] has failed. (Drive 29)	Yes
806f060d-041effff	Array [ComputerSystemElementName] has failed. (Drive 30)	Yes
806f060d-041fffff	Array [ComputerSystemElementName] has failed. (Drive 31)	Yes
806f0813-2581ffff	A Uncorrectable Bus Error has occurred on system [ComputerSystemElementName]. (DIMMs)	Yes
806f0813-2582ffff	A Uncorrectable Bus Error has occurred on system [ComputerSystemElementName]. (PCIs)	Yes
806f0813-2584ffff	A Uncorrectable Bus Error has occurred on system [ComputerSystemElementName]. (CPUs)	Yes

## List of IMM events

This section lists all messages that can be sent from the IMM.

- **40000001-00000000 : Management Controller [arg1] Network Initialization Complete.**

This message is for the use case where a Management Controller network has completed initialization.

May also be shown as 4000000100000000 or 0x4000000100000000

**Severity**

Info

**Serviceable**

No

**Automatically notify support**

No

**Alert Category**

System - IMM Network event

**SNMP Trap ID**

37

**CIM Information**

Prefix: IMM ID: 0001

**User Response**

Information only; no action is required.

- **40000002-00000000 : Certificate Authority [arg1] has detected a [arg2] Certificate Error.**

This message is for the use case when there is an error with an SSL Server, SSL Client, or SSL Trusted CA Certificate.

May also be shown as 4000000200000000 or 0x4000000200000000

**Severity**

Error

**Serviceable**

No

**Automatically notify support**

No

**Alert Category**

System - SSL certification

**SNMP Trap ID**

22

**CIM Information**

Prefix: IMM ID: 0002

**User Response**

Make sure that the certificate that you are importing is correct and properly generated.

- **40000003-00000000 : Ethernet Data Rate modified from [arg1] to [arg2] by user [arg3].**

This message is for the use case where a user modifies the Ethernet Port data rate.

May also be shown as 4000000300000000 or 0x4000000300000000

**Severity**

Info

**Serviceable**

No

**Automatically notify support**

No

**Alert Category**

none

**SNMP Trap ID****CIM Information**

Prefix: IMM ID: 0003

**User Response**

Information only; no action is required.

- **40000004-00000000 : Ethernet Duplex setting modified from [arg1] to [arg2] by user [arg3].**

This message is for the use case where A user modifies the Ethernet Port duplex setting.

May also be shown as 4000000400000000 or 0x4000000400000000

**Severity**

Info

**Serviceable**

No

**Automatically notify support**

No

**Alert Category**

none

**SNMP Trap ID**



**CIM Information****Prefix: IMM ID: 0004****User Response**

Information only; no action is required.

- **40000005-00000000 : Ethernet MTU setting modified from [arg1] to [arg2] by user [arg3].**

This message is for the use case where a user modifies the Ethernet Port MTU setting.

May also be shown as 4000000500000000 or 0x4000000500000000

**Severity**

Info

**Serviceable**

No

**Automatically notify support**

No

**Alert Category**

none

**SNMP Trap ID****CIM Information****Prefix: IMM ID: 0005****User Response**

Information only; no action is required.

- **40000006-00000000 : Ethernet locally administered MAC address modified from [arg1] to [arg2] by user [arg3].**

This message is for the use case where a user modifies the Ethernet Port MAC address setting.

May also be shown as 4000000600000000 or 0x4000000600000000

**Severity**

Info

**Serviceable**

No

**Automatically notify support**

No

**Alert Category**

none

**SNMP Trap ID****CIM Information****Prefix: IMM ID: 0006****User Response**

Information only; no action is required.

- **40000007-00000000 : Ethernet interface [arg1] by user [arg2].**

This message is for the use case where a user enables or disabled the ethernet interface.

May also be shown as 4000000700000000 or 0x4000000700000000

**Severity**

Info

**Serviceable**

No

**Automatically notify support**

No

**Alert Category**

none

**SNMP Trap ID**

**CIM Information**

Prefix: IMM ID: 0007

**User Response**

Information only; no action is required.

- **40000008-00000000 : Hostname set to [arg1] by user [arg2].**

This message is for the use case where user modifies the Hostname of a Management Controller.

May also be shown as 4000000800000000 or 0x4000000800000000

**Severity**

Info

**Serviceable**

No

**Automatically notify support**

No

**Alert Category**

System - IMM Network event

**SNMP Trap ID**

37

**CIM Information**

Prefix: IMM ID: 0008

**User Response**

Information only; no action is required.

- **40000009-00000000 : IP address of network interface modified from [arg1] to [arg2] by user [arg3].**

This message is for the use case where user modifies the IP address of a Management Controller.

May also be shown as 4000000900000000 or 0x4000000900000000

**Severity**

Info

**Serviceable**

No

**Automatically notify support**

No

**Alert Category**

System - IMM Network event

**SNMP Trap ID**

37

**CIM Information****Prefix: IMM ID:** 0009**User Response**

Information only; no action is required.

- **4000000a-00000000 : IP subnet mask of network interface modified from [arg1] to [arg2] by user [arg3].**

This message is for the use case where a user modifies the IP subnet mask of a Management Controller.

May also be shown as 4000000a00000000 or 0x4000000a00000000

**Severity**

Info

**Serviceable**

No

**Automatically notify support**

No

**Alert Category**

none

**SNMP Trap ID****CIM Information****Prefix: IMM ID:** 0010**User Response**

Information only; no action is required.

- **4000000b-00000000 : IP address of default gateway modified from [arg1] to [arg2] by user [arg3].**

This message is for the use case where a user modifies the default gateway IP address of a Management Controller.

May also be shown as 4000000b00000000 or 0x4000000b00000000

**Severity**

Info

**Serviceable**

No

**Automatically notify support**

No

**Alert Category**

none

**SNMP Trap ID****CIM Information****Prefix: IMM ID:** 0011**User Response**

Information only; no action is required.

- **4000000c-00000000 : OS Watchdog response [arg1] by [arg2].**

This message is for the use case where an OS Watchdog has been enabled or disabled by a user.

May also be shown as 4000000c00000000 or 0x4000000c00000000

**Severity**

Warning

**Serviceable**

No

**Automatically notify support**

No

**Alert Category**

none

**SNMP Trap ID****CIM Information**

Prefix: IMM ID: 0012

**User Response**

Information only; no action is required.

- **4000000d-00000000 : DHCP[[arg1]] failure, no IP address assigned.**

This message is for the use case where a DHCP server fails to assign an IP address to a Management Controller.

May also be shown as 4000000d00000000 or 0x4000000d00000000

**Severity**

Warning

**Serviceable**

No

**Automatically notify support**

No

**Alert Category**

none

**SNMP Trap ID****CIM Information**

Prefix: IMM ID: 0013

**User Response**

Complete the following steps until the problem is solved:

1. Make sure that the IMM network cable is connected.
  2. Make sure that there is a DHCP server on the network that can assign an IP address to the IMM.
- **4000000e-00000000 : Remote Login Successful. Login ID: [arg1] from [arg2] at IP address [arg3].**

This message is for the use case where a user successfully logs in to a Management Controller.

May also be shown as 4000000e00000000 or 0x4000000e00000000

**Severity**

Info

**Serviceable**

No

**Automatically notify support**

No

**Alert Category**

System - Remote Login

**SNMP Trap ID**

30

**CIM Information****Prefix: IMM ID:** 0014**User Response**

Information only; no action is required.

- **4000000f-00000000 : Attempting to [arg1] server [arg2] by user [arg3].**

This message is for the use case where a user is using the Management Controller to perform a power function on the system.

May also be shown as 4000000f00000000 or 0x4000000f00000000

**Severity**

Info

**Serviceable**

No

**Automatically notify support**

No

**Alert Category**

none

**SNMP Trap ID****CIM Information****Prefix: IMM ID:** 0015**User Response**

Information only; no action is required.

- **40000010-00000000 : Security: Userid: [arg1] had [arg2] login failures from WEB client at IP address [arg3].**

This message is for the use case where a user has failed to log in to a Management Controller from a web browser.

May also be shown as 4000001000000000 or 0x4000001000000000

**Severity**

Warning

**Serviceable**

No

**Automatically notify support**

No

**Alert Category**

System - Remote Login

**SNMP Trap ID**

30

**CIM Information****Prefix: IMM ID:** 0016**User Response**

Complete the following steps until the problem is solved:

1. Make sure that the correct login ID and password are being used.
  2. Have the system administrator reset the login ID or password.
- **40000011-00000000 : Security: Login ID: [arg1] had [arg2] login failures from CLI at [arg3].**

This message is for the use case where a user has failed to log in to a Management Controller from the Legacy CLI.

May also be shown as 4000001100000000 or 0x4000001100000000

**Severity**

Warning

**Serviceable**

No

**Automatically notify support**

No

**Alert Category**

System - Remote Login

**SNMP Trap ID**

30

**CIM Information**

Prefix: IMM ID: 0017

**User Response**

Complete the following steps until the problem is solved:

1. Make sure that the correct login ID and password are being used.
  2. Have the system administrator reset the login ID or password.
- **40000012-00000000 : Remote access attempt failed. Invalid userid or password received. Userid is [arg1] from WEB browser at IP address [arg2].**

This message is for the use case where a remote user has failed to establish a remote control session from a Web browser session.

May also be shown as 4000001200000000 or 0x4000001200000000

**Severity**

Info

**Serviceable**

No

**Automatically notify support**

No

**Alert Category**

System - Remote Login

**SNMP Trap ID**

30

**CIM Information**

Prefix: IMM ID: 0018

**User Response**

Make sure that the correct login ID and password are being used.

- **40000013-00000000 : Remote access attempt failed. Invalid userid or password received. Userid is [arg1] from TELNET client at IP address [arg2].**

This message is for the use case where a user has failed to log in to a Management Controller from a telnet session.

May also be shown as 4000001300000000 or 0x4000001300000000

**Severity**

Info

**Serviceable**

No

**Automatically notify support**

No

**Alert Category**

System - Remote Login

**SNMP Trap ID**

30

**CIM Information**

Prefix: IMM ID: 0019

**User Response**

Make sure that the correct login ID and password are being used.

- **40000014-00000000 : The [arg1] on system [arg2] cleared by user [arg3].**

This message is for the use case where a Management Controller Event Log on a system is cleared by a user.

May also be shown as 4000001400000000 or 0x4000001400000000

**Severity**

Info

**Serviceable**

No

**Automatically notify support**

No

**Alert Category**

none

**SNMP Trap ID**

**CIM Information**

Prefix: IMM ID: 0020

**User Response**

Information only; no action is required.

- **40000015-00000000 : Management Controller [arg1] reset was initiated by user [arg2].**

This message is for the use case where a Management Controller reset is initiated by a user.

May also be shown as 4000001500000000 or 0x4000001500000000

**Severity**

Info

**Serviceable**

No

**Automatically notify support**

No

**Alert Category**

none

**SNMP Trap ID**

**CIM Information**

Prefix: IMM ID: 0021

**User Response**

Information only; no action is required.

- **40000016-00000000 : ENET[[arg1]] DHCP-HSTN=[arg2], DN=[arg3], IP@=[arg4], SN=[arg5], GW@=[arg6], DNS1@=[arg7].**

This message is for the use case where a Management Controller IP address and configuration has been assigned by the DHCP server.

May also be shown as 4000001600000000 or 0x4000001600000000

**Severity**

Info

**Serviceable**

No

**Automatically notify support**

No

**Alert Category**

none

**SNMP Trap ID**

**CIM Information**

Prefix: IMM ID: 0022

**User Response**

Information only; no action is required.

- **40000017-00000000 : ENET[[arg1]] IP-Cfg:HstName=[arg2], IP@=[arg3] ,NetMsk=[arg4], GW@=[arg5].**

This message is for the use case where a Management Controller IP address and configuration has been assigned statically using user data.

May also be shown as 4000001700000000 or 0x4000001700000000

**Severity**

Info

**Serviceable**

No

**Automatically notify support**

No

**Alert Category**

none

**SNMP Trap ID**

**CIM Information**



**Prefix: IMM ID: 0023**

**User Response**

Information only; no action is required.

- **40000018-00000000 : LAN: Ethernet[[arg1]] interface is no longer active.**

This message is for the use case where a Management Controller ethernet interface is no longer active.

May also be shown as 4000001800000000 or 0x4000001800000000

**Severity**

Info

**Serviceable**

No

**Automatically notify support**

No

**Alert Category**

none

**SNMP Trap ID**

**CIM Information**

**Prefix: IMM ID: 0024**

**User Response**

Information only; no action is required.

- **40000019-00000000 : LAN: Ethernet[[arg1]] interface is now active.**

This message is for the use case where a Management Controller ethernet interface is now active.

May also be shown as 4000001900000000 or 0x4000001900000000

**Severity**

Info

**Serviceable**

No

**Automatically notify support**

No

**Alert Category**

none

**SNMP Trap ID**

**CIM Information**

**Prefix: IMM ID: 0025**

**User Response**

Information only; no action is required.

- **4000001a-00000000 : DHCP setting changed to [arg1] by user [arg2].**

This message is for the use case where a user changes the DHCP setting.

May also be shown as 4000001a00000000 or 0x4000001a00000000

**Severity**

Info

**Serviceable**

No

**Automatically notify support**

No

**Alert Category**

none

**SNMP Trap ID**

**CIM Information**

Prefix: IMM ID: 0026

**User Response**

Information only; no action is required.

- **4000001b-00000000 : Management Controller [arg1]: Configuration restored from a file by user [arg2].**

This message is for the use case where a user restores a Management Controller configuration from a file.

May also be shown as 4000001b00000000 or 0x4000001b00000000

**Severity**

Info

**Serviceable**

No

**Automatically notify support**

No

**Alert Category**

none

**SNMP Trap ID**

**CIM Information**

Prefix: IMM ID: 0027

**User Response**

Information only; no action is required.

- **4000001c-00000000 : Watchdog [arg1] Screen Capture Occurred.**

This message is for the use case where an operating system error has occurred and the screen was captured.

May also be shown as 4000001c00000000 or 0x4000001c00000000

**Severity**

Info

**Serviceable**

No

**Automatically notify support**

No

**Alert Category**

System - other

**SNMP Trap ID**

22

**CIM Information**

**Prefix: IMM ID: 0028**

**User Response**

If there was no operating-system error, complete the following steps until the problem is solved:

1. Reconfigure the watchdog timer to a higher value.
2. Make sure that the IMM Ethernet-over-USB interface is enabled.
3. Reinstall the RNDIS or cdc\_ether device driver for the operating system.
4. Disable the watchdog.

If there was an operating-system error, check the integrity of the installed operating system.

- **4000001d-00000000 : Watchdog [arg1] Failed to Capture Screen.**

This message is for the use case where an operating system error has occurred and the screen capture failed.

May also be shown as 4000001d00000000 or 0x4000001d00000000

**Severity**

Error

**Serviceable**

No

**Automatically notify support**

No

**Alert Category**

System - other

**SNMP Trap ID**

22

**CIM Information**

**Prefix: IMM ID: 0029**

**User Response**

Complete the following steps until the problem is solved:

1. Reconfigure the watchdog timer to a higher value.
2. Make sure that the IMM Ethernet over USB interface is enabled.
3. Reinstall the RNDIS or cdc\_ether device driver for the operating system.
4. Disable the watchdog. Check the integrity of the installed operating system.
5. Update the IMM firmware. Important: Some cluster solutions require specific code levels or coordinated code updates. If the device is part of a cluster solution, verify that the latest level of code is supported for the cluster solution before you update the code.

- **4000001e-00000000 : Running the backup Management Controller [arg1] main application.**

This message is for the use case where a Management Controller has resorted to running the backup main application.

May also be shown as 4000001e00000000 or 0x4000001e00000000

**Severity**

Warning

**Serviceable**

No

**Automatically notify support**

No

**Alert Category**

System - other

**SNMP Trap ID**

22

**CIM Information**

Prefix: IMM ID: 0030

**User Response**

Update the IMM firmware. Important: Some cluster solutions require specific code levels or coordinated code updates. If the device is part of a cluster solution, verify that the latest level of code is supported for the cluster solution before you update the code.

- **4000001f-00000000 : Please ensure that the Management Controller [arg1] is flashed with the correct firmware. The Management Controller is unable to match its firmware to the server.**

This message is for the use case where a Management Controller firmware version does not match the server.

May also be shown as 4000001f00000000 or 0x4000001f00000000

**Severity**

Error

**Serviceable**

No

**Automatically notify support**

No

**Alert Category**

System - other

**SNMP Trap ID**

22

**CIM Information**

Prefix: IMM ID: 0031

**User Response**

Update the IMM firmware to a version that the server supports. Important: Some cluster solutions require specific code levels or coordinated code updates. If the device is part of a cluster solution, verify that the latest level of code is supported for the cluster solution before you update the code.

- **40000020-00000000 : Management Controller [arg1] Reset was caused by restoring default values.**

This message is for the use case where a Management Controller has been reset due to a user restoring the configuration to default values.

May also be shown as 4000002000000000 or 0x4000002000000000

**Severity**

Info

**Serviceable**

No

**Automatically notify support**

No

**Alert Category**

none

**SNMP Trap ID**

**CIM Information**

Prefix: IMM ID: 0032

**User Response**

Information only; no action is required.

- **40000021-00000000 : Management Controller [arg1] clock has been set from NTP server [arg2].**

This message is for the use case where a Management Controller clock has been set from the Network Time Protocol server.

May also be shown as 4000002100000000 or 0x4000002100000000

**Severity**

Info

**Serviceable**

No

**Automatically notify support**

No

**Alert Category**

none

**SNMP Trap ID****CIM Information**

Prefix: IMM ID: 0033

**User Response**

Information only; no action is required.

- **40000022-00000000 : SSL data in the Management Controller [arg1] configuration data is invalid. Clearing configuration data region and disabling SSL.**

This message is for the use case where a Management Controller has detected invalid SSL data in the configuration data and is clearing the configuration data region and disabling the SSL.

May also be shown as 4000002200000000 or 0x4000002200000000

**Severity**

Error

**Serviceable**

No

**Automatically notify support**

No

**Alert Category**

System - other

**SNMP Trap ID**

22

**CIM Information**

Prefix: IMM ID: 0034

**User Response**

Complete the following steps until the problem is solved:

1. Make sure that the certificate that you are importing is correct.
  2. Try to import the certificate again.
- **40000023-00000000 : Flash of [arg1] from [arg2] succeeded for user [arg3].**

This message is for the use case where a user has successfully flashed the firmware component (MC Main Application, MC Boot ROM, BIOS, Diagnostics, System Power Backplane, Remote Expansion Enclosure Power Backplane, Integrated System Management Processor, or Remote Expansion Enclosure Processor) from the interface and IP address ( %d).

May also be shown as 4000002300000000 or 0x4000002300000000

**Severity**

Info

**Serviceable**

No

**Automatically notify support**

No

**Alert Category**

none

**SNMP Trap ID**

**CIM Information**

Prefix: IMM ID: 0035

**User Response**

Information only; no action is required.

- **40000024-00000000 : Flash of [arg1] from [arg2] failed for user [arg3].**

This message is for the use case where a user has not flashed the firmware component from the interface and IP address due to a failure.

May also be shown as 4000002400000000 or 0x4000002400000000

**Severity**

Info

**Serviceable**

No

**Automatically notify support**

No

**Alert Category**

System - other

**SNMP Trap ID**

22

**CIM Information**

Prefix: IMM ID: 0036

**User Response**

Information only; no action is required.

- **40000025-00000000 : The [arg1] on system [arg2] is 75% full.**

This message is for the use case where a Management Controller Event Log on a system is 75% full.

May also be shown as 4000002500000000 or 0x4000002500000000

**Severity**

Info

**Serviceable**

No

**Automatically notify support**

No

**Alert Category**

System - Event Log 75% full

**SNMP Trap ID**

35

**CIM Information**

Prefix: IMM ID: 0037

**User Response**

Information only; no action is required.

- **40000026-00000000 : The [arg1] on system [arg2] is 100% full.**

This message is for the use case where a Management Controller Event Log on a system is 100% full.

May also be shown as 4000002600000000 or 0x4000002600000000

**Severity**

Info

**Serviceable**

No

**Automatically notify support**

No

**Alert Category**

System - Event Log Fullness

**SNMP Trap ID**

35

**CIM Information**

Prefix: IMM ID: 0038

**User Response**

To avoid losing older log entries, save the log as a text file and clear the log.

- **40000027-00000000 : Platform Watchdog Timer expired for [arg1].**

This message is for the use case when an implementation has detected a Platform Watchdog Timer Expired

May also be shown as 4000002700000000 or 0x4000002700000000

**Severity**

Error

**Serviceable**

No

**Automatically notify support**

No

**Alert Category**

System - OS Timeout

**SNMP Trap ID**

21

**CIM Information**

Prefix: IMM ID: 0039

**User Response**

Complete the following steps until the problem is solved:

1. Reconfigure the watchdog timer to a higher value.
  2. Make sure that the IMM Ethernet-over-USB interface is enabled.
  3. Reinstall the RNDIS or cdc\_ether device driver for the operating system.
  4. Disable the watchdog.
  5. Check the integrity of the installed operating system.
- **40000028-00000000 : Management Controller Test Alert Generated by [arg1].**

This message is for the use case where a user has generated a Test Alert.

May also be shown as 4000002800000000 or 0x4000002800000000

**Severity**

Info

**Serviceable**

No

**Automatically notify support**

No

**Alert Category**

System - other

**SNMP Trap ID**

22

**CIM Information**

Prefix: IMM ID: 0040

**User Response**

Information only; no action is required.

- **40000029-00000000 : Security: Userid: [arg1] had [arg2] login failures from an SSH client at IP address [arg3].**

This message is for the use case where a user has failed to log in to a Management Controller from SSH.

May also be shown as 4000002900000000 or 0x4000002900000000

**Severity**

Info

**Serviceable**

No

**Automatically notify support**

No

**Alert Category**

System - Remote Login

**SNMP Trap ID**

30

**CIM Information**

Prefix: IMM ID: 0041

**User Response**

Complete the following steps until the problem is solved:

1. Make sure that the correct login ID and password are being used.



2. Have the system administrator reset the login ID or password.
- **4000002a-00000000 : [arg1] firmware mismatch internal to system [arg2]. Please attempt to flash the [arg3] firmware.**

This message is for the use case where a specific type of firmware mismatch has been detected.

May also be shown as 4000002a00000000 or 0x4000002a00000000

**Severity**

Error

**Serviceable**

No

**Automatically notify support**

No

**Alert Category**

System - Other

**SNMP Trap ID**

22

**CIM Information**

Prefix: IMM ID: 0042

**User Response**

Reflash the IMM firmware to the latest version.

- **4000002b-00000000 : Domain name set to [arg1].**

Domain name set by user

May also be shown as 4000002b00000000 or 0x4000002b00000000

**Severity**

Info

**Serviceable**

No

**Automatically notify support**

No

**Alert Category**

none

**SNMP Trap ID**

**CIM Information**

Prefix: IMM ID: 0043

**User Response**

Information only; no action is required.

- **4000002c-00000000 : Domain Source changed to [arg1] by user [arg2].**

Domain source changed by user

May also be shown as 4000002c00000000 or 0x4000002c00000000

**Severity**

Info

**Serviceable**

No

**Automatically notify support**

No

**Alert Category**

none

**SNMP Trap ID**

**CIM Information**

Prefix: IMM ID: 0044

**User Response**

Information only; no action is required.

- **4000002d-00000000 : DDNS setting changed to [arg1] by user [arg2].**

DDNS setting changed by user

May also be shown as 4000002d00000000 or 0x4000002d00000000

**Severity**

Info

**Serviceable**

No

**Automatically notify support**

No

**Alert Category**

none

**SNMP Trap ID**

**CIM Information**

Prefix: IMM ID: 0045

**User Response**

Information only; no action is required.

- **4000002e-00000000 : DDNS registration successful. The domain name is [arg1].**

DDNS registration and values

May also be shown as 4000002e00000000 or 0x4000002e00000000

**Severity**

Info

**Serviceable**

No

**Automatically notify support**

No

**Alert Category**

none

**SNMP Trap ID**

**CIM Information**

Prefix: IMM ID: 0046

**User Response**

Information only; no action is required.

- **4000002f-00000000 : IPv6 enabled by user [arg1].**

IPv6 protocol is enabled by user

May also be shown as 4000002f00000000 or 0x4000002f00000000

**Severity**

Info

**Serviceable**

No

**Automatically notify support**

No

**Alert Category**

none

**SNMP Trap ID**

**CIM Information**

Prefix: IMM ID: 0047

**User Response**

Information only; no action is required.

- **40000030-00000000 : IPv6 disabled by user [arg1].**

IPv6 protocol is disabled by user

May also be shown as 4000003000000000 or 0x4000003000000000

**Severity**

Info

**Serviceable**

No

**Automatically notify support**

No

**Alert Category**

none

**SNMP Trap ID**

**CIM Information**

Prefix: IMM ID: 0048

**User Response**

Information only; no action is required.

- **40000031-00000000 : IPv6 static IP configuration enabled by user [arg1].**

IPv6 static address assignment method is enabled by user

May also be shown as 4000003100000000 or 0x4000003100000000

**Severity**

Info

**Serviceable**

No

**Automatically notify support**

No

**Alert Category**

none

**SNMP Trap ID**

**CIM Information**

Prefix: IMM ID: 0049

**User Response**

Information only; no action is required.

- **40000032-00000000 : IPv6 DHCP enabled by user [arg1].**

IPv6 DHCP assignment method is enabled by user

May also be shown as 4000003200000000 or 0x4000003200000000

**Severity**

Info

**Serviceable**

No

**Automatically notify support**

No

**Alert Category**

none

**SNMP Trap ID**

**CIM Information**

Prefix: IMM ID: 0050

**User Response**

Information only; no action is required.

- **40000033-00000000 : IPv6 stateless auto-configuration enabled by user [arg1].**

IPv6 statless auto-assignment method is enabled by user

May also be shown as 4000003300000000 or 0x4000003300000000

**Severity**

Info

**Serviceable**

No

**Automatically notify support**

No

**Alert Category**

none

**SNMP Trap ID**

**CIM Information**

Prefix: IMM ID: 0051

**User Response**

Information only; no action is required.

- **40000034-00000000 : IPv6 static IP configuration disabled by user [arg1].**

IPv6 static assignment method is disabled by user

May also be shown as 4000003400000000 or 0x4000003400000000

**Severity**

Info

**Serviceable**

No

**Automatically notify support**

No

**Alert Category**

none

**SNMP Trap ID**

**CIM Information**

Prefix: IMM ID: 0052

**User Response**

Information only; no action is required.

- **40000035-00000000 : IPv6 DHCP disabled by user [arg1].**

IPv6 DHCP assignment method is disabled by user

May also be shown as 4000003500000000 or 0x4000003500000000

**Severity**

Info

**Serviceable**

No

**Automatically notify support**

No

**Alert Category**

none

**SNMP Trap ID**

**CIM Information**

Prefix: IMM ID: 0053

**User Response**

Information only; no action is required.

- **40000036-00000000 : IPv6 stateless auto-configuration disabled by user [arg1].**

IPv6 statless auto-assignment method is disabled by user

May also be shown as 4000003600000000 or 0x4000003600000000

**Severity**

Info

**Serviceable**

No

**Automatically notify support**

No

**Alert Category**

none

**SNMP Trap ID****CIM Information**

Prefix: IMM ID: 0054

**User Response**

Information only; no action is required.

- **40000037-00000000 : ENET[[arg1]] IPv6-LinkLocal:HstName=[arg2], IP@[arg3] ,Pref=[arg4].**

IPv6 Link Local address is active

May also be shown as 4000003700000000 or 0x4000003700000000

**Severity**

Info

**Serviceable**

No

**Automatically notify support**

No

**Alert Category**

none

**SNMP Trap ID****CIM Information**

Prefix: IMM ID: 0055

**User Response**

Information only; no action is required.

- **40000038-00000000 : ENET[[arg1]] IPv6-Static:HstName=[arg2], IP@[arg3] ,Pref=[arg4], GW@[arg5].**

IPv6 Static address is active

May also be shown as 4000003800000000 or 0x4000003800000000

**Severity**

Info

**Serviceable**

No

**Automatically notify support**

No

**Alert Category**

none

**SNMP Trap ID****CIM Information**

Prefix: IMM ID: 0056

**User Response**

Information only; no action is required.

- **40000039-00000000 : ENET[[arg1]] DHCPv6-HSTN=[arg2], DN=[arg3], IP@[arg4], Pref=[arg5].**

IPv6 DHCP-assigned address is active

May also be shown as 4000003900000000 or 0x4000003900000000

**Severity**

Info

**Serviceable**

No

**Automatically notify support**

No

**Alert Category**

none

**SNMP Trap ID**

**CIM Information**

Prefix: IMM ID: 0057

**User Response**

Information only; no action is required.

- **4000003a-00000000 : IPv6 static address of network interface modified from [arg1] to [arg2] by user [arg3].**

A user modifies the IPv6 static address of a Management Controller

May also be shown as 4000003a00000000 or 0x4000003a00000000

**Severity**

Info

**Serviceable**

No

**Automatically notify support**

No

**Alert Category**

none

**SNMP Trap ID**

**CIM Information**

Prefix: IMM ID: 0058

**User Response**

Information only; no action is required.

- **4000003b-00000000 : DHCPv6 failure, no IP address assigned.**

S DHCP6 server fails to assign an IP address to a Management Controller.

May also be shown as 4000003b00000000 or 0x4000003b00000000

**Severity**

Warning

**Serviceable**

No

**Automatically notify support**

No

**Alert Category**

none

**SNMP Trap ID****CIM Information**

Prefix: IMM ID: 0059

**User Response**

Complete the following steps until the problem is solved:

1. Make sure that the IMM network cable is connected.
2. Make sure that there is a DHCPv6 server on the network that can assign an IP address to the IMM.

- **4000003c-00000000 : Platform Watchdog Timer expired for [arg1].**

An implementation has detected an OS Loader Watchdog Timer Expired

May also be shown as 4000003c00000000 or 0x4000003c00000000

**Severity**

Error

**Serviceable**

No

**Automatically notify support**

No

**Alert Category**

System - Loader timeout

**SNMP Trap ID**

26

**CIM Information**

Prefix: IMM ID: 0060

**User Response**

1. Reconfigure the watchdog timer to a higher value.
2. Make sure that the IMM Ethernet over USB interface is enabled.
3. Reinstall the RNDIS or cdc\_ether device driver for the operating system.
4. Disable the watchdog.
5. Check the integrity of the installed operating system.

- **4000003d-00000000 : Telnet port number changed from [arg1] to [arg2] by user [arg3].**

A user has modified the telnet port number

May also be shown as 4000003d00000000 or 0x4000003d00000000

**Severity**

Info

**Serviceable**

No

**Automatically notify support**

No

**Alert Category**

none



## SNMP Trap ID

### CIM Information

Prefix: IMM ID: 0061

### User Response

Information only; no action is required.

- **4000003e-00000000 : SSH port number changed from [arg1] to [arg2] by user [arg3].**

A user has modified the SSH port number

May also be shown as 4000003e00000000 or 0x4000003e00000000

### Severity

Info

### Serviceable

No

### Automatically notify support

No

### Alert Category

none

## SNMP Trap ID

### CIM Information

Prefix: IMM ID: 0062

### User Response

Information only; no action is required.

- **4000003f-00000000 : Web-HTTP port number changed from [arg1] to [arg2] by user [arg3].**

A user has modified the Web HTTP port number

May also be shown as 4000003f00000000 or 0x4000003f00000000

### Severity

Info

### Serviceable

No

### Automatically notify support

No

### Alert Category

none

## SNMP Trap ID

### CIM Information

Prefix: IMM ID: 0063

### User Response

Information only; no action is required.

- **40000040-00000000 : Web-HTTPS port number changed from [arg1] to [arg2] by user [arg3].**

A user has modified the Web HTTPS port number

May also be shown as 4000004000000000 or 0x4000004000000000

**Severity**

Info

**Serviceable**

No

**Automatically notify support**

No

**Alert Category**

none

**SNMP Trap ID****CIM Information**

Prefix: IMM ID: 0064

**User Response**

Information only; no action is required.

- **40000041-00000000 : CIM/XML HTTP port number changed from [arg1] to [arg2] by user [arg3].**

A user has modified the CIM HTTP port number

May also be shown as 4000004100000000 or 0x4000004100000000

**Severity**

Info

**Serviceable**

No

**Automatically notify support**

No

**Alert Category**

none

**SNMP Trap ID****CIM Information**

Prefix: IMM ID: 0065

**User Response**

Information only; no action is required.

- **40000042-00000000 : CIM/XML HTTPS port number changed from [arg1] to [arg2] by user [arg3].**

A user has modified the CIM HTTPS port number

May also be shown as 4000004200000000 or 0x4000004200000000

**Severity**

Info

**Serviceable**

No

**Automatically notify support**

No

**Alert Category**

none

**SNMP Trap ID**

**CIM Information**

Prefix: IMM ID: 0066

**User Response**

Information only; no action is required.

- **40000043-00000000 : SNMP Agent port number changed from [arg1] to [arg2] by user [arg3].**

A user has modified the SNMP Agent port number

May also be shown as 4000004300000000 or 0x4000004300000000

**Severity**

Info

**Serviceable**

No

**Automatically notify support**

No

**Alert Category**

none

**SNMP Trap ID****CIM Information**

Prefix: IMM ID: 0067

**User Response**

Information only; no action is required.

- **40000044-00000000 : SNMP Traps port number changed from [arg1] to [arg2] by user [arg3].**

A user has modified the SNMP Traps port number

May also be shown as 4000004400000000 or 0x4000004400000000

**Severity**

Info

**Serviceable**

No

**Automatically notify support**

No

**Alert Category**

none

**SNMP Trap ID****CIM Information**

Prefix: IMM ID: 0068

**User Response**

Information only; no action is required.

- **40000045-00000000 : Syslog port number changed from [arg1] to [arg2] by user [arg3].**

A user has modified the Syslog receiver port number

May also be shown as 4000004500000000 or 0x4000004500000000

**Severity**

Info

**Serviceable**

No

**Automatically notify support**

No

**Alert Category**

none

**SNMP Trap ID****CIM Information**

Prefix: IMM ID: 0069

**User Response**

Information only; no action is required.

- **40000046-00000000 : Remote Presence port number changed from [arg1] to [arg2] by user [arg3].**

A user has modified the Remote Presence port number

May also be shown as 4000004600000000 or 0x4000004600000000

**Severity**

Info

**Serviceable**

No

**Automatically notify support**

No

**Alert Category**

none

**SNMP Trap ID****CIM Information**

Prefix: IMM ID: 0070

**User Response**

Information only; no action is required.

- **40000047-00000000 : LED [arg1] state changed to [arg2] by [arg3].**

A user has modified the state of an LED

May also be shown as 4000004700000000 or 0x4000004700000000

**Severity**

Info

**Serviceable**

No

**Automatically notify support**

No

**Alert Category**

none

**SNMP Trap ID****CIM Information**

Prefix: IMM ID: 0071

**User Response**

Information only; no action is required.

- **40000048-00000000 : Inventory data changed for device [arg1], new device data hash=[arg2], new master data hash=[arg3].**

Something has caused the physical inventory to change

May also be shown as 4000004800000000 or 0x4000004800000000

**Severity**

Info

**Serviceable**

No

**Automatically notify support**

No

**Alert Category**

none

**SNMP Trap ID****CIM Information**

Prefix: IMM ID: 0072

**User Response**

Information only; no action is required.

- **40000049-00000000 : SNMP [arg1] enabled by user [arg2].**

A user enabled SNMPv1 or SNMPv3 or Traps

May also be shown as 4000004900000000 or 0x4000004900000000

**Severity**

Info

**Serviceable**

No

**Automatically notify support**

No

**Alert Category**

none

**SNMP Trap ID****CIM Information**

Prefix: IMM ID: 0073

**User Response**

Information only; no action is required.

- **4000004a-00000000 : SNMP [arg1] disabled by user [arg2].**

A user disabled SNMPv1 or SNMPv3 or Traps

May also be shown as 4000004a00000000 or 0x4000004a00000000

**Severity**

Info

**Serviceable**

No

**Automatically notify support**

No

**Alert Category**

none

**SNMP Trap ID**

**CIM Information**

Prefix: IMM ID: 0074

**User Response**

Information only; no action is required.

- **4000004b-00000000 : SNMPv1 [arg1] set by user [arg2]: Name=[arg3], AccessType=[arg4], Address=[arg5].**

A user changed the SNMP community string

May also be shown as 4000004b00000000 or 0x4000004b00000000

**Severity**

Info

**Serviceable**

No

**Automatically notify support**

No

**Alert Category**

none

**SNMP Trap ID**

**CIM Information**

Prefix: IMM ID: 0075

**User Response**

Information only; no action is required.

- **4000004c-00000000 : LDAP Server configuration set by user [arg1]: SelectionMethod=[arg2], DomainName=[arg3], Server1=[arg4], Server2=[arg5], Server3=[arg6], Server4=[arg7].**

A user changed the LDAP server configuration

May also be shown as 4000004c00000000 or 0x4000004c00000000

**Severity**

Info

**Serviceable**

No

**Automatically notify support**

No

**Alert Category**

none

**SNMP Trap ID**

**CIM Information**

**Prefix: IMM ID: 0076**

**User Response**

Information only; no action is required.

- **4000004d-00000000 : LDAP set by user [arg1]: RootDN=[arg2], UIDSearchAttribute=[arg3], BindingMethod=[arg4], EnhancedRBS=[arg5], TargetName=[arg6], GroupFilter=[arg7], GroupAttribute=[arg8], LoginAttribute=[arg9].**

A user configured an LDAP Miscellaneous setting

May also be shown as 4000004d00000000 or 0x4000004d00000000

**Severity**

Info

**Serviceable**

No

**Automatically notify support**

No

**Alert Category**

none

**SNMP Trap ID**

**CIM Information**

**Prefix: IMM ID: 0077**

**User Response**

Information only; no action is required.

- **4000004e-00000000 : Serial Redirection set by user [arg1]: Mode=[arg2], BaudRate=[arg3], StopBits=[arg4], Parity=[arg5], SessionTerminateSequence=[arg6].**

A user configured the Serial Port mode

May also be shown as 4000004e00000000 or 0x4000004e00000000

**Severity**

Info

**Serviceable**

No

**Automatically notify support**

No

**Alert Category**

none

**SNMP Trap ID**

**CIM Information**

**Prefix: IMM ID: 0078**

**User Response**

Information only; no action is required.

- **4000004f-00000000 : Date and Time set by user [arg1]: Date=[arg2], Time=[arg3], DST Auto-adjust=[arg4], Timezone=[arg5].**

A user configured the Date and Time settings

May also be shown as 4000004f00000000 or 0x4000004f00000000

**Severity**

Info

**Serviceable**

No

**Automatically notify support**

No

**Alert Category**

none

**SNMP Trap ID****CIM Information**

Prefix: IMM ID: 0079

**User Response**

Information only; no action is required.

- **40000050-00000000 : Server General Settings set by user [arg1]: Name=[arg2], Contact=[arg3], Location=[arg4], Room=[arg5], RackID=[arg6], Rack U-position=[arg7].**

A user configured the Location setting

May also be shown as 4000005000000000 or 0x4000005000000000

**Severity**

Info

**Serviceable**

No

**Automatically notify support**

No

**Alert Category**

none

**SNMP Trap ID****CIM Information**

Prefix: IMM ID: 0080

**User Response**

Information only; no action is required.

- **40000051-00000000 : Server Power Off Delay set to [arg1] by user [arg2].**

A user configured the Server Power Off Delay

May also be shown as 4000005100000000 or 0x4000005100000000

**Severity**

Info

**Serviceable**

No

**Automatically notify support**

No

**Alert Category**

none



## SNMP Trap ID

### CIM Information

Prefix: IMM ID: 0081

### User Response

Information only; no action is required.

- **40000052-00000000 : Server [arg1] scheduled for [arg2] at [arg3] by user [arg4].**

A user configured a Server Power action at a specific time

May also be shown as 4000005200000000 or 0x4000005200000000

### Severity

Info

### Serviceable

No

### Automatically notify support

No

### Alert Category

none

## SNMP Trap ID

### CIM Information

Prefix: IMM ID: 0082

### User Response

Information only; no action is required.

- **40000053-00000000 : Server [arg1] scheduled for every [arg2] at [arg3] by user [arg4].**

A user configured a recurring Server Power Action

May also be shown as 4000005300000000 or 0x4000005300000000

### Severity

Info

### Serviceable

No

### Automatically notify support

No

### Alert Category

none

## SNMP Trap ID

### CIM Information

Prefix: IMM ID: 0083

### User Response

Information only; no action is required.

- **40000054-00000000 : Server [arg1] [arg2] cleared by user [arg3].**

A user cleared a Server Power Action.

May also be shown as 4000005400000000 or 0x4000005400000000

**Severity**

Info

**Serviceable**

No

**Automatically notify support**

No

**Alert Category**

none

**SNMP Trap ID****CIM Information**

Prefix: IMM ID: 0084

**User Response**

Information only; no action is required.

- **40000055-00000000 : Synchronize time setting by user [arg1]: Mode=[arg2], NTPServerHost1=[arg3]:[arg4],NTPServerHost2=[arg5]:[arg6],NTPServerHost3=[arg7]:[arg8],NTPServerHost4=[arg9]:[arg10],NTPUpdateFrequency=[arg11].**

A user configured the Date and Time synchronize settings

May also be shown as 4000005500000000 or 0x4000005500000000

**Severity**

Info

**Serviceable**

No

**Automatically notify support**

No

**Alert Category**

none

**SNMP Trap ID****CIM Information**

Prefix: IMM ID: 0085

**User Response**

Information only; no action is required.

- **40000056-00000000 : SMTP Server set by user [arg1] to [arg2]:[arg3].**

A user configured the SMTP server

May also be shown as 4000005600000000 or 0x4000005600000000

**Severity**

Info

**Serviceable**

No

**Automatically notify support**

No

**Alert Category**

none

## SNMP Trap ID

### CIM Information

Prefix: IMM ID: 0086

### User Response

Information only; no action is required.

- **40000057-00000000 : Telnet [arg1] by user [arg2].**

A user enables or disables Telnet services

May also be shown as 4000005700000000 or 0x4000005700000000

### Severity

Info

### Serviceable

No

### Automatically notify support

No

### Alert Category

none

## SNMP Trap ID

### CIM Information

Prefix: IMM ID: 0087

### User Response

Information only; no action is required.

- **40000058-00000000 : DNS servers set by user [arg1]: UseAdditionalServers=[arg2], PreferredDNStype=[arg3], IPv4Server1=[arg4], IPv4Server2=[arg5], IPv4Server3=[arg6], IPv6Server1=[arg7], IPv6Server2=[arg8], IPv6Server3=[arg9].**

A user configures the DNS servers

May also be shown as 4000005800000000 or 0x4000005800000000

### Severity

Info

### Serviceable

No

### Automatically notify support

No

### Alert Category

none

## SNMP Trap ID

### CIM Information

Prefix: IMM ID: 0088

### User Response

Information only; no action is required.

- **40000059-00000000 : LAN over USB [arg1] by user [arg2].**

A user configured USB-LAN

May also be shown as 4000005900000000 or 0x4000005900000000

**Severity**

Info

**Serviceable**

No

**Automatically notify support**

No

**Alert Category**

none

**SNMP Trap ID**

**CIM Information**

Prefix: IMM ID: 0089

**User Response**

Information only; no action is required.

- **4000005a-00000000 : LAN over USB Port Forwarding set by user [arg1]: ExternalPort=[arg2], USB-LAN port=[arg3].**

A user configured USB-LAN port forwarding

May also be shown as 4000005a00000000 or 0x4000005a00000000

**Severity**

Info

**Serviceable**

No

**Automatically notify support**

No

**Alert Category**

none

**SNMP Trap ID**

**CIM Information**

Prefix: IMM ID: 0090

**User Response**

Information only; no action is required.

- **4000005b-00000000 : Secure Web services (HTTPS) [arg1] by user [arg2].**

A user enables or disables Secure web services

May also be shown as 4000005b00000000 or 0x4000005b00000000

**Severity**

Info

**Serviceable**

No

**Automatically notify support**

No

**Alert Category**

none

**SNMP Trap ID**

**CIM Information**

**Prefix: IMM ID:** 0091

**User Response**

Information only; no action is required.

- **4000005c-00000000 : Secure CIM/XML(HTTPS) [arg1] by user [arg2].**

A user enables or disables Secure CIM/XML services

May also be shown as 4000005c00000000 or 0x4000005c00000000

**Severity**

Info

**Serviceable**

No

**Automatically notify support**

No

**Alert Category**

none

**SNMP Trap ID**

**CIM Information**

**Prefix: IMM ID:** 0092

**User Response**

Information only; no action is required.

- **4000005d-00000000 : Secure LDAP [arg1] by user [arg2].**

A user enables or disables Secure LDAP services

May also be shown as 4000005d00000000 or 0x4000005d00000000

**Severity**

Info

**Serviceable**

No

**Automatically notify support**

No

**Alert Category**

none

**SNMP Trap ID**

**CIM Information**

**Prefix: IMM ID:** 0093

**User Response**

Information only; no action is required.

- **4000005e-00000000 : SSH [arg1] by user [arg2].**

A user enables or disables SSH services

May also be shown as 4000005e00000000 or 0x4000005e00000000

**Severity**

Info

**Serviceable**

No

**Automatically notify support**

No

**Alert Category**

none

**SNMP Trap ID**

**CIM Information**

Prefix: IMM ID: 0094

**User Response**

Information only; no action is required.

- **4000005f-00000000 : Server timeouts set by user [arg1]: EnableOSWatchdog=[arg2], OSWatchdogTimeout=[arg3], EnableLoaderWatchdog=[arg4], LoaderTimeout=[arg5].**

A user configures Server Timeouts

May also be shown as 4000005f00000000 or 0x4000005f00000000

**Severity**

Info

**Serviceable**

No

**Automatically notify support**

No

**Alert Category**

none

**SNMP Trap ID**

**CIM Information**

Prefix: IMM ID: 0095

**User Response**

Information only; no action is required.

- **40000060-00000000 : License key for [arg1] added by user [arg2].**

A user installs License Key

May also be shown as 4000006000000000 or 0x4000006000000000

**Severity**

Info

**Serviceable**

No

**Automatically notify support**

No

**Alert Category**

none

#### **SNMP Trap ID**

#### **CIM Information**

**Prefix: IMM ID:** 0096

#### **User Response**

Information only; no action is required.

- **40000061-00000000 : License key for [arg1] removed by user [arg2].**

A user removes a License Key

May also be shown as 4000006100000000 or 0x4000006100000000

#### **Severity**

Info

#### **Serviceable**

No

#### **Automatically notify support**

No

#### **Alert Category**

none

#### **SNMP Trap ID**

#### **CIM Information**

**Prefix: IMM ID:** 0097

#### **User Response**

Information only; no action is required.

- **40000062-00000000 : Global Login General Settings set by user [arg1]: AuthenticationMethod=[arg2], LockoutPeriod=[arg3], SessionTimeout=[arg4].**

A user changes the Global Login General Settings

May also be shown as 4000006200000000 or 0x4000006200000000

#### **Severity**

Info

#### **Serviceable**

No

#### **Automatically notify support**

No

#### **Alert Category**

none

#### **SNMP Trap ID**

#### **CIM Information**

**Prefix: IMM ID:** 0098

#### **User Response**

Information only; no action is required.

- **40000063-00000000 : Global Login Account Security set by user [arg1]: PasswordRequired=[arg2], PasswordExpirationPeriod=[arg3], MinimumPasswordReuseCycle=[arg4],**

**MinimumPasswordLength=[arg5], MinimumPasswordChangeInterval=[arg6],  
MaximumLoginFailures=[arg7], LockoutAfterMaxFailures=[arg8], MinimumDifferentCharacters=[arg9], DefaultIDExpired=[arg10], ChangePasswordFirstAccess=[arg11].**

A user changes the Global Login Account Security Settings to Legacy

May also be shown as 4000006300000000 or 0x4000006300000000

**Severity**

Info

**Serviceable**

No

**Automatically notify support**

No

**Alert Category**

none

**SNMP Trap ID**

**CIM Information**

Prefix: IMM ID: 0099

**User Response**

Information only; no action is required.

- **40000064-00000000 : User [arg1] created.**

A user account was created

May also be shown as 4000006400000000 or 0x4000006400000000

**Severity**

Info

**Serviceable**

No

**Automatically notify support**

No

**Alert Category**

none

**SNMP Trap ID**

**CIM Information**

Prefix: IMM ID: 0100

**User Response**

Information only; no action is required.

- **40000065-00000000 : User [arg1] removed.**

A user account was deleted

May also be shown as 4000006500000000 or 0x4000006500000000

**Severity**

Info

**Serviceable**

No



**Automatically notify support**

No

**Alert Category**

none

**SNMP Trap ID**

**CIM Information**

Prefix: IMM ID: 0101

**User Response**

Information only; no action is required.

- **40000066-00000000 : User [arg1] password modified.**

A user account was changed

May also be shown as 4000006600000000 or 0x4000006600000000

**Severity**

Info

**Serviceable**

No

**Automatically notify support**

No

**Alert Category**

none

**SNMP Trap ID**

**CIM Information**

Prefix: IMM ID: 0102

**User Response**

Information only; no action is required.

- **40000067-00000000 : User [arg1] role set to [arg2].**

A user account role assigned

May also be shown as 4000006700000000 or 0x4000006700000000

**Severity**

Info

**Serviceable**

No

**Automatically notify support**

No

**Alert Category**

none

**SNMP Trap ID**

**CIM Information**

Prefix: IMM ID: 0103

**User Response**

Information only; no action is required.

- **40000068-00000000 : User [arg1] custom privileges set: [arg2].**

User account privileges assigned

May also be shown as 4000006800000000 or 0x4000006800000000

**Severity**

Info

**Serviceable**

No

**Automatically notify support**

No

**Alert Category**

none

**SNMP Trap ID**

**CIM Information**

Prefix: IMM ID: 0104

**User Response**

Information only; no action is required.

- **40000069-00000000 : User [arg1] for SNMPv3 set: AuthenticationProtocol=[arg2], PrivacyProtocol=[arg3], AccessType=[arg4], HostforTraps=[arg5].**

User account SNMPv3 settings changed

May also be shown as 4000006900000000 or 0x4000006900000000

**Severity**

Info

**Serviceable**

No

**Automatically notify support**

No

**Alert Category**

none

**SNMP Trap ID**

**CIM Information**

Prefix: IMM ID: 0105

**User Response**

Information only; no action is required.

- **4000006a-00000000 : SSH Client key added for user [arg1].**

User locally defined an SSH Client key

May also be shown as 4000006a00000000 or 0x4000006a00000000

**Severity**

Info

**Serviceable**

No

**Automatically notify support**

No

**Alert Category**

none

**SNMP Trap ID**

**CIM Information**

Prefix: IMM ID: 0106

**User Response**

Information only; no action is required.

- **4000006b-00000000 : SSH Client key imported for user [arg1] from [arg2].**

User imported an SSH Client key

May also be shown as 4000006b00000000 or 0x4000006b00000000

**Severity**

Info

**Serviceable**

No

**Automatically notify support**

No

**Alert Category**

none

**SNMP Trap ID**

**CIM Information**

Prefix: IMM ID: 0107

**User Response**

Information only; no action is required.

- **4000006c-00000000 : SSH Client key removed from user [arg1].**

User removed an SSH Client key

May also be shown as 4000006c00000000 or 0x4000006c00000000

**Severity**

Info

**Serviceable**

No

**Automatically notify support**

No

**Alert Category**

none

**SNMP Trap ID**

**CIM Information**

Prefix: IMM ID: 0108

**User Response**

Information only; no action is required.

- **4000006d-00000000 : Management Controller [arg1]: Configuration saved to a file by user [arg2].**

A user saves a Management Controller configuration to a file.

May also be shown as 4000006d00000000 or 0x4000006d00000000

**Severity**

Info

**Serviceable**

No

**Automatically notify support**

No

**Alert Category**

none

**SNMP Trap ID**

**CIM Information**

Prefix: IMM ID: 0109

**User Response**

Information only; no action is required.

- **4000006e-00000000 : Alert Configuration Global Event Notification set by user [arg1]: RetryLimit=[arg2], RetryInterval=[arg3], EntryInterval=[arg4].**

A user changes the Global Event Notification settings.

May also be shown as 4000006e00000000 or 0x4000006e00000000

**Severity**

Info

**Serviceable**

No

**Automatically notify support**

No

**Alert Category**

none

**SNMP Trap ID**

**CIM Information**

Prefix: IMM ID: 0110

**User Response**

Information only; no action is required.

- **4000006f-00000000 : Alert Recipient Number [arg1] updated: Name=[arg2], DeliveryMethod=[arg3], Address=[arg4], IncludeLog=[arg5], Enabled=[arg6], EnabledAlerts=[arg7], AllowedFilters=[arg8].**

A user adds or updates an Alert Recipient

May also be shown as 4000006f00000000 or 0x4000006f00000000

**Severity**

Info

**Serviceable**

No

**Automatically notify support**

No

**Alert Category**

none

**SNMP Trap ID**

**CIM Information**

**Prefix: IMM ID:** 0111

**User Response**

Information only; no action is required.

- **40000070-00000000 : SNMP Traps enabled by user [arg1]: EnabledAlerts=[arg2], AllowedFilters=[arg3].**

A user enabled the SNMP Traps configuration

May also be shown as 4000007000000000 or 0x4000007000000000

**Severity**

Info

**Serviceable**

No

**Automatically notify support**

No

**Alert Category**

none

**SNMP Trap ID**

**CIM Information**

**Prefix: IMM ID:** 0112

**User Response**

Information only; no action is required.

- **40000071-00000000 : The power cap value changed from [arg1] watts to [arg2] watts by user [arg3].**

Power Cap values changed by user

May also be shown as 4000007100000000 or 0x4000007100000000

**Severity**

Info

**Serviceable**

No

**Automatically notify support**

No

**Alert Category**

none

**SNMP Trap ID**

**CIM Information**

**Prefix: IMM ID: 0113**

**User Response**

Information only; no action is required.

- **40000072-00000000 : The minimum power cap value changed from [arg1] watts to [arg2] watts.**

Minimum Power Cap value changed

May also be shown as 4000007200000000 or 0x4000007200000000

**Severity**

Info

**Serviceable**

No

**Automatically notify support**

No

**Alert Category**

none

**SNMP Trap ID**

**CIM Information**

**Prefix: IMM ID: 0114**

**User Response**

Information only; no action is required.

- **40000073-00000000 : The maximum power cap value changed from [arg1] watts to [arg2] watts.**

Maximum Power Cap value changed

May also be shown as 4000007300000000 or 0x4000007300000000

**Severity**

Info

**Serviceable**

No

**Automatically notify support**

No

**Alert Category**

none

**SNMP Trap ID**

**CIM Information**

**Prefix: IMM ID: 0115**

**User Response**

Information only; no action is required.

- **40000074-00000000 : The soft minimum power cap value changed from [arg1] watts to [arg2] watts.**

Soft Minimum Power Cap value changed

May also be shown as 4000007400000000 or 0x4000007400000000

**Severity**

Info

**Serviceable**

No

**Automatically notify support**

No

**Alert Category**

none

**SNMP Trap ID****CIM Information**

Prefix: IMM ID: 0116

**User Response**

Information only; no action is required.

- **40000075-00000000 : The measured power value exceeded the power cap value.**

Power exceeded cap

May also be shown as 4000007500000000 or 0x4000007500000000

**Severity**

Warning

**Serviceable**

No

**Automatically notify support**

No

**Alert Category**

Warning - Power

**SNMP Trap ID**

164

**CIM Information**

Prefix: IMM ID: 0117

**User Response**

Information only; no action is required.

- **40000076-00000000 : The new minimum power cap value exceeded the power cap value.**

Minimum Power Cap exceeds Power Cap

May also be shown as 4000007600000000 or 0x4000007600000000

**Severity**

Warning

**Serviceable**

No

**Automatically notify support**

No

**Alert Category**

Warning - Power

**SNMP Trap ID**

164

**CIM Information**

Prefix: IMM ID: 0118

**User Response**

Information only; no action is required.

- **40000077-00000000 : Power capping was activated by user [arg1].**

Power capping activated by user

May also be shown as 4000007700000000 or 0x4000007700000000

**Severity**

Info

**Serviceable**

No

**Automatically notify support**

No

**Alert Category**

none

**SNMP Trap ID****CIM Information**

Prefix: IMM ID: 0119

**User Response**

Information only; no action is required.

- **40000078-00000000 : Power capping was deactivated by user [arg1].**

Power capping deactivated by user

May also be shown as 4000007800000000 or 0x4000007800000000

**Severity**

Info

**Serviceable**

No

**Automatically notify support**

No

**Alert Category**

none

**SNMP Trap ID****CIM Information**

Prefix: IMM ID: 0120

**User Response**

Information only; no action is required.

- **40000079-00000000 : Static Power Savings mode has been turned on by user [arg1].**

Static Power Savings mode turned on by user

May also be shown as 4000007900000000 or 0x4000007900000000

**Severity**

Info

**Serviceable**

No



**Automatically notify support**

No

**Alert Category**

none

**SNMP Trap ID**

**CIM Information**

Prefix: IMM ID: 0121

**User Response**

Information only; no action is required.

- **4000007a-00000000 : Static Power Savings mode has been turned off by user [arg1].**

Static Power Savings mode turned off by user

May also be shown as 4000007a00000000 or 0x4000007a00000000

**Severity**

Info

**Serviceable**

No

**Automatically notify support**

No

**Alert Category**

none

**SNMP Trap ID**

**CIM Information**

Prefix: IMM ID: 0122

**User Response**

Information only; no action is required.

- **4000007b-00000000 : Dynamic Power Savings mode has been turned on by user [arg1].**

Dynamic Power Savings mode turned on by user

May also be shown as 4000007b00000000 or 0x4000007b00000000

**Severity**

Info

**Serviceable**

No

**Automatically notify support**

No

**Alert Category**

none

**SNMP Trap ID**

**CIM Information**

Prefix: IMM ID: 0123

**User Response**

Information only; no action is required.

- **4000007c-00000000 : Dynamic Power Savings mode has been turned off by user [arg1].**

Dynamic Power Savings mode turned off by user

May also be shown as 4000007c00000000 or 0x4000007c00000000

**Severity**

Info

**Serviceable**

No

**Automatically notify support**

No

**Alert Category**

none

**SNMP Trap ID**

**CIM Information**

Prefix: IMM ID: 0124

**User Response**

Information only; no action is required.

- **4000007d-00000000 : Power cap and external throttling occurred.**

Power cap and external throttling occurred

May also be shown as 4000007d00000000 or 0x4000007d00000000

**Severity**

Info

**Serviceable**

No

**Automatically notify support**

No

**Alert Category**

none

**SNMP Trap ID**

**CIM Information**

Prefix: IMM ID: 0125

**User Response**

Information only; no action is required.

- **4000007e-00000000 : External throttling occurred.**

External throttling occurred

May also be shown as 4000007e00000000 or 0x4000007e00000000

**Severity**

Info

**Serviceable**

No

**Automatically notify support**

No

**Alert Category**

none

**SNMP Trap ID**

**CIM Information**

Prefix: IMM ID: 0126

**User Response**

Information only; no action is required.

- **4000007f-00000000 : Power cap throttling occurred.**

Power cap throttling occurred

May also be shown as 4000007f00000000 or 0x4000007f00000000

**Severity**

Info

**Serviceable**

No

**Automatically notify support**

No

**Alert Category**

none

**SNMP Trap ID**

**CIM Information**

Prefix: IMM ID: 0127

**User Response**

Information only; no action is required.

- **40000080-00000000 : Remote Control session started by user [arg1] in [arg2] mode.**

Remote Control session started

May also be shown as 4000008000000000 or 0x4000008000000000

**Severity**

Info

**Serviceable**

No

**Automatically notify support**

No

**Alert Category**

none

**SNMP Trap ID**

**CIM Information**

Prefix: IMM ID: 0128

**User Response**

Information only; no action is required.

- **40000081-00000000 : PXE boot requested by user [arg1].**

PXE boot requested

May also be shown as 4000008100000000 or 0x4000008100000000

**Severity**

Info

**Serviceable**

No

**Automatically notify support**

No

**Alert Category**

none

**SNMP Trap ID**

**CIM Information**

Prefix: IMM ID: 0129

**User Response**

Information only; no action is required.

- **40000082-00000000 : The measured power value has returned below the power cap value.**

Power exceeded cap recovered

May also be shown as 4000008200000000 or 0x4000008200000000

**Severity**

Info

**Serviceable**

No

**Automatically notify support**

No

**Alert Category**

Warning - Power

**SNMP Trap ID**

164

**CIM Information**

Prefix: IMM ID: 0130

**User Response**

Information only; no action is required.

- **40000083-00000000 : The new minimum power cap value has returned below the power cap value.**

Minimum Power Cap exceeds Power Cap recovered

May also be shown as 4000008300000000 or 0x4000008300000000

**Severity**

Info

**Serviceable**

No

**Automatically notify support**

No

**Alert Category**

Warning - Power

**SNMP Trap ID**

164

**CIM Information**

Prefix: IMM ID: 0131

**User Response**

Information only; no action is required.

- **40000084-00000000 : IMM firmware mismatch between nodes [arg1] and [arg2]. Please attempt to flash the IMM firmware to the same level on all nodes.**

A mismatch of IMM firmware has been detected between nodes

May also be shown as 4000008400000000 or 0x4000008400000000

**Severity**

Error

**Serviceable**

No

**Automatically notify support**

No

**Alert Category**

System - Other

**SNMP Trap ID**

22

**CIM Information**

Prefix: IMM ID: 0132

**User Response**

Attempt to flash the IMM firmware to the same level on all nodes.

- **40000085-00000000 : FPGA firmware mismatch between nodes [arg1] and [arg2]. Please attempt to flash the FPGA firmware to the same level on all nodes.**

A mismatch of FPGA firmware has been detected between nodes

May also be shown as 4000008500000000 or 0x4000008500000000

**Severity**

Error

**Serviceable**

No

**Automatically notify support**

No

**Alert Category**

System - Other

**SNMP Trap ID**

22

**CIM Information**

Prefix: IMM ID: 0133

**User Response**

Attempt to flash the FPGA firmware to the same level on all nodes.

- **40000086-00000000 : Test Call Home Generated by user [arg1].**

Test Call Home generated by user.

May also be shown as 4000008600000000 or 0x4000008600000000

**Severity**

Info

**Serviceable**

No

**Automatically notify support**

Yes

**Alert Category**

none

**SNMP Trap ID**

**CIM Information**

Prefix: IMM ID: 0134

**User Response**

Information only; no action is required.

- **40000087-00000000 : Manual Call Home by user [arg1]: [arg2].**

Manual Call Home by user.

May also be shown as 4000008700000000 or 0x4000008700000000

**Severity**

Info

**Serviceable**

No

**Automatically notify support**

Yes

**Alert Category**

none

**SNMP Trap ID**

**CIM Information**

Prefix: IMM ID: 0135

**User Response**

Lenovo Support will address the problem.

- **40000088-00000000 : Management Controller [arg1]: Configuration restoration from a file by user [arg2] completed.**

This message is for the use case where a user restores a Management Controller configuration from a file and it completes.

May also be shown as 4000008800000000 or 0x4000008800000000

**Severity**

Info

**Serviceable**

No

**Automatically notify support**

No

**Alert Category**

none

**SNMP Trap ID****CIM Information**

Prefix: IMM ID: 0136

**User Response**

Information only; no action is required.

- **4000089-00000000 : Management Controller [arg1]: Configuration restoration from a file by user [arg2] failed to complete.**

This message is for the use case where a user restores a Management Controller configuration from a file and the restoration fails to complete.

May also be shown as 4000089000000000 or 0x4000089000000000

**Severity**

Error

**Serviceable**

No

**Automatically notify support**

No

**Alert Category**

System - Other

**SNMP Trap ID**

22

**CIM Information**

Prefix: IMM ID: 0137

**User Response**

1. Turn off the server and disconnect it from the power source. You must disconnect the server from ac power to reset the IMM.
2. After 45 seconds, reconnect the server to the power source and turn on the server.
3. Retry the operation.

- **400008a-00000000 : Management Controller [arg1]: Configuration restoration from a file by user [arg2] failed to start.**

This message is for the use case where a user restores a Management Controller configuration from a file and the restoration fails to start.

May also be shown as 400008a000000000 or 0x400008a000000000

**Severity**

Error

**Serviceable**

No

**Automatically notify support**

No

**Alert Category**

System - Other

**SNMP Trap ID**

22

**CIM Information**

**Prefix: IMM ID: 0138**

**User Response**

1. Turn off the server and disconnect it from the power source. You must disconnect the server from ac power to reset the IMM.
2. After 45 seconds, reconnect the server to the power source and turn on the server.
3. Retry the operation.

- **4000008b-00000000 : Storage [arg1] has changed.**

This message is for the use case where an IP address for the Storage Management has changed

May also be shown as 4000008b00000000 or 0x4000008b00000000

**Severity**

Info

**Serviceable**

No

**Automatically notify support**

No

**Alert Category**

System - IMM Network event

**SNMP Trap ID**

37

**CIM Information**

**Prefix: IMM ID: 0139**

**User Response**

Information only; no action is required.

- **4000008c-00000000 : Security: Userid: [arg1] had [arg2] login failures from a CIM client at IP address [arg3].**

This message is for the use case where a user has failed to log in to a Management Controller from CIM.

May also be shown as 4000008c00000000 or 0x4000008c00000000

**Severity**

Info

**Serviceable**

No

**Automatically notify support**

No

**Alert Category**

System - Remote Login

**SNMP Trap ID**

30

**CIM Information**

**Prefix: IMM ID: 0140**



**User Response**

Information only; no action is required.

- **4000008d-00000000 : Remote access attempt failed. Invalid userid or password received. Userid is [arg1] from a CIM client at IP address [arg2].**

This message is for the use case where a remote user has failed to establish a remote control session from CIM.

May also be shown as 4000008d00000000 or 0x4000008d00000000

**Severity**

Info

**Serviceable**

No

**Automatically notify support**

No

**Alert Category**

System - Remote Login

**SNMP Trap ID**

30

**CIM Information**

Prefix: IMM ID: 0141

**User Response**

Information only; no action is required.

- **4000008e-00000000 : Device [arg1] VPD is not valid.**

The VPD for a device is invalid

May also be shown as 4000008e00000000 or 0x4000008e00000000

**Severity**

Warning

**Serviceable**

No

**Automatically notify support**

No

**Alert Category**

System - Other

**SNMP Trap ID**

22

**CIM Information**

Prefix: IMM ID: 0142

**User Response**

Lenovo Support will address the problem.

- **4000008f-00000000 : The bare metal connection process has been started.**

Bare Metal Connection process has been started

May also be shown as 4000008f00000000 or 0x4000008f00000000

**Severity**

Info

**Serviceable**

No

**Automatically notify support**

No

**Alert Category**

System - Other

**SNMP Trap ID**

22

**CIM Information**

Prefix: IMM ID: 0143

**User Response**

Information only; no action is required.

- **40000090-00000000 : The bare metal update application reports a status of [arg1].**

Bare Metal Update Application Status

May also be shown as 4000009000000000 or 0x4000009000000000

**Severity**

Info

**Serviceable**

No

**Automatically notify support**

No

**Alert Category**

System - Other

**SNMP Trap ID**

22

**CIM Information**

Prefix: IMM ID: 0144

**User Response**

Information only; no action is required.

- **40000091-00000000 : User [arg1] has terminated an active console session.**

A user has terminated an active console session

May also be shown as 4000009100000000 or 0x4000009100000000

**Severity**

Info

**Serviceable**

No

**Automatically notify support**

No

**Alert Category**

none

**SNMP Trap ID****CIM Information**

Prefix: IMM ID: 0145

**User Response**

Information only; no action is required.

- **40000092-00000000 : TKLM servers set by user [arg1]: TKLMServer1=[arg2] Port=[arg3], TKLMServer2=[arg4] Port=[arg5], TKLMServer3=[arg6] Port=[arg7], TKLMServer4=[arg8] Port=[arg9].**

A user configured the TKLM servers

May also be shown as 4000009200000000 or 0x4000009200000000

**Severity**

Info

**Serviceable**

No

**Automatically notify support**

No

**Alert Category**

none

**SNMP Trap ID****CIM Information**

Prefix: IMM ID: 0146

**User Response**

Information only; no action is required.

- **40000093-00000000 : TKLM servers device group set by user [arg1]: TKLMServerDeviceGroup=[arg2].**

A user configured the TKLM device group

May also be shown as 4000009300000000 or 0x4000009300000000

**Severity**

Info

**Serviceable**

No

**Automatically notify support**

No

**Alert Category**

none

**SNMP Trap ID****CIM Information**

Prefix: IMM ID: 0147

**User Response**

Information only; no action is required.

- **40000094-00000000 : User [arg1] has generated a new encryption key pair and installed a self-signed certificate for the TKLM client.**

User generated a new encryption key pair and installed a self-signed certificate for the TKLM client

May also be shown as 4000009400000000 or 0x4000009400000000

**Severity**

Info

**Serviceable**

No

**Automatically notify support**

No

**Alert Category**

none

**SNMP Trap ID**

**CIM Information**

Prefix: IMM ID: 0148

**User Response**

Information only; no action is required.

- **40000095-00000000 : User [arg1] has generated a new encryption key and certificate signing request for the TKLM client.**

User generated a new encryption key and certificate signing request for the TKLM client

May also be shown as 4000009500000000 or 0x4000009500000000

**Severity**

Info

**Serviceable**

No

**Automatically notify support**

No

**Alert Category**

none

**SNMP Trap ID**

**CIM Information**

Prefix: IMM ID: 0149

**User Response**

Information only; no action is required.

- **40000096-00000000 : User [arg1] has imported a signed certificate for the TKLM client from [arg2].**

User imported a signed certificate for the TKLM client

May also be shown as 4000009600000000 or 0x4000009600000000

**Severity**

Info

**Serviceable**

No

**Automatically notify support**

No

**Alert Category**

none

**SNMP Trap ID**

**CIM Information**

Prefix: IMM ID: 0150

**User Response**

Information only; no action is required.

- **40000097-00000000 : User [arg1] has imported a server certificate for the TKLM server.**

User imported a server certificate for the TKLM Server

May also be shown as 4000009700000000 or 0x4000009700000000

**Severity**

Info

**Serviceable**

No

**Automatically notify support**

No

**Alert Category**

none

**SNMP Trap ID****CIM Information**

Prefix: IMM ID: 0151

**User Response**

Information only; no action is required.

- **40000098-00000000 : The UEFI Definitions have been changed.**

UEFI Definitions change has been detected

May also be shown as 4000009800000000 or 0x4000009800000000

**Severity**

Info

**Serviceable**

No

**Automatically notify support**

No

**Alert Category**

none

**SNMP Trap ID****CIM Information**

Prefix: IMM ID: 0152

**User Response**

Information only; no action is required.

- **40000099-00000000 : Security: Userid: [arg1] had [arg2] login failures from IPMI client at IP address [arg3].**

This message is for the use case where a user has failed to log in to a Management Controller from IPMI.

May also be shown as 4000009900000000 or 0x4000009900000000

**Severity**

Info

**Serviceable**

No

**Automatically notify support**

No

**Alert Category**

System - Remote Login

**SNMP Trap ID**

30

**CIM Information**

**Prefix: IMM ID:** 0153

**User Response**

Information only; no action is required.

- **4000009a-00000000 : Security: Userid: [arg1] had [arg2] login failures from SNMP client at IP address [arg3].**

This message is for the use case where a user has failed to access a Management Controller from SNMP.

May also be shown as 4000009a00000000 or 0x4000009a00000000

**Severity**

Info

**Serviceable**

No

**Automatically notify support**

No

**Alert Category**

System - Remote Login

**SNMP Trap ID**

30

**CIM Information**

**Prefix: IMM ID:** 0154

**User Response**

Information only; no action is required.

- **4000009b-00000000 : Security: Userid: [arg1] had [arg2] login failures from IPMI serial client.**

This message is for the use case where a user has failed to log in to a Management Controller from IPMI serial client

May also be shown as 4000009b00000000 or 0x4000009b00000000

**Severity**

Info

**Serviceable**

No

**Automatically notify support**

No

**Alert Category**

System - Remote Login

**SNMP Trap ID**

30

**CIM Information**

Prefix: IMM ID: 0155

**User Response**

Information only; no action is required.

- **4000009c-00000000 : Remote Login Successful. Login ID: [arg1] from [arg2] serial interface.**

This message is for the use case where a user successfully logs in to a Management Controller.

May also be shown as 4000009c00000000 or 0x4000009c00000000

**Severity**

Info

**Serviceable**

No

**Automatically notify support**

No

**Alert Category**

System - Remote Login

**SNMP Trap ID**

30

**CIM Information**

Prefix: IMM ID: 0156

**User Response**

Information only; no action is required.

- **4000009d-00000000 : Login ID: [arg1] from [arg2] at IP address [arg3] has logged off.**

This message is for the use case where a user has logged off of a Management Controller.

May also be shown as 4000009d00000000 or 0x4000009d00000000

**Severity**

Info

**Serviceable**

No

**Automatically notify support**

No

**Alert Category**

System - Remote Login

**SNMP Trap ID**

30

**CIM Information**

Prefix: IMM ID: 0157

**User Response**

Information only; no action is required.

- **4000009e-00000000 : Login ID: [arg1] from [arg2] at IP address [arg3] has been logged off.**

This message is for the use case where a user has been logged off of a Management Controller.

May also be shown as 4000009e00000000 or 0x4000009e00000000

**Severity**

Info

**Serviceable**

No

**Automatically notify support**

No

**Alert Category**

System - Remote Login

**SNMP Trap ID**

30

**CIM Information**

Prefix: IMM ID: 0158

**User Response**

Information only; no action is required.

- **4000009f-00000000 : User [arg1] has initiated a TKLM Server Connection Test to check connectivity to server [arg2].**

User initiated a TKLM Server Connection test.

May also be shown as 4000009f00000000 or 0x4000009f00000000

**Severity**

Info

**Serviceable**

No

**Automatically notify support**

No

**Alert Category**

none

**SNMP Trap ID****CIM Information**

Prefix: IMM ID: 0159

**User Response**

Information only; no action is required.

- **400000a0-00000000 : User [arg1] has initiated an SMTP Server Connection Test.**

User initiated an SMTP Server Connection test.

May also be shown as 400000a000000000 or 0x400000a000000000

**Severity**

Info

**Serviceable**

No

**Automatically notify support**

No

**Alert Category**

none



## SNMP Trap ID

### CIM Information

Prefix: IMM ID: 0160

### User Response

Information only; no action is required.

- **400000a1-00000000 : UEFI Reported: [arg1].**

UEFI audit event logged.

May also be shown as 400000a100000000 or 0x400000a100000000

### Severity

Info

### Serviceable

No

### Automatically notify support

No

### Alert Category

none

## SNMP Trap ID

### CIM Information

Prefix: IMM ID: 0161

### User Response

Information only; no action is required.

- **400000a2-00000000 : User [arg1] has [arg2] file [arg3] from [arg4].**

User has mounted/unmounted file from URL or server

May also be shown as 400000a200000000 or 0x400000a200000000

### Severity

Info

### Serviceable

No

### Automatically notify support

No

### Alert Category

System - Other

## SNMP Trap ID

22

### CIM Information

Prefix: IMM ID: 0162

### User Response

Information only; no action is required.

- **400000a3-00000000 : User [arg1] has set the SMTP Server reverse-path to [arg2].**

User set SMTP Server reverse-path address

May also be shown as 400000a300000000 or 0x400000a300000000

**Severity**

Info

**Serviceable**

No

**Automatically notify support**

No

**Alert Category**

System - Other

**SNMP Trap ID**

22

**CIM Information**

Prefix: IMM ID: 0163

**User Response**

Information only; no action is required.

- **400000a4-00000000 : User [arg1] has removed a certificate.**

User removed certificate

May also be shown as 400000a400000000 or 0x400000a400000000

**Severity**

Info

**Serviceable**

No

**Automatically notify support**

No

**Alert Category**

System - Other

**SNMP Trap ID**

22

**CIM Information**

Prefix: IMM ID: 0164

**User Response**

Information only; no action is required.

- **400000a5-00000000 : A certificate has been revoked.**

A certificate has been revoked

May also be shown as 400000a500000000 or 0x400000a500000000

**Severity**

Info

**Serviceable**

No

**Automatically notify support**

No

**Alert Category**

System - Other

**SNMP Trap ID**

22

**CIM Information**

Prefix: IMM ID: 0165

**User Response**

Information only; no action is required.

- **400000a6-00000000 : The server was restarted for an unknown reason.**

The server was restarted for an unknown reason

May also be shown as 400000a600000000 or 0x400000a600000000

**Severity**

Info

**Serviceable**

No

**Automatically notify support**

No

**Alert Category**

System - Other

**SNMP Trap ID**

22

**CIM Information**

Prefix: IMM ID: 0166

**User Response**

Information only; no action is required.

- **400000a7-00000000 : The server is restarted by chassis control command.**

Server is restarted by chassis control command

May also be shown as 400000a700000000 or 0x400000a700000000

**Severity**

Info

**Serviceable**

No

**Automatically notify support**

No

**Alert Category**

System - Other

**SNMP Trap ID**

22

**CIM Information**

Prefix: IMM ID: 0167

**User Response**

Information only; no action is required.

- **400000a8-00000000 : The server was reset via pushbutton.**

Server was reset via pushbutton

May also be shown as 400000a800000000 or 0x400000a800000000

**Severity**

Info

**Serviceable**

No

**Automatically notify support**

No

**Alert Category**

System - Other

**SNMP Trap ID**

22

**CIM Information**

Prefix: IMM ID: 0168

**User Response**

Information only; no action is required.

- **400000a9-00000000 : The server was powered-up via power pushbutton.**

Server was power-up via power pushbutton

May also be shown as 400000a900000000 or 0x400000a900000000

**Severity**

Info

**Serviceable**

No

**Automatically notify support**

No

**Alert Category**

System - Other

**SNMP Trap ID**

22

**CIM Information**

Prefix: IMM ID: 0169

**User Response**

Information only; no action is required.

- **400000aa-00000000 : The server was restarted when the watchdog expired..**

Server was restarted when the watchdog expired.

May also be shown as 400000aa00000000 or 0x400000aa00000000

**Severity**

Info

**Serviceable**

No

**Automatically notify support**

No

**Alert Category**

System - Other

**SNMP Trap ID**

22

**CIM Information**

Prefix: IMM ID: 0170

**User Response**

Information only; no action is required.

- **400000ab-00000000 : The server was restarted for OEM reason.**

Server was restarted for OEM reason

May also be shown as 400000ab00000000 or 0x400000ab00000000

**Severity**

Info

**Serviceable**

No

**Automatically notify support**

No

**Alert Category**

System - Other

**SNMP Trap ID**

22

**CIM Information**

Prefix: IMM ID: 0171

**User Response**

Information only; no action is required.

- **400000ac-00000000 : The server was automatically powered on because the power restore policy is set to always restore..**

Server was automatically powered on because the power restore policy is set to always restore.

May also be shown as 400000ac00000000 or 0x400000ac00000000

**Severity**

Info

**Serviceable**

No

**Automatically notify support**

No

**Alert Category**

System - Other

**SNMP Trap ID**

22

**CIM Information**

Prefix: IMM ID: 0172

**User Response**

Information only; no action is required.

- **400000ad-00000000 : The server was automatically powered on because the power restore policy is set to restore previous power state..**

Server was automatically powered on because the power restore policy is set to restore previous power state.

May also be shown as 400000ad00000000 or 0x400000ad00000000

**Severity**

Info

**Serviceable**

No

**Automatically notify support**

No

**Alert Category**

System - Other

**SNMP Trap ID**

22

**CIM Information**

Prefix: IMM ID: 0173

**User Response**

Information only; no action is required.

- **400000ae-00000000 : The server was reset via Platform Event Filter.**

Server was reset via Platform Event Filter

May also be shown as 400000ae00000000 or 0x400000ae00000000

**Severity**

Info

**Serviceable**

No

**Automatically notify support**

No

**Alert Category**

System - Other

**SNMP Trap ID**

22

**CIM Information**

Prefix: IMM ID: 0174

**User Response**

Information only; no action is required.

- **400000af-00000000 : The server was power-cycled via Platform Event Filter.**

Server was power-cycled via Platform Event Filter

May also be shown as 400000af00000000 or 0x400000af00000000

**Severity**

Info

**Serviceable**

No

**Automatically notify support**

No

**Alert Category**

System - Other

**SNMP Trap ID**

22

**CIM Information**

Prefix: IMM ID: 0175

**User Response**

Information only; no action is required.

- **400000b0-00000000 : The server was soft reset.**

Server was soft reset

May also be shown as 400000b000000000 or 0x400000b000000000

**Severity**

Info

**Serviceable**

No

**Automatically notify support**

No

**Alert Category**

System - Other

**SNMP Trap ID**

22

**CIM Information**

Prefix: IMM ID: 0176

**User Response**

Information only; no action is required.

- **400000b1-00000000 : The server was powered up via Real Time Clock (scheduled power on).**

Server was powered up via Real Time Clock (scheduled power on)

May also be shown as 400000b100000000 or 0x400000b100000000

**Severity**

Info

**Serviceable**

No

**Automatically notify support**

No

**Alert Category**

System - Other

**SNMP Trap ID**

22

**CIM Information**

Prefix: IMM ID: 0177

**User Response**

Information only; no action is required.

- **400000b2-00000000 : The server was powered off for an unknown reason.**

Server was powered off for an unknown reason

May also be shown as 400000b200000000 or 0x400000b200000000

**Severity**

Info

**Serviceable**

No

**Automatically notify support**

No

**Alert Category**

System - Other

**SNMP Trap ID**

22

**CIM Information**

Prefix: IMM ID: 0178

**User Response**

Information only; no action is required.

- **400000b3-00000000 : The server was powered off by chassis control command.**

Server was powered off by chassis control command

May also be shown as 400000b300000000 or 0x400000b300000000

**Severity**

Info

**Serviceable**

No

**Automatically notify support**

No

**Alert Category**

System - Other

**SNMP Trap ID**

22

**CIM Information**

Prefix: IMM ID: 0179

**User Response**

Information only; no action is required.

- **400000b4-00000000 : The server was powered off via pushbutton.**

Server was powered off via pushbutton

May also be shown as 400000b400000000 or 0x400000b400000000

**Severity**

Info

**Serviceable**

No

**Automatically notify support**

No

**Alert Category**

System - Other

**SNMP Trap ID**

22

**CIM Information**

Prefix: IMM ID: 0180

**User Response**



Information only; no action is required.

- **400000b5-00000000 : The server was powered off when the watchdog expired.**

Server was powered off when the watchdog expired.

May also be shown as 400000b500000000 or 0x400000b500000000

**Severity**

Info

**Serviceable**

No

**Automatically notify support**

No

**Alert Category**

System - Other

**SNMP Trap ID**

22

**CIM Information**

Prefix: IMM ID: 0181

**User Response**

Information only; no action is required.

- **400000b6-00000000 : The server stayed powered off because the power restore policy is set to always restore..**

Server stayed powered off because the power restore policy is set to always restore.

May also be shown as 400000b600000000 or 0x400000b600000000

**Severity**

Info

**Serviceable**

No

**Automatically notify support**

No

**Alert Category**

System - Other

**SNMP Trap ID**

22

**CIM Information**

Prefix: IMM ID: 0182

**User Response**

Information only; no action is required.

- **400000b7-00000000 : The server stayed powered off because the power restore policy is set to restore previous power state..**

Server stayed powered off because the power restore policy is set to restore previous power state.

May also be shown as 400000b700000000 or 0x400000b700000000

**Severity**

Info

**Serviceable**

No

**Automatically notify support**

No

**Alert Category**

System - Other

**SNMP Trap ID**

22

**CIM Information**

Prefix: IMM ID: 0183

**User Response**

Information only; no action is required.

- **400000b8-00000000 : The server was powered off via Platform Event Filter.**

Server was power off via Platform Event Filter

May also be shown as 400000b800000000 or 0x400000b800000000

**Severity**

Info

**Serviceable**

No

**Automatically notify support**

No

**Alert Category**

System - Other

**SNMP Trap ID**

22

**CIM Information**

Prefix: IMM ID: 0184

**User Response**

Information only; no action is required.

- **400000b9-00000000 : The server was powered off via Real Time Clock (scheduled power off).**

Server was powered up via Real Time Clock (scheduled power off)

May also be shown as 400000b900000000 or 0x400000b900000000

**Severity**

Info

**Serviceable**

No

**Automatically notify support**

No

**Alert Category**

System - Other

**SNMP Trap ID**

22

**CIM Information**

Prefix: IMM ID: 0185

**User Response**

Information only; no action is required.

- **400000ba-00000000 : Management Controller [arg1] reset was initiated due to Power-On-Reset.**

Management Controller reset was initiated due to Power-On-Reset

May also be shown as 400000ba00000000 or 0x400000ba00000000

**Severity**

Info

**Serviceable**

No

**Automatically notify support**

No

**Alert Category**

System - Other

**SNMP Trap ID**

22

**CIM Information**

Prefix: IMM ID: 0186

**User Response**

Information only; no action is required.

- **400000bb-00000000 : Management Controller [arg1] reset was initiated by PRESET.**

Management Controller reset was initiated by PRESET

May also be shown as 400000bb00000000 or 0x400000bb00000000

**Severity**

Info

**Serviceable**

No

**Automatically notify support**

No

**Alert Category**

System - Other

**SNMP Trap ID**

22

**CIM Information**

Prefix: IMM ID: 0187

**User Response**

Information only; no action is required.

- **400000bc-00000000 : Management Controller [arg1] reset was initiated by CMM.**

Management Controller reset was initiated by CMM

May also be shown as 400000bc00000000 or 0x400000bc00000000

**Severity**

Info

**Serviceable**

No

**Automatically notify support**

No

**Alert Category**

System - Other

**SNMP Trap ID**

22

**CIM Information**

Prefix: IMM ID: 0188

**User Response**

Information only; no action is required.

- **400000bd-00000000 : Management Controller [arg1] reset was initiated by IMM firmware.**

Management Controller reset was initiated by IMM firmware

May also be shown as 400000bd00000000 or 0x400000bd00000000

**Severity**

Info

**Serviceable**

No

**Automatically notify support**

No

**Alert Category**

System - Other

**SNMP Trap ID**

22

**CIM Information**

Prefix: IMM ID: 0189

**User Response**

Information only; no action is required.

- **400000be-00000000 : The [arg1] certificate is expired and has been removed.**

Expired certificate has been removed

May also be shown as 400000be00000000 or 0x400000be00000000

**Severity**

Info

**Serviceable**

No

**Automatically notify support**

No

**Alert Category**

System - Other

**SNMP Trap ID**

22

**CIM Information**

Prefix: IMM ID: 0190

**User Response**

Information only; no action is required.

- **400000bf-00000000 : Operating System status has changed to [arg1].**

Operating System status change

May also be shown as 400000bf00000000 or 0x400000bf00000000

**Severity**

Info

**Serviceable**

No

**Automatically notify support**

No

**Alert Category**

System - Other

**SNMP Trap ID**

22

**CIM Information**

Prefix: IMM ID: 0191

**User Response**

Information only; no action is required.

- **400000c1-00000000 : System running in setup.**

System running in setup

May also be shown as 400000c100000000 or 0x400000c100000000

**Severity**

Info

**Serviceable**

No

**Automatically notify support**

No

**Alert Category**

System - Other

**SNMP Trap ID**

22

**CIM Information**

Prefix: IMM ID: 0193

**User Response**

Information only; no action is required.

- **400000c2-00000000 : Remote Control session started by user [arg1] in [arg2] mode has been closed.**

Remote Control session closed

May also be shown as 400000c200000000 or 0x400000c200000000

**Severity**

Info

**Serviceable**

No

**Automatically notify support**

No

**Alert Category**

System - Other

**SNMP Trap ID**

22

**CIM Information**

Prefix: IMM ID: 0194

**User Response**

Information only; no action is required.

- **400000c3-00000000 : Call Home to [arg1] failed to complete: [arg2].**

Call Home failed to complete.

May also be shown as 400000c300000000 or 0x400000c300000000

**Severity**

Info

**Serviceable**

No

**Automatically notify support**

No

**Alert Category**

System - Other

**SNMP Trap ID**

22

**CIM Information**

Prefix: IMM ID: 0195

**User Response**

Information only; no action is required.

- **400000c4-00000000 : IMM failed to log previous event [arg1].**

IMM failed to log a previous event.

May also be shown as 400000c400000000 or 0x400000c400000000

**Severity**

Info

**Serviceable**

No

**Automatically notify support**

No

**Alert Category**

System - Other

**SNMP Trap ID**

22

**CIM Information**

Prefix: IMM ID: 0196

**User Response**

Information only; no action is required.

- **400000c5-00000000 : UEFI deployment boot mode is enabled for NextBoot.**

UEFI deployment boot mode is enabled for NextBoot

May also be shown as 400000c500000000 or 0x400000c500000000

**Severity**

Info

**Serviceable**

No

**Automatically notify support**

No

**Alert Category**

System - Other

**SNMP Trap ID**

22

**CIM Information**

Prefix: IMM ID: 0197

**User Response**

Information only; no action is required.

- **400000c6-00000000 : UEFI deployment boot mode is enabled for NextAc.**

UEFI deployment boot mode is enabled for NextAC

May also be shown as 400000c600000000 or 0x400000c600000000

**Severity**

Info

**Serviceable**

No

**Automatically notify support**

No

**Alert Category**

System - Other

**SNMP Trap ID**

22

**CIM Information**

Prefix: IMM ID: 0198

**User Response**

Information only; no action is required.

- **400000c7-00000000 : UEFI deployment boot mode has been disabled.**

UEFI deployment boot mode has been disabled

May also be shown as 400000c700000000 or 0x400000c700000000

**Severity**

Info

**Serviceable**

No

**Automatically notify support**

No

**Alert Category**

System - Other

**SNMP Trap ID**

22

**CIM Information**

Prefix: IMM ID: 0199

**User Response**

Information only; no action is required.

- **400000c9-00000000 : User [arg1] made system [arg2] Encapsulation lite Mode.**

Encapsulation lite mode status change

May also be shown as 400000c900000000 or 0x400000c900000000

**Severity**

Info

**Serviceable**

No

**Automatically notify support**

No

**Alert Category**

System - Other

**SNMP Trap ID**

22

**CIM Information**

Prefix: IMM ID: 0201

**User Response**

Information only; no action is required.

- **400000ca-00000000 : Battery error was detected by RAID controller. The battery unit needs replacement.([arg1],[arg2],[arg3],[arg4],[arg5])**

Battery error was detected by RAID controller

May also be shown as 400000ca00000000 or 0x400000ca00000000

**Severity**

Info

**Serviceable**

No

**Automatically notify support**

No

**Alert Category**

System - Other

**SNMP Trap ID**

22

**CIM Information**

Prefix: IMM ID: 0202

**User Response**



Check storage documentation by LSI Event ID.

- **400000cb-00000000 : The RAID controller has problem with the battery. Please contact technical support to resolve this issue.([arg1],[arg2],[arg3],[arg4],[arg5])**

The RAID controller has problem with the battery

May also be shown as 400000cb00000000 or 0x400000cb00000000

**Severity**

Info

**Serviceable**

No

**Automatically notify support**

Yes

**Alert Category**

System - Other

**SNMP Trap ID**

22

**CIM Information**

Prefix: IMM ID: 0203

**User Response**

Check storage documentation by LSI Event ID.

- **400000cc-00000000 : The RAID controller detected unrecoverable error. The controller needs replacement.([arg1],[arg2],[arg3],[arg4],[arg5])**

The RAID controller detected unrecoverable error

May also be shown as 400000cc00000000 or 0x400000cc00000000

**Severity**

Info

**Serviceable**

No

**Automatically notify support**

Yes

**Alert Category**

System - Other

**SNMP Trap ID**

22

**CIM Information**

Prefix: IMM ID: 0204

**User Response**

Check storage documentation by LSI Event ID.

- **400000cd-00000000 : The RAID controller detected one or more problems. Please contact technical support for additional assistance.([arg1],[arg2],[arg3],[arg4],[arg5])**

The RAID controller detected one or more problems

May also be shown as 400000cd00000000 or 0x400000cd00000000

**Severity**

Info

**Serviceable**

No

**Automatically notify support**

No

**Alert Category**

System - Other

**SNMP Trap ID**

22

**CIM Information**

Prefix: IMM ID: 0205

**User Response**

Check storage documentation by LSI Event ID.

- **400000ce-00000000 : The RAID controller detected one or more possible configuration changes within the subsystem. Please check the drive LED status. If necessary, contact technical support for additional assistance.([arg1],[arg2],[arg3],[arg4],[arg5])**

The RAID controller detected one or more possible configuration changes within the subsystem

May also be shown as 400000ce00000000 or 0x400000ce00000000

**Severity**

Info

**Serviceable**

No

**Automatically notify support**

No

**Alert Category**

System - Other

**SNMP Trap ID**

22

**CIM Information**

Prefix: IMM ID: 0206

**User Response**

Check storage documentation by LSI Event ID.

- **400000cf-00000000 : Enclosure issue detected with one or more units. Please check the enclosure units to repair the problem.([arg1],[arg2],[arg3],[arg4],[arg5])**

Enclosure issue detected with one or more units

May also be shown as 400000cf00000000 or 0x400000cf00000000

**Severity**

Info

**Serviceable**

No

**Automatically notify support**

No

**Alert Category**

System - Other

**SNMP Trap ID**

**CIM Information****Prefix: IMM ID:** 0207**User Response**

Lenovo Support will address the problem.

- **400000d0-00000000 : Connectivity issue detected with the enclosure. Please check your cable configurations to repair the problem.([arg1],[arg2],[arg3],[arg4],[arg5])**

Connectivity issue detected with the enclosure

May also be shown as 400000d000000000 or 0x400000d000000000

**Severity**

Info

**Serviceable**

No

**Automatically notify support**

No

**Alert Category**

System - Other

**SNMP Trap ID**

22

**CIM Information****Prefix: IMM ID:** 0208**User Response**

Lenovo Support will address the problem.

- **400000d1-00000000 : Fan problem detected with the enclosure. Please check the enclosure unit fan for correct operation.([arg1],[arg2],[arg3],[arg4],[arg5])**

Fan problem detected with the enclosure

May also be shown as 400000d100000000 or 0x400000d100000000

**Severity**

Info

**Serviceable**

No

**Automatically notify support**

No

**Alert Category**

System - Other

**SNMP Trap ID**

22

**CIM Information****Prefix: IMM ID:** 0209**User Response**

Lenovo Support will address the problem.

- **400000d2-00000000 : Enclosure power supply has problem. Please check the enclosure unit power supply for correct operation.([arg1],[arg2],[arg3],[arg4],[arg5])**

Enclosure power supply has problem

May also be shown as 400000d200000000 or 0x400000d200000000

**Severity**

Info

**Serviceable**

No

**Automatically notify support**

No

**Alert Category**

System - Other

**SNMP Trap ID**

22

**CIM Information**

Prefix: IMM ID: 0210

**User Response**

Lenovo Support will address the problem.

- **400000d3-00000000 : One or more virtual drive are in abnormal status that may cause unavailable virtual drive. Please check the event logs and if events are targeted to the same disk then replace the drive. If necessary, contact technical support for additional assistance.([arg1],[arg2],[arg3],[arg4],[arg5])**

One or more virtual drive are in abnormal status that may cause unavailable virtual drive

May also be shown as 400000d300000000 or 0x400000d300000000

**Severity**

Info

**Serviceable**

No

**Automatically notify support**

No

**Alert Category**

System - Other

**SNMP Trap ID**

22

**CIM Information**

Prefix: IMM ID: 0211

**User Response**

Check storage documentation by LSI Event ID.

- **400000d4-00000000 : The RAID controller detected one or more possible configuration problem within the subsystem. Please check the event logs and if events are targeted to the same disk then replace the drive. If necessary, contact technical support for additional assistance.([arg1],[arg2],[arg3],[arg4],[arg5])**

The RAID controller detected one or more possible configuration problem within the subsystem

May also be shown as 400000d400000000 or 0x400000d400000000

**Severity**

Info

**Serviceable**

No

**Automatically notify support**

No

**Alert Category**

System - Other

**SNMP Trap ID**

22

**CIM Information**

**Prefix: IMM ID:** 0212

**User Response**

Check storage documentation by LSI Event ID.

- **400000d5-00000000 : One or more virtual drive have problem. Please contact technical support to resolve this issue.([arg1],[arg2],[arg3],[arg4],[arg5])**

One or more virtual drive have problem

May also be shown as 400000d500000000 or 0x400000d500000000

**Severity**

Info

**Serviceable**

No

**Automatically notify support**

Yes

**Alert Category**

System - Other

**SNMP Trap ID**

22

**CIM Information**

**Prefix: IMM ID:** 0213

**User Response**

Check storage documentation by LSI Event ID.

- **400000d6-00000000 : Drive error was detected by RAID controller. Please contact technical support to resolve this issue.([arg1],[arg2],[arg3],[arg4],[arg5])**

Drive error was detected by RAID controller

May also be shown as 400000d600000000 or 0x400000d600000000

**Severity**

Info

**Serviceable**

No

**Automatically notify support**

Yes

**Alert Category**

System - Other

**SNMP Trap ID**

22

**CIM Information**

**Prefix: IMM ID: 0214**

**User Response**

Check storage documentation by LSI Event ID.

- **400000d7-00000000 : Drive error was detected by RAID controller. Please check the event logs and if events are targeted to the same disk then replace the drive. If necessary, contact technical support for additional assistance.([arg1],[arg2],[arg3],[arg4],[arg5])**

Drive error was detected by RAID controller

May also be shown as 400000d700000000 or 0x400000d700000000

**Severity**

Info

**Serviceable**

No

**Automatically notify support**

No

**Alert Category**

System - Other

**SNMP Trap ID**

22

**CIM Information**

**Prefix: IMM ID: 0215**

**User Response**

Check storage documentation by LSI Event ID.

- **80010002-0701ffff : Numeric sensor [NumericSensorElementName] going low (lower non-critical) has asserted. (CMOS Battery)**

This message is for the use case when an implementation has detected a Lower Non-critical sensor going low has asserted.

May also be shown as 800100020701ffff or 0x800100020701ffff

**Severity**

Warning

**Serviceable**

Yes

**Automatically notify support**

No

**Alert Category**

Warning - Voltage

**SNMP Trap ID**

13

**CIM Information**

**Prefix: PLAT ID: 0476**

**User Response**

Replace the system battery.

- **80010202-0701ffff : Numeric sensor [NumericSensorElementName] going low (lower critical) has asserted. (CMOS Battery)**

This message is for the use case when an implementation has detected a Lower Critical sensor going low has asserted.

May also be shown as 800102020701ffff or 0x800102020701ffff

**Severity**

Error

**Serviceable**

Yes

**Automatically notify support**

Yes

**Alert Category**

Critical - Voltage

**SNMP Trap ID**

1

**CIM Information**

**Prefix: PLAT ID:** 0480

**User Response**

If the specified sensor is CMOS battery, replace the system battery. If the specified sensor is Planar 3.3V or Planar 5V, (trained technician only) replace the system board. If the specified sensor is Planar 12V, complete the following steps until the problem is solved:

1. Check power supply n LED.
2. Remove the failing power supply.
3. Follow actions in "Power Problems and Solving Power Problems".
4. (Trained technician only) Replace the system board. (n = power supply number)

SysBrd 12V : SysBrd 3.3V : SysBrd 5V :

- **80010204-1d01ffff : Numeric sensor [NumericSensorElementName] going low (lower critical) has asserted. (Fan 1A Tach)**

This message is for the use case when an implementation has detected a Lower Critical sensor going low has asserted.

May also be shown as 800102041d01ffff or 0x800102041d01ffff

**Severity**

Error

**Serviceable**

Yes

**Automatically notify support**

No

**Alert Category**

Critical - Fan Failure

**SNMP Trap ID**

11

**CIM Information**

**Prefix: PLAT ID:** 0480

**User Response**

1. Reseat the failing fan n, which is indicated by a lit LED near the fan connector on the system board.
2. Replace the failing fan. (n = fan number)

Fan 1B Tach :

- **80010204-1d02ffff : Numeric sensor [NumericSensorElementName] going low (lower critical) has asserted. (Fan 2A Tach)**

This message is for the use case when an implementation has detected a Lower Critical sensor going low has asserted.

May also be shown as 800102041d02ffff or 0x800102041d02ffff

**Severity**

Error

**Serviceable**

Yes

**Automatically notify support**

No

**Alert Category**

Critical - Fan Failure

**SNMP Trap ID**

11

**CIM Information**

**Prefix: PLAT ID: 0480**

**User Response**

1. Reseat the failing fan n, which is indicated by a lit LED near the fan connector on the system board.
2. Replace the failing fan. (n = fan number)

Fan 2B Tach :

- **80010204-1d03ffff : Numeric sensor [NumericSensorElementName] going low (lower critical) has asserted. (Fan 3A Tach)**

This message is for the use case when an implementation has detected a Lower Critical sensor going low has asserted.

May also be shown as 800102041d03ffff or 0x800102041d03ffff

**Severity**

Error

**Serviceable**

Yes

**Automatically notify support**

No

**Alert Category**

Critical - Fan Failure

**SNMP Trap ID**

11

**CIM Information**

**Prefix: PLAT ID: 0480**

**User Response**

1. Reseat the failing fan n, which is indicated by a lit LED near the fan connector on the system board.
2. Replace the failing fan. (n = fan number)



Fan 3B Tach :

- **80010204-1d04ffff : Numeric sensor [NumericSensorElementName] going low (lower critical) has asserted. (Fan 4A Tach)**

This message is for the use case when an implementation has detected a Lower Critical sensor going low has asserted.

May also be shown as 800102041d04ffff or 0x800102041d04ffff

**Severity**

Error

**Serviceable**

Yes

**Automatically notify support**

No

**Alert Category**

Critical - Fan Failure

**SNMP Trap ID**

11

**CIM Information**

**Prefix:** PLAT ID: 0480

**User Response**

1. Reseat the failing fan n, which is indicated by a lit LED near the fan connector on the system board.
2. Replace the failing fan. (n = fan number)

Fan 4B Tach :

- **80010204-1d05ffff : Numeric sensor [NumericSensorElementName] going low (lower critical) has asserted. (Fan 5A Tach)**

This message is for the use case when an implementation has detected a Lower Critical sensor going low has asserted.

May also be shown as 800102041d05ffff or 0x800102041d05ffff

**Severity**

Error

**Serviceable**

Yes

**Automatically notify support**

No

**Alert Category**

Critical - Fan Failure

**SNMP Trap ID**

11

**CIM Information**

**Prefix:** PLAT ID: 0480

**User Response**

1. Reseat the failing fan n, which is indicated by a lit LED near the fan connector on the system board.
2. Replace the failing fan. (n = fan number)

Fan 5B Tach :

- **80010204-1d06ffff : Numeric sensor [NumericSensorElementName] going low (lower critical) has asserted. (Fan 6A Tach)**

This message is for the use case when an implementation has detected a Lower Critical sensor going low has asserted.

May also be shown as 800102041d06ffff or 0x800102041d06ffff

**Severity**

Error

**Serviceable**

Yes

**Automatically notify support**

No

**Alert Category**

Critical - Fan Failure

**SNMP Trap ID**

11

**CIM Information**

**Prefix: PLAT ID: 0480**

**User Response**

1. Reseat the failing fan n, which is indicated by a lit LED near the fan connector on the system board.
2. Replace the failing fan. (n = fan number)

Fan 6B Tach :

- **80010204-1d07ffff : Numeric sensor [NumericSensorElementName] going low (lower critical) has asserted. (Fan Riser1A Tach)**

This message is for the use case when an implementation has detected a Lower Critical sensor going low has asserted.

May also be shown as 800102041d07ffff or 0x800102041d07ffff

**Severity**

Error

**Serviceable**

Yes

**Automatically notify support**

No

**Alert Category**

Critical - Fan Failure

**SNMP Trap ID**

11

**CIM Information**

**Prefix: PLAT ID: 0480**

**User Response**

1. Reseat rear hdd cage riser n.
2. Remove the following component and identify the problem. a. HDD drive b. HDD cable c. RAID card d. cage riser n

3. Replace rear hdd cage riser n (n = riser number).
- **80010204-1d08ffff : Numeric sensor [NumericSensorElementName] going low (lower critical) has asserted. (Fan Riser1B Tach)**

This message is for the use case when an implementation has detected a Lower Critical sensor going low has asserted.

May also be shown as 800102041d08ffff or 0x800102041d08ffff

**Severity**

Error

**Serviceable**

Yes

**Automatically notify support**

No

**Alert Category**

Critical - Fan Failure

**SNMP Trap ID**

11

**CIM Information**

**Prefix:** PLAT ID: 0480

**User Response**

1. Reseat rear hdd cage riser n.
  2. Remove the following component and identify the problem. a. HDD drive b. HDD cable c. RAID card d. cage riser n
  3. Replace rear hdd cage riser n (n = riser number).
- **80010204-1d09ffff : Numeric sensor [NumericSensorElementName] going low (lower critical) has asserted. (Fan Riser2A Tach)**

This message is for the use case when an implementation has detected a Lower Critical sensor going low has asserted.

May also be shown as 800102041d09ffff or 0x800102041d09ffff

**Severity**

Error

**Serviceable**

Yes

**Automatically notify support**

No

**Alert Category**

Critical - Fan Failure

**SNMP Trap ID**

11

**CIM Information**

**Prefix:** PLAT ID: 0480

**User Response**

1. Reseat rear hdd cage riser n.
2. Remove the following component and identify the problem. a. HDD drive b. HDD cable c. RAID card d. cage riser n

3. Replace rear hdd cage riser n (n = riser number).
- **80010204-1d0affff : Numeric sensor [NumericSensorElementName] going low (lower critical) has asserted. (Fan Riser2B Tach)**

This message is for the use case when an implementation has detected a Lower Critical sensor going low has asserted.

May also be shown as 800102041d0affff or 0x800102041d0affff

**Severity**

Error

**Serviceable**

Yes

**Automatically notify support**

No

**Alert Category**

Critical - Fan Failure

**SNMP Trap ID**

11

**CIM Information**

**Prefix: PLAT ID:** 0480

**User Response**

1. Reseat rear hdd cage riser n.
  2. Remove the following component and identify the problem. a. HDD drive b. HDD cable c. RAID card d. cage riser n
  3. Replace rear hdd cage riser n (n = riser number).
- **80010701-0701ffff : Numeric sensor [NumericSensorElementName] going high (upper non-critical) has asserted. (RS1 RR Amb Temp)**

This message is for the use case when an implementation has detected an Upper Non-critical sensor going high has asserted.

May also be shown as 800107010701ffff or 0x800107010701ffff

**Severity**

Warning

**Serviceable**

Yes

**Automatically notify support**

No

**Alert Category**

Warning - Temperature

**SNMP Trap ID**

12

**CIM Information**

**Prefix: PLAT ID:** 0490

**User Response**

1. Make sure that the fans are operating, that there are no obstructions to the airflow (front and rear of the server), that the air baffle is in place and correctly installed, and that the server cover is installed and completely closed.

2. Check the ambient temperature. You must be operating within the specifications (see Server Features and specifications for more information).
  3. (Trained technician only) Replace system board.
- **80010701-0702ffff : Numeric sensor [NumericSensorElementName] going high (upper non-critical) has asserted. (RS2 RR Amb Temp)**

This message is for the use case when an implementation has detected an Upper Non-critical sensor going high has asserted.

May also be shown as 800107010702ffff or 0x800107010702ffff

**Severity**

Warning

**Serviceable**

Yes

**Automatically notify support**

No

**Alert Category**

Warning - Temperature

**SNMP Trap ID**

12

**CIM Information**

**Prefix:** PLAT ID: 0490

**User Response**

1. Make sure that the fans are operating, that there are no obstructions to the airflow (front and rear of the server), that the air baffle is in place and correctly installed, and that the server cover is installed and completely closed.
  2. Check the ambient temperature. You must be operating within the specifications (see Server Features and specifications for more information).
  3. (Trained technician only) Replace system board.
- **80010701-0703ffff : Numeric sensor [NumericSensorElementName] going high (upper non-critical) has asserted. (MID1 RR Amb Temp)**

This message is for the use case when an implementation has detected an Upper Non-critical sensor going high has asserted.

May also be shown as 800107010703ffff or 0x800107010703ffff

**Severity**

Warning

**Serviceable**

Yes

**Automatically notify support**

No

**Alert Category**

Warning - Temperature

**SNMP Trap ID**

12

**CIM Information**

**Prefix:** PLAT ID: 0490

### User Response

1. Make sure that the fans are operating, that there are no obstructions to the airflow (front and rear of the server), that the air baffle is in place and correctly installed, and that the server cover is installed and completely closed.
  2. Check the ambient temperature. You must be operating within the specifications (see Server Features and specifications for more information).
  3. (Trained technician only) Replace system board.
- **80010701-0704ffff : Numeric sensor [NumericSensorElementName] going high (upper non-critical) has asserted. (MID2 RR Amb Temp)**

This message is for the use case when an implementation has detected an Upper Non-critical sensor going high has asserted.

May also be shown as 800107010704ffff or 0x800107010704ffff

### Severity

Warning

### Serviceable

Yes

### Automatically notify support

No

### Alert Category

Warning - Temperature

### SNMP Trap ID

12

### CIM Information

Prefix: PLAT ID: 0490

### User Response

1. Make sure that the fans are operating, that there are no obstructions to the airflow (front and rear of the server), that the air baffle is in place and correctly installed, and that the server cover is installed and completely closed.
  2. Check the ambient temperature. You must be operating within the specifications (see Server Features and specifications for more information).
  3. (Trained technician only) Replace system board.
- **80010701-0705ffff : Numeric sensor [NumericSensorElementName] going high (upper non-critical) has asserted. (RAID RR Amb Temp)**

This message is for the use case when an implementation has detected an Upper Non-critical sensor going high has asserted.

May also be shown as 800107010705ffff or 0x800107010705ffff

### Severity

Warning

### Serviceable

Yes

### Automatically notify support

No

### Alert Category

Warning - Temperature

**SNMP Trap ID**

12

**CIM Information****Prefix:** PLAT ID: 0490**User Response**

1. Make sure that the fans are operating, that there are no obstructions to the airflow (front and rear of the server), that the air baffle is in place and correctly installed, and that the server cover is installed and completely closed.
  2. Check the ambient temperature. You must be operating within the specifications (see Server Features and specifications for more information).
  3. (Trained technician only) Replace system board.
- **80010701-0706ffff : Numeric sensor [NumericSensorElementName] going high (upper non-critical) has asserted. (PSU FR Amb Temp)**

This message is for the use case when an implementation has detected an Upper Non-critical sensor going high has asserted.

May also be shown as 800107010706ffff or 0x800107010706ffff

**Severity**

Warning

**Serviceable**

Yes

**Automatically notify support**

No

**Alert Category**

Warning - Temperature

**SNMP Trap ID**

12

**CIM Information****Prefix:** PLAT ID: 0490**User Response**

1. Make sure that the fans are operating, that there are no obstructions to the airflow (front and rear of the server), that the air baffle is in place and correctly installed, and that the server cover is installed and completely closed.
  2. Check the ambient temperature. You must be operating within the specifications (see Server Features and specifications for more information).
  3. Replace power supply.
- **80010701-0707ffff : Numeric sensor [NumericSensorElementName] going high (upper non-critical) has asserted. (Rear BP1 Temp)**

This message is for the use case when an implementation has detected an Upper Non-critical sensor going high has asserted.

May also be shown as 800107010707ffff or 0x800107010707ffff

**Severity**

Warning

**Serviceable**

Yes

**Automatically notify support**

No

**Alert Category**

Warning - Temperature

**SNMP Trap ID**

12

**CIM Information**

Prefix: PLAT ID: 0490

**User Response**

1. Make sure that the fans are operating, that there are no obstructions to the airflow (front and rear of the server), that the air baffle is in place and correctly installed, and that the server cover is installed and completely closed.
  2. Check the ambient temperature. You must be operating within the specifications (see Server Features and specifications for more information).
  3. Check fan cable on rear HDD cable is connected correctly.
  4. Check the fans on rear HDD cage are functional.
  5. Replace rear HDD drive cage.
- **80010701-0708ffff : Numeric sensor [NumericSensorElementName] going high (upper non-critical) has asserted. (Rear BP2 Temp)**

This message is for the use case when an implementation has detected an Upper Non-critical sensor going high has asserted.

May also be shown as 800107010708ffff or 0x800107010708ffff

**Severity**

Warning

**Serviceable**

Yes

**Automatically notify support**

No

**Alert Category**

Warning - Temperature

**SNMP Trap ID**

12

**CIM Information**

Prefix: PLAT ID: 0490

**User Response**

1. Make sure that the fans are operating, that there are no obstructions to the airflow (front and rear of the server), that the air baffle is in place and correctly installed, and that the server cover is installed and completely closed.
  2. Check the ambient temperature. You must be operating within the specifications (see Server Features and specifications for more information).
  3. Check fan cable on rear HDD cable is connected correctly.
  4. Check the fans on rear HDD cage are functional.
  5. Replace rear HDD drive cage.
- **80010701-1401ffff : Numeric sensor [NumericSensorElementName] going high (upper non-critical) has asserted. (CPU1 VR Temp)**



This message is for the use case when an implementation has detected an Upper Non-critical sensor going high has asserted.

May also be shown as 800107011401ffff or 0x800107011401ffff

**Severity**

Warning

**Serviceable**

Yes

**Automatically notify support**

No

**Alert Category**

Warning - Temperature

**SNMP Trap ID**

12

**CIM Information**

Prefix: PLAT ID: 0490

**User Response**

1. Reduce the ambient temperature.
  2. Ensure the air baffle is installed correctly.
  3. Check the server airflow. Make sure that nothing is blocking the air from coming into or preventing the air from exiting the server.
- **80010701-1402ffff : Numeric sensor [NumericSensorElementName] going high (upper non-critical) has asserted. (CPU2 VR Temp)**

This message is for the use case when an implementation has detected an Upper Non-critical sensor going high has asserted.

May also be shown as 800107011402ffff or 0x800107011402ffff

**Severity**

Warning

**Serviceable**

Yes

**Automatically notify support**

No

**Alert Category**

Warning - Temperature

**SNMP Trap ID**

12

**CIM Information**

Prefix: PLAT ID: 0490

**User Response**

1. Reduce the ambient temperature.
  2. Ensure the air baffle is installed correctly.
  3. Check the server airflow. Make sure that nothing is blocking the air from coming into or preventing the air from exiting the server.
- **80010701-1403ffff : Numeric sensor [NumericSensorElementName] going high (upper non-critical) has asserted. (DIMM AB VR Temp)**

This message is for the use case when an implementation has detected an Upper Non-critical sensor going high has asserted.

May also be shown as 800107011403ffff or 0x800107011403ffff

**Severity**

Warning

**Serviceable**

Yes

**Automatically notify support**

No

**Alert Category**

Warning - Temperature

**SNMP Trap ID**

12

**CIM Information**

Prefix: PLAT ID: 0490

**User Response**

1. Reduce the ambient temperature.
  2. Ensure the air baffle is installed correctly.
  3. Check the server airflow. Make sure that nothing is blocking the air from coming into or preventing the air from exiting the server.
- **80010701-1404ffff : Numeric sensor [NumericSensorElementName] going high (upper non-critical) has asserted. (DIMM CD VR Temp)**

This message is for the use case when an implementation has detected an Upper Non-critical sensor going high has asserted.

May also be shown as 800107011404ffff or 0x800107011404ffff

**Severity**

Warning

**Serviceable**

Yes

**Automatically notify support**

No

**Alert Category**

Warning - Temperature

**SNMP Trap ID**

12

**CIM Information**

Prefix: PLAT ID: 0490

**User Response**

1. Reduce the ambient temperature.
  2. Ensure the air baffle is installed correctly.
  3. Check the server airflow. Make sure that nothing is blocking the air from coming into or preventing the air from exiting the server.
- **80010701-1405ffff : Numeric sensor [NumericSensorElementName] going high (upper non-critical) has asserted. (DIMM EF VR Temp)**

This message is for the use case when an implementation has detected an Upper Non-critical sensor going high has asserted.

May also be shown as 800107011405ffff or 0x800107011405ffff

**Severity**

Warning

**Serviceable**

Yes

**Automatically notify support**

No

**Alert Category**

Warning - Temperature

**SNMP Trap ID**

12

**CIM Information**

**Prefix:** PLAT ID: 0490

**User Response**

1. Reduce the ambient temperature.
  2. Ensure the air baffle is installed correctly.
  3. Check the server airflow. Make sure that nothing is blocking the air from coming into or preventing the air from exiting the server.
- **80010701-1406ffff : Numeric sensor [NumericSensorElementName] going high (upper non-critical) has asserted. (DIMM GH VR Temp)**

This message is for the use case when an implementation has detected an Upper Non-critical sensor going high has asserted.

May also be shown as 800107011406ffff or 0x800107011406ffff

**Severity**

Warning

**Serviceable**

Yes

**Automatically notify support**

No

**Alert Category**

Warning - Temperature

**SNMP Trap ID**

12

**CIM Information**

**Prefix:** PLAT ID: 0490

**User Response**

1. Make sure that the fans are operating, that there are no obstructions to the airflow (front and rear of the server), that the air baffle is in place and correctly installed, and that the server cover is installed and completely closed.
2. Check the ambient temperature. You must be operating within the specifications (see Server Features and specifications for more information).
3. Make sure that the heat sink for microprocessor n.

- 4. (Trained technician only) Replace system board.
- **80010701-2d01ffff : Numeric sensor [NumericSensorElementName] going high (upper non-critical) has asserted. (PCH Temp)**

This message is for the use case when an implementation has detected an Upper Non-critical sensor going high has asserted.

May also be shown as 800107012d01ffff or 0x800107012d01ffff

**Severity**

Warning

**Serviceable**

Yes

**Automatically notify support**

No

**Alert Category**

Warning - Temperature

**SNMP Trap ID**

12

**CIM Information**

**Prefix: PLAT ID:** 0490

**User Response**

1. Make sure that the fans are operating, that there are no obstructions to the airflow (front and rear of the server), that the air baffle is in place and correctly installed, and that the server cover is installed and completely closed.
  2. Check the ambient temperature. You must be operating within the specifications (see Server Features and specifications for more information).
  3. Make sure that the heat sink for microprocessor n.
  4. (Trained technician only) Replace system board.
- **80010701-3701ffff : Numeric sensor [NumericSensorElementName] going high (upper non-critical) has asserted. (Ambient Temp)**

This message is for the use case when an implementation has detected an Upper Non-critical sensor going high has asserted.

May also be shown as 800107013701ffff or 0x800107013701ffff

**Severity**

Warning

**Serviceable**

Yes

**Automatically notify support**

No

**Alert Category**

Warning - Temperature

**SNMP Trap ID**

12

**CIM Information**

**Prefix: PLAT ID:** 0490

**User Response**

1. Make sure that the fans are operating, that there are no obstructions to the airflow (front and rear of the server), that the air baffle is in place and correctly installed, and that the server cover is installed and completely closed.
  2. Check the ambient temperature. You must be operating within the specifications (see Server Features and specifications for more information).
  3. Make sure that the heat sink for microprocessor n.
  4. (Trained technician only) Replace system board.
- **80010901-0701ffff : Numeric sensor [NumericSensorElementName] going high (upper critical) has asserted. (RS1 RR Amb Temp)**

This message is for the use case when an implementation has detected an Upper Critical sensor going high has asserted.

May also be shown as 800109010701ffff or 0x800109010701ffff

**Severity**

Error

**Serviceable**

Yes

**Automatically notify support**

No

**Alert Category**

Critical - Temperature

**SNMP Trap ID**

0

**CIM Information**

**Prefix:** PLAT ID: 0494

**User Response**

1. Make sure that the fans are operating, that there are no obstructions to the airflow (front and rear of the server), that the air baffle is in place and correctly installed, and that the server cover is installed and completely closed.
  2. Check the ambient temperature. You must be operating within the specifications (see Server Features and specifications for more information).
  3. (Trained technician only) Replace system board.
- **80010901-0702ffff : Numeric sensor [NumericSensorElementName] going high (upper critical) has asserted. (RS2 RR Amb Temp)**

This message is for the use case when an implementation has detected an Upper Critical sensor going high has asserted.

May also be shown as 800109010702ffff or 0x800109010702ffff

**Severity**

Error

**Serviceable**

Yes

**Automatically notify support**

No

**Alert Category**

Critical - Temperature

**SNMP Trap ID**

0

**CIM Information**

Prefix: PLAT ID: 0494

**User Response**

1. Make sure that the fans are operating, that there are no obstructions to the airflow (front and rear of the server), that the air baffle is in place and correctly installed, and that the server cover is installed and completely closed.
  2. Check the ambient temperature. You must be operating within the specifications (see Server Features and specifications for more information).
  3. (Trained technician only) Replace system board.
- **80010901-0703ffff : Numeric sensor [NumericSensorElementName] going high (upper critical) has asserted. (MID1 RR Amb Temp)**

This message is for the use case when an implementation has detected an Upper Critical sensor going high has asserted.

May also be shown as 800109010703ffff or 0x800109010703ffff

**Severity**

Error

**Serviceable**

Yes

**Automatically notify support**

No

**Alert Category**

Critical - Temperature

**SNMP Trap ID**

0

**CIM Information**

Prefix: PLAT ID: 0494

**User Response**

1. Make sure that the fans are operating, that there are no obstructions to the airflow (front and rear of the server), that the air baffle is in place and correctly installed, and that the server cover is installed and completely closed.
  2. Check the ambient temperature. You must be operating within the specifications (see Server Features and specifications for more information).
  3. (Trained technician only) Replace system board.
- **80010901-0704ffff : Numeric sensor [NumericSensorElementName] going high (upper critical) has asserted. (MID2 RR Amb Temp)**

This message is for the use case when an implementation has detected an Upper Critical sensor going high has asserted.

May also be shown as 800109010704ffff or 0x800109010704ffff

**Severity**

Error

**Serviceable**

Yes

**Automatically notify support**

No

**Alert Category**

Critical - Temperature

**SNMP Trap ID**

0

**CIM Information**

**Prefix:** PLAT ID: 0494

**User Response**

1. Make sure that the fans are operating, that there are no obstructions to the airflow (front and rear of the server), that the air baffle is in place and correctly installed, and that the server cover is installed and completely closed.
  2. Check the ambient temperature. You must be operating within the specifications (see Server Features and specifications for more information).
  3. (Trained technician only) Replace system board.
- **80010901-0705ffff : Numeric sensor [NumericSensorElementName] going high (upper critical) has asserted. (RAID RR Amb Temp)**

This message is for the use case when an implementation has detected an Upper Critical sensor going high has asserted.

May also be shown as 800109010705ffff or 0x800109010705ffff

**Severity**

Error

**Serviceable**

Yes

**Automatically notify support**

No

**Alert Category**

Critical - Temperature

**SNMP Trap ID**

0

**CIM Information**

**Prefix:** PLAT ID: 0494

**User Response**

1. Make sure that the fans are operating, that there are no obstructions to the airflow (front and rear of the server), that the air baffle is in place and correctly installed, and that the server cover is installed and completely closed.
  2. Check the ambient temperature. You must be operating within the specifications (see Server Features and specifications for more information).
  3. (Trained technician only) Replace system board.
- **80010901-0706ffff : Numeric sensor [NumericSensorElementName] going high (upper critical) has asserted. (PSU FR Amb Temp)**

This message is for the use case when an implementation has detected an Upper Critical sensor going high has asserted.

May also be shown as 800109010706ffff or 0x800109010706ffff

**Severity**

Error

**Serviceable**

Yes

**Automatically notify support**

No

**Alert Category**

Critical - Temperature

**SNMP Trap ID**

0

**CIM Information**

**Prefix: PLAT ID:** 0494

**User Response**

1. Make sure that the fans are operating, that there are no obstructions to the airflow (front and rear of the server), that the air baffle is in place and correctly installed, and that the server cover is installed and completely closed.
  2. Check the ambient temperature. You must be operating within the specifications (see Server Features and specifications for more information).
  3. Replace power supply.
- **80010901-0707ffff : Numeric sensor [NumericSensorElementName] going high (upper critical) has asserted. (Rear BP1 Temp)**

This message is for the use case when an implementation has detected an Upper Critical sensor going high has asserted.

May also be shown as 800109010707ffff or 0x800109010707ffff

**Severity**

Error

**Serviceable**

Yes

**Automatically notify support**

No

**Alert Category**

Critical - Temperature

**SNMP Trap ID**

0

**CIM Information**

**Prefix: PLAT ID:** 0494

**User Response**

1. Make sure that the fans are operating, that there are no obstructions to the airflow (front and rear of the server), that the air baffle is in place and correctly installed, and that the server cover is installed and completely closed.
2. Check the ambient temperature. You must be operating within the specifications (see Server Features and specifications for more information).
3. Check fan cable on rear HDD cable is connected correctly.
4. Check the fans on rear HDD cage are functional.



- 5. Replace rear HDD drive cage.
- **80010901-0708ffff : Numeric sensor [NumericSensorElementName] going high (upper critical) has asserted. (Rear BP2 Temp)**

This message is for the use case when an implementation has detected an Upper Critical sensor going high has asserted.

May also be shown as 800109010708ffff or 0x800109010708ffff

**Severity**

Error

**Serviceable**

Yes

**Automatically notify support**

No

**Alert Category**

Critical - Temperature

**SNMP Trap ID**

0

**CIM Information**

**Prefix:** PLAT ID: 0494

**User Response**

1. Make sure that the fans are operating, that there are no obstructions to the airflow (front and rear of the server), that the air baffle is in place and correctly installed, and that the server cover is installed and completely closed.
  2. Check the ambient temperature. You must be operating within the specifications (see Server Features and specifications for more information).
  3. Check fan cable on rear HDD cable is connected correctly.
  4. Check the fans on rear HDD cage are functional.
  5. Replace rear HDD drive cage.
- **80010901-1401ffff : Numeric sensor [NumericSensorElementName] going high (upper critical) has asserted. (CPU1 VR Temp)**

This message is for the use case when an implementation has detected an Upper Critical sensor going high has asserted.

May also be shown as 800109011401ffff or 0x800109011401ffff

**Severity**

Error

**Serviceable**

Yes

**Automatically notify support**

No

**Alert Category**

Critical - Temperature

**SNMP Trap ID**

0

**CIM Information**

**Prefix:** PLAT ID: 0494

### User Response

1. Reduce the ambient temperature.
  2. Ensure the air baffle is installed correctly.
  3. Check the server airflow. Make sure that nothing is blocking the air from coming into or preventing the air from exiting the server.
- **80010901-1402ffff : Numeric sensor [NumericSensorElementName] going high (upper critical) has asserted. (CPU2 VR Temp)**

This message is for the use case when an implementation has detected an Upper Critical sensor going high has asserted.

May also be shown as 800109011402ffff or 0x800109011402ffff

### Severity

Error

### Serviceable

Yes

### Automatically notify support

No

### Alert Category

Critical - Temperature

### SNMP Trap ID

0

### CIM Information

Prefix: PLAT ID: 0494

### User Response

1. Reduce the ambient temperature.
  2. Ensure the air baffle is installed correctly.
  3. Check the server airflow. Make sure that nothing is blocking the air from coming into or preventing the air from exiting the server.
- **80010901-1403ffff : Numeric sensor [NumericSensorElementName] going high (upper critical) has asserted. (DIMM AB VR Temp)**

This message is for the use case when an implementation has detected an Upper Critical sensor going high has asserted.

May also be shown as 800109011403ffff or 0x800109011403ffff

### Severity

Error

### Serviceable

Yes

### Automatically notify support

No

### Alert Category

Critical - Temperature

### SNMP Trap ID

0

### CIM Information

Prefix: PLAT ID: 0494

**User Response**

1. Reduce the ambient temperature.
  2. Ensure the air baffle is installed correctly.
  3. Check the server airflow. Make sure that nothing is blocking the air from coming into or preventing the air from exiting the server.
- **80010901-1404ffff : Numeric sensor [NumericSensorElementName] going high (upper critical) has asserted. (DIMM CD VR Temp)**

This message is for the use case when an implementation has detected an Upper Critical sensor going high has asserted.

May also be shown as 800109011404ffff or 0x800109011404ffff

**Severity**

Error

**Serviceable**

Yes

**Automatically notify support**

No

**Alert Category**

Critical - Temperature

**SNMP Trap ID**

0

**CIM Information**

**Prefix:** PLAT ID: 0494

**User Response**

1. Reduce the ambient temperature.
  2. Ensure the air baffle is installed correctly.
  3. Check the server airflow. Make sure that nothing is blocking the air from coming into or preventing the air from exiting the server.
- **80010901-1405ffff : Numeric sensor [NumericSensorElementName] going high (upper critical) has asserted. (DIMM EF VR Temp)**

This message is for the use case when an implementation has detected an Upper Critical sensor going high has asserted.

May also be shown as 800109011405ffff or 0x800109011405ffff

**Severity**

Error

**Serviceable**

Yes

**Automatically notify support**

No

**Alert Category**

Critical - Temperature

**SNMP Trap ID**

0

**CIM Information**

**Prefix:** PLAT ID: 0494

### User Response

1. Reduce the ambient temperature.
  2. Ensure the air baffle is installed correctly.
  3. Check the server airflow. Make sure that nothing is blocking the air from coming into or preventing the air from exiting the server.
- **80010901-1406ffff : Numeric sensor [NumericSensorElementName] going high (upper critical) has asserted. (DIMM GH VR Temp)**

This message is for the use case when an implementation has detected an Upper Critical sensor going high has asserted.

May also be shown as 800109011406ffff or 0x800109011406ffff

### Severity

Error

### Serviceable

Yes

### Automatically notify support

No

### Alert Category

Critical - Temperature

### SNMP Trap ID

0

### CIM Information

Prefix: PLAT ID: 0494

### User Response

1. Make sure that the fans are operating, that there are no obstructions to the airflow (front and rear of the server), that the air baffle is in place and correctly installed, and that the server cover is installed and completely closed.
  2. Check the ambient temperature. You must be operating within the specifications (see Server Features and specifications for more information).
  3. Make sure that the heat sink for microprocessor n.
  4. (Trained technician only) Replace system board.
- **80010901-2d01ffff : Numeric sensor [NumericSensorElementName] going high (upper critical) has asserted. (PCH Temp)**

This message is for the use case when an implementation has detected an Upper Critical sensor going high has asserted.

May also be shown as 800109012d01ffff or 0x800109012d01ffff

### Severity

Error

### Serviceable

Yes

### Automatically notify support

No

### Alert Category

Critical - Temperature

### SNMP Trap ID

0

#### **CIM Information**

**Prefix:** PLAT ID: 0494

#### **User Response**

1. Make sure that the fans are operating, that there are no obstructions to the airflow (front and rear of the server), that the air baffle is in place and correctly installed, and that the server cover is installed and completely closed.
  2. Check the ambient temperature. You must be operating within the specifications (see Server Features and specifications for more information).
  3. Make sure that the heat sink for microprocessor n.
  4. (Trained technician only) Replace system board.
- **80010901-3701ffff : Numeric sensor [NumericSensorElementName] going high (upper critical) has asserted. (Ambient Temp)**

This message is for the use case when an implementation has detected an Upper Critical sensor going high has asserted.

May also be shown as 800109013701ffff or 0x800109013701ffff

#### **Severity**

Error

#### **Serviceable**

Yes

#### **Automatically notify support**

No

#### **Alert Category**

Critical - Temperature

#### **SNMP Trap ID**

0

#### **CIM Information**

**Prefix:** PLAT ID: 0494

#### **User Response**

1. Make sure that the fans are operating, that there are no obstructions to the airflow (front and rear of the server), that the air baffle is in place and correctly installed, and that the server cover is installed and completely closed.
  2. Check the ambient temperature. You must be operating within the specifications (see Server Features and specifications for more information).
  3. Make sure that the heat sink for microprocessor n.
  4. (Trained technician only) Replace system board.
- **80010902-0701ffff : Numeric sensor [NumericSensorElementName] going high (upper critical) has asserted. (SysBrd 12V)**

This message is for the use case when an implementation has detected an Upper Critical sensor going high has asserted.

May also be shown as 800109020701ffff or 0x800109020701ffff

#### **Severity**

Error

#### **Serviceable**

Yes

**Automatically notify support**

Yes

**Alert Category**

Critical - Voltage

**SNMP Trap ID**

1

**CIM Information**

Prefix: PLAT ID: 0494

**User Response**

If the specified sensor is Planar 3.3V or Planar 5V, (Trained technician only) replace the system board.

If the specified sensor is Planar 12V, complete the following steps until the problem is solved:

1. Check power supply n LED.
2. Remove the failing power supply.
3. (Trained technician only) Replace the system board. (n = power supply number)

SysBrd 3.3V : SysBrd 5V :

- **80010b01-0701ffff : Numeric sensor [NumericSensorElementName] going high (upper non-recoverable) has asserted. (RS1 RR Amb Temp)**

This message is for the use case when an implementation has detected an Upper Non-recoverable sensor going high has asserted.

May also be shown as 80010b010701ffff or 0x80010b010701ffff

**Severity**

Error

**Serviceable**

Yes

**Automatically notify support**

No

**Alert Category**

Critical - Temperature

**SNMP Trap ID**

0

**CIM Information**

Prefix: PLAT ID: 0498

**User Response**

1. Make sure that the fans are operating, that there are no obstructions to the airflow (front and rear of the server), that the air baffle is in place and correctly installed, and that the server cover is installed and completely closed.
  2. Check the ambient temperature. You must be operating within the specifications (see Server Features and specifications for more information).
  3. Make sure that the heat sink for microprocessor n.
  4. (Trained technician only) Replace system board.
- **80010b01-0702ffff : Numeric sensor [NumericSensorElementName] going high (upper non-recoverable) has asserted. (RS2 RR Amb Temp)**

This message is for the use case when an implementation has detected an Upper Non-recoverable sensor going high has asserted.

May also be shown as 80010b010702ffff or 0x80010b010702ffff

**Severity**

Error

**Serviceable**

Yes

**Automatically notify support**

No

**Alert Category**

Critical - Temperature

**SNMP Trap ID**

0

**CIM Information**

**Prefix:** PLAT ID: 0498

**User Response**

1. Make sure that the fans are operating, that there are no obstructions to the airflow (front and rear of the server), that the air baffle is in place and correctly installed, and that the server cover is installed and completely closed.
  2. Check the ambient temperature. You must be operating within the specifications (see Server Features and specifications for more information).
  3. Make sure that the heat sink for microprocessor n.
  4. (Trained technician only) Replace system board.
- **80010b01-0703ffff : Numeric sensor [NumericSensorElementName] going high (upper non-recoverable) has asserted. (MID1 RR Amb Temp)**

This message is for the use case when an implementation has detected an Upper Non-recoverable sensor going high has asserted.

May also be shown as 80010b010703ffff or 0x80010b010703ffff

**Severity**

Error

**Serviceable**

Yes

**Automatically notify support**

No

**Alert Category**

Critical - Temperature

**SNMP Trap ID**

0

**CIM Information**

**Prefix:** PLAT ID: 0498

**User Response**

1. Make sure that the fans are operating, that there are no obstructions to the airflow (front and rear of the server), that the air baffle is in place and correctly installed, and that the server cover is installed and completely closed.

2. Check the ambient temperature. You must be operating within the specifications (see Server Features and specifications for more information).
  3. Make sure that the heat sink for microprocessor n.
  4. (Trained technician only) Replace system board.
- **80010b01-0704ffff : Numeric sensor [NumericSensorElementName] going high (upper non-recoverable) has asserted. (MID2 RR Amb Temp)**

This message is for the use case when an implementation has detected an Upper Non-recoverable sensor going high has asserted.

May also be shown as 80010b010704ffff or 0x80010b010704ffff

**Severity**

Error

**Serviceable**

Yes

**Automatically notify support**

No

**Alert Category**

Critical - Temperature

**SNMP Trap ID**

0

**CIM Information**

**Prefix: PLAT ID: 0498**

**User Response**

1. Make sure that the fans are operating, that there are no obstructions to the airflow (front and rear of the server), that the air baffle is in place and correctly installed, and that the server cover is installed and completely closed.
  2. Check the ambient temperature. You must be operating within the specifications (see Server Features and specifications for more information).
  3. Make sure that the heat sink for microprocessor n.
  4. (Trained technician only) Replace system board.
- **80010b01-0705ffff : Numeric sensor [NumericSensorElementName] going high (upper non-recoverable) has asserted. (RAID RR Amb Temp)**

This message is for the use case when an implementation has detected an Upper Non-recoverable sensor going high has asserted.

May also be shown as 80010b010705ffff or 0x80010b010705ffff

**Severity**

Error

**Serviceable**

Yes

**Automatically notify support**

No

**Alert Category**

Critical - Temperature

**SNMP Trap ID**

0



## CIM Information

Prefix: PLAT ID: 0498

## User Response

1. Make sure that the fans are operating, that there are no obstructions to the airflow (front and rear of the server), that the air baffle is in place and correctly installed, and that the server cover is installed and completely closed.
  2. Check the ambient temperature. You must be operating within the specifications (see Server Features and specifications for more information).
  3. Make sure that the heat sink for microprocessor n.
  4. (Trained technician only) Replace system board.
- **80010b01-0706ffff : Numeric sensor [NumericSensorElementName] going high (upper non-recoverable) has asserted. (PSU FR Amb Temp)**

This message is for the use case when an implementation has detected an Upper Non-recoverable sensor going high has asserted.

May also be shown as 80010b010706ffff or 0x80010b010706ffff

## Severity

Error

## Serviceable

Yes

## Automatically notify support

No

## Alert Category

Critical - Temperature

## SNMP Trap ID

0

## CIM Information

Prefix: PLAT ID: 0498

## User Response

1. Make sure that the fans are operating, that there are no obstructions to the airflow (front and rear of the server), that the air baffle is in place and correctly installed, and that the server cover is installed and completely closed.
  2. Check the ambient temperature. You must be operating within the specifications (see Server Features and specifications for more information).
  3. Make sure that the heat sink for microprocessor n.
  4. (Trained technician only) Replace system board.
- **80010b01-0707ffff : Numeric sensor [NumericSensorElementName] going high (upper non-recoverable) has asserted. (Rear BP1 Temp)**

This message is for the use case when an implementation has detected an Upper Non-recoverable sensor going high has asserted.

May also be shown as 80010b010707ffff or 0x80010b010707ffff

## Severity

Error

## Serviceable

Yes

**Automatically notify support**

No

**Alert Category**

Critical - Temperature

**SNMP Trap ID**

0

**CIM Information**

Prefix: PLAT ID: 0498

**User Response**

1. Make sure that the fans are operating, that there are no obstructions to the airflow (front and rear of the server), that the air baffle is in place and correctly installed, and that the server cover is installed and completely closed.
  2. Check the ambient temperature. You must be operating within the specifications (see Server Features and specifications for more information).
  3. Check fan cable on rear HDD cable is connected correctly.
  4. Check the fans on rear HDD cage are functional.
  5. Replace rear HDD drive cage.
- **80010b01-0708ffff : Numeric sensor [NumericSensorElementName] going high (upper non-recoverable) has asserted. (Rear BP2 Temp)**

This message is for the use case when an implementation has detected an Upper Non-recoverable sensor going high has asserted.

May also be shown as 80010b010708ffff or 0x80010b010708ffff

**Severity**

Error

**Serviceable**

Yes

**Automatically notify support**

No

**Alert Category**

Critical - Temperature

**SNMP Trap ID**

0

**CIM Information**

Prefix: PLAT ID: 0498

**User Response**

1. Make sure that the fans are operating, that there are no obstructions to the airflow (front and rear of the server), that the air baffle is in place and correctly installed, and that the server cover is installed and completely closed.
  2. Check the ambient temperature. You must be operating within the specifications (see Server Features and specifications for more information).
  3. Check fan cable on rear HDD cable is connected correctly.
  4. Check the fans on rear HDD cage are functional.
  5. Replace rear HDD drive cage.
- **80010b01-1401ffff : Numeric sensor [NumericSensorElementName] going high (upper non-recoverable) has asserted. (CPU1 VR Temp)**

This message is for the use case when an implementation has detected an Upper Non-recoverable sensor going high has asserted.

May also be shown as 80010b011401ffff or 0x80010b011401ffff

**Severity**

Error

**Serviceable**

Yes

**Automatically notify support**

No

**Alert Category**

Critical - Temperature

**SNMP Trap ID**

0

**CIM Information**

Prefix: PLAT ID: 0498

**User Response**

1. Make sure that the fans are operating, that there are no obstructions to the airflow (front and rear of the server), that the air baffle is in place and correctly installed, and that the server cover is installed and completely closed.
  2. Check the ambient temperature. You must be operating within the specifications (see Server Features and specifications for more information).
  3. Make sure that the heat sink for microprocessor n.
  4. (Trained technician only) Replace system board.
- **80010b01-1402ffff : Numeric sensor [NumericSensorElementName] going high (upper non-recoverable) has asserted. (CPU2 VR Temp)**

This message is for the use case when an implementation has detected an Upper Non-recoverable sensor going high has asserted.

May also be shown as 80010b011402ffff or 0x80010b011402ffff

**Severity**

Error

**Serviceable**

Yes

**Automatically notify support**

No

**Alert Category**

Critical - Temperature

**SNMP Trap ID**

0

**CIM Information**

Prefix: PLAT ID: 0498

**User Response**

1. Make sure that the fans are operating, that there are no obstructions to the airflow (front and rear of the server), that the air baffle is in place and correctly installed, and that the server cover is installed and completely closed.

2. Check the ambient temperature. You must be operating within the specifications (see Server Features and specifications for more information).
  3. Make sure that the heat sink for microprocessor n.
  4. (Trained technician only) Replace system board.
- **80010b01-1403ffff : Numeric sensor [NumericSensorElementName] going high (upper non-recoverable) has asserted. (DIMM AB VR Temp)**

This message is for the use case when an implementation has detected an Upper Non-recoverable sensor going high has asserted.

May also be shown as 80010b011403ffff or 0x80010b011403ffff

**Severity**

Error

**Serviceable**

Yes

**Automatically notify support**

No

**Alert Category**

Critical - Temperature

**SNMP Trap ID**

0

**CIM Information**

**Prefix: PLAT ID: 0498**

**User Response**

1. Make sure that the fans are operating, that there are no obstructions to the airflow (front and rear of the server), that the air baffle is in place and correctly installed, and that the server cover is installed and completely closed.
  2. Check the ambient temperature. You must be operating within the specifications (see Server Features and specifications for more information).
  3. Make sure that the heat sink for microprocessor n.
  4. (Trained technician only) Replace system board.
- **80010b01-1404ffff : Numeric sensor [NumericSensorElementName] going high (upper non-recoverable) has asserted. (DIMM CD VR Temp)**

This message is for the use case when an implementation has detected an Upper Non-recoverable sensor going high has asserted.

May also be shown as 80010b011404ffff or 0x80010b011404ffff

**Severity**

Error

**Serviceable**

Yes

**Automatically notify support**

No

**Alert Category**

Critical - Temperature

**SNMP Trap ID**

0

**CIM Information**

Prefix: PLAT ID: 0498

**User Response**

1. Make sure that the fans are operating, that there are no obstructions to the airflow (front and rear of the server), that the air baffle is in place and correctly installed, and that the server cover is installed and completely closed.
  2. Check the ambient temperature. You must be operating within the specifications (see Server Features and specifications for more information).
  3. Make sure that the heat sink for microprocessor n.
  4. (Trained technician only) Replace system board.
- **80010b01-1405ffff : Numeric sensor [NumericSensorElementName] going high (upper non-recoverable) has asserted. (DIMM EF VR Temp)**

This message is for the use case when an implementation has detected an Upper Non-recoverable sensor going high has asserted.

May also be shown as 80010b011405ffff or 0x80010b011405ffff

**Severity**

Error

**Serviceable**

Yes

**Automatically notify support**

No

**Alert Category**

Critical - Temperature

**SNMP Trap ID**

0

**CIM Information**

Prefix: PLAT ID: 0498

**User Response**

1. Make sure that the fans are operating, that there are no obstructions to the airflow (front and rear of the server), that the air baffle is in place and correctly installed, and that the server cover is installed and completely closed.
  2. Check the ambient temperature. You must be operating within the specifications (see Server Features and specifications for more information).
  3. Make sure that the heat sink for microprocessor n.
  4. (Trained technician only) Replace system board.
- **80010b01-1406ffff : Numeric sensor [NumericSensorElementName] going high (upper non-recoverable) has asserted. (DIMM GH VR Temp)**

This message is for the use case when an implementation has detected an Upper Non-recoverable sensor going high has asserted.

May also be shown as 80010b011406ffff or 0x80010b011406ffff

**Severity**

Error

**Serviceable**

Yes

**Automatically notify support**

No

**Alert Category**

Critical - Temperature

**SNMP Trap ID**

0

**CIM Information**

Prefix: PLAT ID: 0498

**User Response**

1. Make sure that the fans are operating, that there are no obstructions to the airflow (front and rear of the server), that the air baffle is in place and correctly installed, and that the server cover is installed and completely closed.
  2. Check the ambient temperature. You must be operating within the specifications (see Server Features and specifications for more information).
  3. Make sure that the heat sink for microprocessor n.
  4. (Trained technician only) Replace system board.
- **80010b01-2d01ffff : Numeric sensor [NumericSensorElementName] going high (upper non-recoverable) has asserted. (PCH Temp)**

This message is for the use case when an implementation has detected an Upper Non-recoverable sensor going high has asserted.

May also be shown as 80010b012d01ffff or 0x80010b012d01ffff

**Severity**

Error

**Serviceable**

Yes

**Automatically notify support**

No

**Alert Category**

Critical - Temperature

**SNMP Trap ID**

0

**CIM Information**

Prefix: PLAT ID: 0498

**User Response**

1. Make sure that the fans are operating, that there are no obstructions to the airflow (front and rear of the server), that the air baffle is in place and correctly installed, and that the server cover is installed and completely closed.
  2. Check the ambient temperature. You must be operating within the specifications (see Server Features and specifications for more information).
  3. Make sure that the heat sink for microprocessor n.
  4. (Trained technician only) Replace system board.
- **80010b01-3701ffff : Numeric sensor [NumericSensorElementName] going high (upper non-recoverable) has asserted. (Ambient Temp)**

This message is for the use case when an implementation has detected an Upper Non-recoverable sensor going high has asserted.

May also be shown as 80010b013701ffff or 0x80010b013701ffff

**Severity**

Error

**Serviceable**

Yes

**Automatically notify support**

No

**Alert Category**

Critical - Temperature

**SNMP Trap ID**

0

**CIM Information**

**Prefix: PLAT ID:** 0498

**User Response**

1. Check operator informationpanel cable is connected.
  2. Check the ambient temperature. You must be operating within the specifications (see Server Features and specifications for more information).
  3. Replace operator information cable or usb assembly cable.
  4. (Trained technician only) Replace system board.
- **80030006-2101ffff : Sensor [SensorElementName] has deasserted. (Sig Verify Fail)**

This message is for the use case when an implementation has detected a Sensor has deasserted.

May also be shown as 800300062101ffff or 0x800300062101ffff

**Severity**

Info

**Serviceable**

No

**Automatically notify support**

No

**Alert Category**

System - Other

**SNMP Trap ID**

**CIM Information**

**Prefix: PLAT ID:** 0509

**User Response**

No action; information only.

- **80030012-2301ffff : Sensor [SensorElementName] has deasserted. (OS RealTime Mod)**

This message is for the use case when an implementation has detected a Sensor has deasserted.

May also be shown as 800300122301ffff or 0x800300122301ffff

**Severity**

Info

**Serviceable**

No

**Automatically notify support**

No

**Alert Category**

System - Other

**SNMP Trap ID****CIM Information**

Prefix: PLAT ID: 0509

**User Response**

No action; information only.

- **80030021-0782ffff : Sensor [SensorElementName] has deasserted. (PCIe Dev LK Down)**

This message is for the use case when an implementation has detected a Sensor has deasserted.

May also be shown as 800300210782ffff or 0x800300210782ffff

**Severity**

Info

**Serviceable**

No

**Automatically notify support**

No

**Alert Category**

System - Other

**SNMP Trap ID****CIM Information**

Prefix: PLAT ID: 0509

**User Response**

No action; information only.

- **80030108-1301ffff : Sensor [SensorElementName] has asserted. (PS Heavy Load)**

This message is for the use case when an implementation has detected a Sensor has asserted.

May also be shown as 800301081301ffff or 0x800301081301ffff

**Severity**

Info

**Serviceable**

No

**Automatically notify support**

No

**Alert Category**

System - Other

**SNMP Trap ID****CIM Information**

Prefix: PLAT ID: 0508

**User Response**



1. Replace the power supply with higher rated power.
2. Reduce the total power consumption by removing newly added or unused option like drives or adapters.

- **8003010c-2581ffff : Sensor [SensorElementName] has asserted. (Non-Auth DIMMs)**

This message is for the use case when an implementation has detected a Sensor has asserted.

May also be shown as 8003010c2581ffff or 0x8003010c2581ffff

**Severity**

Info

**Serviceable**

No

**Automatically notify support**

No

**Alert Category**

System - Other

**SNMP Trap ID**

**CIM Information**

**Prefix:** PLAT ID: 0508

**User Response**

1. Replace as authorized DIMM.
2. Please contact sales representative or Lenovo support.

- **8003010f-2101ffff : Sensor [SensorElementName] has asserted. (IMM FW Corrupted)**

This message is for the use case when an implementation has detected a Sensor has asserted.

May also be shown as 8003010f2101ffff or 0x8003010f2101ffff

**Severity**

Info

**Serviceable**

No

**Automatically notify support**

No

**Alert Category**

System - Other

**SNMP Trap ID**

**CIM Information**

**Prefix:** PLAT ID: 0508

**User Response**

1. Reflash primary code.
2. Disconnect power cord and reconnect.
3. (Trained technician only) please replace system board if the problem still exist.

- **80030112-0601ffff : Sensor [SensorElementName] has asserted. (SMM Mode)**

This message is for the use case when an implementation has detected a Sensor has asserted.

May also be shown as 800301120601ffff or 0x800301120601ffff

**Severity**

Info

**Serviceable**

No

**Automatically notify support**

No

**Alert Category**

System - Other

**SNMP Trap ID****CIM Information**

Prefix: PLAT ID: 0508

**User Response**

1. Replace the power supply with higher rated power.
2. Reduce the total power consumption by removing newly added or unused option like drives or adapters.

SMM Monitor :

- **80030121-0782ffff : Sensor [SensorElementName] has asserted. (PCIe Dev LK Down)**

This message is for the use case when an implementation has detected a Sensor has asserted.

May also be shown as 800301210782ffff or 0x800301210782ffff

**Severity**

Info

**Serviceable**

No

**Automatically notify support**

No

**Alert Category**

System - Other

**SNMP Trap ID****CIM Information**

Prefix: PLAT ID: 0508

**User Response**

1. Replace the power supply with higher rated power.
2. Reduce the total power consumption by removing newly added or unused option like drives or adapters.

- **8007000d-2582ffff : Sensor [SensorElementName] has transitioned to normal state. (RAID Vol State)**

This message is for the use case when an implementation has detected a Sensor transition to the normal state.

May also be shown as 8007000d2582ffff or 0x8007000d2582ffff

**Severity**

Info

**Serviceable**

No

**Automatically notify support**

No

**Alert Category**

Warning - Other

**SNMP Trap ID**

60

**CIM Information**

**Prefix:** PLAT ID: 0518

**User Response**

No action; information only.

- **80070101-0c01ffff : Sensor [SensorElementName] has transitioned from normal to non-critical state. (Ambient Status)**

This message is for the use case when an implementation has detected a Sensor transitioned to non-critical from normal.

May also be shown as 800701010c01ffff or 0x800701010c01ffff

**Severity**

Warning

**Serviceable**

Yes

**Automatically notify support**

No

**Alert Category**

Warning - Temperature

**SNMP Trap ID**

12

**CIM Information**

**Prefix:** PLAT ID: 0520

**User Response**

1. Check the microprocessor installed is Intel E5-2690.
2. Reduce the ambient temperature under 27 Celsius degree.

- **80070101-2c01ffff : Sensor [SensorElementName] has transitioned from normal to non-critical state. (ML2 OverTemp)**

This message is for the use case when an implementation has detected a Sensor transitioned to non-critical from normal.

May also be shown as 800701012c01ffff or 0x800701012c01ffff

**Severity**

Warning

**Serviceable**

Yes

**Automatically notify support**

No

**Alert Category**

Warning - Temperature

**SNMP Trap ID**

12

**CIM Information**

**Prefix:** PLAT ID: 0520

**User Response**

1. Make sure that the fans are operating, that there are no obstructions to the airflow (front and rear of the server), that the air baffle is in place and correctly installed, and that the server cover is installed and completely closed.
  2. Check the ambient temperature. You must be operating within the specifications (see Server Features and specifications for more information).
  3. Replace the failed ML2 card.
- **8007010d-2582ffff : Sensor [SensorElementName] has transitioned from normal to non-critical state. (RAID Vol State)**

This message is for the use case when an implementation has detected a Sensor transitioned to non-critical from normal.

May also be shown as 8007010d2582ffff or 0x8007010d2582ffff

**Severity**

Warning

**Serviceable**

Yes

**Automatically notify support**

No

**Alert Category**

Warning - Other

**SNMP Trap ID**

60

**CIM Information**

**Prefix:** PLAT ID: 0520

**User Response**

1. Run the hard disk drive diagnostic test on drive n.
  2. Reseat the following components: a. Hard disk drive (wait 1 minute or more before reinstalling the drive) b. Cable from the system board to the backplane
  3. Replace the following components one at a time, in the order shown, restarting the server each time: a. Hard disk drive b. Cable from the system board to the backplane c. Hard disk drive backplane (n = hard disk drive number)
- **8007010f-2201ffff : Sensor [SensorElementName] has transitioned from normal to non-critical state. (GPT Status)**

This message is for the use case when an implementation has detected a Sensor transitioned to non-critical from normal.

May also be shown as 8007010f2201ffff or 0x8007010f2201ffff

**Severity**

Warning

**Serviceable**

Yes

**Automatically notify support**

No

**Alert Category**

Warning - Other

**SNMP Trap ID**

60

**CIM Information**

**Prefix:** PLAT ID: 0520

**User Response**

1. Check the Lenovo support site for service bulletins or firmware updates that apply to this GPT error.
  2. Set the UEFI setting DISK GPT Recovery to Automatic.
  3. Replace the corrupt disk.
- **8007010f-2582ffff : Sensor [SensorElementName] has transitioned from normal to non-critical state. (I/O Resources)**

This message is for the use case when an implementation has detected a Sensor transitioned to non-critical from normal.

May also be shown as 8007010f2582ffff or 0x8007010f2582ffff

**Severity**

Warning

**Serviceable**

Yes

**Automatically notify support**

No

**Alert Category**

Warning - Other

**SNMP Trap ID**

60

**CIM Information**

**Prefix:** PLAT ID: 0520

**User Response**

Complete the following step to solve PCI I/O resource errors:

1. Go to F1 Setup
  2. System Settings
  3. Device and I/O ports
  4. PCI 64 bit Resource and choose enable
- **80070114-2201ffff : Sensor [SensorElementName] has transitioned from normal to non-critical state. (TPM Phy Pres Set)**

This message is for the use case when an implementation has detected a Sensor transitioned to non-critical from normal.

May also be shown as 800701142201ffff or 0x800701142201ffff

**Severity**

Warning

**Serviceable**

Yes

**Automatically notify support**

No

**Alert Category**

Warning - Other

**SNMP Trap ID**

60

**CIM Information**

**Prefix: PLAT ID:** 0520

**User Response**

1. Complete the administrative tasks that require the TPM physical presence switch to be in the ON position.
  2. Restore the physical presence switch to the OFF position.
  3. Reboot the system.
  4. (Trained technician only) If the error continues, replace the planar.
- **80070125-2583ffff : Sensor [SensorElementName] has transitioned from normal to non-critical state. (X8 PCI 1 Config)**

This message is for the use case when an implementation has detected a Sensor transitioned to non-critical from normal.

May also be shown as 800701252583ffff or 0x800701252583ffff

**Severity**

Warning

**Serviceable**

Yes

**Automatically notify support**

No

**Alert Category**

Warning - Other

**SNMP Trap ID**

60

**CIM Information**

**Prefix: PLAT ID:** 0520

**User Response**

None X8 PCI 2 Config : X8 PCI 6 Config : X8 PCI 7 Config :

- **80070128-2e01ffff : Sensor [SensorElementName] has transitioned from normal to non-critical state. (ME Recovery)**

This message is for the use case when an implementation has detected a Sensor transitioned to non-critical from normal.

May also be shown as 800701282e01ffff or 0x800701282e01ffff

**Severity**

Warning

**Serviceable**

Yes

**Automatically notify support**

No

**Alert Category**

Warning - Other

**SNMP Trap ID**

**CIM Information**

**Prefix:** PLAT ID: 0520

**User Response**

1. Restart IMM. If the error doesn't disappear, please proceed step 2.
  2. Update to the latest level of IMM/uEFI code, please proceed step 3.
  3. Replace node.
- **80070201-0301ffff : Sensor [SensorElementName] has transitioned to critical from a less severe state. (CPU 1 OverTemp)**

This message is for the use case when an implementation has detected a Sensor transitioned to critical from less severe.

May also be shown as 800702010301ffff or 0x800702010301ffff

**Severity**

Error

**Serviceable**

Yes

**Automatically notify support**

No

**Alert Category**

Critical - Temperature

**SNMP Trap ID**

0

**CIM Information**

**Prefix:** PLAT ID: 0522

**User Response**

1. Make sure that the fans are operating, that there are no obstructions to the airflow (front and rear of the server), that the air baffles are in place and correctly installed, and that the server cover is installed and completely closed.
  2. Check the ambient temperature. You must be operating within the specifications (see Features and specifications for more information).
  3. Make sure that the heat sink for microprocessor n is installed correctly.
  4. (Trained technician only) Replace microprocessor n. (n = microprocessor number)
- **80070201-0302ffff : Sensor [SensorElementName] has transitioned to critical from a less severe state. (CPU 2 OverTemp)**

This message is for the use case when an implementation has detected a Sensor transitioned to critical from less severe.

May also be shown as 800702010302ffff or 0x800702010302ffff

**Severity**

Error

**Serviceable**

Yes

**Automatically notify support**

No

**Alert Category**

Critical - Temperature

**SNMP Trap ID**

0

**CIM Information****Prefix: PLAT ID:** 0522**User Response**

1. Make sure that the fans are operating, that there are no obstructions to the airflow (front and rear of the server), that the air baffles are in place and correctly installed, and that the server cover is installed and completely closed.
  2. Check the ambient temperature. You must be operating within the specifications (see Features and specifications for more information).
  3. Make sure that the heat sink for microprocessor n is installed correctly.
  4. (Trained technician only) Replace microprocessor n. (n = microprocessor number)
- **80070201-1101ffff : Sensor [SensorElementName] has transitioned to critical from a less severe state. (PCI 1 Temp)**

This message is for the use case when an implementation has detected a Sensor transitioned to critical from less severe.

May also be shown as 800702011101ffff or 0x800702011101ffff

**Severity**

Error

**Serviceable**

Yes

**Automatically notify support**

No

**Alert Category**

Critical - Temperature

**SNMP Trap ID**

0

**CIM Information****Prefix: PLAT ID:** 0522**User Response**

1. Make sure that the fans are operating, that there are no obstructions to the airflow (front and rear of the server), that the air baffles are in place and correctly installed, and that the server cover is installed and completely closed.
2. Check the ambient temperature. You must be operating within the specifications (see Features and specifications for more information).
3. Make sure that the heat sink for microprocessor n is installed correctly.



4. (Trained technician only) Replace microprocessor n. (n = microprocessor number)
- **80070201-1102ffff : Sensor [SensorElementName] has transitioned to critical from a less severe state. (PCI 2 Temp)**

This message is for the use case when an implementation has detected a Sensor transitioned to critical from less severe.

May also be shown as 800702011102ffff or 0x800702011102ffff

**Severity**

Error

**Serviceable**

Yes

**Automatically notify support**

No

**Alert Category**

Critical - Temperature

**SNMP Trap ID**

0

**CIM Information**

**Prefix:** PLAT ID: 0522

**User Response**

1. Make sure that the fans are operating, that there are no obstructions to the airflow (front and rear of the server), that the air baffles are in place and correctly installed, and that the server cover is installed and completely closed.
  2. Check the ambient temperature. You must be operating within the specifications (see Features and specifications for more information).
  3. Make sure that the heat sink for microprocessor n is installed correctly.
  4. (Trained technician only) Replace microprocessor n. (n = microprocessor number)
- **80070201-1103ffff : Sensor [SensorElementName] has transitioned to critical from a less severe state. (PCI 3 Temp)**

This message is for the use case when an implementation has detected a Sensor transitioned to critical from less severe.

May also be shown as 800702011103ffff or 0x800702011103ffff

**Severity**

Error

**Serviceable**

Yes

**Automatically notify support**

No

**Alert Category**

Critical - Temperature

**SNMP Trap ID**

0

**CIM Information**

**Prefix:** PLAT ID: 0522

**User Response**

1. Make sure that the fans are operating, that there are no obstructions to the airflow (front and rear of the server), that the air baffles are in place and correctly installed, and that the server cover is installed and completely closed.
  2. Check the ambient temperature. You must be operating within the specifications (see Features and specifications for more information).
  3. Make sure that the heat sink for microprocessor n is installed correctly.
  4. (Trained technician only) Replace microprocessor n. (n = microprocessor number)
- **80070201-1104ffff : Sensor [SensorElementName] has transitioned to critical from a less severe state. (PCI 4 Temp)**

This message is for the use case when an implementation has detected a Sensor transitioned to critical from less severe.

May also be shown as 800702011104ffff or 0x800702011104ffff

**Severity**

Error

**Serviceable**

Yes

**Automatically notify support**

No

**Alert Category**

Critical - Temperature

**SNMP Trap ID**

0

**CIM Information**

**Prefix: PLAT ID: 0522**

**User Response**

1. Make sure that the fans are operating, that there are no obstructions to the airflow (front and rear of the server), that the air baffles are in place and correctly installed, and that the server cover is installed and completely closed.
  2. Check the ambient temperature. You must be operating within the specifications (see Features and specifications for more information).
  3. Make sure that the heat sink for microprocessor n is installed correctly.
  4. (Trained technician only) Replace microprocessor n. (n = microprocessor number)
- **80070201-1105ffff : Sensor [SensorElementName] has transitioned to critical from a less severe state. (PCI 5 Temp)**

This message is for the use case when an implementation has detected a Sensor transitioned to critical from less severe.

May also be shown as 800702011105ffff or 0x800702011105ffff

**Severity**

Error

**Serviceable**

Yes

**Automatically notify support**

No

**Alert Category**

Critical - Temperature

**SNMP Trap ID**

0

**CIM Information**

**Prefix:** PLAT ID: 0522

**User Response**

1. Make sure that the fans are operating, that there are no obstructions to the airflow (front and rear of the server), that the air baffles are in place and correctly installed, and that the server cover is installed and completely closed.
  2. Check the ambient temperature. You must be operating within the specifications (see Features and specifications for more information).
  3. Make sure that the heat sink for microprocessor n is installed correctly.
  4. (Trained technician only) Replace microprocessor n. (n = microprocessor number)
- **80070201-1106ffff : Sensor [SensorElementName] has transitioned to critical from a less severe state. (PCI 6 Temp)**

This message is for the use case when an implementation has detected a Sensor transitioned to critical from less severe.

May also be shown as 800702011106ffff or 0x800702011106ffff

**Severity**

Error

**Serviceable**

Yes

**Automatically notify support**

No

**Alert Category**

Critical - Temperature

**SNMP Trap ID**

0

**CIM Information**

**Prefix:** PLAT ID: 0522

**User Response**

1. Make sure that the fans are operating, that there are no obstructions to the airflow (front and rear of the server), that the air baffles are in place and correctly installed, and that the server cover is installed and completely closed.
  2. Check the ambient temperature. You must be operating within the specifications (see Features and specifications for more information).
  3. Make sure that the heat sink for microprocessor n is installed correctly.
  4. (Trained technician only) Replace microprocessor n. (n = microprocessor number)
- **80070201-1107ffff : Sensor [SensorElementName] has transitioned to critical from a less severe state. (PCI 7 Temp)**

This message is for the use case when an implementation has detected a Sensor transitioned to critical from less severe.

May also be shown as 800702011107ffff or 0x800702011107ffff

**Severity**

Error

**Serviceable**

Yes

**Automatically notify support**

No

**Alert Category**

Critical - Temperature

**SNMP Trap ID**

0

**CIM Information**

**Prefix: PLAT ID:** 0522

**User Response**

1. Make sure that the fans are operating, that there are no obstructions to the airflow (front and rear of the server), that the air baffles are in place and correctly installed, and that the server cover is installed and completely closed.
  2. Check the ambient temperature. You must be operating within the specifications (see Features and specifications for more information).
  3. Make sure that the heat sink for microprocessor n is installed correctly.
  4. (Trained technician only) Replace microprocessor n. (n = microprocessor number)
- **80070201-1108ffff : Sensor [SensorElementName] has transitioned to critical from a less severe state. (PCI 8 Temp)**

This message is for the use case when an implementation has detected a Sensor transitioned to critical from less severe.

May also be shown as 800702011108ffff or 0x800702011108ffff

**Severity**

Error

**Serviceable**

Yes

**Automatically notify support**

No

**Alert Category**

Critical - Temperature

**SNMP Trap ID**

0

**CIM Information**

**Prefix: PLAT ID:** 0522

**User Response**

1. Make sure that the fans are operating, that there are no obstructions to the airflow (front and rear of the server), that the air baffles are in place and correctly installed, and that the server cover is installed and completely closed.
2. Check the ambient temperature. You must be operating within the specifications (see Features and specifications for more information).
3. Make sure that the heat sink for microprocessor n is installed correctly.
4. (Trained technician only) Replace microprocessor n. (n = microprocessor number)

- **80070202-0701ffff : Sensor [SensorElementName] has transitioned to critical from a less severe state. (SysBrd Vol Fault)**

This message is for the use case when an implementation has detected a Sensor transitioned to critical from less severe.

May also be shown as 800702020701ffff or 0x800702020701ffff

**Severity**

Error

**Serviceable**

Yes

**Automatically notify support**

No

**Alert Category**

Critical - Voltage

**SNMP Trap ID**

1

**CIM Information**

**Prefix: PLAT ID:** 0522

**User Response**

1. Check the system-event log.
  2. Check for an error LED on the system board.
  3. Replace any failing device.
  4. Check for a server firmware update. Important: Some cluster solutions require specific code levels or coordinated code updates. If the device is part of a cluster solution, verify that the latest level of code is supported for the cluster solution before you update the code.
  5. (Trained technician only) Replace the system board.
- **80070204-0a01ffff : Sensor [SensorElementName] has transitioned to critical from a less severe state. (PS 1 Fan Fault)**

This message is for the use case when an implementation has detected a Sensor transitioned to critical from less severe.

May also be shown as 800702040a01ffff or 0x800702040a01ffff

**Severity**

Error

**Serviceable**

Yes

**Automatically notify support**

No

**Alert Category**

Critical - Fan Failure

**SNMP Trap ID**

11

**CIM Information**

**Prefix: PLAT ID:** 0522

**User Response**

1. Make sure that there are no obstructions, such as bundled cables, to the airflow from the power-supply fan.
  2. Replace power supply n. (n = power supply number)
- **80070204-0a02ffff : Sensor [SensorElementName] has transitioned to critical from a less severe state. (PS 2 Fan Fault)**

This message is for the use case when an implementation has detected a Sensor transitioned to critical from less severe.

May also be shown as 800702040a02ffff or 0x800702040a02ffff

**Severity**

Error

**Serviceable**

Yes

**Automatically notify support**

No

**Alert Category**

Critical - Fan Failure

**SNMP Trap ID**

11

**CIM Information**

Prefix: PLAT ID: 0522

**User Response**

1. Make sure that there are no obstructions, such as bundled cables, to the airflow from the power-supply fan.
  2. Replace power supply n. (n = power supply number)
- **80070208-0a01ffff : Sensor [SensorElementName] has transitioned to critical from a less severe state. (PS 1 Therm Fault)**

This message is for the use case when an implementation has detected a Sensor transitioned to critical from less severe.

May also be shown as 800702080a01ffff or 0x800702080a01ffff

**Severity**

Error

**Serviceable**

Yes

**Automatically notify support**

No

**Alert Category**

Critical - Power

**SNMP Trap ID**

4

**CIM Information**

Prefix: PLAT ID: 0522

**User Response**

1. Make sure that there are no obstructions, such as bundled cables, to the airflow from the power-supply fan.

2. Use the Lenovo Power Configurator utility to ensure current system power consumption is under limitation. For more information and to download the utility, go to <https://www.ibm.com/support/entry/myportal/docdisplay?Indocid=LNVO-PWRCONF>.
3. Replace power supply n. (n = power supply number)

- **80070208-0a02ffff : Sensor [SensorElementName] has transitioned to critical from a less severe state. (PS 2 Therm Fault)**

This message is for the use case when an implementation has detected a Sensor transitioned to critical from less severe.

May also be shown as 800702080a02ffff or 0x800702080a02ffff

**Severity**

Error

**Serviceable**

Yes

**Automatically notify support**

No

**Alert Category**

Critical - Power

**SNMP Trap ID**

4

**CIM Information**

**Prefix:** PLAT ID: 0522

**User Response**

1. Make sure that there are no obstructions, such as bundled cables, to the airflow from the power-supply fan.
  2. Use the Lenovo Power Configurator utility to ensure current system power consumption is under limitation. For more information and to download the utility, go to <https://www.ibm.com/support/entry/myportal/docdisplay?Indocid=LNVO-PWRCONF>.
  3. Replace power supply n. (n = power supply number)
- **8007020c-2585ffff : Sensor [SensorElementName] has transitioned to critical from a less severe state. (nvDIMM Status)**

This message is for the use case when an implementation has detected a Sensor transitioned to critical from less severe.

May also be shown as 8007020c2585ffff or 0x8007020c2585ffff

**Severity**

Error

**Serviceable**

Yes

**Automatically notify support**

No

**Alert Category**

Critical - Other

**SNMP Trap ID**

50

**CIM Information**

**Prefix:** PLAT ID: 0522

**User Response**

None

- **8007020d-2582ffff : Sensor [SensorElementName] has transitioned to critical from a less severe state. (RAID Vol State)**

This message is for the use case when an implementation has detected a Sensor transitioned to critical from less severe.

May also be shown as 8007020d2582ffff or 0x8007020d2582ffff

**Severity**

Error

**Serviceable**

Yes

**Automatically notify support**

No

**Alert Category**

Critical - Other

**SNMP Trap ID**

50

**CIM Information**

**Prefix:** PLAT ID: 0522

**User Response**

1. Run the hard disk drive diagnostic test on drive n.
  2. Reseat the following components: a. Hard disk drive (wait 1 minute or more before reinstalling the drive) b. Cable from the system board to the backplane
  3. Replace the following components one at a time, in the order shown, restarting the server each time: a. Hard disk drive b. Cable from the system board to the backplane c. Hard disk drive backplane (n = hard disk drive number)
- **8007020f-2201ffff : Sensor [SensorElementName] has transitioned to critical from a less severe state. (TXT ACM Module)**

This message is for the use case when an implementation has detected a Sensor transitioned to critical from less severe.

May also be shown as 8007020f2201ffff or 0x8007020f2201ffff

**Severity**

Error

**Serviceable**

Yes

**Automatically notify support**

No

**Alert Category**

Critical - Other

**SNMP Trap ID**

50

**CIM Information**

**Prefix:** PLAT ID: 0522

**User Response**



1. If enabling TXT is not required, disable TXT from the Setup Utility.
2. If enabling TXT is required, verify that the TPM is enabled and activated from the Setup Utility.
3. If the problem remains, contact your service representative.

nvDIMM Flash :

- **8007020f-2582ffff : Sensor [SensorElementName] has transitioned to critical from a less severe state. (I/O Resources)**

This message is for the use case when an implementation has detected a Sensor transitioned to critical from less severe.

May also be shown as 8007020f2582ffff or 0x8007020f2582ffff

**Severity**

Error

**Serviceable**

Yes

**Automatically notify support**

No

**Alert Category**

Critical - Other

**SNMP Trap ID**

50

**CIM Information**

**Prefix:** PLAT ID: 0522

**User Response**

Complete the following step to solve PCI I/O resource errors:

1. Go to F1 Setup
2. System Settings
3. System Settings -> Device and I/O ports "PCI 64 bit Resource"
4. choose "enable"

- **80070214-2201ffff : Sensor [SensorElementName] has transitioned to critical from a less severe state. (TPM Lock)**

This message is for the use case when an implementation has detected a Sensor transitioned to critical from less severe.

May also be shown as 800702142201ffff or 0x800702142201ffff

**Severity**

Error

**Serviceable**

No

**Automatically notify support**

No

**Alert Category**

Critical - Other

**SNMP Trap ID**

50

**CIM Information**

**Prefix:** PLAT ID: 0522

## User Response

1. Update the server firmware (see Recovering the server firmware).
  2. If the problem persists, (trained technician only) replace the system board (see Removing the system board and Installing the system board).
- **80070219-0701ffff : Sensor [SensorElementName] has transitioned to critical from a less severe state. (SysBrd Fault)**

This message is for the use case when an implementation has detected a Sensor transitioned to critical from less severe.

May also be shown as 800702190701ffff or 0x800702190701ffff

## Severity

Error

## Serviceable

Yes

## Automatically notify support

No

## Alert Category

Critical - Other

## SNMP Trap ID

50

## CIM Information

Prefix: PLAT ID: 0522

## User Response

1. Check for an error LED on the system board.
  2. Check the system-event log.
  3. Check for the system firmware version and update to the latest version. Important: Some cluster solutions require specific code levels or coordinated code updates. If the device is part of a cluster solution, verify that the latest level of code is supported for the cluster solution before you update the code.
  4. Unplug and restore AC power cord, then, perform step 1 and 2 again.
  5. If problems still occurred, (trained technician only) replace the system board.
- **8007021b-0301ffff : Sensor [SensorElementName] has transitioned to critical from a less severe state. (CPU 1 QPILinkErr)**

This message is for the use case when an implementation has detected a Sensor transitioned to critical from less severe.

May also be shown as 8007021b0301ffff or 0x8007021b0301ffff

## Severity

Error

## Serviceable

Yes

## Automatically notify support

No

## Alert Category

Critical - Other

## SNMP Trap ID

**CIM Information****Prefix:** PLAT ID: 0522**User Response**

1. Check for a server firmware update.
  2. Make sure that the installed microprocessors are compatible.
  3. Make sure the microprocessor 2 expansion board is installed correctly (see Installing the microprocessor 2 expansion board).
  4. (Trained technician only) Replace microprocessor 2.
  5. (Trained technician only) Replace microprocessor 2 expansion board.
- **8007021b-0302ffff : Sensor [SensorElementName] has transitioned to critical from a less severe state. (CPU 2 QPILinkErr)**

This message is for the use case when an implementation has detected a Sensor transitioned to critical from less severe.

May also be shown as 8007021b0302ffff or 0x8007021b0302ffff

**Severity**

Error

**Serviceable**

Yes

**Automatically notify support**

No

**Alert Category**

Critical - Other

**SNMP Trap ID**

50

**CIM Information****Prefix:** PLAT ID: 0522**User Response**

1. Check for a server firmware update.
  2. Make sure that the installed microprocessors are compatible.
  3. Make sure the microprocessor 2 expansion board is installed correctly (see Installing the microprocessor 2 expansion board).
  4. (Trained technician only) Replace microprocessor 2.
  5. (Trained technician only) Replace microprocessor 2 expansion board.
- **80070228-2e01ffff : Sensor [SensorElementName] has transitioned to critical from a less severe state. (ME Error)**

This message is for the use case when an implementation has detected a Sensor transitioned to critical from less severe.

May also be shown as 800702282e01ffff or 0x800702282e01ffff

**Severity**

Error

**Serviceable**

Yes

**Automatically notify support**

No

**Alert Category**

Critical - Other

**SNMP Trap ID**

50

**CIM Information**

Prefix: PLAT ID: 0522

**User Response**

If the specified sensor is IPMB IO Error, Me Error or ME Flash Error, complete the following steps until the problem is solved:

1. Restart IMM. If the error still appears, proceed step 2.
2. Update the firmware (UEFI and IMM) to the latest level. If the error still appears, proceed step 3.
3. Replace the node.

ME Flash Error :

- **80070301-0301ffff : Sensor [SensorElementName] has transitioned to non-recoverable from a less severe state. (CPU 1 OverTemp)**

This message is for the use case when an implementation has detected a Sensor transitioned to non-recoverable from less severe.

May also be shown as 800703010301ffff or 0x800703010301ffff

**Severity**

Error

**Serviceable**

Yes

**Automatically notify support**

No

**Alert Category**

Critical - Temperature

**SNMP Trap ID**

0

**CIM Information**

Prefix: PLAT ID: 0524

**User Response**

1. Make sure that the fans are operating, that there are no obstructions to the airflow (front and rear of the server), that the air baffle is in place and correctly installed, and that the server cover is installed and completely closed.
  2. Check the ambient temperature. You must be operating within the specifications (see Server Features and specifications for more information).
  3. Make sure that the heat sink for microprocessor n.
  4. (Trained technician only) Replace microprocessor n. (n = microprocessor number)
- **80070301-0302ffff : Sensor [SensorElementName] has transitioned to non-recoverable from a less severe state. (CPU 2 OverTemp)**

This message is for the use case when an implementation has detected a Sensor transitioned to non-recoverable from less severe.

May also be shown as 800703010302ffff or 0x800703010302ffff

**Severity**

Error

**Serviceable**

Yes

**Automatically notify support**

No

**Alert Category**

Critical - Temperature

**SNMP Trap ID**

0

**CIM Information****Prefix: PLAT ID:** 0524**User Response**

1. Make sure that the fans are operating, that there are no obstructions to the airflow (front and rear of the server), that the air baffle is in place and correctly installed, and that the server cover is installed and completely closed.
  2. Check the ambient temperature. You must be operating within the specifications (see Server Features and specifications for more information).
  3. Make sure that the heat sink for microprocessor n.
  4. (Trained technician only) Replace microprocessor n. (n = microprocessor number)
- **80070301-1101ffff : Sensor [SensorElementName] has transitioned to non-recoverable from a less severe state. (PCI 1 Temp)**

This message is for the use case when an implementation has detected a Sensor transitioned to non-recoverable from less severe.

May also be shown as 800703011101ffff or 0x800703011101ffff

**Severity**

Error

**Serviceable**

Yes

**Automatically notify support**

No

**Alert Category**

Critical - Temperature

**SNMP Trap ID**

0

**CIM Information****Prefix: PLAT ID:** 0524**User Response**

1. Make sure that the fans are operating, that there are no obstructions to the airflow (front and rear of the server), that the air baffle is in place and correctly installed, and that the server cover is installed and completely closed.
2. Check the ambient temperature. You must be operating within the specifications (see Server Features and specifications for more information).
3. Make sure that the heat sink for microprocessor n.

4. (Trained technician only) Replace microprocessor n. (n = microprocessor number)

- **80070301-1102ffff : Sensor [SensorElementName] has transitioned to non-recoverable from a less severe state. (PCI 2 Temp)**

This message is for the use case when an implementation has detected a Sensor transitioned to non-recoverable from less severe.

May also be shown as 800703011102ffff or 0x800703011102ffff

**Severity**

Error

**Serviceable**

Yes

**Automatically notify support**

No

**Alert Category**

Critical - Temperature

**SNMP Trap ID**

0

**CIM Information**

**Prefix: PLAT ID:** 0524

**User Response**

1. Make sure that the fans are operating, that there are no obstructions to the airflow (front and rear of the server), that the air baffle is in place and correctly installed, and that the server cover is installed and completely closed.
2. Check the ambient temperature. You must be operating within the specifications (see Server Features and specifications for more information).
3. Make sure that the heat sink for microprocessor n.
4. (Trained technician only) Replace microprocessor n. (n = microprocessor number)

- **80070301-1103ffff : Sensor [SensorElementName] has transitioned to non-recoverable from a less severe state. (PCI 3 Temp)**

This message is for the use case when an implementation has detected a Sensor transitioned to non-recoverable from less severe.

May also be shown as 800703011103ffff or 0x800703011103ffff

**Severity**

Error

**Serviceable**

Yes

**Automatically notify support**

No

**Alert Category**

Critical - Temperature

**SNMP Trap ID**

0

**CIM Information**

**Prefix: PLAT ID:** 0524

**User Response**

1. Make sure that the fans are operating, that there are no obstructions to the airflow (front and rear of the server), that the air baffle is in place and correctly installed, and that the server cover is installed and completely closed.
2. Check the ambient temperature. You must be operating within the specifications (see Server Features and specifications for more information).
3. Make sure that the heat sink for microprocessor n.
4. (Trained technician only) Replace microprocessor n. (n = microprocessor number)

- **80070301-1104ffff : Sensor [SensorElementName] has transitioned to non-recoverable from a less severe state. (PCI 4 Temp)**

This message is for the use case when an implementation has detected a Sensor transitioned to non-recoverable from less severe.

May also be shown as 800703011104ffff or 0x800703011104ffff

**Severity**

Error

**Serviceable**

Yes

**Automatically notify support**

No

**Alert Category**

Critical - Temperature

**SNMP Trap ID**

0

**CIM Information**

**Prefix: PLAT ID: 0524**

**User Response**

1. Make sure that the fans are operating, that there are no obstructions to the airflow (front and rear of the server), that the air baffle is in place and correctly installed, and that the server cover is installed and completely closed.
2. Check the ambient temperature. You must be operating within the specifications (see Server Features and specifications for more information).
3. Make sure that the heat sink for microprocessor n.
4. (Trained technician only) Replace microprocessor n. (n = microprocessor number)

- **80070301-1105ffff : Sensor [SensorElementName] has transitioned to non-recoverable from a less severe state. (PCI 5 Temp)**

This message is for the use case when an implementation has detected a Sensor transitioned to non-recoverable from less severe.

May also be shown as 800703011105ffff or 0x800703011105ffff

**Severity**

Error

**Serviceable**

Yes

**Automatically notify support**

No

**Alert Category**

Critical - Temperature

**SNMP Trap ID**

0

**CIM Information**

**Prefix:** PLAT ID: 0524

**User Response**

1. Make sure that the fans are operating, that there are no obstructions to the airflow (front and rear of the server), that the air baffle is in place and correctly installed, and that the server cover is installed and completely closed.
  2. Check the ambient temperature. You must be operating within the specifications (see Server Features and specifications for more information).
  3. Make sure that the heat sink for microprocessor n.
  4. (Trained technician only) Replace microprocessor n. (n = microprocessor number)
- **80070301-1106ffff : Sensor [SensorElementName] has transitioned to non-recoverable from a less severe state. (PCI 6 Temp)**

This message is for the use case when an implementation has detected a Sensor transitioned to non-recoverable from less severe.

May also be shown as 800703011106ffff or 0x800703011106ffff

**Severity**

Error

**Serviceable**

Yes

**Automatically notify support**

No

**Alert Category**

Critical - Temperature

**SNMP Trap ID**

0

**CIM Information**

**Prefix:** PLAT ID: 0524

**User Response**

1. Make sure that the fans are operating, that there are no obstructions to the airflow (front and rear of the server), that the air baffle is in place and correctly installed, and that the server cover is installed and completely closed.
  2. Check the ambient temperature. You must be operating within the specifications (see Server Features and specifications for more information).
  3. Make sure that the heat sink for microprocessor n.
  4. (Trained technician only) Replace microprocessor n. (n = microprocessor number)
- **80070301-1107ffff : Sensor [SensorElementName] has transitioned to non-recoverable from a less severe state. (PCI 7 Temp)**

This message is for the use case when an implementation has detected a Sensor transitioned to non-recoverable from less severe.

May also be shown as 800703011107ffff or 0x800703011107ffff

**Severity**



Error

**Serviceable**

Yes

**Automatically notify support**

No

**Alert Category**

Critical - Temperature

**SNMP Trap ID**

0

**CIM Information**

**Prefix:** PLAT ID: 0524

**User Response**

1. Make sure that the fans are operating, that there are no obstructions to the airflow (front and rear of the server), that the air baffle is in place and correctly installed, and that the server cover is installed and completely closed.
  2. Check the ambient temperature. You must be operating within the specifications (see Server Features and specifications for more information).
  3. Make sure that the heat sink for microprocessor n.
  4. (Trained technician only) Replace microprocessor n. (n = microprocessor number)
- **80070301-1108ffff : Sensor [SensorElementName] has transitioned to non-recoverable from a less severe state. (PCI 8 Temp)**

This message is for the use case when an implementation has detected a Sensor transitioned to non-recoverable from less severe.

May also be shown as 800703011108ffff or 0x800703011108ffff

**Severity**

Error

**Serviceable**

Yes

**Automatically notify support**

No

**Alert Category**

Critical - Temperature

**SNMP Trap ID**

0

**CIM Information**

**Prefix:** PLAT ID: 0524

**User Response**

1. Make sure that the fans are operating, that there are no obstructions to the airflow (front and rear of the server), that the air baffle is in place and correctly installed, and that the server cover is installed and completely closed.
2. Check the ambient temperature. You must be operating within the specifications (see Server Features and specifications for more information).
3. Make sure that the heat sink for microprocessor n.
4. (Trained technician only) Replace microprocessor n. (n = microprocessor number)

- **80070301-2c01ffff : Sensor [SensorElementName] has transitioned to non-recoverable from a less severe state. (ML2 OverTemp)**

This message is for the use case when an implementation has detected a Sensor transitioned to non-recoverable from less severe.

May also be shown as 800703012c01ffff or 0x800703012c01ffff

**Severity**

Error

**Serviceable**

Yes

**Automatically notify support**

No

**Alert Category**

Critical - Temperature

**SNMP Trap ID**

0

**CIM Information**

**Prefix: PLAT ID:** 0524

**User Response**

1. Make sure that the fans are operating, that there are no obstructions to the airflow (front and rear of the server), that the air baffle is in place and correctly installed, and that the server cover is installed and completely closed.
  2. Check the ambient temperature. You must be operating within the specifications (see Server Features and specifications for more information).
  3. Make sure that the heat sink for microprocessor n.
  4. (Trained technician only) Replace microprocessor n. (n = microprocessor number)
- **8007030d-2582ffff : Sensor [SensorElementName] has transitioned to non-recoverable from a less severe state. (RAID Vol State)**

This message is for the use case when an implementation has detected a Sensor transitioned to non-recoverable from less severe.

May also be shown as 8007030d2582ffff or 0x8007030d2582ffff

**Severity**

Error

**Serviceable**

Yes

**Automatically notify support**

No

**Alert Category**

Critical - Other

**SNMP Trap ID**

50

**CIM Information**

**Prefix: PLAT ID:** 0524

**User Response**

1. Run the hard disk drive diagnostic test on drive n.

2. Reseat the following components: a. Hard disk drive (wait 1 minute or more before reinstalling the drive) b. Cable from the system board to the backplane
  3. Replace the following components one at a time, in the order shown, restarting the server each time: a. Hard disk drive b. Cable from the system board to the backplane c. Hard disk drive backplane (n = hard disk drive number)
- **80070608-0a01ffff : Sensor [SensorElementName] has transitioned to non-recoverable. (PS1 12V OC Fault)**

This message is for the use case when an implementation has detected a Sensor transitioned to non-recoverable.

May also be shown as 800706080a01ffff or 0x800706080a01ffff

**Severity**

Error

**Serviceable**

Yes

**Automatically notify support**

No

**Alert Category**

Critical - Power

**SNMP Trap ID**

4

**CIM Information**

**Prefix:** PLAT ID: 0530

**User Response**

If the specified sensor is PS n 12V OC Fault, complete the following steps until the problem is solved:

1. Use the Lenovo Power Configurator utility to determine current system power consumption. For more information and to download the utility, go to <https://www.ibm.com/support/entry/myportal/docdisplay?Indocid=LNVO-PWRCONF>.
2. Follow actions in "Power Problems and Solving Power Problems".

If the specified sensor is PS n 12V OV Fault, complete the following steps until the problem is solved:

1. Check power supply n LED.
2. Remove the failing power supply.
3. (Trained technician only) Replace the system board. (n = power supply number)

If the specified sensor is PS n 12V UV Fault, complete the following steps until the problem is solved:

1. Check power supply n LED.
2. Remove the failing power supply.
3. Follow actions in "Power Problems and Solving Power Problems".
4. (Trained technician only) Replace the system board. (n = power supply number)

If the specified sensor is PS n 12Vaux Fault, complete the following steps until the problem is solved:

1. Check power supply n LED.
2. Replace power supply n. (n = power supply number)

PS1 12V OV Fault : PS1 12V UV Fault : PS1 12Vaux Fault :

- **80070608-0a02ffff : Sensor [SensorElementName] has transitioned to non-recoverable. (PS2 12V OC Fault)**

This message is for the use case when an implementation has detected a Sensor transitioned to non-recoverable.

May also be shown as 800706080a02ffff or 0x800706080a02ffff

**Severity**

Error

**Serviceable**

Yes

**Automatically notify support**

No

**Alert Category**

Critical - Power

**SNMP Trap ID**

4

**CIM Information**

Prefix: PLAT ID: 0530

**User Response**

If the specified sensor is PS n 12V OC Fault, complete the following steps until the problem is solved:

1. Use the Lenovo Power Configurator utility to determine current system power consumption. For more information and to download the utility, go to <https://www.ibm.com/support/entry/myportal/docdisplay?Indocid=LNVO-PWRCONF>.
2. Follow actions in "Power Problems and Solving Power Problems".

If the specified sensor is PS n 12V OV Fault, complete the following steps until the problem is solved:

1. Check power supply n LED.
2. Remove the failing power supply.
3. (Trained technician only) Replace the system board. (n = power supply number)

If the specified sensor is PS n 12V UV Fault, complete the following steps until the problem is solved:

1. Check power supply n LED.
2. Remove the failing power supply.
3. Follow actions in "Power Problems and Solving Power Problems".
4. (Trained technician only) Replace the system board. (n = power supply number)

If the specified sensor is PS n 12Vaux Fault, complete the following steps until the problem is solved:

1. Check power supply n LED.
2. Replace power supply n. (n = power supply number)

PS2 12V OV Fault : PS2 12V UV Fault : PS2 12Vaux Fault :

- **80070614-2201ffff : Sensor [SensorElementName] has transitioned to non-recoverable. (TPM Phys Pres Set)**

This message is for the use case when an implementation has detected a Sensor transitioned to non-recoverable.

May also be shown as 800706142201ffff or 0x800706142201ffff

**Severity**

Error

**Serviceable**

Yes

**Automatically notify support**

No

**Alert Category**

Critical - Other

**SNMP Trap ID**

50

**CIM Information**

**Prefix: PLAT ID:** 0530

**User Response**

1. Update the server firmware (see Recovering the server firmware).
  2. If the problem persists, (trained technician only) replace the system board (see Removing the system board and Installing the system board).
- **80070625-2583ffff : Sensor [SensorElementName] has transitioned to non-recoverable. (X8 PCI 1 Config)**

This message is for the use case when an implementation has detected a Sensor transitioned to non-recoverable.

May also be shown as 800706252583ffff or 0x800706252583ffff

**Severity**

Error

**Serviceable**

Yes

**Automatically notify support**

No

**Alert Category**

Critical - Other

**SNMP Trap ID**

50

**CIM Information**

**Prefix: PLAT ID:** 0530

**User Response**

None X8 PCI 2 Config : X8 PCI 6 Config : X8 PCI 7 Config :

- **8008010f-2101ffff : Device [LogicalDeviceElementName] has been added. (Phy Presence Jmp)**

This message is for the use case when an implementation has detected a Device was inserted.

May also be shown as 8008010f2101ffff or 0x8008010f2101ffff

**Severity**

Info

**Serviceable**

No

**Automatically notify support**

No

**Alert Category**

System - Other

**SNMP Trap ID**

**CIM Information**

Prefix: PLAT ID: 0536

**User Response**

No action; information only.

- **80080128-2101ffff : Device [LogicalDeviceElementName] has been added. (Low Security Jmp)**

This message is for the use case when an implementation has detected a Device was inserted.

May also be shown as 800801282101ffff or 0x800801282101ffff

**Severity**

Info

**Serviceable**

No

**Automatically notify support**

No

**Alert Category**

System - Other

**SNMP Trap ID****CIM Information**

Prefix: PLAT ID: 0536

**User Response**

No action; information only.

- **800b0008-1301ffff : Redundancy [RedundancySetElementName] has been restored. (Power Unit)**

This message is for the use case when an implementation has detected Redundancy was Restored.

May also be shown as 800b00081301ffff or 0x800b00081301ffff

**Severity**

Info

**Serviceable**

No

**Automatically notify support**

No

**Alert Category**

Warning - Redundant Power Supply

**SNMP Trap ID**

10

**CIM Information**

Prefix: PLAT ID: 0561

**User Response**

No action; information only.

- **800b0108-1301ffff : Redundancy Lost for [RedundancySetElementName] has asserted. (Power Unit)**

This message is for the use case when Redundancy Lost has asserted.

May also be shown as 800b01081301ffff or 0x800b01081301ffff

**Severity**

Error

**Serviceable**

Yes

**Automatically notify support**

No

**Alert Category**

Critical - Redundant Power Supply

**SNMP Trap ID**

9

**CIM Information**

**Prefix: PLAT ID:** 0802

**User Response**

1. Check the LEDs for both power supplies.
  2. Follow the actions in Power-supply LEDs.
- **800b010a-1e81ffff : Redundancy Lost for [RedundancySetElementName] has asserted. (Fan Zone 1)**

This message is for the use case when Redundancy Lost has asserted.

May also be shown as 800b010a1e81ffff or 0x800b010a1e81ffff

**Severity**

Error

**Serviceable**

Yes

**Automatically notify support**

No

**Alert Category**

Critical - Fan Failure

**SNMP Trap ID**

11

**CIM Information**

**Prefix: PLAT ID:** 0802

**User Response**

1. Make sure that the connectors on fan n are not damaged.
  2. Make sure that the fan n connectors on the system board are not damaged.
  3. Make sure that the fans are correctly installed.
  4. Reseat the fans.
  5. Replace the fans. (n = fan number)
- **800b010a-1e82ffff : Redundancy Lost for [RedundancySetElementName] has asserted. (Fan Zone 2)**

This message is for the use case when Redundancy Lost has asserted.

May also be shown as 800b010a1e82ffff or 0x800b010a1e82ffff

**Severity**

Error

**Serviceable**

Yes

**Automatically notify support**

No

**Alert Category**

Critical - Fan Failure

**SNMP Trap ID**

11

**CIM Information**

Prefix: PLAT ID: 0802

**User Response**

1. Make sure that the connectors on fan n are not damaged.
  2. Make sure that the fan n connectors on the system board are not damaged.
  3. Make sure that the fans are correctly installed.
  4. Reseat the fans.
  5. Replace the fans. (n = fan number)
- **800b010a-1e83ffff : Redundancy Lost for [RedundancySetElementName] has asserted. (Fan Zone 3)**

This message is for the use case when Redundancy Lost has asserted.

May also be shown as 800b010a1e83ffff or 0x800b010a1e83ffff

**Severity**

Error

**Serviceable**

Yes

**Automatically notify support**

No

**Alert Category**

Critical - Fan Failure

**SNMP Trap ID**

11

**CIM Information**

Prefix: PLAT ID: 0802

**User Response**

1. Make sure that the connectors on fan n are not damaged.
  2. Make sure that the fan n connectors on the system board are not damaged.
  3. Make sure that the fans are correctly installed.
  4. Reseat the fans.
  5. Replace the fans. (n = fan number)
- **800b010a-1e84ffff : Redundancy Lost for [RedundancySetElementName] has asserted. (Fan Zone 4)**

This message is for the use case when Redundancy Lost has asserted.

May also be shown as 800b010a1e84ffff or 0x800b010a1e84ffff

**Severity**

Error



**Serviceable**

Yes

**Automatically notify support**

No

**Alert Category**

Critical - Fan Failure

**SNMP Trap ID**

11

**CIM Information**

Prefix: PLAT ID: 0802

**User Response**

1. Make sure that the connectors on fan n are not damaged.
  2. Make sure that the fan n connectors on the system board are not damaged.
  3. Make sure that the fans are correctly installed.
  4. Reseat the fans.
  5. Replace the fans. (n = fan number)
- **800b010c-2581ffff : Redundancy Lost for [RedundancySetElementName] has asserted. (Backup Memory)**

This message is for the use case when Redundancy Lost has asserted.

May also be shown as 800b010c2581ffff or 0x800b010c2581ffff

**Severity**

Error

**Serviceable**

Yes

**Automatically notify support**

No

**Alert Category**

Critical - Memory

**SNMP Trap ID**

41

**CIM Information**

Prefix: PLAT ID: 0802

**User Response**

1. If you have added or removed DIMMs to the system, and no additional errors were detected, then please ignore this message.
  2. Check system event log for uncorrected DIMM failures.
  3. Replace those DIMMs.
  4. Re-enable mirroring in the Setup utility.
- **800b0309-1301ffff : Non-redundant:Sufficient Resources from Redundancy Degraded or Fully Redundant for [RedundancySetElementName] has asserted. (Power Resource)**

This message is for the use case when a Redundancy Set has transitioned from Redundancy Degraded or Fully Redundant to Non-redundant:Sufficient.

May also be shown as 800b03091301ffff or 0x800b03091301ffff

**Severity**

Warning

**Serviceable**

Yes

**Automatically notify support**

No

**Alert Category**

Warning - Redundant Power Supply

**SNMP Trap ID**

10

**CIM Information**

**Prefix:** PLAT ID: 0806

**User Response**

1. Non-redundant sufficient: Power load will be handled by remaining power supply, though the system may throttle to avoid a power supply over-current condition.
  2. Please check and reseat the lost power cord or power supply.
  3. Please replace the failed power supply.
- **800b030c-2581ffff : Non-redundant:Sufficient Resources from Redundancy Degraded or Fully Redundant for [RedundancySetElementName] has asserted. (Backup Memory)**

This message is for the use case when a Redundancy Set has transitioned from Redundancy Degraded or Fully Redundant to Non-redundant:Sufficient.

May also be shown as 800b030c2581ffff or 0x800b030c2581ffff

**Severity**

Warning

**Serviceable**

Yes

**Automatically notify support**

No

**Alert Category**

Warning - Memory

**SNMP Trap ID**

43

**CIM Information**

**Prefix:** PLAT ID: 0806

**User Response**

1. Check the system-event log for DIMM failure events (uncorrectable or PFA) and correct the failures.
  2. Re-enable mirroring in the Setup utility.
- **800b0509-1301ffff : Non-redundant:Insufficient Resources for [RedundancySetElementName] has asserted. (Power Resource)**

This message is for the use case when a Redundancy Set has transitioned to Non-redundant:Insufficient Resources.

May also be shown as 800b05091301ffff or 0x800b05091301ffff

**Severity**

Error

**Serviceable**

Yes

**Automatically notify support**

No

**Alert Category**

Critical - Redundant Power Supply

**SNMP Trap ID**

9

**CIM Information**

**Prefix:** PLAT ID: 0810

**User Response**

1. Power load may be handled by remaining power supply. The system will attempt to throttle to avoid a power supply over-current condition. But a system shutdown may happen anyway if the power load is too great.
  2. Reduce the total power consumption by removing newly added or unused options like drives or adaptors.
  3. Use the Lenovo Power Configurator utility to determine current system power consumption. For more information and to download the utility, go to <https://www.ibm.com/support/entry/myportal/docdisplay?Indocid=LNVO-PWRCONF>.
  4. Replace the power supply with higher rated power if Oversubscription\_Fault seen in power supply.
  5. Please reseal power cords and power supplies.
- **800b050a-1e81ffff : Non-redundant:Insufficient Resources for [RedundancySetElementName] has asserted. (Fan Zone 1)**

This message is for the use case when a Redundancy Set has transitioned to Non-redundant:Insufficient Resources.

May also be shown as 800b050a1e81ffff or 0x800b050a1e81ffff

**Severity**

Error

**Serviceable**

Yes

**Automatically notify support**

No

**Alert Category**

Critical - Fan Failure

**SNMP Trap ID**

11

**CIM Information**

**Prefix:** PLAT ID: 0810

**User Response**

1. Make sure that the connectors on fan n are not damaged.
2. Make sure that the fan n connectors on the system board are not damaged.
3. Make sure that the fans are correctly installed.

4. Reseat the fans.
  5. Replace the fans. (n = fan number)
- **800b050a-1e82ffff : Non-redundant:Insufficient Resources for [RedundancySetElementName] has asserted. (Fan Zone 2)**

This message is for the use case when a Redundancy Set has transitioned to Non-redundant:Insufficient Resources.

May also be shown as 800b050a1e82ffff or 0x800b050a1e82ffff

**Severity**

Error

**Serviceable**

Yes

**Automatically notify support**

No

**Alert Category**

Critical - Fan Failure

**SNMP Trap ID**

11

**CIM Information**

Prefix: PLAT ID: 0810

**User Response**

1. Make sure that the connectors on fan n are not damaged.
  2. Make sure that the fan n connectors on the system board are not damaged.
  3. Make sure that the fans are correctly installed.
  4. Reseat the fans.
  5. Replace the fans. (n = fan number)
- **800b050a-1e83ffff : Non-redundant:Insufficient Resources for [RedundancySetElementName] has asserted. (Fan Zone 3)**

This message is for the use case when a Redundancy Set has transitioned to Non-redundant:Insufficient Resources.

May also be shown as 800b050a1e83ffff or 0x800b050a1e83ffff

**Severity**

Error

**Serviceable**

Yes

**Automatically notify support**

No

**Alert Category**

Critical - Fan Failure

**SNMP Trap ID**

11

**CIM Information**

Prefix: PLAT ID: 0810

**User Response**

1. Make sure that the connectors on fan n are not damaged.
2. Make sure that the fan n connectors on the system board are not damaged.
3. Make sure that the fans are correctly installed.
4. Reseat the fans.
5. Replace the fans. (n = fan number)

- **800b050a-1e84ffff : Non-redundant:Insufficient Resources for [RedundancySetElementName] has asserted. (Fan Zone 4)**

This message is for the use case when a Redundancy Set has transitioned to Non-redundant:Insufficient Resources.

May also be shown as 800b050a1e84ffff or 0x800b050a1e84ffff

**Severity**

Error

**Serviceable**

Yes

**Automatically notify support**

No

**Alert Category**

Critical - Fan Failure

**SNMP Trap ID**

11

**CIM Information**

**Prefix:** PLAT ID: 0810

**User Response**

1. Make sure that the connectors on fan n are not damaged.
2. Make sure that the fan n connectors on the system board are not damaged.
3. Make sure that the fans are correctly installed.
4. Reseat the fans.
5. Replace the fans. (n = fan number)

- **800b050c-2581ffff : Non-redundant:Insufficient Resources for [RedundancySetElementName] has asserted. (Backup Memory)**

This message is for the use case when a Redundancy Set has transitioned to Non-redundant:Insufficient Resources.

May also be shown as 800b050c2581ffff or 0x800b050c2581ffff

**Severity**

Error

**Serviceable**

Yes

**Automatically notify support**

No

**Alert Category**

Critical - Memory

**SNMP Trap ID**

41

**CIM Information**

Prefix: PLAT ID: 0810

**User Response**

1. Check the system-event log for DIMM failure events (uncorrectable or PFA) and correct the failures.
  2. Re-enable mirroring in the Setup utility.
- **806f0007-0301ffff : [ProcessorElementName] has Failed with IERR. (CPU 1)**

This message is for the use case when an implementation has detected a Processor Failed - IERR Condition.

May also be shown as 806f00070301ffff or 0x806f00070301ffff

**Severity**

Error

**Serviceable**

Yes

**Automatically notify support**

No

**Alert Category**

Critical - CPU

**SNMP Trap ID**

40

**CIM Information**

Prefix: PLAT ID: 0042

**User Response**

1. Make sure that the latest level of firmware and device drivers are installed for all adapters and standard devices, such as Ethernet, SCSI, and SAS. Important: Some cluster solutions require specific code levels or coordinated code updates. If the device is part of a cluster solution, verify that the latest level of code is supported for the cluster solution before you update the code.
  2. Update the firmware (UEFI and IMM) to the latest level (Updating the firmware).
  3. Run the DSA program.
  4. Reseat the adapter.
  5. Replace the adapter.
  6. (Trained technician only) Replace microprocessor n.
  7. (Trained technician only) Replace the system board. (n = microprocessor number)
- **806f0007-0302ffff : [ProcessorElementName] has Failed with IERR. (CPU 2)**

This message is for the use case when an implementation has detected a Processor Failed - IERR Condition.

May also be shown as 806f00070302ffff or 0x806f00070302ffff

**Severity**

Error

**Serviceable**

Yes

**Automatically notify support**

No

**Alert Category**

Critical - CPU

**SNMP Trap ID**

40

**CIM Information**

**Prefix:** PLAT ID: 0042

**User Response**

1. Make sure that the latest level of firmware and device drivers are installed for all adapters and standard devices, such as Ethernet, SCSI, and SAS. Important: Some cluster solutions require specific code levels or coordinated code updates. If the device is part of a cluster solution, verify that the latest level of code is supported for the cluster solution before you update the code.
  2. Update the firmware (UEFI and IMM) to the latest level (Updating the firmware).
  3. Run the DSA program.
  4. Reseat the adapter.
  5. Replace the adapter.
  6. (Trained technician only) Replace microprocessor n.
  7. (Trained technician only) Replace the system board. (n = microprocessor number)
- **806f0008-0a01ffff : [PowerSupplyElementName] has been added to container [PhysicalPackageElementName]. (Power Supply 1)**

This message is for the use case when an implementation has detected a Power Supply has been added.

May also be shown as 806f00080a01ffff or 0x806f00080a01ffff

**Severity**

Info

**Serviceable**

No

**Automatically notify support**

No

**Alert Category**

System - Other

**SNMP Trap ID****CIM Information**

**Prefix:** PLAT ID: 0084

**User Response**

No action; information only.

- **806f0008-0a02ffff : [PowerSupplyElementName] has been added to container [PhysicalPackageElementName]. (Power Supply 2)**

This message is for the use case when an implementation has detected a Power Supply has been added.

May also be shown as 806f00080a02ffff or 0x806f00080a02ffff

**Severity**

Info

**Serviceable**

No

**Automatically notify support**

No

**Alert Category**

System - Other

**SNMP Trap ID****CIM Information**

Prefix: PLAT ID: 0084

**User Response**

No action; information only.

- **806f0009-1301ffff : [PowerSupplyElementName] has been turned off. (Host Power)**

This message is for the use case when an implementation has detected a Power Unit that has been Disabled.

May also be shown as 806f00091301ffff or 0x806f00091301ffff

**Severity**

Info

**Serviceable**

No

**Automatically notify support**

No

**Alert Category**

System - Power Off

**SNMP Trap ID**

23

**CIM Information**

Prefix: PLAT ID: 0106

**User Response**

No action; information only.

- **806f000d-0400ffff : The Drive [StorageVolumeElementName] has been added. (Drive 0)**

This message is for the use case when an implementation has detected a Drive has been Added.

May also be shown as 806f000d0400ffff or 0x806f000d0400ffff

**Severity**

Info

**Serviceable**

No

**Automatically notify support**

No

**Alert Category**

System - Other

**SNMP Trap ID**

22

**CIM Information**

Prefix: PLAT ID: 0162



**User Response**

No action; information only.

- **806f000d-0401ffff : The Drive [StorageVolumeElementName] has been added. (Drive 1)**

This message is for the use case when an implementation has detected a Drive has been Added.

May also be shown as 806f000d0401ffff or 0x806f000d0401ffff

**Severity**

Info

**Serviceable**

No

**Automatically notify support**

No

**Alert Category**

System - Other

**SNMP Trap ID**

22

**CIM Information**

**Prefix: PLAT ID:** 0162

**User Response**

No action; information only.

- **806f000d-0402ffff : The Drive [StorageVolumeElementName] has been added. (Drive 2)**

This message is for the use case when an implementation has detected a Drive has been Added.

May also be shown as 806f000d0402ffff or 0x806f000d0402ffff

**Severity**

Info

**Serviceable**

No

**Automatically notify support**

No

**Alert Category**

System - Other

**SNMP Trap ID**

22

**CIM Information**

**Prefix: PLAT ID:** 0162

**User Response**

No action; information only.

- **806f000d-0403ffff : The Drive [StorageVolumeElementName] has been added. (Drive 3)**

This message is for the use case when an implementation has detected a Drive has been Added.

May also be shown as 806f000d0403ffff or 0x806f000d0403ffff

**Severity**

Info

**Serviceable**

No

**Automatically notify support**

No

**Alert Category**

System - Other

**SNMP Trap ID**

22

**CIM Information**

Prefix: PLAT ID: 0162

**User Response**

No action; information only.

- **806f000d-0404ffff : The Drive [StorageVolumeElementName] has been added. (Drive 4)**

This message is for the use case when an implementation has detected a Drive has been Added.

May also be shown as 806f000d0404ffff or 0x806f000d0404ffff

**Severity**

Info

**Serviceable**

No

**Automatically notify support**

No

**Alert Category**

System - Other

**SNMP Trap ID**

22

**CIM Information**

Prefix: PLAT ID: 0162

**User Response**

No action; information only.

- **806f000d-0405ffff : The Drive [StorageVolumeElementName] has been added. (Drive 5)**

This message is for the use case when an implementation has detected a Drive has been Added.

May also be shown as 806f000d0405ffff or 0x806f000d0405ffff

**Severity**

Info

**Serviceable**

No

**Automatically notify support**

No

**Alert Category**

System - Other

**SNMP Trap ID**

22

**CIM Information**

Prefix: PLAT ID: 0162

**User Response**

No action; information only.

- **806f000d-0406ffff : The Drive [StorageVolumeElementName] has been added. (Drive 6)**

This message is for the use case when an implementation has detected a Drive has been Added.

May also be shown as 806f000d0406ffff or 0x806f000d0406ffff

**Severity**

Info

**Serviceable**

No

**Automatically notify support**

No

**Alert Category**

System - Other

**SNMP Trap ID**

22

**CIM Information**

**Prefix: PLAT ID:** 0162

**User Response**

No action; information only.

- **806f000d-0407ffff : The Drive [StorageVolumeElementName] has been added. (Drive 7)**

This message is for the use case when an implementation has detected a Drive has been Added.

May also be shown as 806f000d0407ffff or 0x806f000d0407ffff

**Severity**

Info

**Serviceable**

No

**Automatically notify support**

No

**Alert Category**

System - Other

**SNMP Trap ID**

22

**CIM Information**

**Prefix: PLAT ID:** 0162

**User Response**

No action; information only.

- **806f000d-0408ffff : The Drive [StorageVolumeElementName] has been added. (Drive 8)**

This message is for the use case when an implementation has detected a Drive has been Added.

May also be shown as 806f000d0408ffff or 0x806f000d0408ffff

**Severity**

Info

**Serviceable**

No

**Automatically notify support**

No

**Alert Category**

System - Other

**SNMP Trap ID**

22

**CIM Information**

Prefix: PLAT ID: 0162

**User Response**

No action; information only.

- **806f000d-0409ffff : The Drive [StorageVolumeElementName] has been added. (Drive 9)**

This message is for the use case when an implementation has detected a Drive has been Added.

May also be shown as 806f000d0409ffff or 0x806f000d0409ffff

**Severity**

Info

**Serviceable**

No

**Automatically notify support**

No

**Alert Category**

System - Other

**SNMP Trap ID**

22

**CIM Information**

Prefix: PLAT ID: 0162

**User Response**

No action; information only.

- **806f000d-040affff : The Drive [StorageVolumeElementName] has been added. (Drive 10)**

This message is for the use case when an implementation has detected a Drive has been Added.

May also be shown as 806f000d040affff or 0x806f000d040affff

**Severity**

Info

**Serviceable**

No

**Automatically notify support**

No

**Alert Category**

System - Other

**SNMP Trap ID**

22

**CIM Information**

Prefix: PLAT ID: 0162

**User Response**

No action; information only.

- **806f000d-040bffff : The Drive [StorageVolumeElementName] has been added. (Drive 11)**

This message is for the use case when an implementation has detected a Drive has been Added.

May also be shown as 806f000d040bffff or 0x806f000d040bffff

**Severity**

Info

**Serviceable**

No

**Automatically notify support**

No

**Alert Category**

System - Other

**SNMP Trap ID**

22

**CIM Information**

**Prefix: PLAT ID:** 0162

**User Response**

No action; information only.

- **806f000d-040cffff : The Drive [StorageVolumeElementName] has been added. (Drive 12)**

This message is for the use case when an implementation has detected a Drive has been Added.

May also be shown as 806f000d040cffff or 0x806f000d040cffff

**Severity**

Info

**Serviceable**

No

**Automatically notify support**

No

**Alert Category**

System - Other

**SNMP Trap ID**

22

**CIM Information**

**Prefix: PLAT ID:** 0162

**User Response**

No action; information only.

- **806f000d-040dffff : The Drive [StorageVolumeElementName] has been added. (Drive 13)**

This message is for the use case when an implementation has detected a Drive has been Added.

May also be shown as 806f000d040dffff or 0x806f000d040dffff

**Severity**

Info

**Serviceable**

No

**Automatically notify support**

No

**Alert Category**

System - Other

**SNMP Trap ID**

22

**CIM Information**

Prefix: PLAT ID: 0162

**User Response**

No action; information only.

- **806f000d-040effff : The Drive [StorageVolumeElementName] has been added. (Drive 14)**

This message is for the use case when an implementation has detected a Drive has been Added.

May also be shown as 806f000d040effff or 0x806f000d040effff

**Severity**

Info

**Serviceable**

No

**Automatically notify support**

No

**Alert Category**

System - Other

**SNMP Trap ID**

22

**CIM Information**

Prefix: PLAT ID: 0162

**User Response**

No action; information only.

- **806f000d-040fffff : The Drive [StorageVolumeElementName] has been added. (Drive 15)**

This message is for the use case when an implementation has detected a Drive has been Added.

May also be shown as 806f000d040fffff or 0x806f000d040fffff

**Severity**

Info

**Serviceable**

No

**Automatically notify support**

No

**Alert Category**

System - Other

**SNMP Trap ID**

22

**CIM Information**

Prefix: PLAT ID: 0162

**User Response**

No action; information only.

- **806f000d-0410ffff : The Drive [StorageVolumeElementName] has been added. (Drive 16)**

This message is for the use case when an implementation has detected a Drive has been Added.

May also be shown as 806f000d0410ffff or 0x806f000d0410ffff

**Severity**

Info

**Serviceable**

No

**Automatically notify support**

No

**Alert Category**

System - Other

**SNMP Trap ID**

22

**CIM Information**

**Prefix: PLAT ID:** 0162

**User Response**

No action; information only.

- **806f000d-0411ffff : The Drive [StorageVolumeElementName] has been added. (Drive 17)**

This message is for the use case when an implementation has detected a Drive has been Added.

May also be shown as 806f000d0411ffff or 0x806f000d0411ffff

**Severity**

Info

**Serviceable**

No

**Automatically notify support**

No

**Alert Category**

System - Other

**SNMP Trap ID**

22

**CIM Information**

**Prefix: PLAT ID:** 0162

**User Response**

No action; information only.

- **806f000d-0412ffff : The Drive [StorageVolumeElementName] has been added. (Drive 18)**

This message is for the use case when an implementation has detected a Drive has been Added.

May also be shown as 806f000d0412ffff or 0x806f000d0412ffff

**Severity**

Info

**Serviceable**

No

**Automatically notify support**

No

**Alert Category**

System - Other

**SNMP Trap ID**

22

**CIM Information**

Prefix: PLAT ID: 0162

**User Response**

No action; information only.

- **806f000d-0413ffff : The Drive [StorageVolumeElementName] has been added. (Drive 19)**

This message is for the use case when an implementation has detected a Drive has been Added.

May also be shown as 806f000d0413ffff or 0x806f000d0413ffff

**Severity**

Info

**Serviceable**

No

**Automatically notify support**

No

**Alert Category**

System - Other

**SNMP Trap ID**

22

**CIM Information**

Prefix: PLAT ID: 0162

**User Response**

No action; information only.

- **806f000d-0414ffff : The Drive [StorageVolumeElementName] has been added. (Drive 20)**

This message is for the use case when an implementation has detected a Drive has been Added.

May also be shown as 806f000d0414ffff or 0x806f000d0414ffff

**Severity**

Info

**Serviceable**

No

**Automatically notify support**

No

**Alert Category**

System - Other

**SNMP Trap ID**

22

**CIM Information**

Prefix: PLAT ID: 0162

**User Response**

No action; information only.

- **806f000d-0415ffff : The Drive [StorageVolumeElementName] has been added. (Drive 21)**

This message is for the use case when an implementation has detected a Drive has been Added.

May also be shown as 806f000d0415ffff or 0x806f000d0415ffff



**Severity**

Info

**Serviceable**

No

**Automatically notify support**

No

**Alert Category**

System - Other

**SNMP Trap ID**

22

**CIM Information****Prefix: PLAT ID:** 0162**User Response**

No action; information only.

- **806f000d-0416ffff : The Drive [StorageVolumeElementName] has been added. (Drive 22)**

This message is for the use case when an implementation has detected a Drive has been Added.

May also be shown as 806f000d0416ffff or 0x806f000d0416ffff

**Severity**

Info

**Serviceable**

No

**Automatically notify support**

No

**Alert Category**

System - Other

**SNMP Trap ID**

22

**CIM Information****Prefix: PLAT ID:** 0162**User Response**

No action; information only.

- **806f000d-0417ffff : The Drive [StorageVolumeElementName] has been added. (Drive 23)**

This message is for the use case when an implementation has detected a Drive has been Added.

May also be shown as 806f000d0417ffff or 0x806f000d0417ffff

**Severity**

Info

**Serviceable**

No

**Automatically notify support**

No

**Alert Category**

System - Other

**SNMP Trap ID**

22

**CIM Information**

Prefix: PLAT ID: 0162

**User Response**

No action; information only.

- **806f000d-0418ffff : The Drive [StorageVolumeElementName] has been added. (Drive 24)**

This message is for the use case when an implementation has detected a Drive has been Added.

May also be shown as 806f000d0418ffff or 0x806f000d0418ffff

**Severity**

Info

**Serviceable**

No

**Automatically notify support**

No

**Alert Category**

System - Other

**SNMP Trap ID**

22

**CIM Information**

Prefix: PLAT ID: 0162

**User Response**

No action; information only.

- **806f000d-0419ffff : The Drive [StorageVolumeElementName] has been added. (Drive 25)**

This message is for the use case when an implementation has detected a Drive has been Added.

May also be shown as 806f000d0419ffff or 0x806f000d0419ffff

**Severity**

Info

**Serviceable**

No

**Automatically notify support**

No

**Alert Category**

System - Other

**SNMP Trap ID**

22

**CIM Information**

Prefix: PLAT ID: 0162

**User Response**

No action; information only.

- **806f000d-041affff : The Drive [StorageVolumeElementName] has been added. (Drive 26)**

This message is for the use case when an implementation has detected a Drive has been Added.

May also be shown as 806f000d041affff or 0x806f000d041affff

**Severity**

Info

**Serviceable**

No

**Automatically notify support**

No

**Alert Category**

System - Other

**SNMP Trap ID**

22

**CIM Information**

**Prefix:** PLAT ID: 0162

**User Response**

No action; information only.

- **806f000d-041bffff : The Drive [StorageVolumeElementName] has been added. (Drive 27)**

This message is for the use case when an implementation has detected a Drive has been Added.

May also be shown as 806f000d041bffff or 0x806f000d041bffff

**Severity**

Info

**Serviceable**

No

**Automatically notify support**

No

**Alert Category**

System - Other

**SNMP Trap ID**

22

**CIM Information**

**Prefix:** PLAT ID: 0162

**User Response**

No action; information only.

- **806f000d-041cffff : The Drive [StorageVolumeElementName] has been added. (Drive 28)**

This message is for the use case when an implementation has detected a Drive has been Added.

May also be shown as 806f000d041cffff or 0x806f000d041cffff

**Severity**

Info

**Serviceable**

No

**Automatically notify support**

No

**Alert Category**

System - Other

**SNMP Trap ID**

22

**CIM Information**

**Prefix:** PLAT ID: 0162

**User Response**

No action; information only.

- **806f000d-041dffff : The Drive [StorageVolumeElementName] has been added. (Drive 29)**

This message is for the use case when an implementation has detected a Drive has been Added.

May also be shown as 806f000d041dffff or 0x806f000d041dffff

**Severity**

Info

**Serviceable**

No

**Automatically notify support**

No

**Alert Category**

System - Other

**SNMP Trap ID**

22

**CIM Information**

Prefix: PLAT ID: 0162

**User Response**

No action; information only.

- **806f000d-041effff : The Drive [StorageVolumeElementName] has been added. (Drive 30)**

This message is for the use case when an implementation has detected a Drive has been Added.

May also be shown as 806f000d041effff or 0x806f000d041effff

**Severity**

Info

**Serviceable**

No

**Automatically notify support**

No

**Alert Category**

System - Other

**SNMP Trap ID**

22

**CIM Information**

Prefix: PLAT ID: 0162

**User Response**

No action; information only.

- **806f000d-041fffff : The Drive [StorageVolumeElementName] has been added. (Drive 31)**

This message is for the use case when an implementation has detected a Drive has been Added.

May also be shown as 806f000d041fffff or 0x806f000d041fffff

**Severity**

Info

**Serviceable**

No

**Automatically notify support**

No

**Alert Category**

System - Other

**SNMP Trap ID**

22

**CIM Information**

**Prefix:** PLAT ID: 0162

**User Response**

No action; information only.

- **806f000d-0420ffff : The Drive [StorageVolumeElementName] has been added. (Ext Drive)**

This message is for the use case when an implementation has detected a Drive has been Added.

May also be shown as 806f000d0420ffff or 0x806f000d0420ffff

**Severity**

Info

**Serviceable**

No

**Automatically notify support**

No

**Alert Category**

System - Other

**SNMP Trap ID**

22

**CIM Information**

**Prefix:** PLAT ID: 0162

**User Response**

No action; information only.

- **806f000f-220101ff : The System [ComputerSystemElementName] has detected no memory in the system. (ABR Status)**

This message is for the use case when an implementation has detected that memory was detected in the system.

May also be shown as 806f000f220101ff or 0x806f000f220101ff

**Severity**

Error

**Serviceable**

Yes

**Automatically notify support**

No

**Alert Category**

Critical - Memory

**SNMP Trap ID**

41

**CIM Information**

**Prefix:** PLAT ID: 0794

## User Response

1. Make sure that one or more DIMMs are installed in the server, and resolve any other currently existing memory errors.
2. If no memory fault is recorded in the logs and no DIMM connector error LEDs are lit, verify that all DIMM connectors are enabled using the Setup utility or the ToolsCenter Suite CLI.
3. Re-Install all DIMMs verifying the correct population sequence, according to the service information for this product.
4. Replace DIMMs.
5. Recover the server firmware from the backup page: a. Restart the server. b. At the prompt, press F3 to recover the firmware. c. Update the server firmware on the primary page. Important: Some cluster solutions require specific code levels or coordinated code updates. If the device is part of a cluster solution, verify that the latest level of code is supported for the cluster solution before you update the code.
6. If the problem remains, (trained technician only) replace the system board.

Firmware Error : Sys Boot Status : X8 PCI 1 Firm : X8 PCI 2 Firm : X8 PCI 6 Firm : X8 PCI 7 Firm :

- **806f000f-220102ff : Subsystem [MemoryElementName] has insufficient memory for operation. (ABR Status)**

This message is for the use case when an implementation has detected that the usable Memory is insufficient for operation.

May also be shown as 806f000f220102ff or 0x806f000f220102ff

### Severity

Error

### Serviceable

Yes

### Automatically notify support

No

### Alert Category

Critical - Memory

### SNMP Trap ID

41

### CIM Information

Prefix: PLAT ID: 0132

## User Response

1. Make sure that one or more DIMMs are installed in the server, and resolve any other currently existing memory errors.
2. If no memory fault is recorded in the logs and no DIMM connector error LEDs are lit, verify that all DIMM connectors are enabled using the Setup utility or the ToolsCenter Suite CLI.
3. Re-Install all DIMMs verifying the correct population sequence, according to the service information for this product.
4. Replace DIMMs.
5. Recover the server firmware from the backup page: a. Restart the server. b. At the prompt, press F3 to recover the firmware. c. Update the server firmware on the primary page. Important: Some cluster solutions require specific code levels or coordinated code updates. If the device is part of a cluster solution, verify that the latest level of code is supported for the cluster solution before you update the code.
6. If the problem remains, (trained technician only) replace the system board.

Firmware Error : Sys Boot Status : X8 PCI 1 Firm : X8 PCI 2 Firm : X8 PCI 6 Firm : X8 PCI 7 Firm :

- **806f000f-220103ff : The System [ComputerSystemElementName] encountered firmware error - unrecoverable boot device failure. (ABR Status)**

This message is for the use case when an implementation has detected that System Firmware Error Unrecoverable boot device failure has occurred.

May also be shown as 806f000f220103ff or 0x806f000f220103ff

**Severity**

Error

**Serviceable**

Yes

**Automatically notify support**

No

**Alert Category**

Critical - Hard Disk drive

**SNMP Trap ID**

5

**CIM Information**

**Prefix:** PLAT ID: 0770

**User Response**

This is a UEFI detected event. The UEFI(POST) error code for this event can be found in the logged IMM message text. Please refer to the UEFI(POST) error code in the "UEFI(POST) error code" section of the Information Center for the appropriate user response. Firmware Error : Sys Boot Status : X8 PCI 1 Firm : X8 PCI 2 Firm : X8 PCI 6 Firm : X8 PCI 7 Firm :

- **806f000f-220104ff : The System [ComputerSystemElementName]has encountered a motherboard failure. (ABR Status)**

This message is for the use case when an implementation has detected that a fatal motherboard failure in the system.

May also be shown as 806f000f220104ff or 0x806f000f220104ff

**Severity**

Error

**Serviceable**

Yes

**Automatically notify support**

No

**Alert Category**

Critical - Other

**SNMP Trap ID**

50

**CIM Information**

**Prefix:** PLAT ID: 0795

**User Response**

This is a UEFI detected event. The UEFI(POST) error code for this event can be found in the logged IMM message text. Please refer to the UEFI(POST) error code in the "UEFI(POST) error code" section of the Information Center for the appropriate user response. Firmware Error : Sys Boot Status : X8 PCI 1 Firm : X8 PCI 2 Firm : X8 PCI 6 Firm : X8 PCI 7 Firm :

- **806f000f-220107ff : The System [ComputerSystemElementName] encountered firmware error - unrecoverable keyboard failure. (ABR Status)**

This message is for the use case when an implementation has detected that System Firmware Error Unrecoverable Keyboard failure has occurred.

May also be shown as 806f000f220107ff or 0x806f000f220107ff

**Severity**

Error

**Serviceable**

Yes

**Automatically notify support**

No

**Alert Category**

Critical - Other

**SNMP Trap ID**

50

**CIM Information**

**Prefix: PLAT ID:** 0764

**User Response**

This is a UEFI detected event. The UEFI(POST) error code for this event can be found in the logged IMM message text. Please refer to the UEFI(POST) error code in the "UEFI(POST) error code" section of the Information Center for the appropriate user response. Firmware Error : Sys Boot Status : X8 PCI 1 Firm : X8 PCI 2 Firm : X8 PCI 6 Firm : X8 PCI 7 Firm :

- **806f000f-22010aff : The System [ComputerSystemElementName] encountered firmware error - no video device detected. (ABR Status)**

This message is for the use case when an implementation has detected that System Firmware Error No video device detected has occurred.

May also be shown as 806f000f22010aff or 0x806f000f22010aff

**Severity**

Error

**Serviceable**

Yes

**Automatically notify support**

No

**Alert Category**

Critical - Other

**SNMP Trap ID**

50

**CIM Information**

**Prefix: PLAT ID:** 0766

**User Response**

This is a UEFI detected event. The UEFI(POST) error code for this event can be found in the logged IMM message text. Please refer to the UEFI(POST) error code in the "UEFI(POST) error code" section of the Information Center for the appropriate user response. Firmware Error : Sys Boot Status : X8 PCI 1 Firm : X8 PCI 2 Firm : X8 PCI 6 Firm : X8 PCI 7 Firm :



- **806f000f-22010bff : Firmware BIOS (ROM) corruption was detected on system [ComputerSystemElementName] during POST. (ABR Status)**

Firmware BIOS (ROM) corruption was detected on the system during POST.

May also be shown as 806f000f22010bff or 0x806f000f22010bff

**Severity**

Error

**Serviceable**

Yes

**Automatically notify support**

No

**Alert Category**

Critical - Other

**SNMP Trap ID**

50

**CIM Information**

**Prefix: PLAT ID:** 0850

**User Response**

1. Make sure the server meets the minimum configuration to start (see Power-supply LEDs).
2. Recover the server firmware from the backup page: a.Restart the server. b.At the prompt, press F3 to recover the firmware.
3. Update the server firmware to the latest level (see Updating the firmware). Important: Some cluster solutions require specific code levels or coordinated code updates. If the device is part of a cluster solution, verify that the latest level of code is supported for the cluster solution before you update the code.
4. Remove components one at a time, restarting the server each time, to see if the problem goes away.
5. If the problem remains, (trained service technician) replace the system board.

Firmware Error : Sys Boot Status : X8 PCI 1 Firm : X8 PCI 2 Firm : X8 PCI 6 Firm : X8 PCI 7 Firm :

- **806f000f-22010cff : CPU voltage mismatch detected on [ProcessorElementName]. (ABR Status)**

This message is for the use case when an implementation has detected a CPU voltage mismatch with the socket voltage.

May also be shown as 806f000f22010cff or 0x806f000f22010cff

**Severity**

Error

**Serviceable**

Yes

**Automatically notify support**

No

**Alert Category**

Critical - CPU

**SNMP Trap ID**

40

**CIM Information**

**Prefix: PLAT ID:** 0050

### User Response

This is a UEFI detected event. The UEFI(POST) error code for this event can be found in the logged IMM message text. Please refer to the UEFI(POST) error code in the "UEFI diagnostic code" section of the Info Center for the appropriate user response. Firmware Error : Sys Boot Status : X8 PCI 1 Firm : X8 PCI 2 Firm : X8 PCI 6 Firm : X8 PCI 7 Firm :

- **806f000f-2201ffff : The System [ComputerSystemElementName] encountered a POST Error. (ABR Status)**

This message is for the use case when an implementation has detected a Post Error.

May also be shown as 806f000f2201ffff or 0x806f000f2201ffff

### Severity

Error

### Serviceable

Yes

### Automatically notify support

No

### Alert Category

Critical - Other

### SNMP Trap ID

50

### CIM Information

Prefix: PLAT ID: 0184

### User Response

This is a UEFI detected event. The UEFI(POST) error code for this event can be found in the logged IMM message text. Please refer to the UEFI(POST) error code in the "UEFI(POST) error code" section of the Information Center for the appropriate user response. Firmware Error : Sys Boot Status : X8 PCI 1 Firm : X8 PCI 2 Firm : X8 PCI 6 Firm : X8 PCI 7 Firm :

- **806f0013-1701ffff : A diagnostic interrupt has occurred on system [ComputerSystemElementName]. (NMI State)**

This message is for the use case when an implementation has detected a Front Panel NMI / Diagnostic Interrupt.

May also be shown as 806f00131701ffff or 0x806f00131701ffff

### Severity

Error

### Serviceable

Yes

### Automatically notify support

No

### Alert Category

Critical - Other

### SNMP Trap ID

50

### CIM Information

Prefix: PLAT ID: 0222

### User Response

If the NMI button has not been pressed, complete the following steps:

1. Make sure that the NMI button is not pressed.
  2. Replace the operator information panel cable.
  3. Replace the operator information panel.
- **806f001e-2201ffff : No bootable media available for system [ComputerSystemElementName]. (No Boot Device)**

This message is for the use case when an implementation has detected a System with No Bootable Media.

May also be shown as 806f001e2201ffff or 0x806f001e2201ffff

**Severity**

Info

**Serviceable**

No

**Automatically notify support**

No

**Alert Category**

System - Other

**SNMP Trap ID**

**CIM Information**

Prefix: PLAT ID: 0286

**User Response**

No action; information only.

- **806f0021-2201ffff : Fault in slot [PhysicalConnectorSystemElementName] on system [ComputerSystemElementName]. (No Op ROM Space)**

This message is for the use case when an implementation has detected a Fault in a slot.

May also be shown as 806f00212201ffff or 0x806f00212201ffff

**Severity**

Error

**Serviceable**

Yes

**Automatically notify support**

Yes

**Alert Category**

Critical - Other

**SNMP Trap ID**

50

**CIM Information**

Prefix: PLAT ID: 0330

**User Response**

1. Check the PCI LED.
2. Reseat the affected adapters and riser card.
3. Update the server firmware (UEFI and IMM) and adapter firmware. Important: Some cluster solutions require specific code levels or coordinated code updates. If the device is part of a

cluster solution, verify that the latest level of code is supported for the cluster solution before you update the code.

4. Replace the affected adapters.
5. Replace the riser card.
6. (Trained service technicians only) Replace the system board.

- **806f0021-2582ffff : Fault in slot [PhysicalConnectorSystemElementName] on system [ComputerSystemElementName]. (All PCI Error)**

This message is for the use case when an implementation has detected a Fault in a slot.

May also be shown as 806f00212582ffff or 0x806f00212582ffff

**Severity**

Error

**Serviceable**

Yes

**Automatically notify support**

Yes

**Alert Category**

Critical - Other

**SNMP Trap ID**

50

**CIM Information**

**Prefix:** PLAT ID: 0330

**User Response**

1. Check the PCI LED.
2. Reseat the affected adapters and riser card.
3. Update the server firmware (UEFI and IMM) and adapter firmware. Important: Some cluster solutions require specific code levels or coordinated code updates. If the device is part of a cluster solution, verify that the latest level of code is supported for the cluster solution before you update the code.
4. Replace the affected adapters.
5. Replace the riser card.
6. (Trained service technicians only) Replace the system board.

One of PCI Error :

- **806f0021-2c01ffff : Fault in slot [PhysicalConnectorSystemElementName] on system [ComputerSystemElementName]. (ML2 Card Fault)**

This message is for the use case when an implementation has detected a Fault in a slot.

May also be shown as 806f00212c01ffff or 0x806f00212c01ffff

**Severity**

Error

**Serviceable**

Yes

**Automatically notify support**

Yes

**Alert Category**

Critical - Other

**SNMP Trap ID**

50

**CIM Information****Prefix:** PLAT ID: 0330**User Response**

1. Check the PCI LED.
  2. Reseat the affected adapters and riser card.
  3. Update the server firmware (UEFI and IMM) and adapter firmware. Important: Some cluster solutions require specific code levels or coordinated code updates. If the device is part of a cluster solution, verify that the latest level of code is supported for the cluster solution before you update the code.
  4. Replace the affected adapters.
  5. Replace the riser card.
  6. (Trained service technicians only) Replace the system board.
- **806f0021-3001ffff : Fault in slot [PhysicalConnectorSystemElementName] on system [ComputerSystemElementName]. (Internal RAID)**

This message is for the use case when an implementation has detected a Fault in a slot.

May also be shown as 806f00213001ffff or 0x806f00213001ffff

**Severity**

Error

**Serviceable**

Yes

**Automatically notify support**

Yes

**Alert Category**

Critical - Other

**SNMP Trap ID**

50

**CIM Information****Prefix:** PLAT ID: 0330**User Response**

1. Check the PCI LED.
  2. Reseat the affected adapters and riser card.
  3. Update the server firmware (UEFI and IMM) and adapter firmware. Important: Some cluster solutions require specific code levels or coordinated code updates. If the device is part of a cluster solution, verify that the latest level of code is supported for the cluster solution before you update the code.
  4. Replace the affected adapters.
  5. Replace the riser card.
  6. (Trained service technicians only) Replace the system board.
- PCI 1 : PCI 2 : PCI 3 : PCI 4 : PCI 5 : PCI 6 : PCI 7 : PCI 8 :
- **806f0023-2101ffff : Watchdog Timer expired for [WatchdogElementName]. (IPMI Watchdog)**

This message is for the use case when an implementation has detected a Watchdog Timer Expired.

May also be shown as 806f00232101ffff or 0x806f00232101ffff

**Severity**

Info

**Serviceable**

No

**Automatically notify support**

No

**Alert Category**

System - Other

**SNMP Trap ID****CIM Information**

Prefix: PLAT ID: 0368

**User Response**

No action; information only.

- **806f0028-2101ffff : Sensor [SensorElementName] is unavailable or degraded on management system [ComputerSystemElementName]. (TPM Cmd Failures)**

This message is for the use case when an implementation has detected a Sensor is Unavailable or degraded.

May also be shown as 806f00282101ffff or 0x806f00282101ffff

**Severity**

Warning

**Serviceable**

Yes

**Automatically notify support**

No

**Alert Category**

Warning - Other

**SNMP Trap ID**

60

**CIM Information**

Prefix: PLAT ID: 0398

**User Response**

1. Turn off the server and disconnect the power cords. Reconnect the power cords and restart the server.
  2. If the problem remains, (trained technician only) replace the system board.
- **806f0107-0301ffff : An Over-Temperature Condition has been detected on [ProcessorElementName]. (CPU 1)**

This message is for the use case when an implementation has detected an Over-Temperature Condition Detected for Processor.

May also be shown as 806f01070301ffff or 0x806f01070301ffff

**Severity**

Error

**Serviceable**

Yes

**Automatically notify support**

No

**Alert Category**

Critical - Temperature

**SNMP Trap ID**

0

**CIM Information**

Prefix: PLAT ID: 0036

**User Response**

1. Make sure that the fans are operating. There are no obstructions to the airflow (front and rear of the server), the air baffles are in place and correctly installed, and the server cover is installed and completely closed.
  2. Make sure that the heat sink for microprocessor n is installed correctly.
  3. (Trained technician only) Replace microprocessor n. (n = microprocessor number)
- **806f0107-0302ffff : An Over-Temperature Condition has been detected on [ProcessorElementName]. (CPU 2)**

This message is for the use case when an implementation has detected an Over-Temperature Condition Detected for Processor.

May also be shown as 806f01070302ffff or 0x806f01070302ffff

**Severity**

Error

**Serviceable**

Yes

**Automatically notify support**

No

**Alert Category**

Critical - Temperature

**SNMP Trap ID**

0

**CIM Information**

Prefix: PLAT ID: 0036

**User Response**

1. Make sure that the fans are operating. There are no obstructions to the airflow (front and rear of the server), the air baffles are in place and correctly installed, and the server cover is installed and completely closed.
  2. Make sure that the heat sink for microprocessor n is installed correctly.
  3. (Trained technician only) Replace microprocessor n. (n = microprocessor number)
- **806f0108-0a01ffff : [PowerSupplyElementName] has Failed. (Power Supply 1)**

This message is for the use case when an implementation has detected a Power Supply has failed.

May also be shown as 806f01080a01ffff or 0x806f01080a01ffff

**Severity**

Error

**Serviceable**

Yes

**Automatically notify support**

Yes

**Alert Category**

Critical - Power

**SNMP Trap ID**

4

**CIM Information**

**Prefix:** PLAT ID: 0086

**User Response**

1. Reseat power supply n.
2. If the power-on LED is not lit and the power-supply error LED is lit, replace power supply n.
3. If both the power-on LED and the power-supply error LED are not lit, see Power problems for more information. (n = power supply number)

- **806f0108-0a02ffff : [PowerSupplyElementName] has Failed. (Power Supply 2)**

This message is for the use case when an implementation has detected a Power Supply has failed.

May also be shown as 806f01080a02ffff or 0x806f01080a02ffff

**Severity**

Error

**Serviceable**

Yes

**Automatically notify support**

Yes

**Alert Category**

Critical - Power

**SNMP Trap ID**

4

**CIM Information**

**Prefix:** PLAT ID: 0086

**User Response**

1. Reseat power supply n.
2. If the power-on LED is not lit and the power-supply error LED is lit, replace power supply n.
3. If both the power-on LED and the power-supply error LED are not lit, see Power problems for more information. (n = power supply number)

- **806f0109-1301ffff : [PowerSupplyElementName] has been Power Cycled. (Host Power)**

This message is for the use case when an implementation has detected a Power Unit that has been power cycled.

May also be shown as 806f01091301ffff or 0x806f01091301ffff

**Severity**

Info

**Serviceable**

No

**Automatically notify support**

No



**Alert Category**

System - Other

**SNMP Trap ID****CIM Information**

Prefix: PLAT ID: 0108

**User Response**

No action; information only.

- **806f010c-2001ffff : Uncorrectable error detected for [PhysicalMemoryElementName] on Subsystem [MemoryElementName]. (DIMM 1)**

This message is for the use case when an implementation has detected a Memory uncorrectable error.

May also be shown as 806f010c2001ffff or 0x806f010c2001ffff

**Severity**

Error

**Serviceable**

Yes

**Automatically notify support**

Yes

**Alert Category**

Critical - Memory

**SNMP Trap ID**

41

**CIM Information**

Prefix: PLAT ID: 0138

**User Response**

Note: Each time you install or remove a DIMM, you must disconnect the server from the power source; then, wait 10 seconds before restarting the server.

1. Refer to TIP H212293 for minimum code level.
  2. Check the Lenovo support website for an applicable retain tip or firmware update that applies to this memory error.
  3. Swap the affected DIMMs (as indicated by the error LEDs on the system board or the event logs) to a different memory channel or microprocessor.
  4. If the problem follows the DIMM, replace the failing DIMM.
  5. (Trained technician only) If the problem occurs on the same DIMM connector, check the DIMM connector. If the connector contains any foreign material or is damaged, replace the system board.
  6. (Trained technician only) Remove the affected microprocessor and check the microprocessor socket pins for any damaged pins. If a damage is found, replace the system board.
  7. (Trained technician only) Replace the affected microprocessor.
  8. Manually re-enable all affected DIMMs if the server firmware version is older than UEFI v1.10. If the server firmware version is UEFI v1.10 or newer, disconnect and reconnect the server to the power source and restart the server.
  9. (Trained Service technician only) Replace the affected microprocessor.
- **806f010c-2002ffff : Uncorrectable error detected for [PhysicalMemoryElementName] on Subsystem [MemoryElementName]. (DIMM 2)**

This message is for the use case when an implementation has detected a Memory uncorrectable error. May also be shown as 806f010c2002ffff or 0x806f010c2002ffff

**Severity**

Error

**Serviceable**

Yes

**Automatically notify support**

Yes

**Alert Category**

Critical - Memory

**SNMP Trap ID**

41

**CIM Information**

Prefix: PLAT ID: 0138

**User Response**

Note: Each time you install or remove a DIMM, you must disconnect the server from the power source; then, wait 10 seconds before restarting the server.

1. Refer to TIP H212293 for minimum code level.
  2. Check the Lenovo support website for an applicable retain tip or firmware update that applies to this memory error.
  3. Swap the affected DIMMs (as indicated by the error LEDs on the system board or the event logs) to a different memory channel or microprocessor.
  4. If the problem follows the DIMM, replace the failing DIMM.
  5. (Trained technician only) If the problem occurs on the same DIMM connector, check the DIMM connector. If the connector contains any foreign material or is damaged, replace the system board.
  6. (Trained technician only) Remove the affected microprocessor and check the microprocessor socket pins for any damaged pins. If a damage is found, replace the system board.
  7. (Trained technician only) Replace the affected microprocessor.
  8. Manually re-enable all affected DIMMs if the server firmware version is older than UEFI v1.10. If the server firmware version is UEFI v1.10 or newer, disconnect and reconnect the server to the power source and restart the server.
  9. (Trained Service technician only) Replace the affected microprocessor.
- **806f010c-2003ffff : Uncorrectable error detected for [PhysicalMemoryElementName] on Subsystem [MemoryElementName]. (DIMM 3)**

This message is for the use case when an implementation has detected a Memory uncorrectable error. May also be shown as 806f010c2003ffff or 0x806f010c2003ffff

**Severity**

Error

**Serviceable**

Yes

**Automatically notify support**

Yes

**Alert Category**

Critical - Memory

**SNMP Trap ID**

41

**CIM Information**

**Prefix:** PLAT ID: 0138

**User Response**

Note: Each time you install or remove a DIMM, you must disconnect the server from the power source; then, wait 10 seconds before restarting the server.

1. Refer to TIP H212293 for minimum code level.
  2. Check the Lenovo support website for an applicable retain tip or firmware update that applies to this memory error.
  3. Swap the affected DIMMs (as indicated by the error LEDs on the system board or the event logs) to a different memory channel or microprocessor.
  4. If the problem follows the DIMM, replace the failing DIMM.
  5. (Trained technician only) If the problem occurs on the same DIMM connector, check the DIMM connector. If the connector contains any foreign material or is damaged, replace the system board.
  6. (Trained technician only) Remove the affected microprocessor and check the microprocessor socket pins for any damaged pins. If a damage is found, replace the system board.
  7. (Trained technician only) Replace the affected microprocessor.
  8. Manually re-enable all affected DIMMs if the server firmware version is older than UEFI v1.10. If the server firmware version is UEFI v1.10 or newer, disconnect and reconnect the server to the power source and restart the server.
  9. (Trained Service technician only) Replace the affected microprocessor.
- **806f010c-2004ffff : Uncorrectable error detected for [PhysicalMemoryElementName] on Subsystem [MemoryElementName]. (DIMM 4)**

This message is for the use case when an implementation has detected a Memory uncorrectable error.

May also be shown as 806f010c2004ffff or 0x806f010c2004ffff

**Severity**

Error

**Serviceable**

Yes

**Automatically notify support**

Yes

**Alert Category**

Critical - Memory

**SNMP Trap ID**

41

**CIM Information**

**Prefix:** PLAT ID: 0138

**User Response**

Note: Each time you install or remove a DIMM, you must disconnect the server from the power source; then, wait 10 seconds before restarting the server.

1. Refer to TIP H212293 for minimum code level.

2. Check the Lenovo support website for an applicable retain tip or firmware update that applies to this memory error.
3. Swap the affected DIMMs (as indicated by the error LEDs on the system board or the event logs) to a different memory channel or microprocessor.
4. If the problem follows the DIMM, replace the failing DIMM.
5. (Trained technician only) If the problem occurs on the same DIMM connector, check the DIMM connector. If the connector contains any foreign material or is damaged, replace the system board.
6. (Trained technician only) Remove the affected microprocessor and check the microprocessor socket pins for any damaged pins. If a damage is found, replace the system board.
7. (Trained technician only) Replace the affected microprocessor.
8. Manually re-enable all affected DIMMs if the server firmware version is older than UEFI v1.10. If the server firmware version is UEFI v1.10 or newer, disconnect and reconnect the server to the power source and restart the server.
9. (Trained Service technician only) Replace the affected microprocessor.

- **806f010c-2005ffff : Uncorrectable error detected for [PhysicalMemoryElementName] on Subsystem [MemoryElementName]. (DIMM 5)**

This message is for the use case when an implementation has detected a Memory uncorrectable error. May also be shown as 806f010c2005ffff or 0x806f010c2005ffff

**Severity**

Error

**Serviceable**

Yes

**Automatically notify support**

Yes

**Alert Category**

Critical - Memory

**SNMP Trap ID**

41

**CIM Information**

**Prefix:** PLAT ID: 0138

**User Response**

Note: Each time you install or remove a DIMM, you must disconnect the server from the power source; then, wait 10 seconds before restarting the server.

1. Refer to TIP H212293 for minimum code level.
2. Check the Lenovo support website for an applicable retain tip or firmware update that applies to this memory error.
3. Swap the affected DIMMs (as indicated by the error LEDs on the system board or the event logs) to a different memory channel or microprocessor.
4. If the problem follows the DIMM, replace the failing DIMM.
5. (Trained technician only) If the problem occurs on the same DIMM connector, check the DIMM connector. If the connector contains any foreign material or is damaged, replace the system board.
6. (Trained technician only) Remove the affected microprocessor and check the microprocessor socket pins for any damaged pins. If a damage is found, replace the system board.

7. (Trained technician only) Replace the affected microprocessor.
  8. Manually re-enable all affected DIMMs if the server firmware version is older than UEFI v1.10. If the server firmware version is UEFI v1.10 or newer, disconnect and reconnect the server to the power source and restart the server.
  9. (Trained Service technician only) Replace the affected microprocessor.
- **806f010c-2006ffff : Uncorrectable error detected for [PhysicalMemoryElementName] on Subsystem [MemoryElementName]. (DIMM 6)**

This message is for the use case when an implementation has detected a Memory uncorrectable error. May also be shown as 806f010c2006ffff or 0x806f010c2006ffff

**Severity**

Error

**Serviceable**

Yes

**Automatically notify support**

Yes

**Alert Category**

Critical - Memory

**SNMP Trap ID**

41

**CIM Information**

**Prefix:** PLAT ID: 0138

**User Response**

Note: Each time you install or remove a DIMM, you must disconnect the server from the power source; then, wait 10 seconds before restarting the server.

1. Refer to TIP H212293 for minimum code level.
  2. Check the Lenovo support website for an applicable retain tip or firmware update that applies to this memory error.
  3. Swap the affected DIMMs (as indicated by the error LEDs on the system board or the event logs) to a different memory channel or microprocessor.
  4. If the problem follows the DIMM, replace the failing DIMM.
  5. (Trained technician only) If the problem occurs on the same DIMM connector, check the DIMM connector. If the connector contains any foreign material or is damaged, replace the system board.
  6. (Trained technician only) Remove the affected microprocessor and check the microprocessor socket pins for any damaged pins. If a damage is found, replace the system board.
  7. (Trained technician only) Replace the affected microprocessor.
  8. Manually re-enable all affected DIMMs if the server firmware version is older than UEFI v1.10. If the server firmware version is UEFI v1.10 or newer, disconnect and reconnect the server to the power source and restart the server.
  9. (Trained Service technician only) Replace the affected microprocessor.
- **806f010c-2007ffff : Uncorrectable error detected for [PhysicalMemoryElementName] on Subsystem [MemoryElementName]. (DIMM 7)**

This message is for the use case when an implementation has detected a Memory uncorrectable error. May also be shown as 806f010c2007ffff or 0x806f010c2007ffff

**Severity**

Error

**Serviceable**

Yes

**Automatically notify support**

Yes

**Alert Category**

Critical - Memory

**SNMP Trap ID**

41

**CIM Information**

**Prefix: PLAT ID:** 0138

**User Response**

Note: Each time you install or remove a DIMM, you must disconnect the server from the power source; then, wait 10 seconds before restarting the server.

1. Refer to TIP H212293 for minimum code level.
2. Check the Lenovo support website for an applicable retain tip or firmware update that applies to this memory error.
3. Swap the affected DIMMs (as indicated by the error LEDs on the system board or the event logs) to a different memory channel or microprocessor.
4. If the problem follows the DIMM, replace the failing DIMM.
5. (Trained technician only) If the problem occurs on the same DIMM connector, check the DIMM connector. If the connector contains any foreign material or is damaged, replace the system board.
6. (Trained technician only) Remove the affected microprocessor and check the microprocessor socket pins for any damaged pins. If a damage is found, replace the system board.
7. (Trained technician only) Replace the affected microprocessor.
8. Manually re-enable all affected DIMMs if the server firmware version is older than UEFI v1.10. If the server firmware version is UEFI v1.10 or newer, disconnect and reconnect the server to the power source and restart the server.
9. (Trained Service technician only) Replace the affected microprocessor.

- **806f010c-2008ffff : Uncorrectable error detected for [PhysicalMemoryElementName] on Subsystem [MemoryElementName]. (DIMM 8)**

This message is for the use case when an implementation has detected a Memory uncorrectable error.

May also be shown as 806f010c2008ffff or 0x806f010c2008ffff

**Severity**

Error

**Serviceable**

Yes

**Automatically notify support**

Yes

**Alert Category**

Critical - Memory

**SNMP Trap ID**

41

**CIM Information**

**Prefix:** PLAT ID: 0138

### User Response

Note: Each time you install or remove a DIMM, you must disconnect the server from the power source; then, wait 10 seconds before restarting the server.

1. Refer to TIP H212293 for minimum code level.
  2. Check the Lenovo support website for an applicable retain tip or firmware update that applies to this memory error.
  3. Swap the affected DIMMs (as indicated by the error LEDs on the system board or the event logs) to a different memory channel or microprocessor.
  4. If the problem follows the DIMM, replace the failing DIMM.
  5. (Trained technician only) If the problem occurs on the same DIMM connector, check the DIMM connector. If the connector contains any foreign material or is damaged, replace the system board.
  6. (Trained technician only) Remove the affected microprocessor and check the microprocessor socket pins for any damaged pins. If a damage is found, replace the system board.
  7. (Trained technician only) Replace the affected microprocessor.
  8. Manually re-enable all affected DIMMs if the server firmware version is older than UEFI v1.10. If the server firmware version is UEFI v1.10 or newer, disconnect and reconnect the server to the power source and restart the server.
  9. (Trained Service technician only) Replace the affected microprocessor.
- **806f010c-2009ffff : Uncorrectable error detected for [PhysicalMemoryElementName] on Subsystem [MemoryElementName]. (DIMM 9)**

This message is for the use case when an implementation has detected a Memory uncorrectable error.

May also be shown as 806f010c2009ffff or 0x806f010c2009ffff

### Severity

Error

### Serviceable

Yes

### Automatically notify support

Yes

### Alert Category

Critical - Memory

### SNMP Trap ID

41

### CIM Information

**Prefix:** PLAT ID: 0138

### User Response

Note: Each time you install or remove a DIMM, you must disconnect the server from the power source; then, wait 10 seconds before restarting the server.

1. Refer to TIP H212293 for minimum code level.
2. Check the Lenovo support website for an applicable retain tip or firmware update that applies to this memory error.
3. Swap the affected DIMMs (as indicated by the error LEDs on the system board or the event logs) to a different memory channel or microprocessor.
4. If the problem follows the DIMM, replace the failing DIMM.

5. (Trained technician only) If the problem occurs on the same DIMM connector, check the DIMM connector. If the connector contains any foreign material or is damaged, replace the system board.
6. (Trained technician only) Remove the affected microprocessor and check the microprocessor socket pins for any damaged pins. If a damage is found, replace the system board.
7. (Trained technician only) Replace the affected microprocessor.
8. Manually re-enable all affected DIMMs if the server firmware version is older than UEFI v1.10. If the server firmware version is UEFI v1.10 or newer, disconnect and reconnect the server to the power source and restart the server.
9. (Trained Service technician only) Replace the affected microprocessor.

- **806f010c-200affff : Uncorrectable error detected for [PhysicalMemoryElementName] on Subsystem [MemoryElementName]. (DIMM 10)**

This message is for the use case when an implementation has detected a Memory uncorrectable error.

May also be shown as 806f010c200affff or 0x806f010c200affff

**Severity**

Error

**Serviceable**

Yes

**Automatically notify support**

Yes

**Alert Category**

Critical - Memory

**SNMP Trap ID**

41

**CIM Information**

**Prefix:** PLAT ID: 0138

**User Response**

Note: Each time you install or remove a DIMM, you must disconnect the server from the power source; then, wait 10 seconds before restarting the server.

1. Refer to TIP H212293 for minimum code level.
2. Check the Lenovo support website for an applicable retain tip or firmware update that applies to this memory error.
3. Swap the affected DIMMs (as indicated by the error LEDs on the system board or the event logs) to a different memory channel or microprocessor.
4. If the problem follows the DIMM, replace the failing DIMM.
5. (Trained technician only) If the problem occurs on the same DIMM connector, check the DIMM connector. If the connector contains any foreign material or is damaged, replace the system board.
6. (Trained technician only) Remove the affected microprocessor and check the microprocessor socket pins for any damaged pins. If a damage is found, replace the system board.
7. (Trained technician only) Replace the affected microprocessor.
8. Manually re-enable all affected DIMMs if the server firmware version is older than UEFI v1.10. If the server firmware version is UEFI v1.10 or newer, disconnect and reconnect the server to the power source and restart the server.
9. (Trained Service technician only) Replace the affected microprocessor.



- **806f010c-200bffff : Uncorrectable error detected for [PhysicalMemoryElementName] on Subsystem [MemoryElementName]. (DIMM 11)**

This message is for the use case when an implementation has detected a Memory uncorrectable error.

May also be shown as 806f010c200bffff or 0x806f010c200bffff

**Severity**

Error

**Serviceable**

Yes

**Automatically notify support**

Yes

**Alert Category**

Critical - Memory

**SNMP Trap ID**

41

**CIM Information**

**Prefix:** PLAT ID: 0138

**User Response**

Note: Each time you install or remove a DIMM, you must disconnect the server from the power source; then, wait 10 seconds before restarting the server.

1. Refer to TIP H212293 for minimum code level.
2. Check the Lenovo support website for an applicable retain tip or firmware update that applies to this memory error.
3. Swap the affected DIMMs (as indicated by the error LEDs on the system board or the event logs) to a different memory channel or microprocessor.
4. If the problem follows the DIMM, replace the failing DIMM.
5. (Trained technician only) If the problem occurs on the same DIMM connector, check the DIMM connector. If the connector contains any foreign material or is damaged, replace the system board.
6. (Trained technician only) Remove the affected microprocessor and check the microprocessor socket pins for any damaged pins. If a damage is found, replace the system board.
7. (Trained technician only) Replace the affected microprocessor.
8. Manually re-enable all affected DIMMs if the server firmware version is older than UEFI v1.10. If the server firmware version is UEFI v1.10 or newer, disconnect and reconnect the server to the power source and restart the server.
9. (Trained Service technician only) Replace the affected microprocessor.

- **806f010c-200cffff : Uncorrectable error detected for [PhysicalMemoryElementName] on Subsystem [MemoryElementName]. (DIMM 12)**

This message is for the use case when an implementation has detected a Memory uncorrectable error.

May also be shown as 806f010c200cffff or 0x806f010c200cffff

**Severity**

Error

**Serviceable**

Yes

**Automatically notify support**

Yes

**Alert Category**

Critical - Memory

**SNMP Trap ID**

41

**CIM Information**

**Prefix:** PLAT ID: 0138

**User Response**

Note: Each time you install or remove a DIMM, you must disconnect the server from the power source; then, wait 10 seconds before restarting the server.

1. Refer to TIP H212293 for minimum code level.
2. Check the Lenovo support website for an applicable retain tip or firmware update that applies to this memory error.
3. Swap the affected DIMMs (as indicated by the error LEDs on the system board or the event logs) to a different memory channel or microprocessor.
4. If the problem follows the DIMM, replace the failing DIMM.
5. (Trained technician only) If the problem occurs on the same DIMM connector, check the DIMM connector. If the connector contains any foreign material or is damaged, replace the system board.
6. (Trained technician only) Remove the affected microprocessor and check the microprocessor socket pins for any damaged pins. If a damage is found, replace the system board.
7. (Trained technician only) Replace the affected microprocessor.
8. Manually re-enable all affected DIMMs if the server firmware version is older than UEFI v1.10. If the server firmware version is UEFI v1.10 or newer, disconnect and reconnect the server to the power source and restart the server.
9. (Trained Service technician only) Replace the affected microprocessor.

- **806f010c-200dffff : Uncorrectable error detected for [PhysicalMemoryElementName] on Subsystem [MemoryElementName]. (DIMM 13)**

This message is for the use case when an implementation has detected a Memory uncorrectable error.

May also be shown as 806f010c200dffff or 0x806f010c200dffff

**Severity**

Error

**Serviceable**

Yes

**Automatically notify support**

Yes

**Alert Category**

Critical - Memory

**SNMP Trap ID**

41

**CIM Information**

**Prefix:** PLAT ID: 0138

**User Response**

Note: Each time you install or remove a DIMM, you must disconnect the server from the power source; then, wait 10 seconds before restarting the server.

1. Refer to TIP H212293 for minimum code level.
  2. Check the Lenovo support website for an applicable retain tip or firmware update that applies to this memory error.
  3. Swap the affected DIMMs (as indicated by the error LEDs on the system board or the event logs) to a different memory channel or microprocessor.
  4. If the problem follows the DIMM, replace the failing DIMM.
  5. (Trained technician only) If the problem occurs on the same DIMM connector, check the DIMM connector. If the connector contains any foreign material or is damaged, replace the system board.
  6. (Trained technician only) Remove the affected microprocessor and check the microprocessor socket pins for any damaged pins. If a damage is found, replace the system board.
  7. (Trained technician only) Replace the affected microprocessor.
  8. Manually re-enable all affected DIMMs if the server firmware version is older than UEFI v1.10. If the server firmware version is UEFI v1.10 or newer, disconnect and reconnect the server to the power source and restart the server.
  9. (Trained Service technician only) Replace the affected microprocessor.
- **806f010c-200effff : Uncorrectable error detected for [PhysicalMemoryElementName] on Subsystem [MemoryElementName]. (DIMM 14)**

This message is for the use case when an implementation has detected a Memory uncorrectable error. May also be shown as 806f010c200effff or 0x806f010c200effff

**Severity**

Error

**Serviceable**

Yes

**Automatically notify support**

Yes

**Alert Category**

Critical - Memory

**SNMP Trap ID**

41

**CIM Information**

**Prefix: PLAT ID:** 0138

**User Response**

Note: Each time you install or remove a DIMM, you must disconnect the server from the power source; then, wait 10 seconds before restarting the server.

1. Refer to TIP H212293 for minimum code level.
2. Check the Lenovo support website for an applicable retain tip or firmware update that applies to this memory error.
3. Swap the affected DIMMs (as indicated by the error LEDs on the system board or the event logs) to a different memory channel or microprocessor.
4. If the problem follows the DIMM, replace the failing DIMM.
5. (Trained technician only) If the problem occurs on the same DIMM connector, check the DIMM connector. If the connector contains any foreign material or is damaged, replace the system board.

6. (Trained technician only) Remove the affected microprocessor and check the microprocessor socket pins for any damaged pins. If a damage is found, replace the system board.
  7. (Trained technician only) Replace the affected microprocessor.
  8. Manually re-enable all affected DIMMs if the server firmware version is older than UEFI v1.10. If the server firmware version is UEFI v1.10 or newer, disconnect and reconnect the server to the power source and restart the server.
  9. (Trained Service technician only) Replace the affected microprocessor.
- **806f010c-200ffff : Uncorrectable error detected for [PhysicalMemoryElementName] on Subsystem [MemoryElementName]. (DIMM 15)**

This message is for the use case when an implementation has detected a Memory uncorrectable error. May also be shown as 806f010c200ffff or 0x806f010c200ffff

**Severity**

Error

**Serviceable**

Yes

**Automatically notify support**

Yes

**Alert Category**

Critical - Memory

**SNMP Trap ID**

41

**CIM Information**

**Prefix:** PLAT ID: 0138

**User Response**

Note: Each time you install or remove a DIMM, you must disconnect the server from the power source; then, wait 10 seconds before restarting the server.

1. Refer to TIP H212293 for minimum code level.
  2. Check the Lenovo support website for an applicable retain tip or firmware update that applies to this memory error.
  3. Swap the affected DIMMs (as indicated by the error LEDs on the system board or the event logs) to a different memory channel or microprocessor.
  4. If the problem follows the DIMM, replace the failing DIMM.
  5. (Trained technician only) If the problem occurs on the same DIMM connector, check the DIMM connector. If the connector contains any foreign material or is damaged, replace the system board.
  6. (Trained technician only) Remove the affected microprocessor and check the microprocessor socket pins for any damaged pins. If a damage is found, replace the system board.
  7. (Trained technician only) Replace the affected microprocessor.
  8. Manually re-enable all affected DIMMs if the server firmware version is older than UEFI v1.10. If the server firmware version is UEFI v1.10 or newer, disconnect and reconnect the server to the power source and restart the server.
  9. (Trained Service technician only) Replace the affected microprocessor.
- **806f010c-2010ffff : Uncorrectable error detected for [PhysicalMemoryElementName] on Subsystem [MemoryElementName]. (DIMM 16)**

This message is for the use case when an implementation has detected a Memory uncorrectable error.

May also be shown as 806f010c2010ffff or 0x806f010c2010ffff

**Severity**

Error

**Serviceable**

Yes

**Automatically notify support**

Yes

**Alert Category**

Critical - Memory

**SNMP Trap ID**

41

**CIM Information**

**Prefix: PLAT ID:** 0138

**User Response**

Note: Each time you install or remove a DIMM, you must disconnect the server from the power source; then, wait 10 seconds before restarting the server.

1. Refer to TIP H212293 for minimum code level.
  2. Check the Lenovo support website for an applicable retain tip or firmware update that applies to this memory error.
  3. Swap the affected DIMMs (as indicated by the error LEDs on the system board or the event logs) to a different memory channel or microprocessor.
  4. If the problem follows the DIMM, replace the failing DIMM.
  5. (Trained technician only) If the problem occurs on the same DIMM connector, check the DIMM connector. If the connector contains any foreign material or is damaged, replace the system board.
  6. (Trained technician only) Remove the affected microprocessor and check the microprocessor socket pins for any damaged pins. If a damage is found, replace the system board.
  7. (Trained technician only) Replace the affected microprocessor.
  8. Manually re-enable all affected DIMMs if the server firmware version is older than UEFI v1.10. If the server firmware version is UEFI v1.10 or newer, disconnect and reconnect the server to the power source and restart the server.
  9. (Trained Service technician only) Replace the affected microprocessor.
- **806f010c-2011ffff : Uncorrectable error detected for [PhysicalMemoryElementName] on Subsystem [MemoryElementName]. (DIMM 17)**

This message is for the use case when an implementation has detected a Memory uncorrectable error.

May also be shown as 806f010c2011ffff or 0x806f010c2011ffff

**Severity**

Error

**Serviceable**

Yes

**Automatically notify support**

Yes

**Alert Category**

Critical - Memory

**SNMP Trap ID**

41

**CIM Information****Prefix:** PLAT ID: 0138**User Response**

Note: Each time you install or remove a DIMM, you must disconnect the server from the power source; then, wait 10 seconds before restarting the server.

1. Refer to TIP H212293 for minimum code level.
  2. Check the Lenovo support website for an applicable retain tip or firmware update that applies to this memory error.
  3. Swap the affected DIMMs (as indicated by the error LEDs on the system board or the event logs) to a different memory channel or microprocessor.
  4. If the problem follows the DIMM, replace the failing DIMM.
  5. (Trained technician only) If the problem occurs on the same DIMM connector, check the DIMM connector. If the connector contains any foreign material or is damaged, replace the system board.
  6. (Trained technician only) Remove the affected microprocessor and check the microprocessor socket pins for any damaged pins. If a damage is found, replace the system board.
  7. (Trained technician only) Replace the affected microprocessor.
  8. Manually re-enable all affected DIMMs if the server firmware version is older than UEFI v1.10. If the server firmware version is UEFI v1.10 or newer, disconnect and reconnect the server to the power source and restart the server.
  9. (Trained Service technician only) Replace the affected microprocessor.
- **806f010c-2012ffff : Uncorrectable error detected for [PhysicalMemoryElementName] on Subsystem [MemoryElementName]. (DIMM 18)**

This message is for the use case when an implementation has detected a Memory uncorrectable error.

May also be shown as 806f010c2012ffff or 0x806f010c2012ffff

**Severity**

Error

**Serviceable**

Yes

**Automatically notify support**

Yes

**Alert Category**

Critical - Memory

**SNMP Trap ID**

41

**CIM Information****Prefix:** PLAT ID: 0138**User Response**

Note: Each time you install or remove a DIMM, you must disconnect the server from the power source; then, wait 10 seconds before restarting the server.

1. Refer to TIP H212293 for minimum code level.
2. Check the Lenovo support website for an applicable retain tip or firmware update that applies to this memory error.

3. Swap the affected DIMMs (as indicated by the error LEDs on the system board or the event logs) to a different memory channel or microprocessor.
4. If the problem follows the DIMM, replace the failing DIMM.
5. (Trained technician only) If the problem occurs on the same DIMM connector, check the DIMM connector. If the connector contains any foreign material or is damaged, replace the system board.
6. (Trained technician only) Remove the affected microprocessor and check the microprocessor socket pins for any damaged pins. If a damage is found, replace the system board.
7. (Trained technician only) Replace the affected microprocessor.
8. Manually re-enable all affected DIMMs if the server firmware version is older than UEFI v1.10. If the server firmware version is UEFI v1.10 or newer, disconnect and reconnect the server to the power source and restart the server.
9. (Trained Service technician only) Replace the affected microprocessor.

- **806f010c-2013ffff : Uncorrectable error detected for [PhysicalMemoryElementName] on Subsystem [MemoryElementName]. (DIMM 19)**

This message is for the use case when an implementation has detected a Memory uncorrectable error.

May also be shown as 806f010c2013ffff or 0x806f010c2013ffff

**Severity**

Error

**Serviceable**

Yes

**Automatically notify support**

Yes

**Alert Category**

Critical - Memory

**SNMP Trap ID**

41

**CIM Information**

**Prefix:** PLAT ID: 0138

**User Response**

Note: Each time you install or remove a DIMM, you must disconnect the server from the power source; then, wait 10 seconds before restarting the server.

1. Refer to TIP H212293 for minimum code level.
2. Check the Lenovo support website for an applicable retain tip or firmware update that applies to this memory error.
3. Swap the affected DIMMs (as indicated by the error LEDs on the system board or the event logs) to a different memory channel or microprocessor.
4. If the problem follows the DIMM, replace the failing DIMM.
5. (Trained technician only) If the problem occurs on the same DIMM connector, check the DIMM connector. If the connector contains any foreign material or is damaged, replace the system board.
6. (Trained technician only) Remove the affected microprocessor and check the microprocessor socket pins for any damaged pins. If a damage is found, replace the system board.
7. (Trained technician only) Replace the affected microprocessor.

8. Manually re-enable all affected DIMMs if the server firmware version is older than UEFI v1.10. If the server firmware version is UEFI v1.10 or newer, disconnect and reconnect the server to the power source and restart the server.
9. (Trained Service technician only) Replace the affected microprocessor.

- **806f010c-2014ffff : Uncorrectable error detected for [PhysicalMemoryElementName] on Subsystem [MemoryElementName]. (DIMM 20)**

This message is for the use case when an implementation has detected a Memory uncorrectable error.

May also be shown as 806f010c2014ffff or 0x806f010c2014ffff

**Severity**

Error

**Serviceable**

Yes

**Automatically notify support**

Yes

**Alert Category**

Critical - Memory

**SNMP Trap ID**

41

**CIM Information**

**Prefix: PLAT ID:** 0138

**User Response**

Note: Each time you install or remove a DIMM, you must disconnect the server from the power source; then, wait 10 seconds before restarting the server.

1. Refer to TIP H212293 for minimum code level.
2. Check the Lenovo support website for an applicable retain tip or firmware update that applies to this memory error.
3. Swap the affected DIMMs (as indicated by the error LEDs on the system board or the event logs) to a different memory channel or microprocessor.
4. If the problem follows the DIMM, replace the failing DIMM.
5. (Trained technician only) If the problem occurs on the same DIMM connector, check the DIMM connector. If the connector contains any foreign material or is damaged, replace the system board.
6. (Trained technician only) Remove the affected microprocessor and check the microprocessor socket pins for any damaged pins. If a damage is found, replace the system board.
7. (Trained technician only) Replace the affected microprocessor.
8. Manually re-enable all affected DIMMs if the server firmware version is older than UEFI v1.10. If the server firmware version is UEFI v1.10 or newer, disconnect and reconnect the server to the power source and restart the server.
9. (Trained Service technician only) Replace the affected microprocessor.

- **806f010c-2015ffff : Uncorrectable error detected for [PhysicalMemoryElementName] on Subsystem [MemoryElementName]. (DIMM 21)**

This message is for the use case when an implementation has detected a Memory uncorrectable error.

May also be shown as 806f010c2015ffff or 0x806f010c2015ffff

**Severity**

Error



**Serviceable**

Yes

**Automatically notify support**

Yes

**Alert Category**

Critical - Memory

**SNMP Trap ID**

41

**CIM Information****Prefix:** PLAT ID: 0138**User Response**

Note: Each time you install or remove a DIMM, you must disconnect the server from the power source; then, wait 10 seconds before restarting the server.

1. Refer to TIP H212293 for minimum code level.
  2. Check the Lenovo support website for an applicable retain tip or firmware update that applies to this memory error.
  3. Swap the affected DIMMs (as indicated by the error LEDs on the system board or the event logs) to a different memory channel or microprocessor.
  4. If the problem follows the DIMM, replace the failing DIMM.
  5. (Trained technician only) If the problem occurs on the same DIMM connector, check the DIMM connector. If the connector contains any foreign material or is damaged, replace the system board.
  6. (Trained technician only) Remove the affected microprocessor and check the microprocessor socket pins for any damaged pins. If a damage is found, replace the system board.
  7. (Trained technician only) Replace the affected microprocessor.
  8. Manually re-enable all affected DIMMs if the server firmware version is older than UEFI v1.10. If the server firmware version is UEFI v1.10 or newer, disconnect and reconnect the server to the power source and restart the server.
  9. (Trained Service technician only) Replace the affected microprocessor.
- **806f010c-2016ffff : Uncorrectable error detected for [PhysicalMemoryElementName] on Subsystem [MemoryElementName]. (DIMM 22)**

This message is for the use case when an implementation has detected a Memory uncorrectable error.

May also be shown as 806f010c2016ffff or 0x806f010c2016ffff

**Severity**

Error

**Serviceable**

Yes

**Automatically notify support**

Yes

**Alert Category**

Critical - Memory

**SNMP Trap ID**

41

**CIM Information****Prefix:** PLAT ID: 0138

## User Response

Note: Each time you install or remove a DIMM, you must disconnect the server from the power source; then, wait 10 seconds before restarting the server.

1. Refer to TIP H212293 for minimum code level.
  2. Check the Lenovo support website for an applicable retain tip or firmware update that applies to this memory error.
  3. Swap the affected DIMMs (as indicated by the error LEDs on the system board or the event logs) to a different memory channel or microprocessor.
  4. If the problem follows the DIMM, replace the failing DIMM.
  5. (Trained technician only) If the problem occurs on the same DIMM connector, check the DIMM connector. If the connector contains any foreign material or is damaged, replace the system board.
  6. (Trained technician only) Remove the affected microprocessor and check the microprocessor socket pins for any damaged pins. If a damage is found, replace the system board.
  7. (Trained technician only) Replace the affected microprocessor.
  8. Manually re-enable all affected DIMMs if the server firmware version is older than UEFI v1.10. If the server firmware version is UEFI v1.10 or newer, disconnect and reconnect the server to the power source and restart the server.
  9. (Trained Service technician only) Replace the affected microprocessor.
- **806f010c-2017ffff : Uncorrectable error detected for [PhysicalMemoryElementName] on Subsystem [MemoryElementName]. (DIMM 23)**

This message is for the use case when an implementation has detected a Memory uncorrectable error.

May also be shown as 806f010c2017ffff or 0x806f010c2017ffff

## Severity

Error

## Serviceable

Yes

## Automatically notify support

Yes

## Alert Category

Critical - Memory

## SNMP Trap ID

41

## CIM Information

Prefix: PLAT ID: 0138

## User Response

Note: Each time you install or remove a DIMM, you must disconnect the server from the power source; then, wait 10 seconds before restarting the server.

1. Refer to TIP H212293 for minimum code level.
2. Check the Lenovo support website for an applicable retain tip or firmware update that applies to this memory error.
3. Swap the affected DIMMs (as indicated by the error LEDs on the system board or the event logs) to a different memory channel or microprocessor.
4. If the problem follows the DIMM, replace the failing DIMM.

5. (Trained technician only) If the problem occurs on the same DIMM connector, check the DIMM connector. If the connector contains any foreign material or is damaged, replace the system board.
6. (Trained technician only) Remove the affected microprocessor and check the microprocessor socket pins for any damaged pins. If a damage is found, replace the system board.
7. (Trained technician only) Replace the affected microprocessor.
8. Manually re-enable all affected DIMMs if the server firmware version is older than UEFI v1.10. If the server firmware version is UEFI v1.10 or newer, disconnect and reconnect the server to the power source and restart the server.
9. (Trained Service technician only) Replace the affected microprocessor.

- **806f010c-2018ffff : Uncorrectable error detected for [PhysicalMemoryElementName] on Subsystem [MemoryElementName]. (DIMM 24)**

This message is for the use case when an implementation has detected a Memory uncorrectable error.

May also be shown as 806f010c2018ffff or 0x806f010c2018ffff

**Severity**

Error

**Serviceable**

Yes

**Automatically notify support**

Yes

**Alert Category**

Critical - Memory

**SNMP Trap ID**

41

**CIM Information**

**Prefix:** PLAT ID: 0138

**User Response**

Note: Each time you install or remove a DIMM, you must disconnect the server from the power source; then, wait 10 seconds before restarting the server.

1. Refer to TIP H212293 for minimum code level.
2. Check the Lenovo support website for an applicable retain tip or firmware update that applies to this memory error.
3. Swap the affected DIMMs (as indicated by the error LEDs on the system board or the event logs) to a different memory channel or microprocessor.
4. If the problem follows the DIMM, replace the failing DIMM.
5. (Trained technician only) If the problem occurs on the same DIMM connector, check the DIMM connector. If the connector contains any foreign material or is damaged, replace the system board.
6. (Trained technician only) Remove the affected microprocessor and check the microprocessor socket pins for any damaged pins. If a damage is found, replace the system board.
7. (Trained technician only) Replace the affected microprocessor.
8. Manually re-enable all affected DIMMs if the server firmware version is older than UEFI v1.10. If the server firmware version is UEFI v1.10 or newer, disconnect and reconnect the server to the power source and restart the server.
9. (Trained Service technician only) Replace the affected microprocessor.

- **806f010c-2581ffff : Uncorrectable error detected for [PhysicalMemoryElementName] on Subsystem [MemoryElementName]. (All DIMMS)**

This message is for the use case when an implementation has detected a Memory uncorrectable error. May also be shown as 806f010c2581ffff or 0x806f010c2581ffff

**Severity**

Error

**Serviceable**

Yes

**Automatically notify support**

Yes

**Alert Category**

Critical - Memory

**SNMP Trap ID**

41

**CIM Information**

**Prefix:** PLAT ID: 0138

**User Response**

Note: Each time you install or remove a DIMM, you must disconnect the server from the power source; then, wait 10 seconds before restarting the server.

1. Refer to TIP H212293 for minimum code level.
2. Check the Lenovo support website for an applicable retain tip or firmware update that applies to this memory error.
3. Swap the affected DIMMs (as indicated by the error LEDs on the system board or the event logs) to a different memory channel or microprocessor.
4. If the problem follows the DIMM, replace the failing DIMM.
5. (Trained technician only) If the problem occurs on the same DIMM connector, check the DIMM connector. If the connector contains any foreign material or is damaged, replace the system board.
6. (Trained technician only) Remove the affected microprocessor and check the microprocessor socket pins for any damaged pins. If a damage is found, replace the system board.
7. (Trained technician only) Replace the affected microprocessor.
8. Manually re-enable all affected DIMMs if the server firmware version is older than UEFI v1.10. If the server firmware version is UEFI v1.10 or newer, disconnect and reconnect the server to the power source and restart the server.
9. (Trained Service technician only) Replace the affected microprocessor.

One of the DIMMs :

- **806f010d-0400ffff : The Drive [StorageVolumeElementName] has been disabled due to a detected fault. (Drive 0)**

This message is for the use case when an implementation has detected a Drive was Disabled due to fault. May also be shown as 806f010d0400ffff or 0x806f010d0400ffff

**Severity**

Error

**Serviceable**

Yes

**Automatically notify support**

Yes

**Alert Category**

Critical - Hard Disk drive

**SNMP Trap ID**

5

**CIM Information**

**Prefix:** PLAT ID: 0164

**User Response**

1. Run the hard disk drive diagnostic test on drive n.
  2. Reseat the following components: a. Hard disk drive (wait 1 minute or more before reinstalling the drive) b. Cable from the system board to the backplane
  3. Replace the following components one at a time, in the order shown, restarting the server each time: a. Hard disk drive b. Cable from the system board to the backplane c. Hard disk drive backplane (n = hard disk drive number)
- **806f010d-0401ffff : The Drive [StorageVolumeElementName] has been disabled due to a detected fault. (Drive 1)**

This message is for the use case when an implementation has detected a Drive was Disabled due to fault. May also be shown as 806f010d0401ffff or 0x806f010d0401ffff

**Severity**

Error

**Serviceable**

Yes

**Automatically notify support**

Yes

**Alert Category**

Critical - Hard Disk drive

**SNMP Trap ID**

5

**CIM Information**

**Prefix:** PLAT ID: 0164

**User Response**

1. Run the hard disk drive diagnostic test on drive n.
  2. Reseat the following components: a. Hard disk drive (wait 1 minute or more before reinstalling the drive) b. Cable from the system board to the backplane
  3. Replace the following components one at a time, in the order shown, restarting the server each time: a. Hard disk drive b. Cable from the system board to the backplane c. Hard disk drive backplane (n = hard disk drive number)
- **806f010d-0402ffff : The Drive [StorageVolumeElementName] has been disabled due to a detected fault. (Drive 2)**

This message is for the use case when an implementation has detected a Drive was Disabled due to fault. May also be shown as 806f010d0402ffff or 0x806f010d0402ffff

**Severity**

Error

**Serviceable**

Yes

**Automatically notify support**

Yes

**Alert Category**

Critical - Hard Disk drive

**SNMP Trap ID**

5

**CIM Information**

Prefix: PLAT ID: 0164

**User Response**

1. Run the hard disk drive diagnostic test on drive n.
  2. Reseat the following components: a. Hard disk drive (wait 1 minute or more before reinstalling the drive) b. Cable from the system board to the backplane
  3. Replace the following components one at a time, in the order shown, restarting the server each time: a. Hard disk drive b. Cable from the system board to the backplane c. Hard disk drive backplane (n = hard disk drive number)
- **806f010d-0403ffff : The Drive [StorageVolumeElementName] has been disabled due to a detected fault. (Drive 3)**

This message is for the use case when an implementation has detected a Drive was Disabled due to fault. May also be shown as 806f010d0403ffff or 0x806f010d0403ffff

**Severity**

Error

**Serviceable**

Yes

**Automatically notify support**

Yes

**Alert Category**

Critical - Hard Disk drive

**SNMP Trap ID**

5

**CIM Information**

Prefix: PLAT ID: 0164

**User Response**

1. Run the hard disk drive diagnostic test on drive n.
  2. Reseat the following components: a. Hard disk drive (wait 1 minute or more before reinstalling the drive) b. Cable from the system board to the backplane
  3. Replace the following components one at a time, in the order shown, restarting the server each time: a. Hard disk drive b. Cable from the system board to the backplane c. Hard disk drive backplane (n = hard disk drive number)
- **806f010d-0404ffff : The Drive [StorageVolumeElementName] has been disabled due to a detected fault. (Drive 4)**

This message is for the use case when an implementation has detected a Drive was Disabled due to fault. May also be shown as 806f010d0404ffff or 0x806f010d0404ffff

**Severity**

Error

**Serviceable**

Yes

**Automatically notify support**

Yes

**Alert Category**

Critical - Hard Disk drive

**SNMP Trap ID**

5

**CIM Information****Prefix: PLAT ID:** 0164**User Response**

1. Run the hard disk drive diagnostic test on drive n.
  2. Reseat the following components: a. Hard disk drive (wait 1 minute or more before reinstalling the drive) b. Cable from the system board to the backplane
  3. Replace the following components one at a time, in the order shown, restarting the server each time: a. Hard disk drive b. Cable from the system board to the backplane c. Hard disk drive backplane (n = hard disk drive number)
- **806f010d-0405ffff : The Drive [StorageVolumeElementName] has been disabled due to a detected fault. (Drive 5)**

This message is for the use case when an implementation has detected a Drive was Disabled due to fault. May also be shown as 806f010d0405ffff or 0x806f010d0405ffff

**Severity**

Error

**Serviceable**

Yes

**Automatically notify support**

Yes

**Alert Category**

Critical - Hard Disk drive

**SNMP Trap ID**

5

**CIM Information****Prefix: PLAT ID:** 0164**User Response**

1. Run the hard disk drive diagnostic test on drive n.
  2. Reseat the following components: a. Hard disk drive (wait 1 minute or more before reinstalling the drive) b. Cable from the system board to the backplane
  3. Replace the following components one at a time, in the order shown, restarting the server each time: a. Hard disk drive b. Cable from the system board to the backplane c. Hard disk drive backplane (n = hard disk drive number)
- **806f010d-0406ffff : The Drive [StorageVolumeElementName] has been disabled due to a detected fault. (Drive 6)**

This message is for the use case when an implementation has detected a Drive was Disabled due to fault.

May also be shown as 806f010d0406ffff or 0x806f010d0406ffff

**Severity**

Error

**Serviceable**

Yes

**Automatically notify support**

Yes

**Alert Category**

Critical - Hard Disk drive

**SNMP Trap ID**

5

**CIM Information**

**Prefix: PLAT ID:** 0164

**User Response**

1. Run the hard disk drive diagnostic test on drive n.
  2. Reseat the following components: a. Hard disk drive (wait 1 minute or more before reinstalling the drive) b. Cable from the system board to the backplane
  3. Replace the following components one at a time, in the order shown, restarting the server each time: a. Hard disk drive b. Cable from the system board to the backplane c. Hard disk drive backplane (n = hard disk drive number)
- **806f010d-0407ffff : The Drive [StorageVolumeElementName] has been disabled due to a detected fault. (Drive 7)**

This message is for the use case when an implementation has detected a Drive was Disabled due to fault.

May also be shown as 806f010d0407ffff or 0x806f010d0407ffff

**Severity**

Error

**Serviceable**

Yes

**Automatically notify support**

Yes

**Alert Category**

Critical - Hard Disk drive

**SNMP Trap ID**

5

**CIM Information**

**Prefix: PLAT ID:** 0164

**User Response**

1. Run the hard disk drive diagnostic test on drive n.
2. Reseat the following components: a. Hard disk drive (wait 1 minute or more before reinstalling the drive) b. Cable from the system board to the backplane
3. Replace the following components one at a time, in the order shown, restarting the server each time: a. Hard disk drive b. Cable from the system board to the backplane c. Hard disk drive backplane (n = hard disk drive number)



- **806f010d-0408ffff : The Drive [StorageVolumeElementName] has been disabled due to a detected fault. (Drive 8)**

This message is for the use case when an implementation has detected a Drive was Disabled due to fault.  
May also be shown as 806f010d0408ffff or 0x806f010d0408ffff

**Severity**

Error

**Serviceable**

Yes

**Automatically notify support**

Yes

**Alert Category**

Critical - Hard Disk drive

**SNMP Trap ID**

5

**CIM Information**

**Prefix: PLAT ID:** 0164

**User Response**

1. Run the hard disk drive diagnostic test on drive n.
  2. Reseat the following components: a. Hard disk drive (wait 1 minute or more before reinstalling the drive) b. Cable from the system board to the backplane
  3. Replace the following components one at a time, in the order shown, restarting the server each time: a. Hard disk drive b. Cable from the system board to the backplane c. Hard disk drive backplane (n = hard disk drive number)
- **806f010d-0409ffff : The Drive [StorageVolumeElementName] has been disabled due to a detected fault. (Drive 9)**

This message is for the use case when an implementation has detected a Drive was Disabled due to fault.  
May also be shown as 806f010d0409ffff or 0x806f010d0409ffff

**Severity**

Error

**Serviceable**

Yes

**Automatically notify support**

Yes

**Alert Category**

Critical - Hard Disk drive

**SNMP Trap ID**

5

**CIM Information**

**Prefix: PLAT ID:** 0164

**User Response**

1. Run the hard disk drive diagnostic test on drive n.
2. Reseat the following components: a. Hard disk drive (wait 1 minute or more before reinstalling the drive) b. Cable from the system board to the backplane

3. Replace the following components one at a time, in the order shown, restarting the server each time: a. Hard disk drive b. Cable from the system board to the backplane c. Hard disk drive backplane (n = hard disk drive number)

- **806f010d-040affff : The Drive [StorageVolumeElementName] has been disabled due to a detected fault. (Drive 10)**

This message is for the use case when an implementation has detected a Drive was Disabled due to fault. May also be shown as 806f010d040affff or 0x806f010d040affff

**Severity**

Error

**Serviceable**

Yes

**Automatically notify support**

Yes

**Alert Category**

Critical - Hard Disk drive

**SNMP Trap ID**

5

**CIM Information**

Prefix: PLAT ID: 0164

**User Response**

1. Run the hard disk drive diagnostic test on drive n.
  2. Reseat the following components: a. Hard disk drive (wait 1 minute or more before reinstalling the drive) b. Cable from the system board to the backplane
  3. Replace the following components one at a time, in the order shown, restarting the server each time: a. Hard disk drive b. Cable from the system board to the backplane c. Hard disk drive backplane (n = hard disk drive number)
- **806f010d-040bffff : The Drive [StorageVolumeElementName] has been disabled due to a detected fault. (Drive 11)**

This message is for the use case when an implementation has detected a Drive was Disabled due to fault. May also be shown as 806f010d040bffff or 0x806f010d040bffff

**Severity**

Error

**Serviceable**

Yes

**Automatically notify support**

Yes

**Alert Category**

Critical - Hard Disk drive

**SNMP Trap ID**

5

**CIM Information**

Prefix: PLAT ID: 0164

**User Response**

1. Run the hard disk drive diagnostic test on drive n.

2. Reseat the following components: a. Hard disk drive (wait 1 minute or more before reinstalling the drive) b. Cable from the system board to the backplane
  3. Replace the following components one at a time, in the order shown, restarting the server each time: a. Hard disk drive b. Cable from the system board to the backplane c. Hard disk drive backplane (n = hard disk drive number)
- **806f010d-040cffff : The Drive [StorageVolumeElementName] has been disabled due to a detected fault. (Drive 12)**

This message is for the use case when an implementation has detected a Drive was Disabled due to fault. May also be shown as 806f010d040cffff or 0x806f010d040cffff

**Severity**

Error

**Serviceable**

Yes

**Automatically notify support**

Yes

**Alert Category**

Critical - Hard Disk drive

**SNMP Trap ID**

5

**CIM Information**

**Prefix:** PLAT ID: 0164

**User Response**

1. Run the hard disk drive diagnostic test on drive n.
  2. Reseat the following components: a. Hard disk drive (wait 1 minute or more before reinstalling the drive) b. Cable from the system board to the backplane
  3. Replace the following components one at a time, in the order shown, restarting the server each time: a. Hard disk drive b. Cable from the system board to the backplane c. Hard disk drive backplane (n = hard disk drive number)
- **806f010d-040dffff : The Drive [StorageVolumeElementName] has been disabled due to a detected fault. (Drive 13)**

This message is for the use case when an implementation has detected a Drive was Disabled due to fault. May also be shown as 806f010d040dffff or 0x806f010d040dffff

**Severity**

Error

**Serviceable**

Yes

**Automatically notify support**

Yes

**Alert Category**

Critical - Hard Disk drive

**SNMP Trap ID**

5

**CIM Information**

**Prefix:** PLAT ID: 0164

### User Response

1. Run the hard disk drive diagnostic test on drive n.
  2. Reseat the following components: a. Hard disk drive (wait 1 minute or more before reinstalling the drive) b. Cable from the system board to the backplane
  3. Replace the following components one at a time, in the order shown, restarting the server each time: a. Hard disk drive b. Cable from the system board to the backplane c. Hard disk drive backplane (n = hard disk drive number)
- **806f010d-040effff : The Drive [StorageVolumeElementName] has been disabled due to a detected fault. (Drive 14)**

This message is for the use case when an implementation has detected a Drive was Disabled due to fault. May also be shown as 806f010d040effff or 0x806f010d040effff

### Severity

Error

### Serviceable

Yes

### Automatically notify support

Yes

### Alert Category

Critical - Hard Disk drive

### SNMP Trap ID

5

### CIM Information

Prefix: PLAT ID: 0164

### User Response

1. Run the hard disk drive diagnostic test on drive n.
  2. Reseat the following components: a. Hard disk drive (wait 1 minute or more before reinstalling the drive) b. Cable from the system board to the backplane
  3. Replace the following components one at a time, in the order shown, restarting the server each time: a. Hard disk drive b. Cable from the system board to the backplane c. Hard disk drive backplane (n = hard disk drive number)
- **806f010d-040fffff : The Drive [StorageVolumeElementName] has been disabled due to a detected fault. (Drive 15)**

This message is for the use case when an implementation has detected a Drive was Disabled due to fault. May also be shown as 806f010d040fffff or 0x806f010d040fffff

### Severity

Error

### Serviceable

Yes

### Automatically notify support

Yes

### Alert Category

Critical - Hard Disk drive

### SNMP Trap ID

5

**CIM Information**

Prefix: PLAT ID: 0164

**User Response**

1. Run the hard disk drive diagnostic test on drive n.
  2. Reseat the following components: a. Hard disk drive (wait 1 minute or more before reinstalling the drive) b. Cable from the system board to the backplane
  3. Replace the following components one at a time, in the order shown, restarting the server each time: a. Hard disk drive b. Cable from the system board to the backplane c. Hard disk drive backplane (n = hard disk drive number)
- **806f010d-0410ffff : The Drive [StorageVolumeElementName] has been disabled due to a detected fault. (Drive 16)**

This message is for the use case when an implementation has detected a Drive was Disabled due to fault. May also be shown as 806f010d0410ffff or 0x806f010d0410ffff

**Severity**

Error

**Serviceable**

Yes

**Automatically notify support**

Yes

**Alert Category**

Critical - Hard Disk drive

**SNMP Trap ID**

5

**CIM Information**

Prefix: PLAT ID: 0164

**User Response**

1. Run the hard disk drive diagnostic test on drive n.
  2. Reseat the following components: a. Hard disk drive (wait 1 minute or more before reinstalling the drive) b. Cable from the system board to the backplane
  3. Replace the following components one at a time, in the order shown, restarting the server each time: a. Hard disk drive b. Cable from the system board to the backplane c. Hard disk drive backplane (n = hard disk drive number)
- **806f010d-0411ffff : The Drive [StorageVolumeElementName] has been disabled due to a detected fault. (Drive 17)**

This message is for the use case when an implementation has detected a Drive was Disabled due to fault. May also be shown as 806f010d0411ffff or 0x806f010d0411ffff

**Severity**

Error

**Serviceable**

Yes

**Automatically notify support**

Yes

**Alert Category**

Critical - Hard Disk drive

**SNMP Trap ID**

5

**CIM Information**

Prefix: PLAT ID: 0164

**User Response**

1. Run the hard disk drive diagnostic test on drive n.
  2. Reseat the following components: a. Hard disk drive (wait 1 minute or more before reinstalling the drive) b. Cable from the system board to the backplane
  3. Replace the following components one at a time, in the order shown, restarting the server each time: a. Hard disk drive b. Cable from the system board to the backplane c. Hard disk drive backplane (n = hard disk drive number)
- **806f010d-0412ffff : The Drive [StorageVolumeElementName] has been disabled due to a detected fault. (Drive 18)**

This message is for the use case when an implementation has detected a Drive was Disabled due to fault. May also be shown as 806f010d0412ffff or 0x806f010d0412ffff

**Severity**

Error

**Serviceable**

Yes

**Automatically notify support**

Yes

**Alert Category**

Critical - Hard Disk drive

**SNMP Trap ID**

5

**CIM Information**

Prefix: PLAT ID: 0164

**User Response**

1. Run the hard disk drive diagnostic test on drive n.
  2. Reseat the following components: a. Hard disk drive (wait 1 minute or more before reinstalling the drive) b. Cable from the system board to the backplane
  3. Replace the following components one at a time, in the order shown, restarting the server each time: a. Hard disk drive b. Cable from the system board to the backplane c. Hard disk drive backplane (n = hard disk drive number)
- **806f010d-0413ffff : The Drive [StorageVolumeElementName] has been disabled due to a detected fault. (Drive 19)**

This message is for the use case when an implementation has detected a Drive was Disabled due to fault. May also be shown as 806f010d0413ffff or 0x806f010d0413ffff

**Severity**

Error

**Serviceable**

Yes

**Automatically notify support**

Yes

**Alert Category**

Critical - Hard Disk drive

**SNMP Trap ID**

5

**CIM Information**

**Prefix:** PLAT ID: 0164

**User Response**

1. Run the hard disk drive diagnostic test on drive n.
  2. Reseat the following components: a. Hard disk drive (wait 1 minute or more before reinstalling the drive) b. Cable from the system board to the backplane
  3. Replace the following components one at a time, in the order shown, restarting the server each time: a. Hard disk drive b. Cable from the system board to the backplane c. Hard disk drive backplane (n = hard disk drive number)
- **806f010d-0414ffff : The Drive [StorageVolumeElementName] has been disabled due to a detected fault. (Drive 20)**

This message is for the use case when an implementation has detected a Drive was Disabled due to fault. May also be shown as 806f010d0414ffff or 0x806f010d0414ffff

**Severity**

Error

**Serviceable**

Yes

**Automatically notify support**

Yes

**Alert Category**

Critical - Hard Disk drive

**SNMP Trap ID**

5

**CIM Information**

**Prefix:** PLAT ID: 0164

**User Response**

1. Run the hard disk drive diagnostic test on drive n.
  2. Reseat the following components: a. Hard disk drive (wait 1 minute or more before reinstalling the drive) b. Cable from the system board to the backplane
  3. Replace the following components one at a time, in the order shown, restarting the server each time: a. Hard disk drive b. Cable from the system board to the backplane c. Hard disk drive backplane (n = hard disk drive number)
- **806f010d-0415ffff : The Drive [StorageVolumeElementName] has been disabled due to a detected fault. (Drive 21)**

This message is for the use case when an implementation has detected a Drive was Disabled due to fault. May also be shown as 806f010d0415ffff or 0x806f010d0415ffff

**Severity**

Error

**Serviceable**

Yes

**Automatically notify support**

Yes

**Alert Category**

Critical - Hard Disk drive

**SNMP Trap ID**

5

**CIM Information**

Prefix: PLAT ID: 0164

**User Response**

1. Run the hard disk drive diagnostic test on drive n.
  2. Reseat the following components: a. Hard disk drive (wait 1 minute or more before reinstalling the drive) b. Cable from the system board to the backplane
  3. Replace the following components one at a time, in the order shown, restarting the server each time: a. Hard disk drive b. Cable from the system board to the backplane c. Hard disk drive backplane (n = hard disk drive number)
- **806f010d-0416ffff : The Drive [StorageVolumeElementName] has been disabled due to a detected fault. (Drive 22)**

This message is for the use case when an implementation has detected a Drive was Disabled due to fault.

May also be shown as 806f010d0416ffff or 0x806f010d0416ffff

**Severity**

Error

**Serviceable**

Yes

**Automatically notify support**

Yes

**Alert Category**

Critical - Hard Disk drive

**SNMP Trap ID**

5

**CIM Information**

Prefix: PLAT ID: 0164

**User Response**

1. Run the hard disk drive diagnostic test on drive n.
  2. Reseat the following components: a. Hard disk drive (wait 1 minute or more before reinstalling the drive) b. Cable from the system board to the backplane
  3. Replace the following components one at a time, in the order shown, restarting the server each time: a. Hard disk drive b. Cable from the system board to the backplane c. Hard disk drive backplane (n = hard disk drive number)
- **806f010d-0417ffff : The Drive [StorageVolumeElementName] has been disabled due to a detected fault. (Drive 23)**

This message is for the use case when an implementation has detected a Drive was Disabled due to fault.

May also be shown as 806f010d0417ffff or 0x806f010d0417ffff

**Severity**

Error



**Serviceable**

Yes

**Automatically notify support**

Yes

**Alert Category**

Critical - Hard Disk drive

**SNMP Trap ID**

5

**CIM Information**

**Prefix:** PLAT ID: 0164

**User Response**

1. Run the hard disk drive diagnostic test on drive n.
  2. Reseat the following components: a. Hard disk drive (wait 1 minute or more before reinstalling the drive) b. Cable from the system board to the backplane
  3. Replace the following components one at a time, in the order shown, restarting the server each time: a. Hard disk drive b. Cable from the system board to the backplane c. Hard disk drive backplane (n = hard disk drive number)
- **806f010d-0418ffff : The Drive [StorageVolumeElementName] has been disabled due to a detected fault. (Drive 24)**

This message is for the use case when an implementation has detected a Drive was Disabled due to fault. May also be shown as 806f010d0418ffff or 0x806f010d0418ffff

**Severity**

Error

**Serviceable**

Yes

**Automatically notify support**

Yes

**Alert Category**

Critical - Hard Disk drive

**SNMP Trap ID**

5

**CIM Information**

**Prefix:** PLAT ID: 0164

**User Response**

1. Run the hard disk drive diagnostic test on drive n.
  2. Reseat the following components: a. Hard disk drive (wait 1 minute or more before reinstalling the drive) b. Cable from the system board to the backplane
  3. Replace the following components one at a time, in the order shown, restarting the server each time: a. Hard disk drive b. Cable from the system board to the backplane c. Hard disk drive backplane (n = hard disk drive number)
- **806f010d-0419ffff : The Drive [StorageVolumeElementName] has been disabled due to a detected fault. (Drive 25)**

This message is for the use case when an implementation has detected a Drive was Disabled due to fault. May also be shown as 806f010d0419ffff or 0x806f010d0419ffff

**Severity**

Error

**Serviceable**

Yes

**Automatically notify support**

Yes

**Alert Category**

Critical - Hard Disk drive

**SNMP Trap ID**

5

**CIM Information**

Prefix: PLAT ID: 0164

**User Response**

1. Run the hard disk drive diagnostic test on drive n.
  2. Reseat the following components: a. Hard disk drive (wait 1 minute or more before reinstalling the drive) b. Cable from the system board to the backplane
  3. Replace the following components one at a time, in the order shown, restarting the server each time: a. Hard disk drive b. Cable from the system board to the backplane c. Hard disk drive backplane (n = hard disk drive number)
- **806f010d-041affff : The Drive [StorageVolumeElementName] has been disabled due to a detected fault. (Drive 26)**

This message is for the use case when an implementation has detected a Drive was Disabled due to fault. May also be shown as 806f010d041affff or 0x806f010d041affff

**Severity**

Error

**Serviceable**

Yes

**Automatically notify support**

Yes

**Alert Category**

Critical - Hard Disk drive

**SNMP Trap ID**

5

**CIM Information**

Prefix: PLAT ID: 0164

**User Response**

1. Run the hard disk drive diagnostic test on drive n.
  2. Reseat the following components: a. Hard disk drive (wait 1 minute or more before reinstalling the drive) b. Cable from the system board to the backplane
  3. Replace the following components one at a time, in the order shown, restarting the server each time: a. Hard disk drive b. Cable from the system board to the backplane c. Hard disk drive backplane (n = hard disk drive number)
- **806f010d-041bffff : The Drive [StorageVolumeElementName] has been disabled due to a detected fault. (Drive 27)**

This message is for the use case when an implementation has detected a Drive was Disabled due to fault.

May also be shown as 806f010d041bffff or 0x806f010d041bffff

**Severity**

Error

**Serviceable**

Yes

**Automatically notify support**

Yes

**Alert Category**

Critical - Hard Disk drive

**SNMP Trap ID**

5

**CIM Information**

**Prefix: PLAT ID:** 0164

**User Response**

1. Run the hard disk drive diagnostic test on drive n.
  2. Reseat the following components: a. Hard disk drive (wait 1 minute or more before reinstalling the drive) b. Cable from the system board to the backplane
  3. Replace the following components one at a time, in the order shown, restarting the server each time: a. Hard disk drive b. Cable from the system board to the backplane c. Hard disk drive backplane (n = hard disk drive number)
- **806f010d-041cffff : The Drive [StorageVolumeElementName] has been disabled due to a detected fault. (Drive 28)**

This message is for the use case when an implementation has detected a Drive was Disabled due to fault.

May also be shown as 806f010d041cffff or 0x806f010d041cffff

**Severity**

Error

**Serviceable**

Yes

**Automatically notify support**

Yes

**Alert Category**

Critical - Hard Disk drive

**SNMP Trap ID**

5

**CIM Information**

**Prefix: PLAT ID:** 0164

**User Response**

1. Run the hard disk drive diagnostic test on drive n.
2. Reseat the following components: a. Hard disk drive (wait 1 minute or more before reinstalling the drive) b. Cable from the system board to the backplane
3. Replace the following components one at a time, in the order shown, restarting the server each time: a. Hard disk drive b. Cable from the system board to the backplane c. Hard disk drive backplane (n = hard disk drive number)

- **806f010d-041dffff : The Drive [StorageVolumeElementName] has been disabled due to a detected fault. (Drive 29)**

This message is for the use case when an implementation has detected a Drive was Disabled due to fault. May also be shown as 806f010d041dffff or 0x806f010d041dffff

**Severity**

Error

**Serviceable**

Yes

**Automatically notify support**

Yes

**Alert Category**

Critical - Hard Disk drive

**SNMP Trap ID**

5

**CIM Information**

Prefix: PLAT ID: 0164

**User Response**

1. Run the hard disk drive diagnostic test on drive n.
2. Reseat the following components: a. Hard disk drive (wait 1 minute or more before reinstalling the drive) b. Cable from the system board to the backplane
3. Replace the following components one at a time, in the order shown, restarting the server each time: a. Hard disk drive b. Cable from the system board to the backplane c. Hard disk drive backplane (n = hard disk drive number)

- **806f010d-041effff : The Drive [StorageVolumeElementName] has been disabled due to a detected fault. (Drive 30)**

This message is for the use case when an implementation has detected a Drive was Disabled due to fault. May also be shown as 806f010d041effff or 0x806f010d041effff

**Severity**

Error

**Serviceable**

Yes

**Automatically notify support**

Yes

**Alert Category**

Critical - Hard Disk drive

**SNMP Trap ID**

5

**CIM Information**

Prefix: PLAT ID: 0164

**User Response**

1. Run the hard disk drive diagnostic test on drive n.
2. Reseat the following components: a. Hard disk drive (wait 1 minute or more before reinstalling the drive) b. Cable from the system board to the backplane

3. Replace the following components one at a time, in the order shown, restarting the server each time: a. Hard disk drive b. Cable from the system board to the backplane c. Hard disk drive backplane (n = hard disk drive number)

- **806f010d-041ffff : The Drive [StorageVolumeElementName] has been disabled due to a detected fault. (Drive 31)**

This message is for the use case when an implementation has detected a Drive was Disabled due to fault. May also be shown as 806f010d041ffff or 0x806f010d041ffff

**Severity**

Error

**Serviceable**

Yes

**Automatically notify support**

Yes

**Alert Category**

Critical - Hard Disk drive

**SNMP Trap ID**

5

**CIM Information**

**Prefix:** PLAT ID: 0164

**User Response**

1. Run the hard disk drive diagnostic test on drive n.
2. Reseat the following components: a. Hard disk drive (wait 1 minute or more before reinstalling the drive) b. Cable from the system board to the backplane
3. Replace the following components one at a time, in the order shown, restarting the server each time: a. Hard disk drive b. Cable from the system board to the backplane c. Hard disk drive backplane (n = hard disk drive number)

- **806f010d-0420fff : The Drive [StorageVolumeElementName] has been disabled due to a detected fault. (Ext Drive)**

This message is for the use case when an implementation has detected a Drive was Disabled due to fault. May also be shown as 806f010d0420fff or 0x806f010d0420fff

**Severity**

Error

**Serviceable**

Yes

**Automatically notify support**

Yes

**Alert Category**

Critical - Hard Disk drive

**SNMP Trap ID**

5

**CIM Information**

**Prefix:** PLAT ID: 0164

**User Response**

1. Run the hard disk drive diagnostic test on drive n.

2. Reseat the following components: a. Hard disk drive (wait 1 minute or more before reinstalling the drive) b. Cable from the system board to the backplane
  3. Replace the following components one at a time, in the order shown, restarting the server each time: a. Hard disk drive b. Cable from the system board to the backplane c. Hard disk drive backplane (n = hard disk drive number)
- **806f010f-2201ffff : The System [ComputerSystemElementName] encountered a firmware hang. (Firmware Error)**

This message is for the use case when an implementation has detected a System Firmware Hang.

May also be shown as 806f010f2201ffff or 0x806f010f2201ffff

**Severity**

Error

**Serviceable**

Yes

**Automatically notify support**

No

**Alert Category**

System - Boot failure

**SNMP Trap ID**

25

**CIM Information**

**Prefix: PLAT ID:** 0186

**User Response**

1. Make sure the server meets the minimum configuration to start (see Power-supply LEDs).
  2. Update the server firmware on the primary page. Important: Some cluster solutions require specific code levels or coordinated code updates. If the device is part of a cluster solution, verify that the latest level of code is supported for the cluster solution before you update the code.
  3. (Trained technician only) Replace the system board.
- **806f0113-0301ffff : A bus timeout has occurred on system [ComputerSystemElementName]. (CPU 1 PECI)**

This message is for the use case when an implementation has detected a Bus Timeout.

May also be shown as 806f01130301ffff or 0x806f01130301ffff

**Severity**

Error

**Serviceable**

Yes

**Automatically notify support**

No

**Alert Category**

Critical - Other

**SNMP Trap ID**

50

**CIM Information**

**Prefix: PLAT ID:** 0224

**User Response**

1. Reseat the microprocessor, and then restart the server.
  2. Replace microprocessor n. (n = microprocessor number)
- **806f0113-0302ffff : A bus timeout has occurred on system [ComputerSystemElementName]. (CPU 2 PECI)**

This message is for the use case when an implementation has detected a Bus Timeout.

May also be shown as 806f01130302ffff or 0x806f01130302ffff

**Severity**

Error

**Serviceable**

Yes

**Automatically notify support**

No

**Alert Category**

Critical - Other

**SNMP Trap ID**

50

**CIM Information**

**Prefix:** PLAT ID: 0224

**User Response**

1. Reseat the microprocessor, and then restart the server.
  2. Replace microprocessor n. (n = microprocessor number)
- **806f011b-0701ffff : The connector [PhysicalConnectorElementName] has encountered a configuration error. (Front USB)**

This message is for the use case when an implementation has detected an Interconnect Configuration Error.

May also be shown as 806f011b0701ffff or 0x806f011b0701ffff

**Severity**

Error

**Serviceable**

Yes

**Automatically notify support**

Yes

**Alert Category**

Critical - Other

**SNMP Trap ID**

50

**CIM Information**

**Prefix:** PLAT ID: 0266

**User Response**

If the specified sensor is front USB connector, reset the front USB cable on the system board. If the specified sensor is front video connector, reset the front video cable in the system board. If the specified sensor is PwrPaddle cable, complete the following steps until problem is solved:

1. Reseat the power paddle cable on the system board.
2. Replace the power paddle cable.

3. (Trained technician only) Replace the supercap n. (n = supercap number)
4. (Trained technician only) Replace the system board.

Front Video :

- **806f011b-0c01ffff : The connector [PhysicalConnectorElementName] has encountered a configuration error. (FP LCD Cable)**

This message is for the use case when an implementation has detected an Interconnect Configuration Error.

May also be shown as 806f011b0c01ffff or 0x806f011b0c01ffff

**Severity**

Error

**Serviceable**

Yes

**Automatically notify support**

Yes

**Alert Category**

Critical - Other

**SNMP Trap ID**

50

**CIM Information**

**Prefix: PLAT ID: 0266**

**User Response**

1. Check system event log is showing LCD cable sensor has deasserted.
  2. Reseat LCD cable on the system board.
  3. Reset LCD cable on LCD panel.
  4. Replace LCD cable.
- **806f011b-2586ffff : The connector [PhysicalConnectorElementName] has encountered a configuration error. (nvDIMM Cable)**
- This message is for the use case when an implementation has detected an Interconnect Configuration Error.
- May also be shown as 806f011b2586ffff or 0x806f011b2586ffff

**Severity**

Error

**Serviceable**

Yes

**Automatically notify support**

Yes

**Alert Category**

Critical - Other

**SNMP Trap ID**

50

**CIM Information**

**Prefix: PLAT ID: 0266**

**User Response**



If the specified sensor is front USB connector, reset the front USB cable on the system board. If the specified sensor is front video connector, reset the front video cable in the system board. If the specified sensor is PwrPaddle cable, complete the following steps until problem is solved:

1. Reseat the power paddle cable on the system board.
  2. Replace the power paddle cable.
  3. (Trained technician only) Replace the supercap n. (n = supercap number)
  4. (Trained technician only) Replace the system board.
- **806f0123-2101ffff : Reboot of system [ComputerSystemElementName] initiated by [WatchdogElementName]. (IPMI Watchdog)**

This message is for the use case when an implementation has detected a Reboot by a Watchdog occurred.

May also be shown as 806f01232101ffff or 0x806f01232101ffff

**Severity**

Info

**Serviceable**

No

**Automatically notify support**

No

**Alert Category**

System - Other

**SNMP Trap ID**

**CIM Information**

**Prefix:** PLAT ID: 0370

**User Response**

No action; information only.

- **806f0125-0c01ffff : [ManagedElementName] detected as absent. (Front Panel)**

This message is for the use case when an implementation has detected a Managed Element is Absent.

May also be shown as 806f01250c01ffff or 0x806f01250c01ffff

**Severity**

Info

**Serviceable**

No

**Automatically notify support**

No

**Alert Category**

System - Other

**SNMP Trap ID**

**CIM Information**

**Prefix:** PLAT ID: 0392

**User Response**

If there is no GPU/storage tray installed in the system, then the log event is a normal condition. If there is a GPU/storage tray installed in the system, then check the following two portions:

1. PDB (Power Distribution Board) cable is correctly connected from riser card to PDB.
2. Replace another PDB cable.

- **806f0125-1001ffff : [ManagedElementName] detected as absent. (PCI Riser 1)**

This message is for the use case when an implementation has detected a Managed Element is Absent.

May also be shown as 806f01251001ffff or 0x806f01251001ffff

**Severity**

Info

**Serviceable**

No

**Automatically notify support**

No

**Alert Category**

System - Other

**SNMP Trap ID**

**CIM Information**

Prefix: PLAT ID: 0392

**User Response**

If there is no GPU/storage tray installed in the system, then the log event is a normal condition. If there is a GPU/storage tray installed in the system, then check the following two portions:

1. PDB (Power Distribution Board) cable is correctly connected from riser card to PDB.
2. Replace another PDB cable.

- **806f0125-1002ffff : [ManagedElementName] detected as absent. (PCI Riser 2)**

This message is for the use case when an implementation has detected a Managed Element is Absent.

May also be shown as 806f01251002ffff or 0x806f01251002ffff

**Severity**

Info

**Serviceable**

No

**Automatically notify support**

No

**Alert Category**

System - Other

**SNMP Trap ID**

**CIM Information**

Prefix: PLAT ID: 0392

**User Response**

If there is no GPU/storage tray installed in the system, then the log event is a normal condition. If there is a GPU/storage tray installed in the system, then check the following two portions:

1. PDB (Power Distribution Board) cable is correctly connected from riser card to PDB.
2. Replace another PDB cable.

- **806f0125-100bffff : [ManagedElementName] detected as absent. (PDB Card)**

This message is for the use case when an implementation has detected a Managed Element is Absent.  
May also be shown as 806f0125100bffff or 0x806f0125100bffff

**Severity**

Info

**Serviceable**

No

**Automatically notify support**

No

**Alert Category**

System - Other

**SNMP Trap ID**

**CIM Information**

Prefix: PLAT ID: 0392

**User Response**

If there is no GPU/storage tray installed in the system, then the log event is a normal condition. If there is a GPU/storage tray installed in the system, then check the following two portions:

1. PDB (Power Distribution Board) cable is correctly connected from riser card to PDB.
2. Replace another PDB cable.

- **806f0125-2c01ffff : [ManagedElementName] detected as absent. (ML2 Card)**

This message is for the use case when an implementation has detected a Managed Element is Absent.  
May also be shown as 806f01252c01ffff or 0x806f01252c01ffff

**Severity**

Info

**Serviceable**

No

**Automatically notify support**

No

**Alert Category**

System - Other

**SNMP Trap ID**

**CIM Information**

Prefix: PLAT ID: 0392

**User Response**

Ensure PCI riser 1 and ML2 card are installed correctly.

- **806f0207-0301ffff : [ProcessorElementName] has Failed with FRB1/BIST condition. (CPU 1)**

This message is for the use case when an implementation has detected a Processor Failed - FRB1/BIST condition.

May also be shown as 806f02070301ffff or 0x806f02070301ffff

**Severity**

Error

**Serviceable**

Yes

**Automatically notify support**

Yes

**Alert Category**

Critical - CPU

**SNMP Trap ID**

40

**CIM Information**

**Prefix:** PLAT ID: 0044

**User Response**

1. Make sure that the latest levels of firmware and device drivers are installed for all adapters and standard devices, such as Ethernet, SCSI, and SAS. Important: Some cluster solutions require specific code levels or coordinated code updates. If the device is part of a cluster solution, verify that the latest level of code is supported for the cluster solution before you update the code.
  2. Update the firmware (UEFI and IMM) to the latest level (Updating the firmware).
  3. Run the DSA program.
  4. Reseat the adapter.
  5. Replace the adapter.
  6. (Trained technician only) Replace microprocessor n.
  7. (Trained technician only) Replace the system board. (n = microprocessor number)
- **806f0207-0302ffff : [ProcessorElementName] has Failed with FRB1/BIST condition. (CPU 2)**

This message is for the use case when an implementation has detected a Processor Failed - FRB1/BIST condition.

May also be shown as 806f02070302ffff or 0x806f02070302ffff

**Severity**

Error

**Serviceable**

Yes

**Automatically notify support**

Yes

**Alert Category**

Critical - CPU

**SNMP Trap ID**

40

**CIM Information**

**Prefix:** PLAT ID: 0044

**User Response**

1. Make sure that the latest levels of firmware and device drivers are installed for all adapters and standard devices, such as Ethernet, SCSI, and SAS. Important: Some cluster solutions require specific code levels or coordinated code updates. If the device is part of a cluster solution, verify that the latest level of code is supported for the cluster solution before you update the code.
2. Update the firmware (UEFI and IMM) to the latest level (Updating the firmware).
3. Run the DSA program.
4. Reseat the adapter.

5. Replace the adapter.
  6. (Trained technician only) Replace microprocessor n.
  7. (Trained technician only) Replace the system board. (n = microprocessor number)
- **806f0207-2584ffff : [ProcessorElementName] has Failed with FRB1/BIST condition. (All CPUs)**

This message is for the use case when an implementation has detected a Processor Failed - FRB1/BIST condition.

May also be shown as 806f02072584ffff or 0x806f02072584ffff

**Severity**

Error

**Serviceable**

Yes

**Automatically notify support**

Yes

**Alert Category**

Critical - CPU

**SNMP Trap ID**

40

**CIM Information**

Prefix: PLAT ID: 0044

**User Response**

1. Make sure that the latest levels of firmware and device drivers are installed for all adapters and standard devices, such as Ethernet, SCSI, and SAS. Important: Some cluster solutions require specific code levels or coordinated code updates. If the device is part of a cluster solution, verify that the latest level of code is supported for the cluster solution before you update the code.
2. Update the firmware (UEFI and IMM) to the latest level (Updating the firmware).
3. Run the DSA program.
4. Reseat the adapter.
5. Replace the adapter.
6. (Trained technician only) Replace microprocessor n.
7. (Trained technician only) Replace the system board. (n = microprocessor number)

One of the CPUs :

- **806f020d-0400ffff : Failure Predicted on drive [StorageVolumeElementName] for array [ComputerSystemElementName]. (Drive 0)**

This message is for the use case when an implementation has detected an Array Failure is Predicted.

May also be shown as 806f020d0400ffff or 0x806f020d0400ffff

**Severity**

Warning

**Serviceable**

Yes

**Automatically notify support**

Yes

**Alert Category**

System - Predicted Failure

**SNMP Trap ID**

27

**CIM Information****Prefix:** PLAT ID: 0168**User Response**

1. Run the hard disk drive diagnostic test on drive n.
  2. Reseat the following components: a. Hard disk drive (wait 1 minute or more before reinstalling the drive) b. Cable from the system board to the backplane
  3. Replace the following components one at a time, in the order shown, restarting the server each time: a. Hard disk drive b. Cable from the system board to the backplane c. Hard disk drive backplane (n = hard disk drive number)
- **806f020d-0401ffff : Failure Predicted on drive [StorageVolumeElementName] for array [ComputerSystemElementName]. (Drive 1)**

This message is for the use case when an implementation has detected an Array Failure is Predicted.

May also be shown as 806f020d0401ffff or 0x806f020d0401ffff

**Severity**

Warning

**Serviceable**

Yes

**Automatically notify support**

Yes

**Alert Category**

System - Predicted Failure

**SNMP Trap ID**

27

**CIM Information****Prefix:** PLAT ID: 0168**User Response**

1. Run the hard disk drive diagnostic test on drive n.
  2. Reseat the following components: a. Hard disk drive (wait 1 minute or more before reinstalling the drive) b. Cable from the system board to the backplane
  3. Replace the following components one at a time, in the order shown, restarting the server each time: a. Hard disk drive b. Cable from the system board to the backplane c. Hard disk drive backplane (n = hard disk drive number)
- **806f020d-0402ffff : Failure Predicted on drive [StorageVolumeElementName] for array [ComputerSystemElementName]. (Drive 2)**

This message is for the use case when an implementation has detected an Array Failure is Predicted.

May also be shown as 806f020d0402ffff or 0x806f020d0402ffff

**Severity**

Warning

**Serviceable**

Yes

**Automatically notify support**

Yes

**Alert Category**

System - Predicted Failure

**SNMP Trap ID**

27

**CIM Information**

**Prefix:** PLAT ID: 0168

**User Response**

1. Run the hard disk drive diagnostic test on drive n.
  2. Reseat the following components: a. Hard disk drive (wait 1 minute or more before reinstalling the drive) b. Cable from the system board to the backplane
  3. Replace the following components one at a time, in the order shown, restarting the server each time: a. Hard disk drive b. Cable from the system board to the backplane c. Hard disk drive backplane (n = hard disk drive number)
- **806f020d-0403ffff : Failure Predicted on drive [StorageVolumeElementName] for array [ComputerSystemElementName]. (Drive 3)**

This message is for the use case when an implementation has detected an Array Failure is Predicted.

May also be shown as 806f020d0403ffff or 0x806f020d0403ffff

**Severity**

Warning

**Serviceable**

Yes

**Automatically notify support**

Yes

**Alert Category**

System - Predicted Failure

**SNMP Trap ID**

27

**CIM Information**

**Prefix:** PLAT ID: 0168

**User Response**

1. Run the hard disk drive diagnostic test on drive n.
  2. Reseat the following components: a. Hard disk drive (wait 1 minute or more before reinstalling the drive) b. Cable from the system board to the backplane
  3. Replace the following components one at a time, in the order shown, restarting the server each time: a. Hard disk drive b. Cable from the system board to the backplane c. Hard disk drive backplane (n = hard disk drive number)
- **806f020d-0404ffff : Failure Predicted on drive [StorageVolumeElementName] for array [ComputerSystemElementName]. (Drive 4)**

This message is for the use case when an implementation has detected an Array Failure is Predicted.

May also be shown as 806f020d0404ffff or 0x806f020d0404ffff

**Severity**

Warning

**Serviceable**

Yes

**Automatically notify support**

Yes

**Alert Category**

System - Predicted Failure

**SNMP Trap ID**

27

**CIM Information**

**Prefix:** PLAT ID: 0168

**User Response**

1. Run the hard disk drive diagnostic test on drive n.
  2. Reseat the following components: a. Hard disk drive (wait 1 minute or more before reinstalling the drive) b. Cable from the system board to the backplane
  3. Replace the following components one at a time, in the order shown, restarting the server each time: a. Hard disk drive b. Cable from the system board to the backplane c. Hard disk drive backplane (n = hard disk drive number)
- **806f020d-0405ffff : Failure Predicted on drive [StorageVolumeElementName] for array [ComputerSystemElementName]. (Drive 5)**

This message is for the use case when an implementation has detected an Array Failure is Predicted.

May also be shown as 806f020d0405ffff or 0x806f020d0405ffff

**Severity**

Warning

**Serviceable**

Yes

**Automatically notify support**

Yes

**Alert Category**

System - Predicted Failure

**SNMP Trap ID**

27

**CIM Information**

**Prefix:** PLAT ID: 0168

**User Response**

1. Run the hard disk drive diagnostic test on drive n.
  2. Reseat the following components: a. Hard disk drive (wait 1 minute or more before reinstalling the drive) b. Cable from the system board to the backplane
  3. Replace the following components one at a time, in the order shown, restarting the server each time: a. Hard disk drive b. Cable from the system board to the backplane c. Hard disk drive backplane (n = hard disk drive number)
- **806f020d-0406ffff : Failure Predicted on drive [StorageVolumeElementName] for array [ComputerSystemElementName]. (Drive 6)**

This message is for the use case when an implementation has detected an Array Failure is Predicted.

May also be shown as 806f020d0406ffff or 0x806f020d0406ffff

**Severity**

Warning



**Serviceable**

Yes

**Automatically notify support**

Yes

**Alert Category**

System - Predicted Failure

**SNMP Trap ID**

27

**CIM Information**

Prefix: PLAT ID: 0168

**User Response**

1. Run the hard disk drive diagnostic test on drive n.
  2. Reseat the following components: a. Hard disk drive (wait 1 minute or more before reinstalling the drive) b. Cable from the system board to the backplane
  3. Replace the following components one at a time, in the order shown, restarting the server each time: a. Hard disk drive b. Cable from the system board to the backplane c. Hard disk drive backplane (n = hard disk drive number)
- **806f020d-0407ffff : Failure Predicted on drive [StorageVolumeElementName] for array [ComputerSystemElementName]. (Drive 7)**

This message is for the use case when an implementation has detected an Array Failure is Predicted.

May also be shown as 806f020d0407ffff or 0x806f020d0407ffff

**Severity**

Warning

**Serviceable**

Yes

**Automatically notify support**

Yes

**Alert Category**

System - Predicted Failure

**SNMP Trap ID**

27

**CIM Information**

Prefix: PLAT ID: 0168

**User Response**

1. Run the hard disk drive diagnostic test on drive n.
  2. Reseat the following components: a. Hard disk drive (wait 1 minute or more before reinstalling the drive) b. Cable from the system board to the backplane
  3. Replace the following components one at a time, in the order shown, restarting the server each time: a. Hard disk drive b. Cable from the system board to the backplane c. Hard disk drive backplane (n = hard disk drive number)
- **806f020d-0408ffff : Failure Predicted on drive [StorageVolumeElementName] for array [ComputerSystemElementName]. (Drive 8)**

This message is for the use case when an implementation has detected an Array Failure is Predicted.

May also be shown as 806f020d0408ffff or 0x806f020d0408ffff

**Severity**

Warning

**Serviceable**

Yes

**Automatically notify support**

Yes

**Alert Category**

System - Predicted Failure

**SNMP Trap ID**

27

**CIM Information**

**Prefix: PLAT ID:** 0168

**User Response**

1. Run the hard disk drive diagnostic test on drive n.
  2. Reseat the following components: a. Hard disk drive (wait 1 minute or more before reinstalling the drive) b. Cable from the system board to the backplane
  3. Replace the following components one at a time, in the order shown, restarting the server each time: a. Hard disk drive b. Cable from the system board to the backplane c. Hard disk drive backplane (n = hard disk drive number)
- **806f020d-0409ffff : Failure Predicted on drive [StorageVolumeElementName] for array [ComputerSystemElementName]. (Drive 9)**

This message is for the use case when an implementation has detected an Array Failure is Predicted.

May also be shown as 806f020d0409ffff or 0x806f020d0409ffff

**Severity**

Warning

**Serviceable**

Yes

**Automatically notify support**

Yes

**Alert Category**

System - Predicted Failure

**SNMP Trap ID**

27

**CIM Information**

**Prefix: PLAT ID:** 0168

**User Response**

1. Run the hard disk drive diagnostic test on drive n.
  2. Reseat the following components: a. Hard disk drive (wait 1 minute or more before reinstalling the drive) b. Cable from the system board to the backplane
  3. Replace the following components one at a time, in the order shown, restarting the server each time: a. Hard disk drive b. Cable from the system board to the backplane c. Hard disk drive backplane (n = hard disk drive number)
- **806f020d-040affff : Failure Predicted on drive [StorageVolumeElementName] for array [ComputerSystemElementName]. (Drive 10)**

This message is for the use case when an implementation has detected an Array Failure is Predicted.

May also be shown as 806f020d040affff or 0x806f020d040affff

**Severity**

Warning

**Serviceable**

Yes

**Automatically notify support**

Yes

**Alert Category**

System - Predicted Failure

**SNMP Trap ID**

27

**CIM Information**

**Prefix: PLAT ID:** 0168

**User Response**

1. Run the hard disk drive diagnostic test on drive n.
  2. Reseat the following components: a. Hard disk drive (wait 1 minute or more before reinstalling the drive) b. Cable from the system board to the backplane
  3. Replace the following components one at a time, in the order shown, restarting the server each time: a. Hard disk drive b. Cable from the system board to the backplane c. Hard disk drive backplane (n = hard disk drive number)
- **806f020d-040bffff : Failure Predicted on drive [StorageVolumeElementName] for array [ComputerSystemElementName]. (Drive 11)**

This message is for the use case when an implementation has detected an Array Failure is Predicted.

May also be shown as 806f020d040bffff or 0x806f020d040bffff

**Severity**

Warning

**Serviceable**

Yes

**Automatically notify support**

Yes

**Alert Category**

System - Predicted Failure

**SNMP Trap ID**

27

**CIM Information**

**Prefix: PLAT ID:** 0168

**User Response**

1. Run the hard disk drive diagnostic test on drive n.
2. Reseat the following components: a. Hard disk drive (wait 1 minute or more before reinstalling the drive) b. Cable from the system board to the backplane
3. Replace the following components one at a time, in the order shown, restarting the server each time: a. Hard disk drive b. Cable from the system board to the backplane c. Hard disk drive backplane (n = hard disk drive number)

- **806f020d-040cffff : Failure Predicted on drive [StorageVolumeElementName] for array [ComputerSystemElementName]. (Drive 12)**

This message is for the use case when an implementation has detected an Array Failure is Predicted.  
May also be shown as 806f020d040cffff or 0x806f020d040cffff

**Severity**

Warning

**Serviceable**

Yes

**Automatically notify support**

Yes

**Alert Category**

System - Predicted Failure

**SNMP Trap ID**

27

**CIM Information**

Prefix: PLAT ID: 0168

**User Response**

1. Run the hard disk drive diagnostic test on drive n.
2. Reseat the following components: a. Hard disk drive (wait 1 minute or more before reinstalling the drive) b. Cable from the system board to the backplane
3. Replace the following components one at a time, in the order shown, restarting the server each time: a. Hard disk drive b. Cable from the system board to the backplane c. Hard disk drive backplane (n = hard disk drive number)

- **806f020d-040dffff : Failure Predicted on drive [StorageVolumeElementName] for array [ComputerSystemElementName]. (Drive 13)**

This message is for the use case when an implementation has detected an Array Failure is Predicted.  
May also be shown as 806f020d040dffff or 0x806f020d040dffff

**Severity**

Warning

**Serviceable**

Yes

**Automatically notify support**

Yes

**Alert Category**

System - Predicted Failure

**SNMP Trap ID**

27

**CIM Information**

Prefix: PLAT ID: 0168

**User Response**

1. Run the hard disk drive diagnostic test on drive n.
2. Reseat the following components: a. Hard disk drive (wait 1 minute or more before reinstalling the drive) b. Cable from the system board to the backplane

3. Replace the following components one at a time, in the order shown, restarting the server each time: a. Hard disk drive b. Cable from the system board to the backplane c. Hard disk drive backplane (n = hard disk drive number)

- **806f020d-040effff : Failure Predicted on drive [StorageVolumeElementName] for array [ComputerSystemElementName]. (Drive 14)**

This message is for the use case when an implementation has detected an Array Failure is Predicted.

May also be shown as 806f020d040effff or 0x806f020d040effff

**Severity**

Warning

**Serviceable**

Yes

**Automatically notify support**

Yes

**Alert Category**

System - Predicted Failure

**SNMP Trap ID**

27

**CIM Information**

**Prefix: PLAT ID:** 0168

**User Response**

1. Run the hard disk drive diagnostic test on drive n.
2. Reseat the following components: a. Hard disk drive (wait 1 minute or more before reinstalling the drive) b. Cable from the system board to the backplane
3. Replace the following components one at a time, in the order shown, restarting the server each time: a. Hard disk drive b. Cable from the system board to the backplane c. Hard disk drive backplane (n = hard disk drive number)

- **806f020d-040fffff : Failure Predicted on drive [StorageVolumeElementName] for array [ComputerSystemElementName]. (Drive 15)**

This message is for the use case when an implementation has detected an Array Failure is Predicted.

May also be shown as 806f020d040fffff or 0x806f020d040fffff

**Severity**

Warning

**Serviceable**

Yes

**Automatically notify support**

Yes

**Alert Category**

System - Predicted Failure

**SNMP Trap ID**

27

**CIM Information**

**Prefix: PLAT ID:** 0168

**User Response**

1. Run the hard disk drive diagnostic test on drive n.

2. Reseat the following components: a. Hard disk drive (wait 1 minute or more before reinstalling the drive) b. Cable from the system board to the backplane
  3. Replace the following components one at a time, in the order shown, restarting the server each time: a. Hard disk drive b. Cable from the system board to the backplane c. Hard disk drive backplane (n = hard disk drive number)
- **806f020d-0410ffff : Failure Predicted on drive [StorageVolumeElementName] for array [ComputerSystemElementName]. (Drive 16)**

This message is for the use case when an implementation has detected an Array Failure is Predicted. May also be shown as 806f020d0410ffff or 0x806f020d0410ffff

**Severity**

Warning

**Serviceable**

Yes

**Automatically notify support**

Yes

**Alert Category**

System - Predicted Failure

**SNMP Trap ID**

27

**CIM Information**

**Prefix: PLAT ID:** 0168

**User Response**

1. Run the hard disk drive diagnostic test on drive n.
  2. Reseat the following components: a. Hard disk drive (wait 1 minute or more before reinstalling the drive) b. Cable from the system board to the backplane
  3. Replace the following components one at a time, in the order shown, restarting the server each time: a. Hard disk drive b. Cable from the system board to the backplane c. Hard disk drive backplane (n = hard disk drive number)
- **806f020d-0411ffff : Failure Predicted on drive [StorageVolumeElementName] for array [ComputerSystemElementName]. (Drive 17)**

This message is for the use case when an implementation has detected an Array Failure is Predicted. May also be shown as 806f020d0411ffff or 0x806f020d0411ffff

**Severity**

Warning

**Serviceable**

Yes

**Automatically notify support**

Yes

**Alert Category**

System - Predicted Failure

**SNMP Trap ID**

27

**CIM Information**

**Prefix: PLAT ID:** 0168

### User Response

1. Run the hard disk drive diagnostic test on drive n.
  2. Reseat the following components: a. Hard disk drive (wait 1 minute or more before reinstalling the drive) b. Cable from the system board to the backplane
  3. Replace the following components one at a time, in the order shown, restarting the server each time: a. Hard disk drive b. Cable from the system board to the backplane c. Hard disk drive backplane (n = hard disk drive number)
- **806f020d-0412ffff : Failure Predicted on drive [StorageVolumeElementName] for array [ComputerSystemElementName]. (Drive 18)**

This message is for the use case when an implementation has detected an Array Failure is Predicted.  
May also be shown as 806f020d0412ffff or 0x806f020d0412ffff

### Severity

Warning

### Serviceable

Yes

### Automatically notify support

Yes

### Alert Category

System - Predicted Failure

### SNMP Trap ID

27

### CIM Information

Prefix: PLAT ID: 0168

### User Response

1. Run the hard disk drive diagnostic test on drive n.
  2. Reseat the following components: a. Hard disk drive (wait 1 minute or more before reinstalling the drive) b. Cable from the system board to the backplane
  3. Replace the following components one at a time, in the order shown, restarting the server each time: a. Hard disk drive b. Cable from the system board to the backplane c. Hard disk drive backplane (n = hard disk drive number)
- **806f020d-0413ffff : Failure Predicted on drive [StorageVolumeElementName] for array [ComputerSystemElementName]. (Drive 19)**

This message is for the use case when an implementation has detected an Array Failure is Predicted.  
May also be shown as 806f020d0413ffff or 0x806f020d0413ffff

### Severity

Warning

### Serviceable

Yes

### Automatically notify support

Yes

### Alert Category

System - Predicted Failure

### SNMP Trap ID

27

**CIM Information**

Prefix: PLAT ID: 0168

**User Response**

1. Run the hard disk drive diagnostic test on drive n.
  2. Reseat the following components: a. Hard disk drive (wait 1 minute or more before reinstalling the drive) b. Cable from the system board to the backplane
  3. Replace the following components one at a time, in the order shown, restarting the server each time: a. Hard disk drive b. Cable from the system board to the backplane c. Hard disk drive backplane (n = hard disk drive number)
- **806f020d-0414ffff : Failure Predicted on drive [StorageVolumeElementName] for array [ComputerSystemElementName]. (Drive 20)**

This message is for the use case when an implementation has detected an Array Failure is Predicted.

May also be shown as 806f020d0414ffff or 0x806f020d0414ffff

**Severity**

Warning

**Serviceable**

Yes

**Automatically notify support**

Yes

**Alert Category**

System - Predicted Failure

**SNMP Trap ID**

27

**CIM Information**

Prefix: PLAT ID: 0168

**User Response**

1. Run the hard disk drive diagnostic test on drive n.
  2. Reseat the following components: a. Hard disk drive (wait 1 minute or more before reinstalling the drive) b. Cable from the system board to the backplane
  3. Replace the following components one at a time, in the order shown, restarting the server each time: a. Hard disk drive b. Cable from the system board to the backplane c. Hard disk drive backplane (n = hard disk drive number)
- **806f020d-0415ffff : Failure Predicted on drive [StorageVolumeElementName] for array [ComputerSystemElementName]. (Drive 21)**

This message is for the use case when an implementation has detected an Array Failure is Predicted.

May also be shown as 806f020d0415ffff or 0x806f020d0415ffff

**Severity**

Warning

**Serviceable**

Yes

**Automatically notify support**

Yes

**Alert Category**

System - Predicted Failure



**SNMP Trap ID**

27

**CIM Information****Prefix:** PLAT ID: 0168**User Response**

1. Run the hard disk drive diagnostic test on drive n.
  2. Reseat the following components: a. Hard disk drive (wait 1 minute or more before reinstalling the drive) b. Cable from the system board to the backplane
  3. Replace the following components one at a time, in the order shown, restarting the server each time: a. Hard disk drive b. Cable from the system board to the backplane c. Hard disk drive backplane (n = hard disk drive number)
- **806f020d-0416ffff : Failure Predicted on drive [StorageVolumeElementName] for array [ComputerSystemElementName]. (Drive 22)**

This message is for the use case when an implementation has detected an Array Failure is Predicted.

May also be shown as 806f020d0416ffff or 0x806f020d0416ffff

**Severity**

Warning

**Serviceable**

Yes

**Automatically notify support**

Yes

**Alert Category**

System - Predicted Failure

**SNMP Trap ID**

27

**CIM Information****Prefix:** PLAT ID: 0168**User Response**

1. Run the hard disk drive diagnostic test on drive n.
  2. Reseat the following components: a. Hard disk drive (wait 1 minute or more before reinstalling the drive) b. Cable from the system board to the backplane
  3. Replace the following components one at a time, in the order shown, restarting the server each time: a. Hard disk drive b. Cable from the system board to the backplane c. Hard disk drive backplane (n = hard disk drive number)
- **806f020d-0417ffff : Failure Predicted on drive [StorageVolumeElementName] for array [ComputerSystemElementName]. (Drive 23)**

This message is for the use case when an implementation has detected an Array Failure is Predicted.

May also be shown as 806f020d0417ffff or 0x806f020d0417ffff

**Severity**

Warning

**Serviceable**

Yes

**Automatically notify support**

Yes

**Alert Category**

System - Predicted Failure

**SNMP Trap ID**

27

**CIM Information**

Prefix: PLAT ID: 0168

**User Response**

1. Run the hard disk drive diagnostic test on drive n.
  2. Reseat the following components: a. Hard disk drive (wait 1 minute or more before reinstalling the drive) b. Cable from the system board to the backplane
  3. Replace the following components one at a time, in the order shown, restarting the server each time: a. Hard disk drive b. Cable from the system board to the backplane c. Hard disk drive backplane (n = hard disk drive number)
- **806f020d-0418ffff : Failure Predicted on drive [StorageVolumeElementName] for array [ComputerSystemElementName]. (Drive 24)**

This message is for the use case when an implementation has detected an Array Failure is Predicted.

May also be shown as 806f020d0418ffff or 0x806f020d0418ffff

**Severity**

Warning

**Serviceable**

Yes

**Automatically notify support**

Yes

**Alert Category**

System - Predicted Failure

**SNMP Trap ID**

27

**CIM Information**

Prefix: PLAT ID: 0168

**User Response**

1. Run the hard disk drive diagnostic test on drive n.
  2. Reseat the following components: a. Hard disk drive (wait 1 minute or more before reinstalling the drive) b. Cable from the system board to the backplane
  3. Replace the following components one at a time, in the order shown, restarting the server each time: a. Hard disk drive b. Cable from the system board to the backplane c. Hard disk drive backplane (n = hard disk drive number)
- **806f020d-0419ffff : Failure Predicted on drive [StorageVolumeElementName] for array [ComputerSystemElementName]. (Drive 25)**

This message is for the use case when an implementation has detected an Array Failure is Predicted.

May also be shown as 806f020d0419ffff or 0x806f020d0419ffff

**Severity**

Warning

**Serviceable**

Yes

**Automatically notify support**

Yes

**Alert Category**

System - Predicted Failure

**SNMP Trap ID**

27

**CIM Information**

**Prefix:** PLAT ID: 0168

**User Response**

1. Run the hard disk drive diagnostic test on drive n.
  2. Reseat the following components: a. Hard disk drive (wait 1 minute or more before reinstalling the drive) b. Cable from the system board to the backplane
  3. Replace the following components one at a time, in the order shown, restarting the server each time: a. Hard disk drive b. Cable from the system board to the backplane c. Hard disk drive backplane (n = hard disk drive number)
- **806f020d-041affff : Failure Predicted on drive [StorageVolumeElementName] for array [ComputerSystemElementName]. (Drive 26)**

This message is for the use case when an implementation has detected an Array Failure is Predicted.

May also be shown as 806f020d041affff or 0x806f020d041affff

**Severity**

Warning

**Serviceable**

Yes

**Automatically notify support**

Yes

**Alert Category**

System - Predicted Failure

**SNMP Trap ID**

27

**CIM Information**

**Prefix:** PLAT ID: 0168

**User Response**

1. Run the hard disk drive diagnostic test on drive n.
  2. Reseat the following components: a. Hard disk drive (wait 1 minute or more before reinstalling the drive) b. Cable from the system board to the backplane
  3. Replace the following components one at a time, in the order shown, restarting the server each time: a. Hard disk drive b. Cable from the system board to the backplane c. Hard disk drive backplane (n = hard disk drive number)
- **806f020d-041bffff : Failure Predicted on drive [StorageVolumeElementName] for array [ComputerSystemElementName]. (Drive 27)**

This message is for the use case when an implementation has detected an Array Failure is Predicted.

May also be shown as 806f020d041bffff or 0x806f020d041bffff

**Severity**

Warning

**Serviceable**

Yes

**Automatically notify support**

Yes

**Alert Category**

System - Predicted Failure

**SNMP Trap ID**

27

**CIM Information**

Prefix: PLAT ID: 0168

**User Response**

1. Run the hard disk drive diagnostic test on drive n.
  2. Reseat the following components: a. Hard disk drive (wait 1 minute or more before reinstalling the drive) b. Cable from the system board to the backplane
  3. Replace the following components one at a time, in the order shown, restarting the server each time: a. Hard disk drive b. Cable from the system board to the backplane c. Hard disk drive backplane (n = hard disk drive number)
- **806f020d-041cffff : Failure Predicted on drive [StorageVolumeElementName] for array [ComputerSystemElementName]. (Drive 28)**

This message is for the use case when an implementation has detected an Array Failure is Predicted.

May also be shown as 806f020d041cffff or 0x806f020d041cffff

**Severity**

Warning

**Serviceable**

Yes

**Automatically notify support**

Yes

**Alert Category**

System - Predicted Failure

**SNMP Trap ID**

27

**CIM Information**

Prefix: PLAT ID: 0168

**User Response**

1. Run the hard disk drive diagnostic test on drive n.
  2. Reseat the following components: a. Hard disk drive (wait 1 minute or more before reinstalling the drive) b. Cable from the system board to the backplane
  3. Replace the following components one at a time, in the order shown, restarting the server each time: a. Hard disk drive b. Cable from the system board to the backplane c. Hard disk drive backplane (n = hard disk drive number)
- **806f020d-041dffff : Failure Predicted on drive [StorageVolumeElementName] for array [ComputerSystemElementName]. (Drive 29)**

This message is for the use case when an implementation has detected an Array Failure is Predicted.

May also be shown as 806f020d041dffff or 0x806f020d041dffff

**Severity**

Warning

**Serviceable**

Yes

**Automatically notify support**

Yes

**Alert Category**

System - Predicted Failure

**SNMP Trap ID**

27

**CIM Information****Prefix:** PLAT ID: 0168**User Response**

1. Run the hard disk drive diagnostic test on drive n.
  2. Reseat the following components: a. Hard disk drive (wait 1 minute or more before reinstalling the drive) b. Cable from the system board to the backplane
  3. Replace the following components one at a time, in the order shown, restarting the server each time: a. Hard disk drive b. Cable from the system board to the backplane c. Hard disk drive backplane (n = hard disk drive number)
- **806f020d-041effff : Failure Predicted on drive [StorageVolumeElementName] for array [ComputerSystemElementName]. (Drive 30)**

This message is for the use case when an implementation has detected an Array Failure is Predicted.

May also be shown as 806f020d041effff or 0x806f020d041effff

**Severity**

Warning

**Serviceable**

Yes

**Automatically notify support**

Yes

**Alert Category**

System - Predicted Failure

**SNMP Trap ID**

27

**CIM Information****Prefix:** PLAT ID: 0168**User Response**

1. Run the hard disk drive diagnostic test on drive n.
  2. Reseat the following components: a. Hard disk drive (wait 1 minute or more before reinstalling the drive) b. Cable from the system board to the backplane
  3. Replace the following components one at a time, in the order shown, restarting the server each time: a. Hard disk drive b. Cable from the system board to the backplane c. Hard disk drive backplane (n = hard disk drive number)
- **806f020d-041fffff : Failure Predicted on drive [StorageVolumeElementName] for array [ComputerSystemElementName]. (Drive 31)**

This message is for the use case when an implementation has detected an Array Failure is Predicted.

May also be shown as 806f020d041ffff or 0x806f020d041ffff

**Severity**

Warning

**Serviceable**

Yes

**Automatically notify support**

Yes

**Alert Category**

System - Predicted Failure

**SNMP Trap ID**

27

**CIM Information**

**Prefix: PLAT ID:** 0168

**User Response**

1. Run the hard disk drive diagnostic test on drive n.
  2. Reseat the following components: a. Hard disk drive (wait 1 minute or more before reinstalling the drive) b. Cable from the system board to the backplane
  3. Replace the following components one at a time, in the order shown, restarting the server each time: a. Hard disk drive b. Cable from the system board to the backplane c. Hard disk drive backplane (n = hard disk drive number)
- **806f020d-0420ffff : Failure Predicted on drive [StorageVolumeElementName] for array [ComputerSystemElementName]. (Ext Drive)**

This message is for the use case when an implementation has detected an Array Failure is Predicted.

May also be shown as 806f020d0420ffff or 0x806f020d0420ffff

**Severity**

Warning

**Serviceable**

Yes

**Automatically notify support**

Yes

**Alert Category**

System - Predicted Failure

**SNMP Trap ID**

27

**CIM Information**

**Prefix: PLAT ID:** 0168

**User Response**

1. Run the hard disk drive diagnostic test on drive n.
2. Reseat the following components: a. Hard disk drive (wait 1 minute or more before reinstalling the drive) b. Cable from the system board to the backplane
3. Replace the following components one at a time, in the order shown, restarting the server each time: a. Hard disk drive b. Cable from the system board to the backplane c. Hard disk drive backplane (n = hard disk drive number)

- **806f0223-2101ffff : Powering off system [ComputerSystemElementName] initiated by [WatchdogElementName]. (IPMI Watchdog)**

This message is for the use case when an implementation has detected a Poweroff by Watchdog has occurred.

May also be shown as 806f02232101ffff or 0x806f02232101ffff

**Severity**

Info

**Serviceable**

No

**Automatically notify support**

No

**Alert Category**

System - Other

**SNMP Trap ID**

**CIM Information**

Prefix: PLAT ID: 0372

**User Response**

No action; information only.

- **806f0308-0a01ffff : [PowerSupplyElementName] has lost input. (Power Supply 1)**

This message is for the use case when an implementation has detected a Power Supply that has input that has been lost.

May also be shown as 806f03080a01ffff or 0x806f03080a01ffff

**Severity**

Info

**Serviceable**

No

**Automatically notify support**

No

**Alert Category**

System - Other

**SNMP Trap ID**

**CIM Information**

Prefix: PLAT ID: 0100

**User Response**

1. Reconnect the power cords.
2. Check power supply n LED.
3. See Power-supply LEDs for more information. (n = power supply number)

- **806f0308-0a02ffff : [PowerSupplyElementName] has lost input. (Power Supply 2)**

This message is for the use case when an implementation has detected a Power Supply that has input that has been lost.

May also be shown as 806f03080a02ffff or 0x806f03080a02ffff

**Severity**

Info

**Serviceable**

No

**Automatically notify support**

No

**Alert Category**

System - Other

**SNMP Trap ID****CIM Information****Prefix:** PLAT ID: 0100**User Response**

1. Reconnect the power cords.
  2. Check power supply n LED.
  3. See Power-supply LEDs for more information. (n = power supply number)
- **806f030c-2001ffff : Scrub Failure for [PhysicalMemoryElementName] on Subsystem [MemoryElementName]. (DIMM 1)**

This message is for the use case when an implementation has detected a Memory Scrub failure.

May also be shown as 806f030c2001ffff or 0x806f030c2001ffff

**Severity**

Error

**Serviceable**

Yes

**Automatically notify support**

No

**Alert Category**

Critical - Memory

**SNMP Trap ID**

41

**CIM Information****Prefix:** PLAT ID: 0136**User Response**

Note: Each time you install or remove a DIMM, you must disconnect the server from the power source; then, wait 10 seconds before restarting the server.

1. Refer to TIP H212293 for minimum code level.
2. Check the Lenovo support website for an applicable retain tip or firmware update that applies to this memory error.
3. Make sure that the DIMMs are firmly seated and no foreign material is found in the DIMM connector. Then, retry with the same DIMM.
4. If the problem is related to a DIMM, replace the failing DIMM indicated by the error LEDs.
5. If the problem occurs on the same DIMM connector, swap the affected DIMMs (as indicated by the error LEDs on the system board or the event logs) to a different memory channel or microprocessor.



6. (Trained technician only) If the problem occurs on the same DIMM connector, check the DIMM connector. If the connector contains any foreign material or is damaged, replace the system board.
  7. (Trained service technician only) Remove the affected microprocessor and check the microprocessor socket pins for any damaged pins. If a damage is found, replace the system board.
  8. (Trained service technician only) If the problem is related to microprocessor socket pins, replace the system board.
- **806f030c-2002ffff : Scrub Failure for [PhysicalMemoryElementName] on Subsystem [MemoryElementName]. (DIMM 2)**

This message is for the use case when an implementation has detected a Memory Scrub failure.

May also be shown as 806f030c2002ffff or 0x806f030c2002ffff

**Severity**

Error

**Serviceable**

Yes

**Automatically notify support**

No

**Alert Category**

Critical - Memory

**SNMP Trap ID**

41

**CIM Information**

Prefix: PLAT ID: 0136

**User Response**

Note: Each time you install or remove a DIMM, you must disconnect the server from the power source; then, wait 10 seconds before restarting the server.

1. Refer to TIP H212293 for minimum code level.
  2. Check the Lenovo support website for an applicable retain tip or firmware update that applies to this memory error.
  3. Make sure that the DIMMs are firmly seated and no foreign material is found in the DIMM connector. Then, retry with the same DIMM.
  4. If the problem is related to a DIMM, replace the failing DIMM indicated by the error LEDs.
  5. If the problem occurs on the same DIMM connector, swap the affected DIMMs (as indicated by the error LEDs on the system board or the event logs) to a different memory channel or microprocessor.
  6. (Trained technician only) If the problem occurs on the same DIMM connector, check the DIMM connector. If the connector contains any foreign material or is damaged, replace the system board.
  7. (Trained service technician only) Remove the affected microprocessor and check the microprocessor socket pins for any damaged pins. If a damage is found, replace the system board.
  8. (Trained service technician only) If the problem is related to microprocessor socket pins, replace the system board.
- **806f030c-2003ffff : Scrub Failure for [PhysicalMemoryElementName] on Subsystem [MemoryElementName]. (DIMM 3)**

This message is for the use case when an implementation has detected a Memory Scrub failure.  
May also be shown as 806f030c2003ffff or 0x806f030c2003ffff

**Severity**

Error

**Serviceable**

Yes

**Automatically notify support**

No

**Alert Category**

Critical - Memory

**SNMP Trap ID**

41

**CIM Information**

Prefix: PLAT ID: 0136

**User Response**

Note: Each time you install or remove a DIMM, you must disconnect the server from the power source; then, wait 10 seconds before restarting the server.

1. Refer to TIP H212293 for minimum code level.
2. Check the Lenovo support website for an applicable retain tip or firmware update that applies to this memory error.
3. Make sure that the DIMMs are firmly seated and no foreign material is found in the DIMM connector. Then, retry with the same DIMM.
4. If the problem is related to a DIMM, replace the failing DIMM indicated by the error LEDs.
5. If the problem occurs on the same DIMM connector, swap the affected DIMMs (as indicated by the error LEDs on the system board or the event logs) to a different memory channel or microprocessor.
6. (Trained technician only) If the problem occurs on the same DIMM connector, check the DIMM connector. If the connector contains any foreign material or is damaged, replace the system board.
7. (Trained service technician only) Remove the affected microprocessor and check the microprocessor socket pins for any damaged pins. If a damage is found, replace the system board.
8. (Trained service technician only) If the problem is related to microprocessor socket pins, replace the system board.

• **806f030c-2004ffff : Scrub Failure for [PhysicalMemoryElementName] on Subsystem [MemoryElementName]. (DIMM 4)**

This message is for the use case when an implementation has detected a Memory Scrub failure.  
May also be shown as 806f030c2004ffff or 0x806f030c2004ffff

**Severity**

Error

**Serviceable**

Yes

**Automatically notify support**

No

**Alert Category**

Critical - Memory

**SNMP Trap ID**

41

**CIM Information**

**Prefix:** PLAT ID: 0136

**User Response**

Note: Each time you install or remove a DIMM, you must disconnect the server from the power source; then, wait 10 seconds before restarting the server.

1. Refer to TIP H212293 for minimum code level.
  2. Check the Lenovo support website for an applicable retain tip or firmware update that applies to this memory error.
  3. Make sure that the DIMMs are firmly seated and no foreign material is found in the DIMM connector. Then, retry with the same DIMM.
  4. If the problem is related to a DIMM, replace the failing DIMM indicated by the error LEDs.
  5. If the problem occurs on the same DIMM connector, swap the affected DIMMs (as indicated by the error LEDs on the system board or the event logs) to a different memory channel or microprocessor.
  6. (Trained technician only) If the problem occurs on the same DIMM connector, check the DIMM connector. If the connector contains any foreign material or is damaged, replace the system board.
  7. (Trained service technician only) Remove the affected microprocessor and check the microprocessor socket pins for any damaged pins. If a damage is found, replace the system board.
  8. (Trained service technician only) If the problem is related to microprocessor socket pins, replace the system board.
- **806f030c-2005ffff : Scrub Failure for [PhysicalMemoryElementName] on Subsystem [MemoryElementName]. (DIMM 5)**

This message is for the use case when an implementation has detected a Memory Scrub failure.

May also be shown as 806f030c2005ffff or 0x806f030c2005ffff

**Severity**

Error

**Serviceable**

Yes

**Automatically notify support**

No

**Alert Category**

Critical - Memory

**SNMP Trap ID**

41

**CIM Information**

**Prefix:** PLAT ID: 0136

**User Response**

Note: Each time you install or remove a DIMM, you must disconnect the server from the power source; then, wait 10 seconds before restarting the server.

1. Refer to TIP H212293 for minimum code level.

2. Check the Lenovo support website for an applicable retain tip or firmware update that applies to this memory error.
  3. Make sure that the DIMMs are firmly seated and no foreign material is found in the DIMM connector. Then, retry with the same DIMM.
  4. If the problem is related to a DIMM, replace the failing DIMM indicated by the error LEDs.
  5. If the problem occurs on the same DIMM connector, swap the affected DIMMs (as indicated by the error LEDs on the system board or the event logs) to a different memory channel or microprocessor.
  6. (Trained technician only) If the problem occurs on the same DIMM connector, check the DIMM connector. If the connector contains any foreign material or is damaged, replace the system board.
  7. (Trained service technician only) Remove the affected microprocessor and check the microprocessor socket pins for any damaged pins. If a damage is found, replace the system board.
  8. (Trained service technician only) If the problem is related to microprocessor socket pins, replace the system board.
- **806f030c-2006ffff : Scrub Failure for [PhysicalMemoryElementName] on Subsystem [MemoryElementName]. (DIMM 6)**

This message is for the use case when an implementation has detected a Memory Scrub failure.

May also be shown as 806f030c2006ffff or 0x806f030c2006ffff

**Severity**

Error

**Serviceable**

Yes

**Automatically notify support**

No

**Alert Category**

Critical - Memory

**SNMP Trap ID**

41

**CIM Information**

**Prefix:** PLAT ID: 0136

**User Response**

Note: Each time you install or remove a DIMM, you must disconnect the server from the power source; then, wait 10 seconds before restarting the server.

1. Refer to TIP H212293 for minimum code level.
2. Check the Lenovo support website for an applicable retain tip or firmware update that applies to this memory error.
3. Make sure that the DIMMs are firmly seated and no foreign material is found in the DIMM connector. Then, retry with the same DIMM.
4. If the problem is related to a DIMM, replace the failing DIMM indicated by the error LEDs.
5. If the problem occurs on the same DIMM connector, swap the affected DIMMs (as indicated by the error LEDs on the system board or the event logs) to a different memory channel or microprocessor.

6. (Trained technician only) If the problem occurs on the same DIMM connector, check the DIMM connector. If the connector contains any foreign material or is damaged, replace the system board.
  7. (Trained service technician only) Remove the affected microprocessor and check the microprocessor socket pins for any damaged pins. If a damage is found, replace the system board.
  8. (Trained service technician only) If the problem is related to microprocessor socket pins, replace the system board.
- **806f030c-2007ffff : Scrub Failure for [PhysicalMemoryElementName] on Subsystem [MemoryElementName]. (DIMM 7)**

This message is for the use case when an implementation has detected a Memory Scrub failure.

May also be shown as 806f030c2007ffff or 0x806f030c2007ffff

**Severity**

Error

**Serviceable**

Yes

**Automatically notify support**

No

**Alert Category**

Critical - Memory

**SNMP Trap ID**

41

**CIM Information**

Prefix: PLAT ID: 0136

**User Response**

Note: Each time you install or remove a DIMM, you must disconnect the server from the power source; then, wait 10 seconds before restarting the server.

1. Refer to TIP H212293 for minimum code level.
  2. Check the Lenovo support website for an applicable retain tip or firmware update that applies to this memory error.
  3. Make sure that the DIMMs are firmly seated and no foreign material is found in the DIMM connector. Then, retry with the same DIMM.
  4. If the problem is related to a DIMM, replace the failing DIMM indicated by the error LEDs.
  5. If the problem occurs on the same DIMM connector, swap the affected DIMMs (as indicated by the error LEDs on the system board or the event logs) to a different memory channel or microprocessor.
  6. (Trained technician only) If the problem occurs on the same DIMM connector, check the DIMM connector. If the connector contains any foreign material or is damaged, replace the system board.
  7. (Trained service technician only) Remove the affected microprocessor and check the microprocessor socket pins for any damaged pins. If a damage is found, replace the system board.
  8. (Trained service technician only) If the problem is related to microprocessor socket pins, replace the system board.
- **806f030c-2008ffff : Scrub Failure for [PhysicalMemoryElementName] on Subsystem [MemoryElementName]. (DIMM 8)**

This message is for the use case when an implementation has detected a Memory Scrub failure.  
May also be shown as 806f030c2008ffff or 0x806f030c2008ffff

**Severity**

Error

**Serviceable**

Yes

**Automatically notify support**

No

**Alert Category**

Critical - Memory

**SNMP Trap ID**

41

**CIM Information**

Prefix: PLAT ID: 0136

**User Response**

Note: Each time you install or remove a DIMM, you must disconnect the server from the power source; then, wait 10 seconds before restarting the server.

1. Refer to TIP H212293 for minimum code level.
  2. Check the Lenovo support website for an applicable retain tip or firmware update that applies to this memory error.
  3. Make sure that the DIMMs are firmly seated and no foreign material is found in the DIMM connector. Then, retry with the same DIMM.
  4. If the problem is related to a DIMM, replace the failing DIMM indicated by the error LEDs.
  5. If the problem occurs on the same DIMM connector, swap the affected DIMMs (as indicated by the error LEDs on the system board or the event logs) to a different memory channel or microprocessor.
  6. (Trained technician only) If the problem occurs on the same DIMM connector, check the DIMM connector. If the connector contains any foreign material or is damaged, replace the system board.
  7. (Trained service technician only) Remove the affected microprocessor and check the microprocessor socket pins for any damaged pins. If a damage is found, replace the system board.
  8. (Trained service technician only) If the problem is related to microprocessor socket pins, replace the system board.
- **806f030c-2009ffff : Scrub Failure for [PhysicalMemoryElementName] on Subsystem [MemoryElementName]. (DIMM 9)**

This message is for the use case when an implementation has detected a Memory Scrub failure.

May also be shown as 806f030c2009ffff or 0x806f030c2009ffff

**Severity**

Error

**Serviceable**

Yes

**Automatically notify support**

No

**Alert Category**

Critical - Memory

**SNMP Trap ID**

41

**CIM Information**

**Prefix:** PLAT ID: 0136

**User Response**

Note: Each time you install or remove a DIMM, you must disconnect the server from the power source; then, wait 10 seconds before restarting the server.

1. Refer to TIP H212293 for minimum code level.
  2. Check the Lenovo support website for an applicable retain tip or firmware update that applies to this memory error.
  3. Make sure that the DIMMs are firmly seated and no foreign material is found in the DIMM connector. Then, retry with the same DIMM.
  4. If the problem is related to a DIMM, replace the failing DIMM indicated by the error LEDs.
  5. If the problem occurs on the same DIMM connector, swap the affected DIMMs (as indicated by the error LEDs on the system board or the event logs) to a different memory channel or microprocessor.
  6. (Trained technician only) If the problem occurs on the same DIMM connector, check the DIMM connector. If the connector contains any foreign material or is damaged, replace the system board.
  7. (Trained service technician only) Remove the affected microprocessor and check the microprocessor socket pins for any damaged pins. If a damage is found, replace the system board.
  8. (Trained service technician only) If the problem is related to microprocessor socket pins, replace the system board.
- **806f030c-200affff : Scrub Failure for [PhysicalMemoryElementName] on Subsystem [MemoryElementName]. (DIMM 10)**

This message is for the use case when an implementation has detected a Memory Scrub failure.

May also be shown as 806f030c200affff or 0x806f030c200affff

**Severity**

Error

**Serviceable**

Yes

**Automatically notify support**

No

**Alert Category**

Critical - Memory

**SNMP Trap ID**

41

**CIM Information**

**Prefix:** PLAT ID: 0136

**User Response**

Note: Each time you install or remove a DIMM, you must disconnect the server from the power source; then, wait 10 seconds before restarting the server.

1. Refer to TIP H212293 for minimum code level.

2. Check the Lenovo support website for an applicable retain tip or firmware update that applies to this memory error.
  3. Make sure that the DIMMs are firmly seated and no foreign material is found in the DIMM connector. Then, retry with the same DIMM.
  4. If the problem is related to a DIMM, replace the failing DIMM indicated by the error LEDs.
  5. If the problem occurs on the same DIMM connector, swap the affected DIMMs (as indicated by the error LEDs on the system board or the event logs) to a different memory channel or microprocessor.
  6. (Trained technician only) If the problem occurs on the same DIMM connector, check the DIMM connector. If the connector contains any foreign material or is damaged, replace the system board.
  7. (Trained service technician only) Remove the affected microprocessor and check the microprocessor socket pins for any damaged pins. If a damage is found, replace the system board.
  8. (Trained service technician only) If the problem is related to microprocessor socket pins, replace the system board.
- **806f030c-200bffff : Scrub Failure for [PhysicalMemoryElementName] on Subsystem [MemoryElementName]. (DIMM 11)**

This message is for the use case when an implementation has detected a Memory Scrub failure.

May also be shown as 806f030c200bffff or 0x806f030c200bffff

**Severity**

Error

**Serviceable**

Yes

**Automatically notify support**

No

**Alert Category**

Critical - Memory

**SNMP Trap ID**

41

**CIM Information**

**Prefix:** PLAT ID: 0136

**User Response**

Note: Each time you install or remove a DIMM, you must disconnect the server from the power source; then, wait 10 seconds before restarting the server.

1. Refer to TIP H212293 for minimum code level.
2. Check the Lenovo support website for an applicable retain tip or firmware update that applies to this memory error.
3. Make sure that the DIMMs are firmly seated and no foreign material is found in the DIMM connector. Then, retry with the same DIMM.
4. If the problem is related to a DIMM, replace the failing DIMM indicated by the error LEDs.
5. If the problem occurs on the same DIMM connector, swap the affected DIMMs (as indicated by the error LEDs on the system board or the event logs) to a different memory channel or microprocessor.



6. (Trained technician only) If the problem occurs on the same DIMM connector, check the DIMM connector. If the connector contains any foreign material or is damaged, replace the system board.
  7. (Trained service technician only) Remove the affected microprocessor and check the microprocessor socket pins for any damaged pins. If a damage is found, replace the system board.
  8. (Trained service technician only) If the problem is related to microprocessor socket pins, replace the system board.
- **806f030c-200cffff : Scrub Failure for [PhysicalMemoryElementName] on Subsystem [MemoryElementName]. (DIMM 12)**

This message is for the use case when an implementation has detected a Memory Scrub failure.

May also be shown as 806f030c200cffff or 0x806f030c200cffff

**Severity**

Error

**Serviceable**

Yes

**Automatically notify support**

No

**Alert Category**

Critical - Memory

**SNMP Trap ID**

41

**CIM Information**

Prefix: PLAT ID: 0136

**User Response**

Note: Each time you install or remove a DIMM, you must disconnect the server from the power source; then, wait 10 seconds before restarting the server.

1. Refer to TIP H212293 for minimum code level.
  2. Check the Lenovo support website for an applicable retain tip or firmware update that applies to this memory error.
  3. Make sure that the DIMMs are firmly seated and no foreign material is found in the DIMM connector. Then, retry with the same DIMM.
  4. If the problem is related to a DIMM, replace the failing DIMM indicated by the error LEDs.
  5. If the problem occurs on the same DIMM connector, swap the affected DIMMs (as indicated by the error LEDs on the system board or the event logs) to a different memory channel or microprocessor.
  6. (Trained technician only) If the problem occurs on the same DIMM connector, check the DIMM connector. If the connector contains any foreign material or is damaged, replace the system board.
  7. (Trained service technician only) Remove the affected microprocessor and check the microprocessor socket pins for any damaged pins. If a damage is found, replace the system board.
  8. (Trained service technician only) If the problem is related to microprocessor socket pins, replace the system board.
- **806f030c-200dffff : Scrub Failure for [PhysicalMemoryElementName] on Subsystem [MemoryElementName]. (DIMM 13)**

This message is for the use case when an implementation has detected a Memory Scrub failure.  
May also be shown as 806f030c200dffff or 0x806f030c200dffff

**Severity**

Error

**Serviceable**

Yes

**Automatically notify support**

No

**Alert Category**

Critical - Memory

**SNMP Trap ID**

41

**CIM Information**

Prefix: PLAT ID: 0136

**User Response**

Note: Each time you install or remove a DIMM, you must disconnect the server from the power source; then, wait 10 seconds before restarting the server.

1. Refer to TIP H212293 for minimum code level.
  2. Check the Lenovo support website for an applicable retain tip or firmware update that applies to this memory error.
  3. Make sure that the DIMMs are firmly seated and no foreign material is found in the DIMM connector. Then, retry with the same DIMM.
  4. If the problem is related to a DIMM, replace the failing DIMM indicated by the error LEDs.
  5. If the problem occurs on the same DIMM connector, swap the affected DIMMs (as indicated by the error LEDs on the system board or the event logs) to a different memory channel or microprocessor.
  6. (Trained technician only) If the problem occurs on the same DIMM connector, check the DIMM connector. If the connector contains any foreign material or is damaged, replace the system board.
  7. (Trained service technician only) Remove the affected microprocessor and check the microprocessor socket pins for any damaged pins. If a damage is found, replace the system board.
  8. (Trained service technician only) If the problem is related to microprocessor socket pins, replace the system board.
- **806f030c-200effff : Scrub Failure for [PhysicalMemoryElementName] on Subsystem [MemoryElementName]. (DIMM 14)**

This message is for the use case when an implementation has detected a Memory Scrub failure.  
May also be shown as 806f030c200effff or 0x806f030c200effff

**Severity**

Error

**Serviceable**

Yes

**Automatically notify support**

No

**Alert Category**

Critical - Memory

**SNMP Trap ID**

41

**CIM Information****Prefix:** PLAT ID: 0136**User Response**

Note: Each time you install or remove a DIMM, you must disconnect the server from the power source; then, wait 10 seconds before restarting the server.

1. Refer to TIP H212293 for minimum code level.
  2. Check the Lenovo support website for an applicable retain tip or firmware update that applies to this memory error.
  3. Make sure that the DIMMs are firmly seated and no foreign material is found in the DIMM connector. Then, retry with the same DIMM.
  4. If the problem is related to a DIMM, replace the failing DIMM indicated by the error LEDs.
  5. If the problem occurs on the same DIMM connector, swap the affected DIMMs (as indicated by the error LEDs on the system board or the event logs) to a different memory channel or microprocessor.
  6. (Trained technician only) If the problem occurs on the same DIMM connector, check the DIMM connector. If the connector contains any foreign material or is damaged, replace the system board.
  7. (Trained service technician only) Remove the affected microprocessor and check the microprocessor socket pins for any damaged pins. If a damage is found, replace the system board.
  8. (Trained service technician only) If the problem is related to microprocessor socket pins, replace the system board.
- **806f030c-200ffff : Scrub Failure for [PhysicalMemoryElementName] on Subsystem [MemoryElementName]. (DIMM 15)**

This message is for the use case when an implementation has detected a Memory Scrub failure.

May also be shown as 806f030c200ffff or 0x806f030c200ffff

**Severity**

Error

**Serviceable**

Yes

**Automatically notify support**

No

**Alert Category**

Critical - Memory

**SNMP Trap ID**

41

**CIM Information****Prefix:** PLAT ID: 0136**User Response**

Note: Each time you install or remove a DIMM, you must disconnect the server from the power source; then, wait 10 seconds before restarting the server.

1. Refer to TIP H212293 for minimum code level.

2. Check the Lenovo support website for an applicable retain tip or firmware update that applies to this memory error.
  3. Make sure that the DIMMs are firmly seated and no foreign material is found in the DIMM connector. Then, retry with the same DIMM.
  4. If the problem is related to a DIMM, replace the failing DIMM indicated by the error LEDs.
  5. If the problem occurs on the same DIMM connector, swap the affected DIMMs (as indicated by the error LEDs on the system board or the event logs) to a different memory channel or microprocessor.
  6. (Trained technician only) If the problem occurs on the same DIMM connector, check the DIMM connector. If the connector contains any foreign material or is damaged, replace the system board.
  7. (Trained service technician only) Remove the affected microprocessor and check the microprocessor socket pins for any damaged pins. If a damage is found, replace the system board.
  8. (Trained service technician only) If the problem is related to microprocessor socket pins, replace the system board.
- **806f030c-2010ffff : Scrub Failure for [PhysicalMemoryElementName] on Subsystem [MemoryElementName]. (DIMM 16)**

This message is for the use case when an implementation has detected a Memory Scrub failure.

May also be shown as 806f030c2010ffff or 0x806f030c2010ffff

**Severity**

Error

**Serviceable**

Yes

**Automatically notify support**

No

**Alert Category**

Critical - Memory

**SNMP Trap ID**

41

**CIM Information**

**Prefix:** PLAT ID: 0136

**User Response**

Note: Each time you install or remove a DIMM, you must disconnect the server from the power source; then, wait 10 seconds before restarting the server.

1. Refer to TIP H212293 for minimum code level.
2. Check the Lenovo support website for an applicable retain tip or firmware update that applies to this memory error.
3. Make sure that the DIMMs are firmly seated and no foreign material is found in the DIMM connector. Then, retry with the same DIMM.
4. If the problem is related to a DIMM, replace the failing DIMM indicated by the error LEDs.
5. If the problem occurs on the same DIMM connector, swap the affected DIMMs (as indicated by the error LEDs on the system board or the event logs) to a different memory channel or microprocessor.

6. (Trained technician only) If the problem occurs on the same DIMM connector, check the DIMM connector. If the connector contains any foreign material or is damaged, replace the system board.
  7. (Trained service technician only) Remove the affected microprocessor and check the microprocessor socket pins for any damaged pins. If a damage is found, replace the system board.
  8. (Trained service technician only) If the problem is related to microprocessor socket pins, replace the system board.
- **806f030c-2011ffff : Scrub Failure for [PhysicalMemoryElementName] on Subsystem [MemoryElementName]. (DIMM 17)**

This message is for the use case when an implementation has detected a Memory Scrub failure.

May also be shown as 806f030c2011ffff or 0x806f030c2011ffff

**Severity**

Error

**Serviceable**

Yes

**Automatically notify support**

No

**Alert Category**

Critical - Memory

**SNMP Trap ID**

41

**CIM Information**

**Prefix: PLAT ID:** 0136

**User Response**

Note: Each time you install or remove a DIMM, you must disconnect the server from the power source; then, wait 10 seconds before restarting the server.

1. Refer to TIP H212293 for minimum code level.
  2. Check the Lenovo support website for an applicable retain tip or firmware update that applies to this memory error.
  3. Make sure that the DIMMs are firmly seated and no foreign material is found in the DIMM connector. Then, retry with the same DIMM.
  4. If the problem is related to a DIMM, replace the failing DIMM indicated by the error LEDs.
  5. If the problem occurs on the same DIMM connector, swap the affected DIMMs (as indicated by the error LEDs on the system board or the event logs) to a different memory channel or microprocessor.
  6. (Trained technician only) If the problem occurs on the same DIMM connector, check the DIMM connector. If the connector contains any foreign material or is damaged, replace the system board.
  7. (Trained service technician only) Remove the affected microprocessor and check the microprocessor socket pins for any damaged pins. If a damage is found, replace the system board.
  8. (Trained service technician only) If the problem is related to microprocessor socket pins, replace the system board.
- **806f030c-2012ffff : Scrub Failure for [PhysicalMemoryElementName] on Subsystem [MemoryElementName]. (DIMM 18)**

This message is for the use case when an implementation has detected a Memory Scrub failure.  
May also be shown as 806f030c2012ffff or 0x806f030c2012ffff

**Severity**

Error

**Serviceable**

Yes

**Automatically notify support**

No

**Alert Category**

Critical - Memory

**SNMP Trap ID**

41

**CIM Information**

Prefix: PLAT ID: 0136

**User Response**

Note: Each time you install or remove a DIMM, you must disconnect the server from the power source; then, wait 10 seconds before restarting the server.

1. Refer to TIP H212293 for minimum code level.
  2. Check the Lenovo support website for an applicable retain tip or firmware update that applies to this memory error.
  3. Make sure that the DIMMs are firmly seated and no foreign material is found in the DIMM connector. Then, retry with the same DIMM.
  4. If the problem is related to a DIMM, replace the failing DIMM indicated by the error LEDs.
  5. If the problem occurs on the same DIMM connector, swap the affected DIMMs (as indicated by the error LEDs on the system board or the event logs) to a different memory channel or microprocessor.
  6. (Trained technician only) If the problem occurs on the same DIMM connector, check the DIMM connector. If the connector contains any foreign material or is damaged, replace the system board.
  7. (Trained service technician only) Remove the affected microprocessor and check the microprocessor socket pins for any damaged pins. If a damage is found, replace the system board.
  8. (Trained service technician only) If the problem is related to microprocessor socket pins, replace the system board.
- **806f030c-2013ffff : Scrub Failure for [PhysicalMemoryElementName] on Subsystem [MemoryElementName]. (DIMM 19)**

This message is for the use case when an implementation has detected a Memory Scrub failure.  
May also be shown as 806f030c2013ffff or 0x806f030c2013ffff

**Severity**

Error

**Serviceable**

Yes

**Automatically notify support**

No

**Alert Category**

Critical - Memory

**SNMP Trap ID**

41

**CIM Information**

**Prefix:** PLAT ID: 0136

**User Response**

Note: Each time you install or remove a DIMM, you must disconnect the server from the power source; then, wait 10 seconds before restarting the server.

1. Refer to TIP H212293 for minimum code level.
  2. Check the Lenovo support website for an applicable retain tip or firmware update that applies to this memory error.
  3. Make sure that the DIMMs are firmly seated and no foreign material is found in the DIMM connector. Then, retry with the same DIMM.
  4. If the problem is related to a DIMM, replace the failing DIMM indicated by the error LEDs.
  5. If the problem occurs on the same DIMM connector, swap the affected DIMMs (as indicated by the error LEDs on the system board or the event logs) to a different memory channel or microprocessor.
  6. (Trained technician only) If the problem occurs on the same DIMM connector, check the DIMM connector. If the connector contains any foreign material or is damaged, replace the system board.
  7. (Trained service technician only) Remove the affected microprocessor and check the microprocessor socket pins for any damaged pins. If a damage is found, replace the system board.
  8. (Trained service technician only) If the problem is related to microprocessor socket pins, replace the system board.
- **806f030c-2014ffff : Scrub Failure for [PhysicalMemoryElementName] on Subsystem [MemoryElementName]. (DIMM 20)**

This message is for the use case when an implementation has detected a Memory Scrub failure.

May also be shown as 806f030c2014ffff or 0x806f030c2014ffff

**Severity**

Error

**Serviceable**

Yes

**Automatically notify support**

No

**Alert Category**

Critical - Memory

**SNMP Trap ID**

41

**CIM Information**

**Prefix:** PLAT ID: 0136

**User Response**

Note: Each time you install or remove a DIMM, you must disconnect the server from the power source; then, wait 10 seconds before restarting the server.

1. Refer to TIP H212293 for minimum code level.

2. Check the Lenovo support website for an applicable retain tip or firmware update that applies to this memory error.
  3. Make sure that the DIMMs are firmly seated and no foreign material is found in the DIMM connector. Then, retry with the same DIMM.
  4. If the problem is related to a DIMM, replace the failing DIMM indicated by the error LEDs.
  5. If the problem occurs on the same DIMM connector, swap the affected DIMMs (as indicated by the error LEDs on the system board or the event logs) to a different memory channel or microprocessor.
  6. (Trained technician only) If the problem occurs on the same DIMM connector, check the DIMM connector. If the connector contains any foreign material or is damaged, replace the system board.
  7. (Trained service technician only) Remove the affected microprocessor and check the microprocessor socket pins for any damaged pins. If a damage is found, replace the system board.
  8. (Trained service technician only) If the problem is related to microprocessor socket pins, replace the system board.
- **806f030c-2015ffff : Scrub Failure for [PhysicalMemoryElementName] on Subsystem [MemoryElementName]. (DIMM 21)**

This message is for the use case when an implementation has detected a Memory Scrub failure.

May also be shown as 806f030c2015ffff or 0x806f030c2015ffff

**Severity**

Error

**Serviceable**

Yes

**Automatically notify support**

No

**Alert Category**

Critical - Memory

**SNMP Trap ID**

41

**CIM Information**

**Prefix:** PLAT ID: 0136

**User Response**

Note: Each time you install or remove a DIMM, you must disconnect the server from the power source; then, wait 10 seconds before restarting the server.

1. Refer to TIP H212293 for minimum code level.
2. Check the Lenovo support website for an applicable retain tip or firmware update that applies to this memory error.
3. Make sure that the DIMMs are firmly seated and no foreign material is found in the DIMM connector. Then, retry with the same DIMM.
4. If the problem is related to a DIMM, replace the failing DIMM indicated by the error LEDs.
5. If the problem occurs on the same DIMM connector, swap the affected DIMMs (as indicated by the error LEDs on the system board or the event logs) to a different memory channel or microprocessor.



6. (Trained technician only) If the problem occurs on the same DIMM connector, check the DIMM connector. If the connector contains any foreign material or is damaged, replace the system board.
  7. (Trained service technician only) Remove the affected microprocessor and check the microprocessor socket pins for any damaged pins. If a damage is found, replace the system board.
  8. (Trained service technician only) If the problem is related to microprocessor socket pins, replace the system board.
- **806f030c-2016ffff : Scrub Failure for [PhysicalMemoryElementName] on Subsystem [MemoryElementName]. (DIMM 22)**

This message is for the use case when an implementation has detected a Memory Scrub failure.

May also be shown as 806f030c2016ffff or 0x806f030c2016ffff

**Severity**

Error

**Serviceable**

Yes

**Automatically notify support**

No

**Alert Category**

Critical - Memory

**SNMP Trap ID**

41

**CIM Information**

**Prefix: PLAT ID:** 0136

**User Response**

Note: Each time you install or remove a DIMM, you must disconnect the server from the power source; then, wait 10 seconds before restarting the server.

1. Refer to TIP H212293 for minimum code level.
  2. Check the Lenovo support website for an applicable retain tip or firmware update that applies to this memory error.
  3. Make sure that the DIMMs are firmly seated and no foreign material is found in the DIMM connector. Then, retry with the same DIMM.
  4. If the problem is related to a DIMM, replace the failing DIMM indicated by the error LEDs.
  5. If the problem occurs on the same DIMM connector, swap the affected DIMMs (as indicated by the error LEDs on the system board or the event logs) to a different memory channel or microprocessor.
  6. (Trained technician only) If the problem occurs on the same DIMM connector, check the DIMM connector. If the connector contains any foreign material or is damaged, replace the system board.
  7. (Trained service technician only) Remove the affected microprocessor and check the microprocessor socket pins for any damaged pins. If a damage is found, replace the system board.
  8. (Trained service technician only) If the problem is related to microprocessor socket pins, replace the system board.
- **806f030c-2017ffff : Scrub Failure for [PhysicalMemoryElementName] on Subsystem [MemoryElementName]. (DIMM 23)**

This message is for the use case when an implementation has detected a Memory Scrub failure.  
May also be shown as 806f030c2017ffff or 0x806f030c2017ffff

**Severity**

Error

**Serviceable**

Yes

**Automatically notify support**

No

**Alert Category**

Critical - Memory

**SNMP Trap ID**

41

**CIM Information**

Prefix: PLAT ID: 0136

**User Response**

Note: Each time you install or remove a DIMM, you must disconnect the server from the power source; then, wait 10 seconds before restarting the server.

1. Refer to TIP H212293 for minimum code level.
2. Check the Lenovo support website for an applicable retain tip or firmware update that applies to this memory error.
3. Make sure that the DIMMs are firmly seated and no foreign material is found in the DIMM connector. Then, retry with the same DIMM.
4. If the problem is related to a DIMM, replace the failing DIMM indicated by the error LEDs.
5. If the problem occurs on the same DIMM connector, swap the affected DIMMs (as indicated by the error LEDs on the system board or the event logs) to a different memory channel or microprocessor.
6. (Trained technician only) If the problem occurs on the same DIMM connector, check the DIMM connector. If the connector contains any foreign material or is damaged, replace the system board.
7. (Trained service technician only) Remove the affected microprocessor and check the microprocessor socket pins for any damaged pins. If a damage is found, replace the system board.
8. (Trained service technician only) If the problem is related to microprocessor socket pins, replace the system board.

- **806f030c-2018ffff : Scrub Failure for [PhysicalMemoryElementName] on Subsystem [MemoryElementName]. (DIMM 24)**

This message is for the use case when an implementation has detected a Memory Scrub failure.  
May also be shown as 806f030c2018ffff or 0x806f030c2018ffff

**Severity**

Error

**Serviceable**

Yes

**Automatically notify support**

No

**Alert Category**

Critical - Memory

**SNMP Trap ID**

41

**CIM Information**

**Prefix:** PLAT ID: 0136

**User Response**

Note: Each time you install or remove a DIMM, you must disconnect the server from the power source; then, wait 10 seconds before restarting the server.

1. Refer to TIP H212293 for minimum code level.
  2. Check the Lenovo support website for an applicable retain tip or firmware update that applies to this memory error.
  3. Make sure that the DIMMs are firmly seated and no foreign material is found in the DIMM connector. Then, retry with the same DIMM.
  4. If the problem is related to a DIMM, replace the failing DIMM indicated by the error LEDs.
  5. If the problem occurs on the same DIMM connector, swap the affected DIMMs (as indicated by the error LEDs on the system board or the event logs) to a different memory channel or microprocessor.
  6. (Trained technician only) If the problem occurs on the same DIMM connector, check the DIMM connector. If the connector contains any foreign material or is damaged, replace the system board.
  7. (Trained service technician only) Remove the affected microprocessor and check the microprocessor socket pins for any damaged pins. If a damage is found, replace the system board.
  8. (Trained service technician only) If the problem is related to microprocessor socket pins, replace the system board.
- **806f030c-2581ffff : Scrub Failure for [PhysicalMemoryElementName] on Subsystem [MemoryElementName]. (All DIMMS)**

This message is for the use case when an implementation has detected a Memory Scrub failure.

May also be shown as 806f030c2581ffff or 0x806f030c2581ffff

**Severity**

Error

**Serviceable**

Yes

**Automatically notify support**

No

**Alert Category**

Critical - Memory

**SNMP Trap ID**

41

**CIM Information**

**Prefix:** PLAT ID: 0136

**User Response**

Note: Each time you install or remove a DIMM, you must disconnect the server from the power source; then, wait 10 seconds before restarting the server.

1. Refer to TIP H212293 for minimum code level.

2. Check the Lenovo support website for an applicable retain tip or firmware update that applies to this memory error.
3. Make sure that the DIMMs are firmly seated and no foreign material is found in the DIMM connector. Then, retry with the same DIMM.
4. If the problem is related to a DIMM, replace the failing DIMM indicated by the error LEDs.
5. If the problem occurs on the same DIMM connector, swap the affected DIMMs (as indicated by the error LEDs on the system board or the event logs) to a different memory channel or microprocessor.
6. (Trained technician only) If the problem occurs on the same DIMM connector, check the DIMM connector. If the connector contains any foreign material or is damaged, replace the system board.
7. (Trained service technician only) Remove the affected microprocessor and check the microprocessor socket pins for any damaged pins. If a damage is found, replace the system board.
8. (Trained service technician only) If the problem is related to microprocessor socket pins, replace the system board.

One of the DIMMs :

- **806f030d-0400ffff : Hot Spare enabled for [ComputerSystemElementName]. (Drive 0)**

This message is for the use case when an implementation has detected a Hot Spare has been Enabled.

May also be shown as 806f030d0400ffff or 0x806f030d0400ffff

**Severity**

Info

**Serviceable**

No

**Automatically notify support**

No

**Alert Category**

System - Other

**SNMP Trap ID**

**CIM Information**

**Prefix:** PLAT ID: 0170

**User Response**

No action; information only.

- **806f030d-0401ffff : Hot Spare enabled for [ComputerSystemElementName]. (Drive 1)**

This message is for the use case when an implementation has detected a Hot Spare has been Enabled.

May also be shown as 806f030d0401ffff or 0x806f030d0401ffff

**Severity**

Info

**Serviceable**

No

**Automatically notify support**

No

**Alert Category**

System - Other

**SNMP Trap ID**

**CIM Information**

**Prefix:** PLAT ID: 0170

**User Response**

No action; information only.

- **806f030d-0402ffff : Hot Spare enabled for [ComputerSystemElementName]. (Drive 2)**

This message is for the use case when an implementation has detected a Hot Spare has been Enabled.

May also be shown as 806f030d0402ffff or 0x806f030d0402ffff

**Severity**

Info

**Serviceable**

No

**Automatically notify support**

No

**Alert Category**

System - Other

**SNMP Trap ID**

**CIM Information**

**Prefix:** PLAT ID: 0170

**User Response**

No action; information only.

- **806f030d-0403ffff : Hot Spare enabled for [ComputerSystemElementName]. (Drive 3)**

This message is for the use case when an implementation has detected a Hot Spare has been Enabled.

May also be shown as 806f030d0403ffff or 0x806f030d0403ffff

**Severity**

Info

**Serviceable**

No

**Automatically notify support**

No

**Alert Category**

System - Other

**SNMP Trap ID**

**CIM Information**

**Prefix:** PLAT ID: 0170

**User Response**

No action; information only.

- **806f030d-0404ffff : Hot Spare enabled for [ComputerSystemElementName]. (Drive 4)**

This message is for the use case when an implementation has detected a Hot Spare has been Enabled.

May also be shown as 806f030d0404ffff or 0x806f030d0404ffff

**Severity**

Info

**Serviceable**

No

**Automatically notify support**

No

**Alert Category**

System - Other

**SNMP Trap ID**

**CIM Information**

Prefix: PLAT ID: 0170

**User Response**

No action; information only.

- **806f030d-0405ffff : Hot Spare enabled for [ComputerSystemElementName]. (Drive 5)**

This message is for the use case when an implementation has detected a Hot Spare has been Enabled.

May also be shown as 806f030d0405ffff or 0x806f030d0405ffff

**Severity**

Info

**Serviceable**

No

**Automatically notify support**

No

**Alert Category**

System - Other

**SNMP Trap ID**

**CIM Information**

Prefix: PLAT ID: 0170

**User Response**

No action; information only.

- **806f030d-0406ffff : Hot Spare enabled for [ComputerSystemElementName]. (Drive 6)**

This message is for the use case when an implementation has detected a Hot Spare has been Enabled.

May also be shown as 806f030d0406ffff or 0x806f030d0406ffff

**Severity**

Info

**Serviceable**

No

**Automatically notify support**

No

**Alert Category**

System - Other

## SNMP Trap ID

### CIM Information

Prefix: PLAT ID: 0170

### User Response

No action; information only.

- **806f030d-0407ffff : Hot Spare enabled for [ComputerSystemElementName]. (Drive 7)**

This message is for the use case when an implementation has detected a Hot Spare has been Enabled.

May also be shown as 806f030d0407ffff or 0x806f030d0407ffff

### Severity

Info

### Serviceable

No

### Automatically notify support

No

### Alert Category

System - Other

## SNMP Trap ID

### CIM Information

Prefix: PLAT ID: 0170

### User Response

No action; information only.

- **806f030d-0408ffff : Hot Spare enabled for [ComputerSystemElementName]. (Drive 8)**

This message is for the use case when an implementation has detected a Hot Spare has been Enabled.

May also be shown as 806f030d0408ffff or 0x806f030d0408ffff

### Severity

Info

### Serviceable

No

### Automatically notify support

No

### Alert Category

System - Other

## SNMP Trap ID

### CIM Information

Prefix: PLAT ID: 0170

### User Response

No action; information only.

- **806f030d-0409ffff : Hot Spare enabled for [ComputerSystemElementName]. (Drive 9)**

This message is for the use case when an implementation has detected a Hot Spare has been Enabled.

May also be shown as 806f030d0409ffff or 0x806f030d0409ffff

**Severity**

Info

**Serviceable**

No

**Automatically notify support**

No

**Alert Category**

System - Other

**SNMP Trap ID****CIM Information**

Prefix: PLAT ID: 0170

**User Response**

No action; information only.

- **806f030d-040affff : Hot Spare enabled for [ComputerSystemElementName]. (Drive 10)**

This message is for the use case when an implementation has detected a Hot Spare has been Enabled.

May also be shown as 806f030d040affff or 0x806f030d040affff

**Severity**

Info

**Serviceable**

No

**Automatically notify support**

No

**Alert Category**

System - Other

**SNMP Trap ID****CIM Information**

Prefix: PLAT ID: 0170

**User Response**

No action; information only.

- **806f030d-040bffff : Hot Spare enabled for [ComputerSystemElementName]. (Drive 11)**

This message is for the use case when an implementation has detected a Hot Spare has been Enabled.

May also be shown as 806f030d040bffff or 0x806f030d040bffff

**Severity**

Info

**Serviceable**

No

**Automatically notify support**

No

**Alert Category**

System - Other

**SNMP Trap ID**



**CIM Information**

Prefix: PLAT ID: 0170

**User Response**

No action; information only.

- **806f030d-040cffff : Hot Spare enabled for [ComputerSystemElementName]. (Drive 12)**

This message is for the use case when an implementation has detected a Hot Spare has been Enabled.

May also be shown as 806f030d040cffff or 0x806f030d040cffff

**Severity**

Info

**Serviceable**

No

**Automatically notify support**

No

**Alert Category**

System - Other

**SNMP Trap ID****CIM Information**

Prefix: PLAT ID: 0170

**User Response**

No action; information only.

- **806f030d-040dffff : Hot Spare enabled for [ComputerSystemElementName]. (Drive 13)**

This message is for the use case when an implementation has detected a Hot Spare has been Enabled.

May also be shown as 806f030d040dffff or 0x806f030d040dffff

**Severity**

Info

**Serviceable**

No

**Automatically notify support**

No

**Alert Category**

System - Other

**SNMP Trap ID****CIM Information**

Prefix: PLAT ID: 0170

**User Response**

No action; information only.

- **806f030d-040effff : Hot Spare enabled for [ComputerSystemElementName]. (Drive 14)**

This message is for the use case when an implementation has detected a Hot Spare has been Enabled.

May also be shown as 806f030d040effff or 0x806f030d040effff

**Severity**

Info

**Serviceable**

No

**Automatically notify support**

No

**Alert Category**

System - Other

**SNMP Trap ID****CIM Information**

Prefix: PLAT ID: 0170

**User Response**

No action; information only.

- **806f030d-040ffff : Hot Spare enabled for [ComputerSystemElementName]. (Drive 15)**

This message is for the use case when an implementation has detected a Hot Spare has been Enabled.

May also be shown as 806f030d040ffff or 0x806f030d040ffff

**Severity**

Info

**Serviceable**

No

**Automatically notify support**

No

**Alert Category**

System - Other

**SNMP Trap ID****CIM Information**

Prefix: PLAT ID: 0170

**User Response**

No action; information only.

- **806f030d-0410ffff : Hot Spare enabled for [ComputerSystemElementName]. (Drive 16)**

This message is for the use case when an implementation has detected a Hot Spare has been Enabled.

May also be shown as 806f030d0410ffff or 0x806f030d0410ffff

**Severity**

Info

**Serviceable**

No

**Automatically notify support**

No

**Alert Category**

System - Other

**SNMP Trap ID****CIM Information**

Prefix: PLAT ID: 0170

**User Response**

No action; information only.

- **806f030d-0411ffff : Hot Spare enabled for [ComputerSystemElementName]. (Drive 17)**

This message is for the use case when an implementation has detected a Hot Spare has been Enabled.

May also be shown as 806f030d0411ffff or 0x806f030d0411ffff

**Severity**

Info

**Serviceable**

No

**Automatically notify support**

No

**Alert Category**

System - Other

**SNMP Trap ID****CIM Information**

Prefix: PLAT ID: 0170

**User Response**

No action; information only.

- **806f030d-0412ffff : Hot Spare enabled for [ComputerSystemElementName]. (Drive 18)**

This message is for the use case when an implementation has detected a Hot Spare has been Enabled.

May also be shown as 806f030d0412ffff or 0x806f030d0412ffff

**Severity**

Info

**Serviceable**

No

**Automatically notify support**

No

**Alert Category**

System - Other

**SNMP Trap ID****CIM Information**

Prefix: PLAT ID: 0170

**User Response**

No action; information only.

- **806f030d-0413ffff : Hot Spare enabled for [ComputerSystemElementName]. (Drive 19)**

This message is for the use case when an implementation has detected a Hot Spare has been Enabled.

May also be shown as 806f030d0413ffff or 0x806f030d0413ffff

**Severity**

Info

**Serviceable**

No

**Automatically notify support**

No

**Alert Category**

System - Other

**SNMP Trap ID****CIM Information**

Prefix: PLAT ID: 0170

**User Response**

No action; information only.

- **806f030d-0414ffff : Hot Spare enabled for [ComputerSystemElementName]. (Drive 20)**

This message is for the use case when an implementation has detected a Hot Spare has been Enabled.

May also be shown as 806f030d0414ffff or 0x806f030d0414ffff

**Severity**

Info

**Serviceable**

No

**Automatically notify support**

No

**Alert Category**

System - Other

**SNMP Trap ID****CIM Information**

Prefix: PLAT ID: 0170

**User Response**

No action; information only.

- **806f030d-0415ffff : Hot Spare enabled for [ComputerSystemElementName]. (Drive 21)**

This message is for the use case when an implementation has detected a Hot Spare has been Enabled.

May also be shown as 806f030d0415ffff or 0x806f030d0415ffff

**Severity**

Info

**Serviceable**

No

**Automatically notify support**

No

**Alert Category**

System - Other

**SNMP Trap ID****CIM Information**

Prefix: PLAT ID: 0170

**User Response**

No action; information only.

- **806f030d-0416ffff : Hot Spare enabled for [ComputerSystemElementName]. (Drive 22)**

This message is for the use case when an implementation has detected a Hot Spare has been Enabled.

May also be shown as 806f030d0416ffff or 0x806f030d0416ffff

**Severity**

Info

**Serviceable**

No

**Automatically notify support**

No

**Alert Category**

System - Other

**SNMP Trap ID**

**CIM Information**

Prefix: PLAT ID: 0170

**User Response**

No action; information only.

- **806f030d-0417ffff : Hot Spare enabled for [ComputerSystemElementName]. (Drive 23)**

This message is for the use case when an implementation has detected a Hot Spare has been Enabled.

May also be shown as 806f030d0417ffff or 0x806f030d0417ffff

**Severity**

Info

**Serviceable**

No

**Automatically notify support**

No

**Alert Category**

System - Other

**SNMP Trap ID**

**CIM Information**

Prefix: PLAT ID: 0170

**User Response**

No action; information only.

- **806f030d-0418ffff : Hot Spare enabled for [ComputerSystemElementName]. (Drive 24)**

This message is for the use case when an implementation has detected a Hot Spare has been Enabled.

May also be shown as 806f030d0418ffff or 0x806f030d0418ffff

**Severity**

Info

**Serviceable**

No

**Automatically notify support**

No

**Alert Category**

System - Other

**SNMP Trap ID**

**CIM Information**

Prefix: PLAT ID: 0170

**User Response**

No action; information only.

- **806f030d-0419ffff : Hot Spare enabled for [ComputerSystemElementName]. (Drive 25)**

This message is for the use case when an implementation has detected a Hot Spare has been Enabled.

May also be shown as 806f030d0419ffff or 0x806f030d0419ffff

**Severity**

Info

**Serviceable**

No

**Automatically notify support**

No

**Alert Category**

System - Other

**SNMP Trap ID**

**CIM Information**

Prefix: PLAT ID: 0170

**User Response**

No action; information only.

- **806f030d-041affff : Hot Spare enabled for [ComputerSystemElementName]. (Drive 26)**

This message is for the use case when an implementation has detected a Hot Spare has been Enabled.

May also be shown as 806f030d041affff or 0x806f030d041affff

**Severity**

Info

**Serviceable**

No

**Automatically notify support**

No

**Alert Category**

System - Other

**SNMP Trap ID**

**CIM Information**

Prefix: PLAT ID: 0170

**User Response**

No action; information only.

- **806f030d-041bffff : Hot Spare enabled for [ComputerSystemElementName]. (Drive 27)**

This message is for the use case when an implementation has detected a Hot Spare has been Enabled.  
May also be shown as 806f030d041bffff or 0x806f030d041bffff

**Severity**

Info

**Serviceable**

No

**Automatically notify support**

No

**Alert Category**

System - Other

**SNMP Trap ID**

**CIM Information**

Prefix: PLAT ID: 0170

**User Response**

No action; information only.

- **806f030d-041cffff : Hot Spare enabled for [ComputerSystemElementName]. (Drive 28)**

This message is for the use case when an implementation has detected a Hot Spare has been Enabled.  
May also be shown as 806f030d041cffff or 0x806f030d041cffff

**Severity**

Info

**Serviceable**

No

**Automatically notify support**

No

**Alert Category**

System - Other

**SNMP Trap ID**

**CIM Information**

Prefix: PLAT ID: 0170

**User Response**

No action; information only.

- **806f030d-041dffff : Hot Spare enabled for [ComputerSystemElementName]. (Drive 29)**

This message is for the use case when an implementation has detected a Hot Spare has been Enabled.  
May also be shown as 806f030d041dffff or 0x806f030d041dffff

**Severity**

Info

**Serviceable**

No

**Automatically notify support**

No

**Alert Category**  
System - Other

**SNMP Trap ID**

**CIM Information**  
Prefix: PLAT ID: 0170

**User Response**  
No action; information only.

- **806f030d-041effff : Hot Spare enabled for [ComputerSystemElementName]. (Drive 30)**

This message is for the use case when an implementation has detected a Hot Spare has been Enabled.  
May also be shown as 806f030d041effff or 0x806f030d041effff

**Severity**  
Info

**Serviceable**  
No

**Automatically notify support**  
No

**Alert Category**  
System - Other

**SNMP Trap ID**

**CIM Information**  
Prefix: PLAT ID: 0170

**User Response**  
No action; information only.

- **806f030d-041fffff : Hot Spare enabled for [ComputerSystemElementName]. (Drive 31)**

This message is for the use case when an implementation has detected a Hot Spare has been Enabled.  
May also be shown as 806f030d041fffff or 0x806f030d041fffff

**Severity**  
Info

**Serviceable**  
No

**Automatically notify support**  
No

**Alert Category**  
System - Other

**SNMP Trap ID**

**CIM Information**  
Prefix: PLAT ID: 0170

**User Response**  
No action; information only.

- **806f030d-0420ffff : Hot Spare enabled for [ComputerSystemElementName]. (Ext Drive)**

This message is for the use case when an implementation has detected a Hot Spare has been Enabled.



May also be shown as 806f030d0420ffff or 0x806f030d0420ffff

**Severity**

Info

**Serviceable**

No

**Automatically notify support**

No

**Alert Category**

System - Other

**SNMP Trap ID**

**CIM Information**

**Prefix: PLAT ID:** 0170

**User Response**

No action; information only.

- **806f0313-1701ffff : A software NMI has occurred on system [ComputerSystemElementName]. (NMI State)**

This message is for the use case when an implementation has detected a Software NMI.

May also be shown as 806f03131701ffff or 0x806f03131701ffff

**Severity**

Error

**Serviceable**

Yes

**Automatically notify support**

No

**Alert Category**

Critical - Other

**SNMP Trap ID**

50

**CIM Information**

**Prefix: PLAT ID:** 0228

**User Response**

1. Check the device driver.
2. Reinstall the device driver.
3. Update all device drivers to the latest level.
4. Update the firmware (UEFI and IMM).

- **806f0323-2101ffff : Power cycle of system [ComputerSystemElementName] initiated by watchdog [WatchdogElementName]. (IPMI Watchdog)**

This message is for the use case when an implementation has detected a Power Cycle by Watchdog occurred.

May also be shown as 806f03232101ffff or 0x806f03232101ffff

**Severity**

Info

**Serviceable**

No

**Automatically notify support**

No

**Alert Category**

System - Other

**SNMP Trap ID****CIM Information**

Prefix: PLAT ID: 0374

**User Response**

No action; information only.

- **806f040c-2001ffff : [PhysicalMemoryElementName] Disabled on Subsystem [MemoryElementName]. (DIMM 1)**

This message is for the use case when an implementation has detected that Memory has been Disabled.

May also be shown as 806f040c2001ffff or 0x806f040c2001ffff

**Severity**

Info

**Serviceable**

No

**Automatically notify support**

No

**Alert Category**

System - Other

**SNMP Trap ID****CIM Information**

Prefix: PLAT ID: 0131

**User Response**

1. Make sure the DIMM is installed correctly.
2. If the DIMM was disabled because of a memory fault (memory uncorrectable error or memory logging limit reached), follow the suggested actions for that error event and restart the server.
3. Check the Lenovo support website for an applicable retain tip or firmware update that applies to this memory event. If no memory fault is recorded in the logs and no DIMM connector error LED is lit, you can re-enable the DIMM through the Setup utility or the ToolsCenter Suite CLI.

- **806f040c-2002ffff : [PhysicalMemoryElementName] Disabled on Subsystem [MemoryElementName]. (DIMM 2)**

This message is for the use case when an implementation has detected that Memory has been Disabled.

May also be shown as 806f040c2002ffff or 0x806f040c2002ffff

**Severity**

Info

**Serviceable**

No

**Automatically notify support**

No

**Alert Category**

System - Other

**SNMP Trap ID**

**CIM Information**

Prefix: PLAT ID: 0131

**User Response**

1. Make sure the DIMM is installed correctly.
  2. If the DIMM was disabled because of a memory fault (memory uncorrectable error or memory logging limit reached), follow the suggested actions for that error event and restart the server.
  3. Check the Lenovo support website for an applicable retain tip or firmware update that applies to this memory event. If no memory fault is recorded in the logs and no DIMM connector error LED is lit, you can re-enable the DIMM through the Setup utility or the ToolsCenter Suite CLI.
- **806f040c-2003ffff : [PhysicalMemoryElementName] Disabled on Subsystem [MemoryElementName]. (DIMM 3)**

This message is for the use case when an implementation has detected that Memory has been Disabled. May also be shown as 806f040c2003ffff or 0x806f040c2003ffff

**Severity**

Info

**Serviceable**

No

**Automatically notify support**

No

**Alert Category**

System - Other

**SNMP Trap ID**

**CIM Information**

Prefix: PLAT ID: 0131

**User Response**

1. Make sure the DIMM is installed correctly.
  2. If the DIMM was disabled because of a memory fault (memory uncorrectable error or memory logging limit reached), follow the suggested actions for that error event and restart the server.
  3. Check the Lenovo support website for an applicable retain tip or firmware update that applies to this memory event. If no memory fault is recorded in the logs and no DIMM connector error LED is lit, you can re-enable the DIMM through the Setup utility or the ToolsCenter Suite CLI.
- **806f040c-2004ffff : [PhysicalMemoryElementName] Disabled on Subsystem [MemoryElementName]. (DIMM 4)**

This message is for the use case when an implementation has detected that Memory has been Disabled. May also be shown as 806f040c2004ffff or 0x806f040c2004ffff

**Severity**

Info

**Serviceable**

No

**Automatically notify support**

No

**Alert Category**

System - Other

**SNMP Trap ID**

**CIM Information**

Prefix: PLAT ID: 0131

**User Response**

1. Make sure the DIMM is installed correctly.
  2. If the DIMM was disabled because of a memory fault (memory uncorrectable error or memory logging limit reached), follow the suggested actions for that error event and restart the server.
  3. Check the Lenovo support website for an applicable retain tip or firmware update that applies to this memory event. If no memory fault is recorded in the logs and no DIMM connector error LED is lit, you can re-enable the DIMM through the Setup utility or the ToolsCenter Suite CLI.
- **806f040c-2005ffff : [PhysicalMemoryElementName] Disabled on Subsystem [MemoryElementName]. (DIMM 5)**

This message is for the use case when an implementation has detected that Memory has been Disabled.

May also be shown as 806f040c2005ffff or 0x806f040c2005ffff

**Severity**

Info

**Serviceable**

No

**Automatically notify support**

No

**Alert Category**

System - Other

**SNMP Trap ID**

**CIM Information**

Prefix: PLAT ID: 0131

**User Response**

1. Make sure the DIMM is installed correctly.
  2. If the DIMM was disabled because of a memory fault (memory uncorrectable error or memory logging limit reached), follow the suggested actions for that error event and restart the server.
  3. Check the Lenovo support website for an applicable retain tip or firmware update that applies to this memory event. If no memory fault is recorded in the logs and no DIMM connector error LED is lit, you can re-enable the DIMM through the Setup utility or the ToolsCenter Suite CLI.
- **806f040c-2006ffff : [PhysicalMemoryElementName] Disabled on Subsystem [MemoryElementName]. (DIMM 6)**

This message is for the use case when an implementation has detected that Memory has been Disabled.

May also be shown as 806f040c2006ffff or 0x806f040c2006ffff

**Severity**

Info

**Serviceable**

No

**Automatically notify support**

No

**Alert Category**

System - Other

**SNMP Trap ID**

**CIM Information**

**Prefix:** PLAT ID: 0131

**User Response**

1. Make sure the DIMM is installed correctly.
  2. If the DIMM was disabled because of a memory fault (memory uncorrectable error or memory logging limit reached), follow the suggested actions for that error event and restart the server.
  3. Check the Lenovo support website for an applicable retain tip or firmware update that applies to this memory event. If no memory fault is recorded in the logs and no DIMM connector error LED is lit, you can re-enable the DIMM through the Setup utility or the ToolsCenter Suite CLI.
- **806f040c-2007ffff : [PhysicalMemoryElementName] Disabled on Subsystem [MemoryElementName]. (DIMM 7)**

This message is for the use case when an implementation has detected that Memory has been Disabled. May also be shown as 806f040c2007ffff or 0x806f040c2007ffff

**Severity**

Info

**Serviceable**

No

**Automatically notify support**

No

**Alert Category**

System - Other

**SNMP Trap ID**

**CIM Information**

**Prefix:** PLAT ID: 0131

**User Response**

1. Make sure the DIMM is installed correctly.
  2. If the DIMM was disabled because of a memory fault (memory uncorrectable error or memory logging limit reached), follow the suggested actions for that error event and restart the server.
  3. Check the Lenovo support website for an applicable retain tip or firmware update that applies to this memory event. If no memory fault is recorded in the logs and no DIMM connector error LED is lit, you can re-enable the DIMM through the Setup utility or the ToolsCenter Suite CLI.
- **806f040c-2008ffff : [PhysicalMemoryElementName] Disabled on Subsystem [MemoryElementName]. (DIMM 8)**

This message is for the use case when an implementation has detected that Memory has been Disabled.

May also be shown as 806f040c2008ffff or 0x806f040c2008ffff

**Severity**

Info

**Serviceable**

No

**Automatically notify support**

No

**Alert Category**

System - Other

**SNMP Trap ID**

**CIM Information**

**Prefix: PLAT ID:** 0131

**User Response**

1. Make sure the DIMM is installed correctly.
  2. If the DIMM was disabled because of a memory fault (memory uncorrectable error or memory logging limit reached), follow the suggested actions for that error event and restart the server.
  3. Check the Lenovo support website for an applicable retain tip or firmware update that applies to this memory event. If no memory fault is recorded in the logs and no DIMM connector error LED is lit, you can re-enable the DIMM through the Setup utility or the ToolsCenter Suite CLI.
- **806f040c-2009ffff : [PhysicalMemoryElementName] Disabled on Subsystem [MemoryElementName]. (DIMM 9)**

This message is for the use case when an implementation has detected that Memory has been Disabled.

May also be shown as 806f040c2009ffff or 0x806f040c2009ffff

**Severity**

Info

**Serviceable**

No

**Automatically notify support**

No

**Alert Category**

System - Other

**SNMP Trap ID**

**CIM Information**

**Prefix: PLAT ID:** 0131

**User Response**

1. Make sure the DIMM is installed correctly.
2. If the DIMM was disabled because of a memory fault (memory uncorrectable error or memory logging limit reached), follow the suggested actions for that error event and restart the server.
3. Check the Lenovo support website for an applicable retain tip or firmware update that applies to this memory event. If no memory fault is recorded in the logs and no DIMM connector error LED is lit, you can re-enable the DIMM through the Setup utility or the ToolsCenter Suite CLI.

- **806f040c-200afff : [PhysicalMemoryElementName] Disabled on Subsystem [MemoryElementName]. (DIMM 10)**

This message is for the use case when an implementation has detected that Memory has been Disabled.  
May also be shown as 806f040c200afff or 0x806f040c200afff

**Severity**

Info

**Serviceable**

No

**Automatically notify support**

No

**Alert Category**

System - Other

**SNMP Trap ID**

**CIM Information**

Prefix: PLAT ID: 0131

**User Response**

1. Make sure the DIMM is installed correctly.
2. If the DIMM was disabled because of a memory fault (memory uncorrectable error or memory logging limit reached), follow the suggested actions for that error event and restart the server.
3. Check the Lenovo support website for an applicable retain tip or firmware update that applies to this memory event. If no memory fault is recorded in the logs and no DIMM connector error LED is lit, you can re-enable the DIMM through the Setup utility or the ToolsCenter Suite CLI.

- **806f040c-200bfff : [PhysicalMemoryElementName] Disabled on Subsystem [MemoryElementName]. (DIMM 11)**

This message is for the use case when an implementation has detected that Memory has been Disabled.  
May also be shown as 806f040c200bfff or 0x806f040c200bfff

**Severity**

Info

**Serviceable**

No

**Automatically notify support**

No

**Alert Category**

System - Other

**SNMP Trap ID**

**CIM Information**

Prefix: PLAT ID: 0131

**User Response**

1. Make sure the DIMM is installed correctly.
2. If the DIMM was disabled because of a memory fault (memory uncorrectable error or memory logging limit reached), follow the suggested actions for that error event and restart the server.

3. Check the Lenovo support website for an applicable retain tip or firmware update that applies to this memory event. If no memory fault is recorded in the logs and no DIMM connector error LED is lit, you can re-enable the DIMM through the Setup utility or the ToolsCenter Suite CLI.

- **806f040c-200cffff : [PhysicalMemoryElementName] Disabled on Subsystem [MemoryElementName]. (DIMM 12)**

This message is for the use case when an implementation has detected that Memory has been Disabled.

May also be shown as 806f040c200cffff or 0x806f040c200cffff

**Severity**

Info

**Serviceable**

No

**Automatically notify support**

No

**Alert Category**

System - Other

**SNMP Trap ID**

**CIM Information**

Prefix: PLAT ID: 0131

**User Response**

1. Make sure the DIMM is installed correctly.
2. If the DIMM was disabled because of a memory fault (memory uncorrectable error or memory logging limit reached), follow the suggested actions for that error event and restart the server.
3. Check the Lenovo support website for an applicable retain tip or firmware update that applies to this memory event. If no memory fault is recorded in the logs and no DIMM connector error LED is lit, you can re-enable the DIMM through the Setup utility or the ToolsCenter Suite CLI.

- **806f040c-200dffff : [PhysicalMemoryElementName] Disabled on Subsystem [MemoryElementName]. (DIMM 13)**

This message is for the use case when an implementation has detected that Memory has been Disabled.

May also be shown as 806f040c200dffff or 0x806f040c200dffff

**Severity**

Info

**Serviceable**

No

**Automatically notify support**

No

**Alert Category**

System - Other

**SNMP Trap ID**

**CIM Information**

Prefix: PLAT ID: 0131

**User Response**

1. Make sure the DIMM is installed correctly.



2. If the DIMM was disabled because of a memory fault (memory uncorrectable error or memory logging limit reached), follow the suggested actions for that error event and restart the server.
  3. Check the Lenovo support website for an applicable retain tip or firmware update that applies to this memory event. If no memory fault is recorded in the logs and no DIMM connector error LED is lit, you can re-enable the DIMM through the Setup utility or the ToolsCenter Suite CLI.
- **806f040c-200effff : [PhysicalMemoryElementName] Disabled on Subsystem [MemoryElementName]. (DIMM 14)**

This message is for the use case when an implementation has detected that Memory has been Disabled. May also be shown as 806f040c200effff or 0x806f040c200effff

**Severity**

Info

**Serviceable**

No

**Automatically notify support**

No

**Alert Category**

System - Other

**SNMP Trap ID**

**CIM Information**

Prefix: PLAT ID: 0131

**User Response**

1. Make sure the DIMM is installed correctly.
  2. If the DIMM was disabled because of a memory fault (memory uncorrectable error or memory logging limit reached), follow the suggested actions for that error event and restart the server.
  3. Check the Lenovo support website for an applicable retain tip or firmware update that applies to this memory event. If no memory fault is recorded in the logs and no DIMM connector error LED is lit, you can re-enable the DIMM through the Setup utility or the ToolsCenter Suite CLI.
- **806f040c-200fffff : [PhysicalMemoryElementName] Disabled on Subsystem [MemoryElementName]. (DIMM 15)**

This message is for the use case when an implementation has detected that Memory has been Disabled. May also be shown as 806f040c200fffff or 0x806f040c200fffff

**Severity**

Info

**Serviceable**

No

**Automatically notify support**

No

**Alert Category**

System - Other

**SNMP Trap ID**

**CIM Information**

Prefix: PLAT ID: 0131

### User Response

1. Make sure the DIMM is installed correctly.
  2. If the DIMM was disabled because of a memory fault (memory uncorrectable error or memory logging limit reached), follow the suggested actions for that error event and restart the server.
  3. Check the Lenovo support website for an applicable retain tip or firmware update that applies to this memory event. If no memory fault is recorded in the logs and no DIMM connector error LED is lit, you can re-enable the DIMM through the Setup utility or the ToolsCenter Suite CLI.
- **806f040c-2010ffff : [PhysicalMemoryElementName] Disabled on Subsystem [MemoryElementName]. (DIMM 16)**

This message is for the use case when an implementation has detected that Memory has been Disabled. May also be shown as 806f040c2010ffff or 0x806f040c2010ffff

### Severity

Info

### Serviceable

No

### Automatically notify support

No

### Alert Category

System - Other

### SNMP Trap ID

### CIM Information

Prefix: PLAT ID: 0131

### User Response

1. Make sure the DIMM is installed correctly.
  2. If the DIMM was disabled because of a memory fault (memory uncorrectable error or memory logging limit reached), follow the suggested actions for that error event and restart the server.
  3. Check the Lenovo support website for an applicable retain tip or firmware update that applies to this memory event. If no memory fault is recorded in the logs and no DIMM connector error LED is lit, you can re-enable the DIMM through the Setup utility or the ToolsCenter Suite CLI.
- **806f040c-2011ffff : [PhysicalMemoryElementName] Disabled on Subsystem [MemoryElementName]. (DIMM 17)**

This message is for the use case when an implementation has detected that Memory has been Disabled. May also be shown as 806f040c2011ffff or 0x806f040c2011ffff

### Severity

Info

### Serviceable

No

### Automatically notify support

No

### Alert Category

System - Other

### SNMP Trap ID

**CIM Information**

Prefix: PLAT ID: 0131

**User Response**

1. Make sure the DIMM is installed correctly.
  2. If the DIMM was disabled because of a memory fault (memory uncorrectable error or memory logging limit reached), follow the suggested actions for that error event and restart the server.
  3. Check the Lenovo support website for an applicable retain tip or firmware update that applies to this memory event. If no memory fault is recorded in the logs and no DIMM connector error LED is lit, you can re-enable the DIMM through the Setup utility or the ToolsCenter Suite CLI.
- **806f040c-2012ffff : [PhysicalMemoryElementName] Disabled on Subsystem [MemoryElementName]. (DIMM 18)**

This message is for the use case when an implementation has detected that Memory has been Disabled.

May also be shown as 806f040c2012ffff or 0x806f040c2012ffff

**Severity**

Info

**Serviceable**

No

**Automatically notify support**

No

**Alert Category**

System - Other

**SNMP Trap ID****CIM Information**

Prefix: PLAT ID: 0131

**User Response**

1. Make sure the DIMM is installed correctly.
  2. If the DIMM was disabled because of a memory fault (memory uncorrectable error or memory logging limit reached), follow the suggested actions for that error event and restart the server.
  3. Check the Lenovo support website for an applicable retain tip or firmware update that applies to this memory event. If no memory fault is recorded in the logs and no DIMM connector error LED is lit, you can re-enable the DIMM through the Setup utility or the ToolsCenter Suite CLI.
- **806f040c-2013ffff : [PhysicalMemoryElementName] Disabled on Subsystem [MemoryElementName]. (DIMM 19)**

This message is for the use case when an implementation has detected that Memory has been Disabled.

May also be shown as 806f040c2013ffff or 0x806f040c2013ffff

**Severity**

Info

**Serviceable**

No

**Automatically notify support**

No

**Alert Category**

System - Other

## SNMP Trap ID

### CIM Information

Prefix: PLAT ID: 0131

### User Response

1. Make sure the DIMM is installed correctly.
  2. If the DIMM was disabled because of a memory fault (memory uncorrectable error or memory logging limit reached), follow the suggested actions for that error event and restart the server.
  3. Check the Lenovo support website for an applicable retain tip or firmware update that applies to this memory event. If no memory fault is recorded in the logs and no DIMM connector error LED is lit, you can re-enable the DIMM through the Setup utility or the ToolsCenter Suite CLI.
- **806f040c-2014ffff : [PhysicalMemoryElementName] Disabled on Subsystem [MemoryElementName]. (DIMM 20)**

This message is for the use case when an implementation has detected that Memory has been Disabled.

May also be shown as 806f040c2014ffff or 0x806f040c2014ffff

### Severity

Info

### Serviceable

No

### Automatically notify support

No

### Alert Category

System - Other

## SNMP Trap ID

### CIM Information

Prefix: PLAT ID: 0131

### User Response

1. Make sure the DIMM is installed correctly.
  2. If the DIMM was disabled because of a memory fault (memory uncorrectable error or memory logging limit reached), follow the suggested actions for that error event and restart the server.
  3. Check the Lenovo support website for an applicable retain tip or firmware update that applies to this memory event. If no memory fault is recorded in the logs and no DIMM connector error LED is lit, you can re-enable the DIMM through the Setup utility or the ToolsCenter Suite CLI.
- **806f040c-2015ffff : [PhysicalMemoryElementName] Disabled on Subsystem [MemoryElementName]. (DIMM 21)**

This message is for the use case when an implementation has detected that Memory has been Disabled.

May also be shown as 806f040c2015ffff or 0x806f040c2015ffff

### Severity

Info

### Serviceable

No

### Automatically notify support

No

**Alert Category**

System - Other

**SNMP Trap ID****CIM Information**

Prefix: PLAT ID: 0131

**User Response**

1. Make sure the DIMM is installed correctly.
  2. If the DIMM was disabled because of a memory fault (memory uncorrectable error or memory logging limit reached), follow the suggested actions for that error event and restart the server.
  3. Check the Lenovo support website for an applicable retain tip or firmware update that applies to this memory event. If no memory fault is recorded in the logs and no DIMM connector error LED is lit, you can re-enable the DIMM through the Setup utility or the ToolsCenter Suite CLI.
- **806f040c-2016ffff : [PhysicalMemoryElementName] Disabled on Subsystem [MemoryElementName]. (DIMM 22)**

This message is for the use case when an implementation has detected that Memory has been Disabled.

May also be shown as 806f040c2016ffff or 0x806f040c2016ffff

**Severity**

Info

**Serviceable**

No

**Automatically notify support**

No

**Alert Category**

System - Other

**SNMP Trap ID****CIM Information**

Prefix: PLAT ID: 0131

**User Response**

1. Make sure the DIMM is installed correctly.
  2. If the DIMM was disabled because of a memory fault (memory uncorrectable error or memory logging limit reached), follow the suggested actions for that error event and restart the server.
  3. Check the Lenovo support website for an applicable retain tip or firmware update that applies to this memory event. If no memory fault is recorded in the logs and no DIMM connector error LED is lit, you can re-enable the DIMM through the Setup utility or the ToolsCenter Suite CLI.
- **806f040c-2017ffff : [PhysicalMemoryElementName] Disabled on Subsystem [MemoryElementName]. (DIMM 23)**

This message is for the use case when an implementation has detected that Memory has been Disabled.

May also be shown as 806f040c2017ffff or 0x806f040c2017ffff

**Severity**

Info

**Serviceable**

No

**Automatically notify support**

No

**Alert Category**

System - Other

**SNMP Trap ID****CIM Information**

Prefix: PLAT ID: 0131

**User Response**

1. Make sure the DIMM is installed correctly.
  2. If the DIMM was disabled because of a memory fault (memory uncorrectable error or memory logging limit reached), follow the suggested actions for that error event and restart the server.
  3. Check the Lenovo support website for an applicable retain tip or firmware update that applies to this memory event. If no memory fault is recorded in the logs and no DIMM connector error LED is lit, you can re-enable the DIMM through the Setup utility or the ToolsCenter Suite CLI.
- **806f040c-2018ffff : [PhysicalMemoryElementName] Disabled on Subsystem [MemoryElementName]. (DIMM 24)**

This message is for the use case when an implementation has detected that Memory has been Disabled.

May also be shown as 806f040c2018ffff or 0x806f040c2018ffff

**Severity**

Info

**Serviceable**

No

**Automatically notify support**

No

**Alert Category**

System - Other

**SNMP Trap ID****CIM Information**

Prefix: PLAT ID: 0131

**User Response**

1. Make sure the DIMM is installed correctly.
  2. If the DIMM was disabled because of a memory fault (memory uncorrectable error or memory logging limit reached), follow the suggested actions for that error event and restart the server.
  3. Check the Lenovo support website for an applicable retain tip or firmware update that applies to this memory event. If no memory fault is recorded in the logs and no DIMM connector error LED is lit, you can re-enable the DIMM through the Setup utility or the ToolsCenter Suite CLI.
- **806f040c-2581ffff : [PhysicalMemoryElementName] Disabled on Subsystem [MemoryElementName]. (All DIMMS)**

This message is for the use case when an implementation has detected that Memory has been Disabled.

May also be shown as 806f040c2581ffff or 0x806f040c2581ffff

**Severity**

Info

**Serviceable**

No

**Automatically notify support**

No

**Alert Category**

System - Other

**SNMP Trap ID****CIM Information****Prefix:** PLAT ID: 0131**User Response**

1. Make sure the DIMM is installed correctly.
2. If the DIMM was disabled because of a memory fault (memory uncorrectable error or memory logging limit reached), follow the suggested actions for that error event and restart the server.
3. Check the Lenovo support website for an applicable retain tip or firmware update that applies to this memory event. If no memory fault is recorded in the logs and no DIMM connector error LED is lit, you can re-enable the DIMM through the Setup utility or the ToolsCenter Suite CLI.

One of the DIMMs :

- **806f0413-2582ffff : A PCI PERR has occurred on system [ComputerSystemElementName]. (PCIs)**

This message is for the use case when an implementation has detected a PCI PERR.

May also be shown as 806f04132582ffff or 0x806f04132582ffff

**Severity**

Error

**Serviceable**

Yes

**Automatically notify support**

No

**Alert Category**

Critical - Other

**SNMP Trap ID**

50

**CIM Information****Prefix:** PLAT ID: 0232**User Response**

1. Check the PCI LED.
  2. Reseat the affected adapters and riser cards.
  3. Update the server firmware (UEFI and IMM) and adapter firmware. Important: Some cluster solutions require specific code levels or coordinated code updates. If the device is part of a cluster solution, verify that the latest level of code is supported for the cluster solution before you update the code.
  4. Remove both adapters.
  5. Replace the PCIe adapters.
  6. Replace the riser card.
- **806f0507-0301ffff : [ProcessorElementName] has a Configuration Mismatch. (CPU 1)**

This message is for the use case when an implementation has detected a Processor Configuration Mismatch has occurred.

May also be shown as 806f05070301ffff or 0x806f05070301ffff

**Severity**

Error

**Serviceable**

Yes

**Automatically notify support**

No

**Alert Category**

Critical - CPU

**SNMP Trap ID**

40

**CIM Information**

Prefix: PLAT ID: 0062

**User Response**

1. Check the CPU LED. See more information about the CPU LED in Light path diagnostics.
  2. Check for a server firmware update. Important: Some cluster solutions require specific code levels or coordinated code updates. If the device is part of a cluster solution, verify that the latest level of code is supported for the cluster solution before you update the code.
  3. Make sure that the installed microprocessors are compatible with each other.
  4. (Trained technician only) Reseat microprocessor n.
  5. (Trained technician only) Replace microprocessor n. (n = microprocessor number)
- **806f0507-0302ffff : [ProcessorElementName] has a Configuration Mismatch. (CPU 2)**

This message is for the use case when an implementation has detected a Processor Configuration Mismatch has occurred.

May also be shown as 806f05070302ffff or 0x806f05070302ffff

**Severity**

Error

**Serviceable**

Yes

**Automatically notify support**

No

**Alert Category**

Critical - CPU

**SNMP Trap ID**

40

**CIM Information**

Prefix: PLAT ID: 0062

**User Response**

1. Check the CPU LED. See more information about the CPU LED in Light path diagnostics.



2. Check for a server firmware update. Important: Some cluster solutions require specific code levels or coordinated code updates. If the device is part of a cluster solution, verify that the latest level of code is supported for the cluster solution before you update the code.
  3. Make sure that the installed microprocessors are compatible with each other.
  4. (Trained technician only) Reseat microprocessor n.
  5. (Trained technician only) Replace microprocessor n. (n = microprocessor number)
- **806f0507-2584ffff : [ProcessorElementName] has a Configuration Mismatch. (All CPUs)**

This message is for the use case when an implementation has detected a Processor Configuration Mismatch has occurred.

May also be shown as 806f05072584ffff or 0x806f05072584ffff

**Severity**

Error

**Serviceable**

Yes

**Automatically notify support**

No

**Alert Category**

Critical - CPU

**SNMP Trap ID**

40

**CIM Information**

**Prefix:** PLAT ID: 0062

**User Response**

1. Check the CPU LED. See more information about the CPU LED in Light path diagnostics.
2. Check for a server firmware update. Important: Some cluster solutions require specific code levels or coordinated code updates. If the device is part of a cluster solution, verify that the latest level of code is supported for the cluster solution before you update the code.
3. Make sure that the installed microprocessors are compatible with each other.
4. (Trained technician only) Reseat microprocessor n.
5. (Trained technician only) Replace microprocessor n. (n = microprocessor number)

One of the CPUs :

- **806f050c-2001ffff : Memory Logging Limit Reached for [PhysicalMemoryElementName] on Subsystem [MemoryElementName]. (DIMM 1)**

This message is for the use case when an implementation has detected that the Memory Logging Limit has been Reached.

May also be shown as 806f050c2001ffff or 0x806f050c2001ffff

**Severity**

Warning

**Serviceable**

Yes

**Automatically notify support**

Yes

**Alert Category**

Warning - Memory

**SNMP Trap ID**

43

**CIM Information****Prefix:** PLAT ID: 0144**User Response**

Note: Each time you install or remove a DIMM, you must disconnect the server from the power source; then, wait 10 seconds before restarting the server.

1. Refer to TIP H212293 for minimum code level.
  2. Check the Lenovo support website for an applicable retain tip or firmware update that applies to this memory error.
  3. Swap the affected DIMMs (as indicated by the error LEDs on the system board or the event logs) to a different memory channel or microprocessor.
  4. If the error still occurs on the same DIMM, replace the affected DIMM.
  5. (Trained technician only) If the problem occurs on the same DIMM connector, check the DIMM connector. If the connector contains any foreign material or is damaged, replace the system board.
  6. (Trained technician only) Remove the affected microprocessor and check the microprocessor socket pins for any damaged pins. If a damage is found, replace the system board.
  7. (Trained technician only) Replace the affected microprocessor.
- **806f050c-2002ffff : Memory Logging Limit Reached for [PhysicalMemoryElementName] on Subsystem [MemoryElementName]. (DIMM 2)**

This message is for the use case when an implementation has detected that the Memory Logging Limit has been Reached.

May also be shown as 806f050c2002ffff or 0x806f050c2002ffff

**Severity**

Warning

**Serviceable**

Yes

**Automatically notify support**

Yes

**Alert Category**

Warning - Memory

**SNMP Trap ID**

43

**CIM Information****Prefix:** PLAT ID: 0144**User Response**

Note: Each time you install or remove a DIMM, you must disconnect the server from the power source; then, wait 10 seconds before restarting the server.

1. Refer to TIP H212293 for minimum code level.
2. Check the Lenovo support website for an applicable retain tip or firmware update that applies to this memory error.
3. Swap the affected DIMMs (as indicated by the error LEDs on the system board or the event logs) to a different memory channel or microprocessor.
4. If the error still occurs on the same DIMM, replace the affected DIMM.

5. (Trained technician only) If the problem occurs on the same DIMM connector, check the DIMM connector. If the connector contains any foreign material or is damaged, replace the system board.
6. (Trained technician only) Remove the affected microprocessor and check the microprocessor socket pins for any damaged pins. If a damage is found, replace the system board.
7. (Trained technician only) Replace the affected microprocessor.

- **806f050c-2003ffff : Memory Logging Limit Reached for [PhysicalMemoryElementName] on Subsystem [MemoryElementName]. (DIMM 3)**

This message is for the use case when an implementation has detected that the Memory Logging Limit has been Reached.

May also be shown as 806f050c2003ffff or 0x806f050c2003ffff

**Severity**

Warning

**Serviceable**

Yes

**Automatically notify support**

Yes

**Alert Category**

Warning - Memory

**SNMP Trap ID**

43

**CIM Information**

Prefix: PLAT ID: 0144

**User Response**

Note: Each time you install or remove a DIMM, you must disconnect the server from the power source; then, wait 10 seconds before restarting the server.

1. Refer to TIP H212293 for minimum code level.
2. Check the Lenovo support website for an applicable retain tip or firmware update that applies to this memory error.
3. Swap the affected DIMMs (as indicated by the error LEDs on the system board or the event logs) to a different memory channel or microprocessor.
4. If the error still occurs on the same DIMM, replace the affected DIMM.
5. (Trained technician only) If the problem occurs on the same DIMM connector, check the DIMM connector. If the connector contains any foreign material or is damaged, replace the system board.
6. (Trained technician only) Remove the affected microprocessor and check the microprocessor socket pins for any damaged pins. If a damage is found, replace the system board.
7. (Trained technician only) Replace the affected microprocessor.

- **806f050c-2004ffff : Memory Logging Limit Reached for [PhysicalMemoryElementName] on Subsystem [MemoryElementName]. (DIMM 4)**

This message is for the use case when an implementation has detected that the Memory Logging Limit has been Reached.

May also be shown as 806f050c2004ffff or 0x806f050c2004ffff

**Severity**

Warning

**Serviceable**

Yes

**Automatically notify support**

Yes

**Alert Category**

Warning - Memory

**SNMP Trap ID**

43

**CIM Information**

**Prefix:** PLAT ID: 0144

**User Response**

Note: Each time you install or remove a DIMM, you must disconnect the server from the power source; then, wait 10 seconds before restarting the server.

1. Refer to TIP H212293 for minimum code level.
  2. Check the Lenovo support website for an applicable retain tip or firmware update that applies to this memory error.
  3. Swap the affected DIMMs (as indicated by the error LEDs on the system board or the event logs) to a different memory channel or microprocessor.
  4. If the error still occurs on the same DIMM, replace the affected DIMM.
  5. (Trained technician only) If the problem occurs on the same DIMM connector, check the DIMM connector. If the connector contains any foreign material or is damaged, replace the system board.
  6. (Trained technician only) Remove the affected microprocessor and check the microprocessor socket pins for any damaged pins. If a damage is found, replace the system board.
  7. (Trained technician only) Replace the affected microprocessor.
- **806f050c-2005ffff : Memory Logging Limit Reached for [PhysicalMemoryElementName] on Subsystem [MemoryElementName]. (DIMM 5)**

This message is for the use case when an implementation has detected that the Memory Logging Limit has been Reached.

May also be shown as 806f050c2005ffff or 0x806f050c2005ffff

**Severity**

Warning

**Serviceable**

Yes

**Automatically notify support**

Yes

**Alert Category**

Warning - Memory

**SNMP Trap ID**

43

**CIM Information**

**Prefix:** PLAT ID: 0144

**User Response**

Note: Each time you install or remove a DIMM, you must disconnect the server from the power source; then, wait 10 seconds before restarting the server.

1. Refer to TIP H212293 for minimum code level.
2. Check the Lenovo support website for an applicable retain tip or firmware update that applies to this memory error.
3. Swap the affected DIMMs (as indicated by the error LEDs on the system board or the event logs) to a different memory channel or microprocessor.
4. If the error still occurs on the same DIMM, replace the affected DIMM.
5. (Trained technician only) If the problem occurs on the same DIMM connector, check the DIMM connector. If the connector contains any foreign material or is damaged, replace the system board.
6. (Trained technician only) Remove the affected microprocessor and check the microprocessor socket pins for any damaged pins. If a damage is found, replace the system board.
7. (Trained technician only) Replace the affected microprocessor.

- **806f050c-2006ffff : Memory Logging Limit Reached for [PhysicalMemoryElementName] on Subsystem [MemoryElementName]. (DIMM 6)**

This message is for the use case when an implementation has detected that the Memory Logging Limit has been Reached.

May also be shown as 806f050c2006ffff or 0x806f050c2006ffff

**Severity**

Warning

**Serviceable**

Yes

**Automatically notify support**

Yes

**Alert Category**

Warning - Memory

**SNMP Trap ID**

43

**CIM Information**

**Prefix:** PLAT ID: 0144

**User Response**

Note: Each time you install or remove a DIMM, you must disconnect the server from the power source; then, wait 10 seconds before restarting the server.

1. Refer to TIP H212293 for minimum code level.
  2. Check the Lenovo support website for an applicable retain tip or firmware update that applies to this memory error.
  3. Swap the affected DIMMs (as indicated by the error LEDs on the system board or the event logs) to a different memory channel or microprocessor.
  4. If the error still occurs on the same DIMM, replace the affected DIMM.
  5. (Trained technician only) If the problem occurs on the same DIMM connector, check the DIMM connector. If the connector contains any foreign material or is damaged, replace the system board.
  6. (Trained technician only) Remove the affected microprocessor and check the microprocessor socket pins for any damaged pins. If a damage is found, replace the system board.
  7. (Trained technician only) Replace the affected microprocessor.
- **806f050c-2007ffff : Memory Logging Limit Reached for [PhysicalMemoryElementName] on Subsystem [MemoryElementName]. (DIMM 7)**

This message is for the use case when an implementation has detected that the Memory Logging Limit has been Reached.

May also be shown as 806f050c2007ffff or 0x806f050c2007ffff

**Severity**

Warning

**Serviceable**

Yes

**Automatically notify support**

Yes

**Alert Category**

Warning - Memory

**SNMP Trap ID**

43

**CIM Information**

Prefix: PLAT ID: 0144

**User Response**

Note: Each time you install or remove a DIMM, you must disconnect the server from the power source; then, wait 10 seconds before restarting the server.

1. Refer to TIP H212293 for minimum code level.
  2. Check the Lenovo support website for an applicable retain tip or firmware update that applies to this memory error.
  3. Swap the affected DIMMs (as indicated by the error LEDs on the system board or the event logs) to a different memory channel or microprocessor.
  4. If the error still occurs on the same DIMM, replace the affected DIMM.
  5. (Trained technician only) If the problem occurs on the same DIMM connector, check the DIMM connector. If the connector contains any foreign material or is damaged, replace the system board.
  6. (Trained technician only) Remove the affected microprocessor and check the microprocessor socket pins for any damaged pins. If a damage is found, replace the system board.
  7. (Trained technician only) Replace the affected microprocessor.
- **806f050c-2008ffff : Memory Logging Limit Reached for [PhysicalMemoryElementName] on Subsystem [MemoryElementName]. (DIMM 8)**

This message is for the use case when an implementation has detected that the Memory Logging Limit has been Reached.

May also be shown as 806f050c2008ffff or 0x806f050c2008ffff

**Severity**

Warning

**Serviceable**

Yes

**Automatically notify support**

Yes

**Alert Category**

Warning - Memory

**SNMP Trap ID**

**CIM Information****Prefix:** PLAT ID: 0144**User Response**

Note: Each time you install or remove a DIMM, you must disconnect the server from the power source; then, wait 10 seconds before restarting the server.

1. Refer to TIP H212293 for minimum code level.
  2. Check the Lenovo support website for an applicable retain tip or firmware update that applies to this memory error.
  3. Swap the affected DIMMs (as indicated by the error LEDs on the system board or the event logs) to a different memory channel or microprocessor.
  4. If the error still occurs on the same DIMM, replace the affected DIMM.
  5. (Trained technician only) If the problem occurs on the same DIMM connector, check the DIMM connector. If the connector contains any foreign material or is damaged, replace the system board.
  6. (Trained technician only) Remove the affected microprocessor and check the microprocessor socket pins for any damaged pins. If a damage is found, replace the system board.
  7. (Trained technician only) Replace the affected microprocessor.
- **806f050c-2009ffff : Memory Logging Limit Reached for [PhysicalMemoryElementName] on Subsystem [MemoryElementName]. (DIMM 9)**

This message is for the use case when an implementation has detected that the Memory Logging Limit has been Reached.

May also be shown as 806f050c2009ffff or 0x806f050c2009ffff

**Severity**

Warning

**Serviceable**

Yes

**Automatically notify support**

Yes

**Alert Category**

Warning - Memory

**SNMP Trap ID**

43

**CIM Information****Prefix:** PLAT ID: 0144**User Response**

Note: Each time you install or remove a DIMM, you must disconnect the server from the power source; then, wait 10 seconds before restarting the server.

1. Refer to TIP H212293 for minimum code level.
2. Check the Lenovo support website for an applicable retain tip or firmware update that applies to this memory error.
3. Swap the affected DIMMs (as indicated by the error LEDs on the system board or the event logs) to a different memory channel or microprocessor.
4. If the error still occurs on the same DIMM, replace the affected DIMM.

5. (Trained technician only) If the problem occurs on the same DIMM connector, check the DIMM connector. If the connector contains any foreign material or is damaged, replace the system board.
6. (Trained technician only) Remove the affected microprocessor and check the microprocessor socket pins for any damaged pins. If a damage is found, replace the system board.
7. (Trained technician only) Replace the affected microprocessor.

- **806f050c-200affff : Memory Logging Limit Reached for [PhysicalMemoryElementName] on Subsystem [MemoryElementName]. (DIMM 10)**

This message is for the use case when an implementation has detected that the Memory Logging Limit has been Reached.

May also be shown as 806f050c200affff or 0x806f050c200affff

**Severity**

Warning

**Serviceable**

Yes

**Automatically notify support**

Yes

**Alert Category**

Warning - Memory

**SNMP Trap ID**

43

**CIM Information**

Prefix: PLAT ID: 0144

**User Response**

Note: Each time you install or remove a DIMM, you must disconnect the server from the power source; then, wait 10 seconds before restarting the server.

1. Refer to TIP H212293 for minimum code level.
2. Check the Lenovo support website for an applicable retain tip or firmware update that applies to this memory error.
3. Swap the affected DIMMs (as indicated by the error LEDs on the system board or the event logs) to a different memory channel or microprocessor.
4. If the error still occurs on the same DIMM, replace the affected DIMM.
5. (Trained technician only) If the problem occurs on the same DIMM connector, check the DIMM connector. If the connector contains any foreign material or is damaged, replace the system board.
6. (Trained technician only) Remove the affected microprocessor and check the microprocessor socket pins for any damaged pins. If a damage is found, replace the system board.
7. (Trained technician only) Replace the affected microprocessor.

- **806f050c-200bffff : Memory Logging Limit Reached for [PhysicalMemoryElementName] on Subsystem [MemoryElementName]. (DIMM 11)**

This message is for the use case when an implementation has detected that the Memory Logging Limit has been Reached.

May also be shown as 806f050c200bffff or 0x806f050c200bffff

**Severity**

Warning



**Serviceable**

Yes

**Automatically notify support**

Yes

**Alert Category**

Warning - Memory

**SNMP Trap ID**

43

**CIM Information****Prefix:** PLAT ID: 0144**User Response**

Note: Each time you install or remove a DIMM, you must disconnect the server from the power source; then, wait 10 seconds before restarting the server.

1. Refer to TIP H212293 for minimum code level.
  2. Check the Lenovo support website for an applicable retain tip or firmware update that applies to this memory error.
  3. Swap the affected DIMMs (as indicated by the error LEDs on the system board or the event logs) to a different memory channel or microprocessor.
  4. If the error still occurs on the same DIMM, replace the affected DIMM.
  5. (Trained technician only) If the problem occurs on the same DIMM connector, check the DIMM connector. If the connector contains any foreign material or is damaged, replace the system board.
  6. (Trained technician only) Remove the affected microprocessor and check the microprocessor socket pins for any damaged pins. If a damage is found, replace the system board.
  7. (Trained technician only) Replace the affected microprocessor.
- **806f050c-200cffff : Memory Logging Limit Reached for [PhysicalMemoryElementName] on Subsystem [MemoryElementName]. (DIMM 12)**

This message is for the use case when an implementation has detected that the Memory Logging Limit has been Reached.

May also be shown as 806f050c200cffff or 0x806f050c200cffff

**Severity**

Warning

**Serviceable**

Yes

**Automatically notify support**

Yes

**Alert Category**

Warning - Memory

**SNMP Trap ID**

43

**CIM Information****Prefix:** PLAT ID: 0144**User Response**

Note: Each time you install or remove a DIMM, you must disconnect the server from the power source; then, wait 10 seconds before restarting the server.

1. Refer to TIP H212293 for minimum code level.
2. Check the Lenovo support website for an applicable retain tip or firmware update that applies to this memory error.
3. Swap the affected DIMMs (as indicated by the error LEDs on the system board or the event logs) to a different memory channel or microprocessor.
4. If the error still occurs on the same DIMM, replace the affected DIMM.
5. (Trained technician only) If the problem occurs on the same DIMM connector, check the DIMM connector. If the connector contains any foreign material or is damaged, replace the system board.
6. (Trained technician only) Remove the affected microprocessor and check the microprocessor socket pins for any damaged pins. If a damage is found, replace the system board.
7. (Trained technician only) Replace the affected microprocessor.

- **806f050c-200dffff : Memory Logging Limit Reached for [PhysicalMemoryElementName] on Subsystem [MemoryElementName]. (DIMM 13)**

This message is for the use case when an implementation has detected that the Memory Logging Limit has been Reached.

May also be shown as 806f050c200dffff or 0x806f050c200dffff

**Severity**

Warning

**Serviceable**

Yes

**Automatically notify support**

Yes

**Alert Category**

Warning - Memory

**SNMP Trap ID**

43

**CIM Information**

**Prefix:** PLAT ID: 0144

**User Response**

Note: Each time you install or remove a DIMM, you must disconnect the server from the power source; then, wait 10 seconds before restarting the server.

1. Refer to TIP H212293 for minimum code level.
  2. Check the Lenovo support website for an applicable retain tip or firmware update that applies to this memory error.
  3. Swap the affected DIMMs (as indicated by the error LEDs on the system board or the event logs) to a different memory channel or microprocessor.
  4. If the error still occurs on the same DIMM, replace the affected DIMM.
  5. (Trained technician only) If the problem occurs on the same DIMM connector, check the DIMM connector. If the connector contains any foreign material or is damaged, replace the system board.
  6. (Trained technician only) Remove the affected microprocessor and check the microprocessor socket pins for any damaged pins. If a damage is found, replace the system board.
  7. (Trained technician only) Replace the affected microprocessor.
- **806f050c-200effff : Memory Logging Limit Reached for [PhysicalMemoryElementName] on Subsystem [MemoryElementName]. (DIMM 14)**

This message is for the use case when an implementation has detected that the Memory Logging Limit has been Reached.

May also be shown as 806f050c200effff or 0x806f050c200effff

**Severity**

Warning

**Serviceable**

Yes

**Automatically notify support**

Yes

**Alert Category**

Warning - Memory

**SNMP Trap ID**

43

**CIM Information**

Prefix: PLAT ID: 0144

**User Response**

Note: Each time you install or remove a DIMM, you must disconnect the server from the power source; then, wait 10 seconds before restarting the server.

1. Refer to TIP H212293 for minimum code level.
  2. Check the Lenovo support website for an applicable retain tip or firmware update that applies to this memory error.
  3. Swap the affected DIMMs (as indicated by the error LEDs on the system board or the event logs) to a different memory channel or microprocessor.
  4. If the error still occurs on the same DIMM, replace the affected DIMM.
  5. (Trained technician only) If the problem occurs on the same DIMM connector, check the DIMM connector. If the connector contains any foreign material or is damaged, replace the system board.
  6. (Trained technician only) Remove the affected microprocessor and check the microprocessor socket pins for any damaged pins. If a damage is found, replace the system board.
  7. (Trained technician only) Replace the affected microprocessor.
- **806f050c-200ffff : Memory Logging Limit Reached for [PhysicalMemoryElementName] on Subsystem [MemoryElementName]. (DIMM 15)**

This message is for the use case when an implementation has detected that the Memory Logging Limit has been Reached.

May also be shown as 806f050c200fffff or 0x806f050c200fffff

**Severity**

Warning

**Serviceable**

Yes

**Automatically notify support**

Yes

**Alert Category**

Warning - Memory

**SNMP Trap ID**

**CIM Information****Prefix:** PLAT ID: 0144**User Response**

Note: Each time you install or remove a DIMM, you must disconnect the server from the power source; then, wait 10 seconds before restarting the server.

1. Refer to TIP H212293 for minimum code level.
  2. Check the Lenovo support website for an applicable retain tip or firmware update that applies to this memory error.
  3. Swap the affected DIMMs (as indicated by the error LEDs on the system board or the event logs) to a different memory channel or microprocessor.
  4. If the error still occurs on the same DIMM, replace the affected DIMM.
  5. (Trained technician only) If the problem occurs on the same DIMM connector, check the DIMM connector. If the connector contains any foreign material or is damaged, replace the system board.
  6. (Trained technician only) Remove the affected microprocessor and check the microprocessor socket pins for any damaged pins. If a damage is found, replace the system board.
  7. (Trained technician only) Replace the affected microprocessor.
- **806f050c-2010ffff : Memory Logging Limit Reached for [PhysicalMemoryElementName] on Subsystem [MemoryElementName]. (DIMM 16)**

This message is for the use case when an implementation has detected that the Memory Logging Limit has been Reached.

May also be shown as 806f050c2010ffff or 0x806f050c2010ffff

**Severity**

Warning

**Serviceable**

Yes

**Automatically notify support**

Yes

**Alert Category**

Warning - Memory

**SNMP Trap ID**

43

**CIM Information****Prefix:** PLAT ID: 0144**User Response**

Note: Each time you install or remove a DIMM, you must disconnect the server from the power source; then, wait 10 seconds before restarting the server.

1. Refer to TIP H212293 for minimum code level.
2. Check the Lenovo support website for an applicable retain tip or firmware update that applies to this memory error.
3. Swap the affected DIMMs (as indicated by the error LEDs on the system board or the event logs) to a different memory channel or microprocessor.
4. If the error still occurs on the same DIMM, replace the affected DIMM.

5. (Trained technician only) If the problem occurs on the same DIMM connector, check the DIMM connector. If the connector contains any foreign material or is damaged, replace the system board.
6. (Trained technician only) Remove the affected microprocessor and check the microprocessor socket pins for any damaged pins. If a damage is found, replace the system board.
7. (Trained technician only) Replace the affected microprocessor.

- **806f050c-2011ffff : Memory Logging Limit Reached for [PhysicalMemoryElementName] on Subsystem [MemoryElementName]. (DIMM 17)**

This message is for the use case when an implementation has detected that the Memory Logging Limit has been Reached.

May also be shown as 806f050c2011ffff or 0x806f050c2011ffff

**Severity**

Warning

**Serviceable**

Yes

**Automatically notify support**

Yes

**Alert Category**

Warning - Memory

**SNMP Trap ID**

43

**CIM Information**

Prefix: PLAT ID: 0144

**User Response**

Note: Each time you install or remove a DIMM, you must disconnect the server from the power source; then, wait 10 seconds before restarting the server.

1. Refer to TIP H212293 for minimum code level.
2. Check the Lenovo support website for an applicable retain tip or firmware update that applies to this memory error.
3. Swap the affected DIMMs (as indicated by the error LEDs on the system board or the event logs) to a different memory channel or microprocessor.
4. If the error still occurs on the same DIMM, replace the affected DIMM.
5. (Trained technician only) If the problem occurs on the same DIMM connector, check the DIMM connector. If the connector contains any foreign material or is damaged, replace the system board.
6. (Trained technician only) Remove the affected microprocessor and check the microprocessor socket pins for any damaged pins. If a damage is found, replace the system board.
7. (Trained technician only) Replace the affected microprocessor.

- **806f050c-2012ffff : Memory Logging Limit Reached for [PhysicalMemoryElementName] on Subsystem [MemoryElementName]. (DIMM 18)**

This message is for the use case when an implementation has detected that the Memory Logging Limit has been Reached.

May also be shown as 806f050c2012ffff or 0x806f050c2012ffff

**Severity**

Warning

**Serviceable**

Yes

**Automatically notify support**

Yes

**Alert Category**

Warning - Memory

**SNMP Trap ID**

43

**CIM Information**

**Prefix:** PLAT ID: 0144

**User Response**

Note: Each time you install or remove a DIMM, you must disconnect the server from the power source; then, wait 10 seconds before restarting the server.

1. Refer to TIP H212293 for minimum code level.
  2. Check the Lenovo support website for an applicable retain tip or firmware update that applies to this memory error.
  3. Swap the affected DIMMs (as indicated by the error LEDs on the system board or the event logs) to a different memory channel or microprocessor.
  4. If the error still occurs on the same DIMM, replace the affected DIMM.
  5. (Trained technician only) If the problem occurs on the same DIMM connector, check the DIMM connector. If the connector contains any foreign material or is damaged, replace the system board.
  6. (Trained technician only) Remove the affected microprocessor and check the microprocessor socket pins for any damaged pins. If a damage is found, replace the system board.
  7. (Trained technician only) Replace the affected microprocessor.
- **806f050c-2013ffff : Memory Logging Limit Reached for [PhysicalMemoryElementName] on Subsystem [MemoryElementName]. (DIMM 19)**

This message is for the use case when an implementation has detected that the Memory Logging Limit has been Reached.

May also be shown as 806f050c2013ffff or 0x806f050c2013ffff

**Severity**

Warning

**Serviceable**

Yes

**Automatically notify support**

Yes

**Alert Category**

Warning - Memory

**SNMP Trap ID**

43

**CIM Information**

**Prefix:** PLAT ID: 0144

**User Response**

Note: Each time you install or remove a DIMM, you must disconnect the server from the power source; then, wait 10 seconds before restarting the server.

1. Refer to TIP H212293 for minimum code level.
2. Check the Lenovo support website for an applicable retain tip or firmware update that applies to this memory error.
3. Swap the affected DIMMs (as indicated by the error LEDs on the system board or the event logs) to a different memory channel or microprocessor.
4. If the error still occurs on the same DIMM, replace the affected DIMM.
5. (Trained technician only) If the problem occurs on the same DIMM connector, check the DIMM connector. If the connector contains any foreign material or is damaged, replace the system board.
6. (Trained technician only) Remove the affected microprocessor and check the microprocessor socket pins for any damaged pins. If a damage is found, replace the system board.
7. (Trained technician only) Replace the affected microprocessor.

- **806f050c-2014ffff : Memory Logging Limit Reached for [PhysicalMemoryElementName] on Subsystem [MemoryElementName]. (DIMM 20)**

This message is for the use case when an implementation has detected that the Memory Logging Limit has been Reached.

May also be shown as 806f050c2014ffff or 0x806f050c2014ffff

**Severity**

Warning

**Serviceable**

Yes

**Automatically notify support**

Yes

**Alert Category**

Warning - Memory

**SNMP Trap ID**

43

**CIM Information**

**Prefix:** PLAT ID: 0144

**User Response**

Note: Each time you install or remove a DIMM, you must disconnect the server from the power source; then, wait 10 seconds before restarting the server.

1. Refer to TIP H212293 for minimum code level.
  2. Check the Lenovo support website for an applicable retain tip or firmware update that applies to this memory error.
  3. Swap the affected DIMMs (as indicated by the error LEDs on the system board or the event logs) to a different memory channel or microprocessor.
  4. If the error still occurs on the same DIMM, replace the affected DIMM.
  5. (Trained technician only) If the problem occurs on the same DIMM connector, check the DIMM connector. If the connector contains any foreign material or is damaged, replace the system board.
  6. (Trained technician only) Remove the affected microprocessor and check the microprocessor socket pins for any damaged pins. If a damage is found, replace the system board.
  7. (Trained technician only) Replace the affected microprocessor.
- **806f050c-2015ffff : Memory Logging Limit Reached for [PhysicalMemoryElementName] on Subsystem [MemoryElementName]. (DIMM 21)**

This message is for the use case when an implementation has detected that the Memory Logging Limit has been Reached.

May also be shown as 806f050c2015ffff or 0x806f050c2015ffff

**Severity**

Warning

**Serviceable**

Yes

**Automatically notify support**

Yes

**Alert Category**

Warning - Memory

**SNMP Trap ID**

43

**CIM Information**

Prefix: PLAT ID: 0144

**User Response**

Note: Each time you install or remove a DIMM, you must disconnect the server from the power source; then, wait 10 seconds before restarting the server.

1. Refer to TIP H212293 for minimum code level.
2. Check the Lenovo support website for an applicable retain tip or firmware update that applies to this memory error.
3. Swap the affected DIMMs (as indicated by the error LEDs on the system board or the event logs) to a different memory channel or microprocessor.
4. If the error still occurs on the same DIMM, replace the affected DIMM.
5. (Trained technician only) If the problem occurs on the same DIMM connector, check the DIMM connector. If the connector contains any foreign material or is damaged, replace the system board.
6. (Trained technician only) Remove the affected microprocessor and check the microprocessor socket pins for any damaged pins. If a damage is found, replace the system board.
7. (Trained technician only) Replace the affected microprocessor.

- **806f050c-2016ffff : Memory Logging Limit Reached for [PhysicalMemoryElementName] on Subsystem [MemoryElementName]. (DIMM 22)**

This message is for the use case when an implementation has detected that the Memory Logging Limit has been Reached.

May also be shown as 806f050c2016ffff or 0x806f050c2016ffff

**Severity**

Warning

**Serviceable**

Yes

**Automatically notify support**

Yes

**Alert Category**

Warning - Memory

**SNMP Trap ID**



**CIM Information****Prefix:** PLAT ID: 0144**User Response**

Note: Each time you install or remove a DIMM, you must disconnect the server from the power source; then, wait 10 seconds before restarting the server.

1. Refer to TIP H212293 for minimum code level.
  2. Check the Lenovo support website for an applicable retain tip or firmware update that applies to this memory error.
  3. Swap the affected DIMMs (as indicated by the error LEDs on the system board or the event logs) to a different memory channel or microprocessor.
  4. If the error still occurs on the same DIMM, replace the affected DIMM.
  5. (Trained technician only) If the problem occurs on the same DIMM connector, check the DIMM connector. If the connector contains any foreign material or is damaged, replace the system board.
  6. (Trained technician only) Remove the affected microprocessor and check the microprocessor socket pins for any damaged pins. If a damage is found, replace the system board.
  7. (Trained technician only) Replace the affected microprocessor.
- **806f050c-2017ffff : Memory Logging Limit Reached for [PhysicalMemoryElementName] on Subsystem [MemoryElementName]. (DIMM 23)**

This message is for the use case when an implementation has detected that the Memory Logging Limit has been Reached.

May also be shown as 806f050c2017ffff or 0x806f050c2017ffff

**Severity**

Warning

**Serviceable**

Yes

**Automatically notify support**

Yes

**Alert Category**

Warning - Memory

**SNMP Trap ID**

43

**CIM Information****Prefix:** PLAT ID: 0144**User Response**

Note: Each time you install or remove a DIMM, you must disconnect the server from the power source; then, wait 10 seconds before restarting the server.

1. Refer to TIP H212293 for minimum code level.
2. Check the Lenovo support website for an applicable retain tip or firmware update that applies to this memory error.
3. Swap the affected DIMMs (as indicated by the error LEDs on the system board or the event logs) to a different memory channel or microprocessor.
4. If the error still occurs on the same DIMM, replace the affected DIMM.

5. (Trained technician only) If the problem occurs on the same DIMM connector, check the DIMM connector. If the connector contains any foreign material or is damaged, replace the system board.
6. (Trained technician only) Remove the affected microprocessor and check the microprocessor socket pins for any damaged pins. If a damage is found, replace the system board.
7. (Trained technician only) Replace the affected microprocessor.

- **806f050c-2018ffff : Memory Logging Limit Reached for [PhysicalMemoryElementName] on Subsystem [MemoryElementName]. (DIMM 24)**

This message is for the use case when an implementation has detected that the Memory Logging Limit has been Reached.

May also be shown as 806f050c2018ffff or 0x806f050c2018ffff

**Severity**

Warning

**Serviceable**

Yes

**Automatically notify support**

Yes

**Alert Category**

Warning - Memory

**SNMP Trap ID**

43

**CIM Information**

Prefix: PLAT ID: 0144

**User Response**

Note: Each time you install or remove a DIMM, you must disconnect the server from the power source; then, wait 10 seconds before restarting the server.

1. Refer to TIP H212293 for minimum code level.
2. Check the Lenovo support website for an applicable retain tip or firmware update that applies to this memory error.
3. Swap the affected DIMMs (as indicated by the error LEDs on the system board or the event logs) to a different memory channel or microprocessor.
4. If the error still occurs on the same DIMM, replace the affected DIMM.
5. (Trained technician only) If the problem occurs on the same DIMM connector, check the DIMM connector. If the connector contains any foreign material or is damaged, replace the system board.
6. (Trained technician only) Remove the affected microprocessor and check the microprocessor socket pins for any damaged pins. If a damage is found, replace the system board.
7. (Trained technician only) Replace the affected microprocessor.

- **806f050c-2581ffff : Memory Logging Limit Reached for [PhysicalMemoryElementName] on Subsystem [MemoryElementName]. (All DIMMS)**

This message is for the use case when an implementation has detected that the Memory Logging Limit has been Reached.

May also be shown as 806f050c2581ffff or 0x806f050c2581ffff

**Severity**

Warning

**Serviceable**

Yes

**Automatically notify support**

Yes

**Alert Category**

Warning - Memory

**SNMP Trap ID**

43

**CIM Information****Prefix:** PLAT ID: 0144**User Response**

Note: Each time you install or remove a DIMM, you must disconnect the server from the power source; then, wait 10 seconds before restarting the server.

1. Refer to TIP H212293 for minimum code level.
2. Check the Lenovo support website for an applicable retain tip or firmware update that applies to this memory error.
3. Swap the affected DIMMs (as indicated by the error LEDs on the system board or the event logs) to a different memory channel or microprocessor.
4. If the error still occurs on the same DIMM, replace the affected DIMM.
5. (Trained technician only) If the problem occurs on the same DIMM connector, check the DIMM connector. If the connector contains any foreign material or is damaged, replace the system board.
6. (Trained technician only) Remove the affected microprocessor and check the microprocessor socket pins for any damaged pins. If a damage is found, replace the system board.
7. (Trained technician only) Replace the affected microprocessor.

One of the DIMMs :

- **806f050d-0400ffff : Array [ComputerSystemElementName] is in critical condition. (Drive 0)**

This message is for the use case when an implementation has detected that an Array is Critical.

May also be shown as 806f050d0400ffff or 0x806f050d0400ffff

**Severity**

Error

**Serviceable**

Yes

**Automatically notify support**

No

**Alert Category**

Critical - Hard Disk drive

**SNMP Trap ID**

5

**CIM Information****Prefix:** PLAT ID: 0174**User Response**

1. Make sure that the RAID adapter firmware and hard disk drive firmware are at the latest level.
2. Make sure that the SAS cable is connected correctly.

3. Replace the SAS cable.
  4. Check backplane cable connection.
  5. Replace the RAID adapter.
  6. Replace the hard disk drive that is indicated by a lit status LED.
- **806f050d-0401ffff : Array [ComputerSystemElementName] is in critical condition. (Drive 1)**

This message is for the use case when an implementation has detected that an Array is Critical.  
May also be shown as 806f050d0401ffff or 0x806f050d0401ffff

**Severity**

Error

**Serviceable**

Yes

**Automatically notify support**

No

**Alert Category**

Critical - Hard Disk drive

**SNMP Trap ID**

5

**CIM Information**

**Prefix: PLAT ID:** 0174

**User Response**

1. Make sure that the RAID adapter firmware and hard disk drive firmware are at the latest level.
  2. Make sure that the SAS cable is connected correctly.
  3. Replace the SAS cable.
  4. Check backplane cable connection.
  5. Replace the RAID adapter.
  6. Replace the hard disk drive that is indicated by a lit status LED.
- **806f050d-0402ffff : Array [ComputerSystemElementName] is in critical condition. (Drive 2)**

This message is for the use case when an implementation has detected that an Array is Critical.  
May also be shown as 806f050d0402ffff or 0x806f050d0402ffff

**Severity**

Error

**Serviceable**

Yes

**Automatically notify support**

No

**Alert Category**

Critical - Hard Disk drive

**SNMP Trap ID**

5

**CIM Information**

**Prefix: PLAT ID:** 0174

**User Response**

1. Make sure that the RAID adapter firmware and hard disk drive firmware are at the latest level.
  2. Make sure that the SAS cable is connected correctly.
  3. Replace the SAS cable.
  4. Check backplane cable connection.
  5. Replace the RAID adapter.
  6. Replace the hard disk drive that is indicated by a lit status LED.
- **806f050d-0403ffff : Array [ComputerSystemElementName] is in critical condition. (Drive 3)**  
 This message is for the use case when an implementation has detected that an Array is Critical.  
 May also be shown as 806f050d0403ffff or 0x806f050d0403ffff

**Severity**

Error

**Serviceable**

Yes

**Automatically notify support**

No

**Alert Category**

Critical - Hard Disk drive

**SNMP Trap ID**

5

**CIM Information**

Prefix: PLAT ID: 0174

**User Response**

1. Make sure that the RAID adapter firmware and hard disk drive firmware are at the latest level.
  2. Make sure that the SAS cable is connected correctly.
  3. Replace the SAS cable.
  4. Check backplane cable connection.
  5. Replace the RAID adapter.
  6. Replace the hard disk drive that is indicated by a lit status LED.
- **806f050d-0404ffff : Array [ComputerSystemElementName] is in critical condition. (Drive 4)**  
 This message is for the use case when an implementation has detected that an Array is Critical.  
 May also be shown as 806f050d0404ffff or 0x806f050d0404ffff

**Severity**

Error

**Serviceable**

Yes

**Automatically notify support**

No

**Alert Category**

Critical - Hard Disk drive

**SNMP Trap ID**

5

**CIM Information**

**Prefix: PLAT ID:** 0174

**User Response**

1. Make sure that the RAID adapter firmware and hard disk drive firmware are at the latest level.
  2. Make sure that the SAS cable is connected correctly.
  3. Replace the SAS cable.
  4. Check backplane cable connection.
  5. Replace the RAID adapter.
  6. Replace the hard disk drive that is indicated by a lit status LED.
- **806f050d-0405ffff : Array [ComputerSystemElementName] is in critical condition. (Drive 5)**

This message is for the use case when an implementation has detected that an Array is Critical.

May also be shown as 806f050d0405ffff or 0x806f050d0405ffff

**Severity**

Error

**Serviceable**

Yes

**Automatically notify support**

No

**Alert Category**

Critical - Hard Disk drive

**SNMP Trap ID**

5

**CIM Information**

**Prefix: PLAT ID:** 0174

**User Response**

1. Make sure that the RAID adapter firmware and hard disk drive firmware are at the latest level.
  2. Make sure that the SAS cable is connected correctly.
  3. Replace the SAS cable.
  4. Check backplane cable connection.
  5. Replace the RAID adapter.
  6. Replace the hard disk drive that is indicated by a lit status LED.
- **806f050d-0406ffff : Array [ComputerSystemElementName] is in critical condition. (Drive 6)**

This message is for the use case when an implementation has detected that an Array is Critical.

May also be shown as 806f050d0406ffff or 0x806f050d0406ffff

**Severity**

Error

**Serviceable**

Yes

**Automatically notify support**

No

**Alert Category**

Critical - Hard Disk drive

**SNMP Trap ID**

**CIM Information****Prefix:** PLAT ID: 0174**User Response**

1. Make sure that the RAID adapter firmware and hard disk drive firmware are at the latest level.
  2. Make sure that the SAS cable is connected correctly.
  3. Replace the SAS cable.
  4. Check backplane cable connection.
  5. Replace the RAID adapter.
  6. Replace the hard disk drive that is indicated by a lit status LED.
- **806f050d-0407ffff : Array [ComputerSystemElementName] is in critical condition. (Drive 7)**

This message is for the use case when an implementation has detected that an Array is Critical.

May also be shown as 806f050d0407ffff or 0x806f050d0407ffff

**Severity**

Error

**Serviceable**

Yes

**Automatically notify support**

No

**Alert Category**

Critical - Hard Disk drive

**SNMP Trap ID**

5

**CIM Information****Prefix:** PLAT ID: 0174**User Response**

1. Make sure that the RAID adapter firmware and hard disk drive firmware are at the latest level.
  2. Make sure that the SAS cable is connected correctly.
  3. Replace the SAS cable.
  4. Check backplane cable connection.
  5. Replace the RAID adapter.
  6. Replace the hard disk drive that is indicated by a lit status LED.
- **806f050d-0408ffff : Array [ComputerSystemElementName] is in critical condition. (Drive 8)**

This message is for the use case when an implementation has detected that an Array is Critical.

May also be shown as 806f050d0408ffff or 0x806f050d0408ffff

**Severity**

Error

**Serviceable**

Yes

**Automatically notify support**

No

**Alert Category**

Critical - Hard Disk drive

**SNMP Trap ID**

5

**CIM Information**

**Prefix:** PLAT ID: 0174

**User Response**

1. Make sure that the RAID adapter firmware and hard disk drive firmware are at the latest level.
  2. Make sure that the SAS cable is connected correctly.
  3. Replace the SAS cable.
  4. Check backplane cable connection.
  5. Replace the RAID adapter.
  6. Replace the hard disk drive that is indicated by a lit status LED.
- **806f050d-0409ffff : Array [ComputerSystemElementName] is in critical condition. (Drive 9)**

This message is for the use case when an implementation has detected that an Array is Critical.

May also be shown as 806f050d0409ffff or 0x806f050d0409ffff

**Severity**

Error

**Serviceable**

Yes

**Automatically notify support**

No

**Alert Category**

Critical - Hard Disk drive

**SNMP Trap ID**

5

**CIM Information**

**Prefix:** PLAT ID: 0174

**User Response**

1. Make sure that the RAID adapter firmware and hard disk drive firmware are at the latest level.
  2. Make sure that the SAS cable is connected correctly.
  3. Replace the SAS cable.
  4. Check backplane cable connection.
  5. Replace the RAID adapter.
  6. Replace the hard disk drive that is indicated by a lit status LED.
- **806f050d-040affff : Array [ComputerSystemElementName] is in critical condition. (Drive 10)**

This message is for the use case when an implementation has detected that an Array is Critical.

May also be shown as 806f050d040affff or 0x806f050d040affff

**Severity**

Error

**Serviceable**

Yes

**Automatically notify support**



No

**Alert Category**

Critical - Hard Disk drive

**SNMP Trap ID**

5

**CIM Information**

**Prefix:** PLAT ID: 0174

**User Response**

1. Make sure that the RAID adapter firmware and hard disk drive firmware are at the latest level.
  2. Make sure that the SAS cable is connected correctly.
  3. Replace the SAS cable.
  4. Check backplane cable connection.
  5. Replace the RAID adapter.
  6. Replace the hard disk drive that is indicated by a lit status LED.
- **806f050d-040bffff : Array [ComputerSystemElementName] is in critical condition. (Drive 11)**

This message is for the use case when an implementation has detected that an Array is Critical.

May also be shown as 806f050d040bffff or 0x806f050d040bffff

**Severity**

Error

**Serviceable**

Yes

**Automatically notify support**

No

**Alert Category**

Critical - Hard Disk drive

**SNMP Trap ID**

5

**CIM Information**

**Prefix:** PLAT ID: 0174

**User Response**

1. Make sure that the RAID adapter firmware and hard disk drive firmware are at the latest level.
  2. Make sure that the SAS cable is connected correctly.
  3. Replace the SAS cable.
  4. Check backplane cable connection.
  5. Replace the RAID adapter.
  6. Replace the hard disk drive that is indicated by a lit status LED.
- **806f050d-040cffff : Array [ComputerSystemElementName] is in critical condition. (Drive 12)**

This message is for the use case when an implementation has detected that an Array is Critical.

May also be shown as 806f050d040cffff or 0x806f050d040cffff

**Severity**

Error

**Serviceable**

Yes

**Automatically notify support**

No

**Alert Category**

Critical - Hard Disk drive

**SNMP Trap ID**

5

**CIM Information**

**Prefix: PLAT ID:** 0174

**User Response**

1. Make sure that the RAID adapter firmware and hard disk drive firmware are at the latest level.
  2. Make sure that the SAS cable is connected correctly.
  3. Replace the SAS cable.
  4. Check backplane cable connection.
  5. Replace the RAID adapter.
  6. Replace the hard disk drive that is indicated by a lit status LED.
- **806f050d-040dffff : Array [ComputerSystemElementName] is in critical condition. (Drive 13)**

This message is for the use case when an implementation has detected that an Array is Critical.

May also be shown as 806f050d040dffff or 0x806f050d040dffff

**Severity**

Error

**Serviceable**

Yes

**Automatically notify support**

No

**Alert Category**

Critical - Hard Disk drive

**SNMP Trap ID**

5

**CIM Information**

**Prefix: PLAT ID:** 0174

**User Response**

1. Make sure that the RAID adapter firmware and hard disk drive firmware are at the latest level.
  2. Make sure that the SAS cable is connected correctly.
  3. Replace the SAS cable.
  4. Check backplane cable connection.
  5. Replace the RAID adapter.
  6. Replace the hard disk drive that is indicated by a lit status LED.
- **806f050d-040effff : Array [ComputerSystemElementName] is in critical condition. (Drive 14)**

This message is for the use case when an implementation has detected that an Array is Critical.

May also be shown as 806f050d040effff or 0x806f050d040effff

**Severity**

Error

**Serviceable**

Yes

**Automatically notify support**

No

**Alert Category**

Critical - Hard Disk drive

**SNMP Trap ID**

5

**CIM Information**

**Prefix: PLAT ID:** 0174

**User Response**

1. Make sure that the RAID adapter firmware and hard disk drive firmware are at the latest level.
  2. Make sure that the SAS cable is connected correctly.
  3. Replace the SAS cable.
  4. Check backplane cable connection.
  5. Replace the RAID adapter.
  6. Replace the hard disk drive that is indicated by a lit status LED.
- **806f050d-040ffff : Array [ComputerSystemElementName] is in critical condition. (Drive 15)**

This message is for the use case when an implementation has detected that an Array is Critical.

May also be shown as 806f050d040ffff or 0x806f050d040ffff

**Severity**

Error

**Serviceable**

Yes

**Automatically notify support**

No

**Alert Category**

Critical - Hard Disk drive

**SNMP Trap ID**

5

**CIM Information**

**Prefix: PLAT ID:** 0174

**User Response**

1. Make sure that the RAID adapter firmware and hard disk drive firmware are at the latest level.
  2. Make sure that the SAS cable is connected correctly.
  3. Replace the SAS cable.
  4. Check backplane cable connection.
  5. Replace the RAID adapter.
  6. Replace the hard disk drive that is indicated by a lit status LED.
- **806f050d-0410ffff : Array [ComputerSystemElementName] is in critical condition. (Drive 16)**

This message is for the use case when an implementation has detected that an Array is Critical.

May also be shown as 806f050d0410ffff or 0x806f050d0410ffff

**Severity**

Error

**Serviceable**

Yes

**Automatically notify support**

No

**Alert Category**

Critical - Hard Disk drive

**SNMP Trap ID**

5

**CIM Information**

**Prefix: PLAT ID:** 0174

**User Response**

1. Make sure that the RAID adapter firmware and hard disk drive firmware are at the latest level.
  2. Make sure that the SAS cable is connected correctly.
  3. Replace the SAS cable.
  4. Check backplane cable connection.
  5. Replace the RAID adapter.
  6. Replace the hard disk drive that is indicated by a lit status LED.
- **806f050d-0411ffff : Array [ComputerSystemElementName] is in critical condition. (Drive 17)**

This message is for the use case when an implementation has detected that an Array is Critical.

May also be shown as 806f050d0411ffff or 0x806f050d0411ffff

**Severity**

Error

**Serviceable**

Yes

**Automatically notify support**

No

**Alert Category**

Critical - Hard Disk drive

**SNMP Trap ID**

5

**CIM Information**

**Prefix: PLAT ID:** 0174

**User Response**

1. Make sure that the RAID adapter firmware and hard disk drive firmware are at the latest level.
2. Make sure that the SAS cable is connected correctly.
3. Replace the SAS cable.
4. Check backplane cable connection.
5. Replace the RAID adapter.
6. Replace the hard disk drive that is indicated by a lit status LED.

- **806f050d-0412ffff : Array [ComputerSystemElementName] is in critical condition. (Drive 18)**

This message is for the use case when an implementation has detected that an Array is Critical.

May also be shown as 806f050d0412ffff or 0x806f050d0412ffff

**Severity**

Error

**Serviceable**

Yes

**Automatically notify support**

No

**Alert Category**

Critical - Hard Disk drive

**SNMP Trap ID**

5

**CIM Information**

**Prefix:** PLAT ID: 0174

**User Response**

1. Make sure that the RAID adapter firmware and hard disk drive firmware are at the latest level.
2. Make sure that the SAS cable is connected correctly.
3. Replace the SAS cable.
4. Check backplane cable connection.
5. Replace the RAID adapter.
6. Replace the hard disk drive that is indicated by a lit status LED.

- **806f050d-0413ffff : Array [ComputerSystemElementName] is in critical condition. (Drive 19)**

This message is for the use case when an implementation has detected that an Array is Critical.

May also be shown as 806f050d0413ffff or 0x806f050d0413ffff

**Severity**

Error

**Serviceable**

Yes

**Automatically notify support**

No

**Alert Category**

Critical - Hard Disk drive

**SNMP Trap ID**

5

**CIM Information**

**Prefix:** PLAT ID: 0174

**User Response**

1. Make sure that the RAID adapter firmware and hard disk drive firmware are at the latest level.
2. Make sure that the SAS cable is connected correctly.
3. Replace the SAS cable.
4. Check backplane cable connection.

5. Replace the RAID adapter.
6. Replace the hard disk drive that is indicated by a lit status LED.

- **806f050d-0414ffff : Array [ComputerSystemElementName] is in critical condition. (Drive 20)**

This message is for the use case when an implementation has detected that an Array is Critical.

May also be shown as 806f050d0414ffff or 0x806f050d0414ffff

**Severity**

Error

**Serviceable**

Yes

**Automatically notify support**

No

**Alert Category**

Critical - Hard Disk drive

**SNMP Trap ID**

5

**CIM Information**

**Prefix: PLAT ID:** 0174

**User Response**

1. Make sure that the RAID adapter firmware and hard disk drive firmware are at the latest level.
2. Make sure that the SAS cable is connected correctly.
3. Replace the SAS cable.
4. Check backplane cable connection.
5. Replace the RAID adapter.
6. Replace the hard disk drive that is indicated by a lit status LED.

- **806f050d-0415ffff : Array [ComputerSystemElementName] is in critical condition. (Drive 21)**

This message is for the use case when an implementation has detected that an Array is Critical.

May also be shown as 806f050d0415ffff or 0x806f050d0415ffff

**Severity**

Error

**Serviceable**

Yes

**Automatically notify support**

No

**Alert Category**

Critical - Hard Disk drive

**SNMP Trap ID**

5

**CIM Information**

**Prefix: PLAT ID:** 0174

**User Response**

1. Make sure that the RAID adapter firmware and hard disk drive firmware are at the latest level.
2. Make sure that the SAS cable is connected correctly.

3. Replace the SAS cable.
  4. Check backplane cable connection.
  5. Replace the RAID adapter.
  6. Replace the hard disk drive that is indicated by a lit status LED.
- **806f050d-0416ffff : Array [ComputerSystemElementName] is in critical condition. (Drive 22)**

This message is for the use case when an implementation has detected that an Array is Critical.

May also be shown as 806f050d0416ffff or 0x806f050d0416ffff

**Severity**

Error

**Serviceable**

Yes

**Automatically notify support**

No

**Alert Category**

Critical - Hard Disk drive

**SNMP Trap ID**

5

**CIM Information**

**Prefix:** PLAT ID: 0174

**User Response**

1. Make sure that the RAID adapter firmware and hard disk drive firmware are at the latest level.
2. Make sure that the SAS cable is connected correctly.
3. Replace the SAS cable.
4. Check backplane cable connection.
5. Replace the RAID adapter.
6. Replace the hard disk drive that is indicated by a lit status LED.

- **806f050d-0417ffff : Array [ComputerSystemElementName] is in critical condition. (Drive 23)**

This message is for the use case when an implementation has detected that an Array is Critical.

May also be shown as 806f050d0417ffff or 0x806f050d0417ffff

**Severity**

Error

**Serviceable**

Yes

**Automatically notify support**

No

**Alert Category**

Critical - Hard Disk drive

**SNMP Trap ID**

5

**CIM Information**

**Prefix:** PLAT ID: 0174

**User Response**

1. Make sure that the RAID adapter firmware and hard disk drive firmware are at the latest level.
  2. Make sure that the SAS cable is connected correctly.
  3. Replace the SAS cable.
  4. Check backplane cable connection.
  5. Replace the RAID adapter.
  6. Replace the hard disk drive that is indicated by a lit status LED.
- **806f050d-0418ffff : Array [ComputerSystemElementName] is in critical condition. (Drive 24)**  
This message is for the use case when an implementation has detected that an Array is Critical.  
May also be shown as 806f050d0418ffff or 0x806f050d0418ffff

**Severity**

Error

**Serviceable**

Yes

**Automatically notify support**

No

**Alert Category**

Critical - Hard Disk drive

**SNMP Trap ID**

5

**CIM Information**

Prefix: PLAT ID: 0174

**User Response**

1. Make sure that the RAID adapter firmware and hard disk drive firmware are at the latest level.
  2. Make sure that the SAS cable is connected correctly.
  3. Replace the SAS cable.
  4. Check backplane cable connection.
  5. Replace the RAID adapter.
  6. Replace the hard disk drive that is indicated by a lit status LED.
- **806f050d-0419ffff : Array [ComputerSystemElementName] is in critical condition. (Drive 25)**  
This message is for the use case when an implementation has detected that an Array is Critical.  
May also be shown as 806f050d0419ffff or 0x806f050d0419ffff

**Severity**

Error

**Serviceable**

Yes

**Automatically notify support**

No

**Alert Category**

Critical - Hard Disk drive

**SNMP Trap ID**

5

**CIM Information**



**Prefix: PLAT ID:** 0174

**User Response**

1. Make sure that the RAID adapter firmware and hard disk drive firmware are at the latest level.
  2. Make sure that the SAS cable is connected correctly.
  3. Replace the SAS cable.
  4. Check backplane cable connection.
  5. Replace the RAID adapter.
  6. Replace the hard disk drive that is indicated by a lit status LED.
- **806f050d-041affff : Array [ComputerSystemElementName] is in critical condition. (Drive 26)**

This message is for the use case when an implementation has detected that an Array is Critical.

May also be shown as 806f050d041affff or 0x806f050d041affff

**Severity**

Error

**Serviceable**

Yes

**Automatically notify support**

No

**Alert Category**

Critical - Hard Disk drive

**SNMP Trap ID**

5

**CIM Information**

**Prefix: PLAT ID:** 0174

**User Response**

1. Make sure that the RAID adapter firmware and hard disk drive firmware are at the latest level.
  2. Make sure that the SAS cable is connected correctly.
  3. Replace the SAS cable.
  4. Check backplane cable connection.
  5. Replace the RAID adapter.
  6. Replace the hard disk drive that is indicated by a lit status LED.
- **806f050d-041bffff : Array [ComputerSystemElementName] is in critical condition. (Drive 27)**

This message is for the use case when an implementation has detected that an Array is Critical.

May also be shown as 806f050d041bffff or 0x806f050d041bffff

**Severity**

Error

**Serviceable**

Yes

**Automatically notify support**

No

**Alert Category**

Critical - Hard Disk drive

**SNMP Trap ID**

**CIM Information**

Prefix: PLAT ID: 0174

**User Response**

1. Make sure that the RAID adapter firmware and hard disk drive firmware are at the latest level.
  2. Make sure that the SAS cable is connected correctly.
  3. Replace the SAS cable.
  4. Check backplane cable connection.
  5. Replace the RAID adapter.
  6. Replace the hard disk drive that is indicated by a lit status LED.
- **806f050d-041cffff : Array [ComputerSystemElementName] is in critical condition. (Drive 28)**

This message is for the use case when an implementation has detected that an Array is Critical.

May also be shown as 806f050d041cffff or 0x806f050d041cffff

**Severity**

Error

**Serviceable**

Yes

**Automatically notify support**

No

**Alert Category**

Critical - Hard Disk drive

**SNMP Trap ID**

5

**CIM Information**

Prefix: PLAT ID: 0174

**User Response**

1. Make sure that the RAID adapter firmware and hard disk drive firmware are at the latest level.
  2. Make sure that the SAS cable is connected correctly.
  3. Replace the SAS cable.
  4. Check backplane cable connection.
  5. Replace the RAID adapter.
  6. Replace the hard disk drive that is indicated by a lit status LED.
- **806f050d-041dffff : Array [ComputerSystemElementName] is in critical condition. (Drive 29)**

This message is for the use case when an implementation has detected that an Array is Critical.

May also be shown as 806f050d041dffff or 0x806f050d041dffff

**Severity**

Error

**Serviceable**

Yes

**Automatically notify support**

No

**Alert Category**

Critical - Hard Disk drive

**SNMP Trap ID**

5

**CIM Information**

**Prefix:** PLAT ID: 0174

**User Response**

1. Make sure that the RAID adapter firmware and hard disk drive firmware are at the latest level.
  2. Make sure that the SAS cable is connected correctly.
  3. Replace the SAS cable.
  4. Check backplane cable connection.
  5. Replace the RAID adapter.
  6. Replace the hard disk drive that is indicated by a lit status LED.
- **806f050d-041effff : Array [ComputerSystemElementName] is in critical condition. (Drive 30)**

This message is for the use case when an implementation has detected that an Array is Critical.

May also be shown as 806f050d041effff or 0x806f050d041effff

**Severity**

Error

**Serviceable**

Yes

**Automatically notify support**

No

**Alert Category**

Critical - Hard Disk drive

**SNMP Trap ID**

5

**CIM Information**

**Prefix:** PLAT ID: 0174

**User Response**

1. Make sure that the RAID adapter firmware and hard disk drive firmware are at the latest level.
  2. Make sure that the SAS cable is connected correctly.
  3. Replace the SAS cable.
  4. Check backplane cable connection.
  5. Replace the RAID adapter.
  6. Replace the hard disk drive that is indicated by a lit status LED.
- **806f050d-041ffff : Array [ComputerSystemElementName] is in critical condition. (Drive 31)**

This message is for the use case when an implementation has detected that an Array is Critical.

May also be shown as 806f050d041ffff or 0x806f050d041ffff

**Severity**

Error

**Serviceable**

Yes

**Automatically notify support**

No

**Alert Category**

Critical - Hard Disk drive

**SNMP Trap ID**

5

**CIM Information**

**Prefix:** PLAT ID: 0174

**User Response**

1. Make sure that the RAID adapter firmware and hard disk drive firmware are at the latest level.
  2. Make sure that the SAS cable is connected correctly.
  3. Replace the SAS cable.
  4. Check backplane cable connection.
  5. Replace the RAID adapter.
  6. Replace the hard disk drive that is indicated by a lit status LED.
- **806f050d-0420ffff : Array [ComputerSystemElementName] is in critical condition. (Ext Drive)**

This message is for the use case when an implementation has detected that an Array is Critical.

May also be shown as 806f050d0420ffff or 0x806f050d0420ffff

**Severity**

Error

**Serviceable**

Yes

**Automatically notify support**

No

**Alert Category**

Critical - Hard Disk drive

**SNMP Trap ID**

5

**CIM Information**

**Prefix:** PLAT ID: 0174

**User Response**

1. Make sure that the RAID adapter firmware and hard disk drive firmware are at the latest level.
  2. Make sure that the SAS cable is connected correctly.
  3. Replace the SAS cable.
  4. Check backplane cable connection.
  5. Replace the RAID adapter.
  6. Replace the hard disk drive that is indicated by a lit status LED.
- **806f0513-2582ffff : A PCI SERR has occurred on system [ComputerSystemElementName]. (PCIs)**

This message is for the use case when an implementation has detected a PCI SERR.

May also be shown as 806f05132582ffff or 0x806f05132582ffff

**Severity**

Error

**Serviceable**

Yes

**Automatically notify support**

No

**Alert Category**

Critical - Other

**SNMP Trap ID**

50

**CIM Information**

**Prefix:** PLAT ID: 0234

**User Response**

1. Check the PCI LED.
  2. Reseat the affected adapters and riser card.
  3. Update the server firmware (UEFI and IMM) and adapter firmware. Important: Some cluster solutions require specific code levels or coordinated code updates. If the device is part of a cluster solution, verify that the latest level of code is supported for the cluster solution before you update the code.
  4. Make sure that the adapter is supported. For a list of supported optional devices, see <http://www.lenovo.com/serverproven/>.
  5. Remove both adapters.
  6. Replace the PCIe adapters.
  7. Replace the riser card.
- **806f052b-2101ffff : Invalid or Unsupported firmware or software was detected on system [ComputerSystemElementName]. (IMM2 FW Failover)**

This message is for the use case when an implementation has detected an Invalid/Unsupported Firmware/Software Version.

May also be shown as 806f052b2101ffff or 0x806f052b2101ffff

**Severity**

Error

**Serviceable**

Yes

**Automatically notify support**

No

**Alert Category**

Critical - Other

**SNMP Trap ID**

50

**CIM Information**

**Prefix:** PLAT ID: 0446

**User Response**

1. Make sure the server meets the minimum configuration to start (see Power-supply LEDs).
2. Recover the server firmware from the backup page by restarting the server.
3. Update the server firmware to the latest level (see Updating the firmware). Important: Some cluster solutions require specific code levels or coordinated code updates. If the device is part of

a cluster solution, verify that the latest level of code is supported for the cluster solution before you update the code.

4. Remove components one at a time, restarting the server each time, to see if the problem goes away.
  5. If the problem remains, (trained service technician) replace the system board.
- **806f0607-0301ffff : An SM BIOS Uncorrectable CPU complex error for [ProcessorElementName] has asserted. (CPU 1)**

This message is for the use case when an SM BIOS Uncorrectable CPU complex error has asserted.

May also be shown as 806f06070301ffff or 0x806f06070301ffff

**Severity**

Error

**Serviceable**

Yes

**Automatically notify support**

No

**Alert Category**

Critical - CPU

**SNMP Trap ID**

40

**CIM Information**

**Prefix: PLAT ID: 0816**

**User Response**

1. Make sure that the installed microprocessors are compatible with each other (see Installing a microprocessor and heat sink for information about microprocessor requirements).
  2. Update the server firmware to the latest level (see Updating the firmware).
  3. (Trained technician only) Replace the incompatible microprocessor.
- **806f0607-0302ffff : An SM BIOS Uncorrectable CPU complex error for [ProcessorElementName] has asserted. (CPU 2)**

This message is for the use case when an SM BIOS Uncorrectable CPU complex error has asserted.

May also be shown as 806f06070302ffff or 0x806f06070302ffff

**Severity**

Error

**Serviceable**

Yes

**Automatically notify support**

No

**Alert Category**

Critical - CPU

**SNMP Trap ID**

40

**CIM Information**

**Prefix: PLAT ID: 0816**

**User Response**

1. Make sure that the installed microprocessors are compatible with each other (see Installing a microprocessor and heat sink for information about microprocessor requirements).
  2. Update the server firmware to the latest level (see Updating the firmware).
  3. (Trained technician only) Replace the incompatible microprocessor.
- **806f0607-2584ffff : An SM BIOS Uncorrectable CPU complex error for [ProcessorElementName] has asserted. (All CPUs)**

This message is for the use case when an SM BIOS Uncorrectable CPU complex error has asserted.

May also be shown as 806f06072584ffff or 0x806f06072584ffff

**Severity**

Error

**Serviceable**

Yes

**Automatically notify support**

No

**Alert Category**

Critical - CPU

**SNMP Trap ID**

40

**CIM Information**

Prefix: PLAT ID: 0816

**User Response**

1. Make sure that the installed microprocessors are compatible with each other (see Installing a microprocessor and heat sink for information about microprocessor requirements).
2. Update the server firmware to the latest level (see Updating the firmware).
3. (Trained technician only) Replace the incompatible microprocessor.

One of the CPUs :

- **806f0608-1301ffff : [PowerSupplyElementName] has a Configuration Mismatch. (PS Configuration)**

This message is for the use case when an implementation has detected a Power Supply with a Configuration Error.

May also be shown as 806f06081301ffff or 0x806f06081301ffff

**Severity**

Error

**Serviceable**

Yes

**Automatically notify support**

No

**Alert Category**

Critical - Power

**SNMP Trap ID**

4

**CIM Information**

Prefix: PLAT ID: 0104

**User Response**

1. Make sure that the power supplies installed are with the same rating or wattage.
  2. Reinstall the power supplies with the same rating or wattage.
- **806f060d-0400ffff : Array [ComputerSystemElementName] has failed. (Drive 0)**  
This message is for the use case when an implementation has detected that an Array Failed.  
May also be shown as 806f060d0400ffff or 0x806f060d0400ffff

**Severity**

Error

**Serviceable**

Yes

**Automatically notify support**

Yes

**Alert Category**

Critical - Hard Disk drive

**SNMP Trap ID**

5

**CIM Information**

**Prefix: PLAT ID:** 0176

**User Response**

1. Make sure that the RAID adapter firmware and hard disk drive firmware are at the latest level.
  2. Make sure that the SAS cable is connected correctly.
  3. Replace the SAS cable.
  4. Replace the RAID adapter.
  5. Replace the hard disk drive that is indicated by a lit status LED.
- **806f060d-0401ffff : Array [ComputerSystemElementName] has failed. (Drive 1)**  
This message is for the use case when an implementation has detected that an Array Failed.  
May also be shown as 806f060d0401ffff or 0x806f060d0401ffff

**Severity**

Error

**Serviceable**

Yes

**Automatically notify support**

Yes

**Alert Category**

Critical - Hard Disk drive

**SNMP Trap ID**

5

**CIM Information**

**Prefix: PLAT ID:** 0176

**User Response**

1. Make sure that the RAID adapter firmware and hard disk drive firmware are at the latest level.
2. Make sure that the SAS cable is connected correctly.
3. Replace the SAS cable.



4. Replace the RAID adapter.
5. Replace the hard disk drive that is indicated by a lit status LED.

- **806f060d-0402ffff : Array [ComputerSystemElementName] has failed. (Drive 2)**

This message is for the use case when an implementation has detected that an Array Failed.

May also be shown as 806f060d0402ffff or 0x806f060d0402ffff

**Severity**

Error

**Serviceable**

Yes

**Automatically notify support**

Yes

**Alert Category**

Critical - Hard Disk drive

**SNMP Trap ID**

5

**CIM Information**

**Prefix: PLAT ID:** 0176

**User Response**

1. Make sure that the RAID adapter firmware and hard disk drive firmware are at the latest level.
2. Make sure that the SAS cable is connected correctly.
3. Replace the SAS cable.
4. Replace the RAID adapter.
5. Replace the hard disk drive that is indicated by a lit status LED.

- **806f060d-0403ffff : Array [ComputerSystemElementName] has failed. (Drive 3)**

This message is for the use case when an implementation has detected that an Array Failed.

May also be shown as 806f060d0403ffff or 0x806f060d0403ffff

**Severity**

Error

**Serviceable**

Yes

**Automatically notify support**

Yes

**Alert Category**

Critical - Hard Disk drive

**SNMP Trap ID**

5

**CIM Information**

**Prefix: PLAT ID:** 0176

**User Response**

1. Make sure that the RAID adapter firmware and hard disk drive firmware are at the latest level.
2. Make sure that the SAS cable is connected correctly.
3. Replace the SAS cable.

4. Replace the RAID adapter.
5. Replace the hard disk drive that is indicated by a lit status LED.

- **806f060d-0404ffff : Array [ComputerSystemElementName] has failed. (Drive 4)**

This message is for the use case when an implementation has detected that an Array Failed.

May also be shown as 806f060d0404ffff or 0x806f060d0404ffff

**Severity**

Error

**Serviceable**

Yes

**Automatically notify support**

Yes

**Alert Category**

Critical - Hard Disk drive

**SNMP Trap ID**

5

**CIM Information**

**Prefix: PLAT ID:** 0176

**User Response**

1. Make sure that the RAID adapter firmware and hard disk drive firmware are at the latest level.
2. Make sure that the SAS cable is connected correctly.
3. Replace the SAS cable.
4. Replace the RAID adapter.
5. Replace the hard disk drive that is indicated by a lit status LED.

- **806f060d-0405ffff : Array [ComputerSystemElementName] has failed. (Drive 5)**

This message is for the use case when an implementation has detected that an Array Failed.

May also be shown as 806f060d0405ffff or 0x806f060d0405ffff

**Severity**

Error

**Serviceable**

Yes

**Automatically notify support**

Yes

**Alert Category**

Critical - Hard Disk drive

**SNMP Trap ID**

5

**CIM Information**

**Prefix: PLAT ID:** 0176

**User Response**

1. Make sure that the RAID adapter firmware and hard disk drive firmware are at the latest level.
2. Make sure that the SAS cable is connected correctly.
3. Replace the SAS cable.

4. Replace the RAID adapter.
5. Replace the hard disk drive that is indicated by a lit status LED.

- **806f060d-0406ffff : Array [ComputerSystemElementName] has failed. (Drive 6)**

This message is for the use case when an implementation has detected that an Array Failed.

May also be shown as 806f060d0406ffff or 0x806f060d0406ffff

**Severity**

Error

**Serviceable**

Yes

**Automatically notify support**

Yes

**Alert Category**

Critical - Hard Disk drive

**SNMP Trap ID**

5

**CIM Information**

**Prefix:** PLAT ID: 0176

**User Response**

1. Make sure that the RAID adapter firmware and hard disk drive firmware are at the latest level.
2. Make sure that the SAS cable is connected correctly.
3. Replace the SAS cable.
4. Replace the RAID adapter.
5. Replace the hard disk drive that is indicated by a lit status LED.

- **806f060d-0407ffff : Array [ComputerSystemElementName] has failed. (Drive 7)**

This message is for the use case when an implementation has detected that an Array Failed.

May also be shown as 806f060d0407ffff or 0x806f060d0407ffff

**Severity**

Error

**Serviceable**

Yes

**Automatically notify support**

Yes

**Alert Category**

Critical - Hard Disk drive

**SNMP Trap ID**

5

**CIM Information**

**Prefix:** PLAT ID: 0176

**User Response**

1. Make sure that the RAID adapter firmware and hard disk drive firmware are at the latest level.
2. Make sure that the SAS cable is connected correctly.
3. Replace the SAS cable.

4. Replace the RAID adapter.
5. Replace the hard disk drive that is indicated by a lit status LED.

- **806f060d-0408ffff : Array [ComputerSystemElementName] has failed. (Drive 8)**

This message is for the use case when an implementation has detected that an Array Failed.

May also be shown as 806f060d0408ffff or 0x806f060d0408ffff

**Severity**

Error

**Serviceable**

Yes

**Automatically notify support**

Yes

**Alert Category**

Critical - Hard Disk drive

**SNMP Trap ID**

5

**CIM Information**

**Prefix: PLAT ID:** 0176

**User Response**

1. Make sure that the RAID adapter firmware and hard disk drive firmware are at the latest level.
2. Make sure that the SAS cable is connected correctly.
3. Replace the SAS cable.
4. Replace the RAID adapter.
5. Replace the hard disk drive that is indicated by a lit status LED.

- **806f060d-0409ffff : Array [ComputerSystemElementName] has failed. (Drive 9)**

This message is for the use case when an implementation has detected that an Array Failed.

May also be shown as 806f060d0409ffff or 0x806f060d0409ffff

**Severity**

Error

**Serviceable**

Yes

**Automatically notify support**

Yes

**Alert Category**

Critical - Hard Disk drive

**SNMP Trap ID**

5

**CIM Information**

**Prefix: PLAT ID:** 0176

**User Response**

1. Make sure that the RAID adapter firmware and hard disk drive firmware are at the latest level.
2. Make sure that the SAS cable is connected correctly.
3. Replace the SAS cable.

4. Replace the RAID adapter.
5. Replace the hard disk drive that is indicated by a lit status LED.

- **806f060d-040affff : Array [ComputerSystemElementName] has failed. (Drive 10)**

This message is for the use case when an implementation has detected that an Array Failed.

May also be shown as 806f060d040affff or 0x806f060d040affff

**Severity**

Error

**Serviceable**

Yes

**Automatically notify support**

Yes

**Alert Category**

Critical - Hard Disk drive

**SNMP Trap ID**

5

**CIM Information**

**Prefix: PLAT ID:** 0176

**User Response**

1. Make sure that the RAID adapter firmware and hard disk drive firmware are at the latest level.
2. Make sure that the SAS cable is connected correctly.
3. Replace the SAS cable.
4. Replace the RAID adapter.
5. Replace the hard disk drive that is indicated by a lit status LED.

- **806f060d-040bffff : Array [ComputerSystemElementName] has failed. (Drive 11)**

This message is for the use case when an implementation has detected that an Array Failed.

May also be shown as 806f060d040bffff or 0x806f060d040bffff

**Severity**

Error

**Serviceable**

Yes

**Automatically notify support**

Yes

**Alert Category**

Critical - Hard Disk drive

**SNMP Trap ID**

5

**CIM Information**

**Prefix: PLAT ID:** 0176

**User Response**

1. Make sure that the RAID adapter firmware and hard disk drive firmware are at the latest level.
2. Make sure that the SAS cable is connected correctly.
3. Replace the SAS cable.

4. Replace the RAID adapter.
5. Replace the hard disk drive that is indicated by a lit status LED.

- **806f060d-040cffff : Array [ComputerSystemElementName] has failed. (Drive 12)**

This message is for the use case when an implementation has detected that an Array Failed.

May also be shown as 806f060d040cffff or 0x806f060d040cffff

**Severity**

Error

**Serviceable**

Yes

**Automatically notify support**

Yes

**Alert Category**

Critical - Hard Disk drive

**SNMP Trap ID**

5

**CIM Information**

**Prefix: PLAT ID:** 0176

**User Response**

1. Make sure that the RAID adapter firmware and hard disk drive firmware are at the latest level.
2. Make sure that the SAS cable is connected correctly.
3. Replace the SAS cable.
4. Replace the RAID adapter.
5. Replace the hard disk drive that is indicated by a lit status LED.

- **806f060d-040dffff : Array [ComputerSystemElementName] has failed. (Drive 13)**

This message is for the use case when an implementation has detected that an Array Failed.

May also be shown as 806f060d040dffff or 0x806f060d040dffff

**Severity**

Error

**Serviceable**

Yes

**Automatically notify support**

Yes

**Alert Category**

Critical - Hard Disk drive

**SNMP Trap ID**

5

**CIM Information**

**Prefix: PLAT ID:** 0176

**User Response**

1. Make sure that the RAID adapter firmware and hard disk drive firmware are at the latest level.
2. Make sure that the SAS cable is connected correctly.
3. Replace the SAS cable.

4. Replace the RAID adapter.
5. Replace the hard disk drive that is indicated by a lit status LED.

- **806f060d-040effff : Array [ComputerSystemElementName] has failed. (Drive 14)**

This message is for the use case when an implementation has detected that an Array Failed.

May also be shown as 806f060d040effff or 0x806f060d040effff

**Severity**

Error

**Serviceable**

Yes

**Automatically notify support**

Yes

**Alert Category**

Critical - Hard Disk drive

**SNMP Trap ID**

5

**CIM Information**

**Prefix:** PLAT ID: 0176

**User Response**

1. Make sure that the RAID adapter firmware and hard disk drive firmware are at the latest level.
2. Make sure that the SAS cable is connected correctly.
3. Replace the SAS cable.
4. Replace the RAID adapter.
5. Replace the hard disk drive that is indicated by a lit status LED.

- **806f060d-040fffff : Array [ComputerSystemElementName] has failed. (Drive 15)**

This message is for the use case when an implementation has detected that an Array Failed.

May also be shown as 806f060d040fffff or 0x806f060d040fffff

**Severity**

Error

**Serviceable**

Yes

**Automatically notify support**

Yes

**Alert Category**

Critical - Hard Disk drive

**SNMP Trap ID**

5

**CIM Information**

**Prefix:** PLAT ID: 0176

**User Response**

1. Make sure that the RAID adapter firmware and hard disk drive firmware are at the latest level.
2. Make sure that the SAS cable is connected correctly.
3. Replace the SAS cable.

4. Replace the RAID adapter.
5. Replace the hard disk drive that is indicated by a lit status LED.

- **806f060d-0410ffff : Array [ComputerSystemElementName] has failed. (Drive 16)**

This message is for the use case when an implementation has detected that an Array Failed.

May also be shown as 806f060d0410ffff or 0x806f060d0410ffff

**Severity**

Error

**Serviceable**

Yes

**Automatically notify support**

Yes

**Alert Category**

Critical - Hard Disk drive

**SNMP Trap ID**

5

**CIM Information**

**Prefix: PLAT ID:** 0176

**User Response**

1. Make sure that the RAID adapter firmware and hard disk drive firmware are at the latest level.
2. Make sure that the SAS cable is connected correctly.
3. Replace the SAS cable.
4. Replace the RAID adapter.
5. Replace the hard disk drive that is indicated by a lit status LED.

- **806f060d-0411ffff : Array [ComputerSystemElementName] has failed. (Drive 17)**

This message is for the use case when an implementation has detected that an Array Failed.

May also be shown as 806f060d0411ffff or 0x806f060d0411ffff

**Severity**

Error

**Serviceable**

Yes

**Automatically notify support**

Yes

**Alert Category**

Critical - Hard Disk drive

**SNMP Trap ID**

5

**CIM Information**

**Prefix: PLAT ID:** 0176

**User Response**

1. Make sure that the RAID adapter firmware and hard disk drive firmware are at the latest level.
2. Make sure that the SAS cable is connected correctly.
3. Replace the SAS cable.



4. Replace the RAID adapter.
5. Replace the hard disk drive that is indicated by a lit status LED.

- **806f060d-0412ffff : Array [ComputerSystemElementName] has failed. (Drive 18)**

This message is for the use case when an implementation has detected that an Array Failed.

May also be shown as 806f060d0412ffff or 0x806f060d0412ffff

**Severity**

Error

**Serviceable**

Yes

**Automatically notify support**

Yes

**Alert Category**

Critical - Hard Disk drive

**SNMP Trap ID**

5

**CIM Information**

**Prefix:** PLAT ID: 0176

**User Response**

1. Make sure that the RAID adapter firmware and hard disk drive firmware are at the latest level.
2. Make sure that the SAS cable is connected correctly.
3. Replace the SAS cable.
4. Replace the RAID adapter.
5. Replace the hard disk drive that is indicated by a lit status LED.

- **806f060d-0413ffff : Array [ComputerSystemElementName] has failed. (Drive 19)**

This message is for the use case when an implementation has detected that an Array Failed.

May also be shown as 806f060d0413ffff or 0x806f060d0413ffff

**Severity**

Error

**Serviceable**

Yes

**Automatically notify support**

Yes

**Alert Category**

Critical - Hard Disk drive

**SNMP Trap ID**

5

**CIM Information**

**Prefix:** PLAT ID: 0176

**User Response**

1. Make sure that the RAID adapter firmware and hard disk drive firmware are at the latest level.
2. Make sure that the SAS cable is connected correctly.
3. Replace the SAS cable.

4. Replace the RAID adapter.
5. Replace the hard disk drive that is indicated by a lit status LED.

- **806f060d-0414ffff : Array [ComputerSystemElementName] has failed. (Drive 20)**

This message is for the use case when an implementation has detected that an Array Failed.

May also be shown as 806f060d0414ffff or 0x806f060d0414ffff

**Severity**

Error

**Serviceable**

Yes

**Automatically notify support**

Yes

**Alert Category**

Critical - Hard Disk drive

**SNMP Trap ID**

5

**CIM Information**

**Prefix: PLAT ID:** 0176

**User Response**

1. Make sure that the RAID adapter firmware and hard disk drive firmware are at the latest level.
2. Make sure that the SAS cable is connected correctly.
3. Replace the SAS cable.
4. Replace the RAID adapter.
5. Replace the hard disk drive that is indicated by a lit status LED.

- **806f060d-0415ffff : Array [ComputerSystemElementName] has failed. (Drive 21)**

This message is for the use case when an implementation has detected that an Array Failed.

May also be shown as 806f060d0415ffff or 0x806f060d0415ffff

**Severity**

Error

**Serviceable**

Yes

**Automatically notify support**

Yes

**Alert Category**

Critical - Hard Disk drive

**SNMP Trap ID**

5

**CIM Information**

**Prefix: PLAT ID:** 0176

**User Response**

1. Make sure that the RAID adapter firmware and hard disk drive firmware are at the latest level.
2. Make sure that the SAS cable is connected correctly.
3. Replace the SAS cable.

4. Replace the RAID adapter.
5. Replace the hard disk drive that is indicated by a lit status LED.

- **806f060d-0416ffff : Array [ComputerSystemElementName] has failed. (Drive 22)**

This message is for the use case when an implementation has detected that an Array Failed.

May also be shown as 806f060d0416ffff or 0x806f060d0416ffff

**Severity**

Error

**Serviceable**

Yes

**Automatically notify support**

Yes

**Alert Category**

Critical - Hard Disk drive

**SNMP Trap ID**

5

**CIM Information**

**Prefix:** PLAT ID: 0176

**User Response**

1. Make sure that the RAID adapter firmware and hard disk drive firmware are at the latest level.
2. Make sure that the SAS cable is connected correctly.
3. Replace the SAS cable.
4. Replace the RAID adapter.
5. Replace the hard disk drive that is indicated by a lit status LED.

- **806f060d-0417ffff : Array [ComputerSystemElementName] has failed. (Drive 23)**

This message is for the use case when an implementation has detected that an Array Failed.

May also be shown as 806f060d0417ffff or 0x806f060d0417ffff

**Severity**

Error

**Serviceable**

Yes

**Automatically notify support**

Yes

**Alert Category**

Critical - Hard Disk drive

**SNMP Trap ID**

5

**CIM Information**

**Prefix:** PLAT ID: 0176

**User Response**

1. Make sure that the RAID adapter firmware and hard disk drive firmware are at the latest level.
2. Make sure that the SAS cable is connected correctly.
3. Replace the SAS cable.

4. Replace the RAID adapter.
5. Replace the hard disk drive that is indicated by a lit status LED.

- **806f060d-0418ffff : Array [ComputerSystemElementName] has failed. (Drive 24)**

This message is for the use case when an implementation has detected that an Array Failed.

May also be shown as 806f060d0418ffff or 0x806f060d0418ffff

**Severity**

Error

**Serviceable**

Yes

**Automatically notify support**

Yes

**Alert Category**

Critical - Hard Disk drive

**SNMP Trap ID**

5

**CIM Information**

**Prefix: PLAT ID:** 0176

**User Response**

1. Make sure that the RAID adapter firmware and hard disk drive firmware are at the latest level.
2. Make sure that the SAS cable is connected correctly.
3. Replace the SAS cable.
4. Replace the RAID adapter.
5. Replace the hard disk drive that is indicated by a lit status LED.

- **806f060d-0419ffff : Array [ComputerSystemElementName] has failed. (Drive 25)**

This message is for the use case when an implementation has detected that an Array Failed.

May also be shown as 806f060d0419ffff or 0x806f060d0419ffff

**Severity**

Error

**Serviceable**

Yes

**Automatically notify support**

Yes

**Alert Category**

Critical - Hard Disk drive

**SNMP Trap ID**

5

**CIM Information**

**Prefix: PLAT ID:** 0176

**User Response**

1. Make sure that the RAID adapter firmware and hard disk drive firmware are at the latest level.
2. Make sure that the SAS cable is connected correctly.
3. Replace the SAS cable.

4. Replace the RAID adapter.
5. Replace the hard disk drive that is indicated by a lit status LED.

- **806f060d-041affff : Array [ComputerSystemElementName] has failed. (Drive 26)**

This message is for the use case when an implementation has detected that an Array Failed.

May also be shown as 806f060d041affff or 0x806f060d041affff

**Severity**

Error

**Serviceable**

Yes

**Automatically notify support**

Yes

**Alert Category**

Critical - Hard Disk drive

**SNMP Trap ID**

5

**CIM Information**

**Prefix: PLAT ID:** 0176

**User Response**

1. Make sure that the RAID adapter firmware and hard disk drive firmware are at the latest level.
2. Make sure that the SAS cable is connected correctly.
3. Replace the SAS cable.
4. Replace the RAID adapter.
5. Replace the hard disk drive that is indicated by a lit status LED.

- **806f060d-041bffff : Array [ComputerSystemElementName] has failed. (Drive 27)**

This message is for the use case when an implementation has detected that an Array Failed.

May also be shown as 806f060d041bffff or 0x806f060d041bffff

**Severity**

Error

**Serviceable**

Yes

**Automatically notify support**

Yes

**Alert Category**

Critical - Hard Disk drive

**SNMP Trap ID**

5

**CIM Information**

**Prefix: PLAT ID:** 0176

**User Response**

1. Make sure that the RAID adapter firmware and hard disk drive firmware are at the latest level.
2. Make sure that the SAS cable is connected correctly.
3. Replace the SAS cable.

4. Replace the RAID adapter.
5. Replace the hard disk drive that is indicated by a lit status LED.

- **806f060d-041cffff : Array [ComputerSystemElementName] has failed. (Drive 28)**

This message is for the use case when an implementation has detected that an Array Failed.

May also be shown as 806f060d041cffff or 0x806f060d041cffff

**Severity**

Error

**Serviceable**

Yes

**Automatically notify support**

Yes

**Alert Category**

Critical - Hard Disk drive

**SNMP Trap ID**

5

**CIM Information**

**Prefix: PLAT ID:** 0176

**User Response**

1. Make sure that the RAID adapter firmware and hard disk drive firmware are at the latest level.
2. Make sure that the SAS cable is connected correctly.
3. Replace the SAS cable.
4. Replace the RAID adapter.
5. Replace the hard disk drive that is indicated by a lit status LED.

- **806f060d-041dffff : Array [ComputerSystemElementName] has failed. (Drive 29)**

This message is for the use case when an implementation has detected that an Array Failed.

May also be shown as 806f060d041dffff or 0x806f060d041dffff

**Severity**

Error

**Serviceable**

Yes

**Automatically notify support**

Yes

**Alert Category**

Critical - Hard Disk drive

**SNMP Trap ID**

5

**CIM Information**

**Prefix: PLAT ID:** 0176

**User Response**

1. Make sure that the RAID adapter firmware and hard disk drive firmware are at the latest level.
2. Make sure that the SAS cable is connected correctly.
3. Replace the SAS cable.

4. Replace the RAID adapter.
5. Replace the hard disk drive that is indicated by a lit status LED.

- **806f060d-041efff : Array [ComputerSystemElementName] has failed. (Drive 30)**

This message is for the use case when an implementation has detected that an Array Failed.

May also be shown as 806f060d041efff or 0x806f060d041efff

**Severity**

Error

**Serviceable**

Yes

**Automatically notify support**

Yes

**Alert Category**

Critical - Hard Disk drive

**SNMP Trap ID**

5

**CIM Information**

**Prefix:** PLAT ID: 0176

**User Response**

1. Make sure that the RAID adapter firmware and hard disk drive firmware are at the latest level.
2. Make sure that the SAS cable is connected correctly.
3. Replace the SAS cable.
4. Replace the RAID adapter.
5. Replace the hard disk drive that is indicated by a lit status LED.

- **806f060d-041ffff : Array [ComputerSystemElementName] has failed. (Drive 31)**

This message is for the use case when an implementation has detected that an Array Failed.

May also be shown as 806f060d041ffff or 0x806f060d041ffff

**Severity**

Error

**Serviceable**

Yes

**Automatically notify support**

Yes

**Alert Category**

Critical - Hard Disk drive

**SNMP Trap ID**

5

**CIM Information**

**Prefix:** PLAT ID: 0176

**User Response**

1. Make sure that the RAID adapter firmware and hard disk drive firmware are at the latest level.
2. Make sure that the SAS cable is connected correctly.
3. Replace the SAS cable.

4. Replace the RAID adapter.
5. Replace the hard disk drive that is indicated by a lit status LED.

- **806f060d-0420ffff : Array [ComputerSystemElementName] has failed. (Ext Drive)**

This message is for the use case when an implementation has detected that an Array Failed.

May also be shown as 806f060d0420ffff or 0x806f060d0420ffff

**Severity**

Error

**Serviceable**

Yes

**Automatically notify support**

Yes

**Alert Category**

Critical - Hard Disk drive

**SNMP Trap ID**

5

**CIM Information**

**Prefix: PLAT ID:** 0176

**User Response**

1. Make sure that the RAID adapter firmware and hard disk drive firmware are at the latest level.
2. Make sure that the SAS cable is connected correctly.
3. Replace the SAS cable.
4. Replace the RAID adapter.
5. Replace the hard disk drive that is indicated by a lit status LED.

- **806f070c-2001ffff : Configuration Error for [PhysicalMemoryElementName] on Subsystem [MemoryElementName]. (DIMM 1)**

This message is for the use case when an implementation has detected a Memory DIMM configuration error has been corrected.

May also be shown as 806f070c2001ffff or 0x806f070c2001ffff

**Severity**

Error

**Serviceable**

Yes

**Automatically notify support**

No

**Alert Category**

Critical - Memory

**SNMP Trap ID**

41

**CIM Information**

**Prefix: PLAT ID:** 0126

**User Response**

Make sure that DIMMs are installed in the correct sequence and have the same size, type, speed, and technology.



- **806f070c-2002ffff : Configuration Error for [PhysicalMemoryElementName] on Subsystem [MemoryElementName]. (DIMM 2)**

This message is for the use case when an implementation has detected a Memory DIMM configuration error has been corrected.

May also be shown as 806f070c2002ffff or 0x806f070c2002ffff

**Severity**

Error

**Serviceable**

Yes

**Automatically notify support**

No

**Alert Category**

Critical - Memory

**SNMP Trap ID**

41

**CIM Information**

**Prefix: PLAT ID:** 0126

**User Response**

Make sure that DIMMs are installed in the correct sequence and have the same size, type, speed, and technology.

- **806f070c-2003ffff : Configuration Error for [PhysicalMemoryElementName] on Subsystem [MemoryElementName]. (DIMM 3)**

This message is for the use case when an implementation has detected a Memory DIMM configuration error has been corrected.

May also be shown as 806f070c2003ffff or 0x806f070c2003ffff

**Severity**

Error

**Serviceable**

Yes

**Automatically notify support**

No

**Alert Category**

Critical - Memory

**SNMP Trap ID**

41

**CIM Information**

**Prefix: PLAT ID:** 0126

**User Response**

Make sure that DIMMs are installed in the correct sequence and have the same size, type, speed, and technology.

- **806f070c-2004ffff : Configuration Error for [PhysicalMemoryElementName] on Subsystem [MemoryElementName]. (DIMM 4)**

This message is for the use case when an implementation has detected a Memory DIMM configuration error has been corrected.

May also be shown as 806f070c2004ffff or 0x806f070c2004ffff

**Severity**

Error

**Serviceable**

Yes

**Automatically notify support**

No

**Alert Category**

Critical - Memory

**SNMP Trap ID**

41

**CIM Information**

**Prefix: PLAT ID:** 0126

**User Response**

Make sure that DIMMs are installed in the correct sequence and have the same size, type, speed, and technology.

- **806f070c-2005ffff : Configuration Error for [PhysicalMemoryElementName] on Subsystem [MemoryElementName]. (DIMM 5)**

This message is for the use case when an implementation has detected a Memory DIMM configuration error has been corrected.

May also be shown as 806f070c2005ffff or 0x806f070c2005ffff

**Severity**

Error

**Serviceable**

Yes

**Automatically notify support**

No

**Alert Category**

Critical - Memory

**SNMP Trap ID**

41

**CIM Information**

**Prefix: PLAT ID:** 0126

**User Response**

Make sure that DIMMs are installed in the correct sequence and have the same size, type, speed, and technology.

- **806f070c-2006ffff : Configuration Error for [PhysicalMemoryElementName] on Subsystem [MemoryElementName]. (DIMM 6)**

This message is for the use case when an implementation has detected a Memory DIMM configuration error has been corrected.

May also be shown as 806f070c2006ffff or 0x806f070c2006ffff

**Severity**

Error

**Serviceable**

Yes

**Automatically notify support**

No

**Alert Category**

Critical - Memory

**SNMP Trap ID**

41

**CIM Information**

**Prefix:** PLAT ID: 0126

**User Response**

Make sure that DIMMs are installed in the correct sequence and have the same size, type, speed, and technology.

- **806f070c-2007ffff : Configuration Error for [PhysicalMemoryElementName] on Subsystem [MemoryElementName]. (DIMM 7)**

This message is for the use case when an implementation has detected a Memory DIMM configuration error has been corrected.

May also be shown as 806f070c2007ffff or 0x806f070c2007ffff

**Severity**

Error

**Serviceable**

Yes

**Automatically notify support**

No

**Alert Category**

Critical - Memory

**SNMP Trap ID**

41

**CIM Information**

**Prefix:** PLAT ID: 0126

**User Response**

Make sure that DIMMs are installed in the correct sequence and have the same size, type, speed, and technology.

- **806f070c-2008ffff : Configuration Error for [PhysicalMemoryElementName] on Subsystem [MemoryElementName]. (DIMM 8)**

This message is for the use case when an implementation has detected a Memory DIMM configuration error has been corrected.

May also be shown as 806f070c2008ffff or 0x806f070c2008ffff

**Severity**

Error

**Serviceable**

Yes

**Automatically notify support**

No

**Alert Category**

Critical - Memory

**SNMP Trap ID**

41

**CIM Information****Prefix:** PLAT ID: 0126**User Response**

Make sure that DIMMs are installed in the correct sequence and have the same size, type, speed, and technology.

- **806f070c-2009ffff : Configuration Error for [PhysicalMemoryElementName] on Subsystem [MemoryElementName]. (DIMM 9)**

This message is for the use case when an implementation has detected a Memory DIMM configuration error has been corrected.

May also be shown as 806f070c2009ffff or 0x806f070c2009ffff

**Severity**

Error

**Serviceable**

Yes

**Automatically notify support**

No

**Alert Category**

Critical - Memory

**SNMP Trap ID**

41

**CIM Information****Prefix:** PLAT ID: 0126**User Response**

Make sure that DIMMs are installed in the correct sequence and have the same size, type, speed, and technology.

- **806f070c-200affff : Configuration Error for [PhysicalMemoryElementName] on Subsystem [MemoryElementName]. (DIMM 10)**

This message is for the use case when an implementation has detected a Memory DIMM configuration error has been corrected.

May also be shown as 806f070c200affff or 0x806f070c200affff

**Severity**

Error

**Serviceable**

Yes

**Automatically notify support**

No

**Alert Category**

Critical - Memory

**SNMP Trap ID**

41

**CIM Information****Prefix:** PLAT ID: 0126

**User Response**

Make sure that DIMMs are installed in the correct sequence and have the same size, type, speed, and technology.

- **806f070c-200bfff : Configuration Error for [PhysicalMemoryElementName] on Subsystem [MemoryElementName]. (DIMM 11)**

This message is for the use case when an implementation has detected a Memory DIMM configuration error has been corrected.

May also be shown as 806f070c200bfff or 0x806f070c200bfff

**Severity**

Error

**Serviceable**

Yes

**Automatically notify support**

No

**Alert Category**

Critical - Memory

**SNMP Trap ID**

41

**CIM Information**

**Prefix: PLAT ID:** 0126

**User Response**

Make sure that DIMMs are installed in the correct sequence and have the same size, type, speed, and technology.

- **806f070c-200cfff : Configuration Error for [PhysicalMemoryElementName] on Subsystem [MemoryElementName]. (DIMM 12)**

This message is for the use case when an implementation has detected a Memory DIMM configuration error has been corrected.

May also be shown as 806f070c200cfff or 0x806f070c200cfff

**Severity**

Error

**Serviceable**

Yes

**Automatically notify support**

No

**Alert Category**

Critical - Memory

**SNMP Trap ID**

41

**CIM Information**

**Prefix: PLAT ID:** 0126

**User Response**

Make sure that DIMMs are installed in the correct sequence and have the same size, type, speed, and technology.

- **806f070c-200dfff : Configuration Error for [PhysicalMemoryElementName] on Subsystem [MemoryElementName]. (DIMM 13)**

This message is for the use case when an implementation has detected a Memory DIMM configuration error has been corrected.

May also be shown as 806f070c200dffff or 0x806f070c200dffff

**Severity**

Error

**Serviceable**

Yes

**Automatically notify support**

No

**Alert Category**

Critical - Memory

**SNMP Trap ID**

41

**CIM Information**

Prefix: PLAT ID: 0126

**User Response**

Make sure that DIMMs are installed in the correct sequence and have the same size, type, speed, and technology.

- **806f070c-200effff : Configuration Error for [PhysicalMemoryElementName] on Subsystem [MemoryElementName]. (DIMM 14)**

This message is for the use case when an implementation has detected a Memory DIMM configuration error has been corrected.

May also be shown as 806f070c200effff or 0x806f070c200effff

**Severity**

Error

**Serviceable**

Yes

**Automatically notify support**

No

**Alert Category**

Critical - Memory

**SNMP Trap ID**

41

**CIM Information**

Prefix: PLAT ID: 0126

**User Response**

Make sure that DIMMs are installed in the correct sequence and have the same size, type, speed, and technology.

- **806f070c-200fffff : Configuration Error for [PhysicalMemoryElementName] on Subsystem [MemoryElementName]. (DIMM 15)**

This message is for the use case when an implementation has detected a Memory DIMM configuration error has been corrected.

May also be shown as 806f070c200fffff or 0x806f070c200fffff

**Severity**

Error

**Serviceable**

Yes

**Automatically notify support**

No

**Alert Category**

Critical - Memory

**SNMP Trap ID**

41

**CIM Information**

**Prefix:** PLAT ID: 0126

**User Response**

Make sure that DIMMs are installed in the correct sequence and have the same size, type, speed, and technology.

- **806f070c-2010ffff : Configuration Error for [PhysicalMemoryElementName] on Subsystem [MemoryElementName]. (DIMM 16)**

This message is for the use case when an implementation has detected a Memory DIMM configuration error has been corrected.

May also be shown as 806f070c2010ffff or 0x806f070c2010ffff

**Severity**

Error

**Serviceable**

Yes

**Automatically notify support**

No

**Alert Category**

Critical - Memory

**SNMP Trap ID**

41

**CIM Information**

**Prefix:** PLAT ID: 0126

**User Response**

Make sure that DIMMs are installed in the correct sequence and have the same size, type, speed, and technology.

- **806f070c-2011ffff : Configuration Error for [PhysicalMemoryElementName] on Subsystem [MemoryElementName]. (DIMM 17)**

This message is for the use case when an implementation has detected a Memory DIMM configuration error has been corrected.

May also be shown as 806f070c2011ffff or 0x806f070c2011ffff

**Severity**

Error

**Serviceable**

Yes

**Automatically notify support**

No

**Alert Category**

Critical - Memory

**SNMP Trap ID**

41

**CIM Information**

**Prefix: PLAT ID:** 0126

**User Response**

Make sure that DIMMs are installed in the correct sequence and have the same size, type, speed, and technology.

- **806f070c-2012ffff : Configuration Error for [PhysicalMemoryElementName] on Subsystem [MemoryElementName]. (DIMM 18)**

This message is for the use case when an implementation has detected a Memory DIMM configuration error has been corrected.

May also be shown as 806f070c2012ffff or 0x806f070c2012ffff

**Severity**

Error

**Serviceable**

Yes

**Automatically notify support**

No

**Alert Category**

Critical - Memory

**SNMP Trap ID**

41

**CIM Information**

**Prefix: PLAT ID:** 0126

**User Response**

Make sure that DIMMs are installed in the correct sequence and have the same size, type, speed, and technology.

- **806f070c-2013ffff : Configuration Error for [PhysicalMemoryElementName] on Subsystem [MemoryElementName]. (DIMM 19)**

This message is for the use case when an implementation has detected a Memory DIMM configuration error has been corrected.

May also be shown as 806f070c2013ffff or 0x806f070c2013ffff

**Severity**

Error

**Serviceable**

Yes

**Automatically notify support**

No

**Alert Category**

Critical - Memory

**SNMP Trap ID**

41

**CIM Information**



**Prefix: PLAT ID:** 0126

**User Response**

Make sure that DIMMs are installed in the correct sequence and have the same size, type, speed, and technology.

- **806f070c-2014ffff : Configuration Error for [PhysicalMemoryElementName] on Subsystem [MemoryElementName]. (DIMM 20)**

This message is for the use case when an implementation has detected a Memory DIMM configuration error has been corrected.

May also be shown as 806f070c2014ffff or 0x806f070c2014ffff

**Severity**

Error

**Serviceable**

Yes

**Automatically notify support**

No

**Alert Category**

Critical - Memory

**SNMP Trap ID**

41

**CIM Information**

**Prefix: PLAT ID:** 0126

**User Response**

Make sure that DIMMs are installed in the correct sequence and have the same size, type, speed, and technology.

- **806f070c-2015ffff : Configuration Error for [PhysicalMemoryElementName] on Subsystem [MemoryElementName]. (DIMM 21)**

This message is for the use case when an implementation has detected a Memory DIMM configuration error has been corrected.

May also be shown as 806f070c2015ffff or 0x806f070c2015ffff

**Severity**

Error

**Serviceable**

Yes

**Automatically notify support**

No

**Alert Category**

Critical - Memory

**SNMP Trap ID**

41

**CIM Information**

**Prefix: PLAT ID:** 0126

**User Response**

Make sure that DIMMs are installed in the correct sequence and have the same size, type, speed, and technology.

- **806f070c-2016ffff : Configuration Error for [PhysicalMemoryElementName] on Subsystem [MemoryElementName]. (DIMM 22)**

This message is for the use case when an implementation has detected a Memory DIMM configuration error has been corrected.

May also be shown as 806f070c2016ffff or 0x806f070c2016ffff

**Severity**

Error

**Serviceable**

Yes

**Automatically notify support**

No

**Alert Category**

Critical - Memory

**SNMP Trap ID**

41

**CIM Information**

**Prefix: PLAT ID:** 0126

**User Response**

Make sure that DIMMs are installed in the correct sequence and have the same size, type, speed, and technology.

- **806f070c-2017ffff : Configuration Error for [PhysicalMemoryElementName] on Subsystem [MemoryElementName]. (DIMM 23)**

This message is for the use case when an implementation has detected a Memory DIMM configuration error has been corrected.

May also be shown as 806f070c2017ffff or 0x806f070c2017ffff

**Severity**

Error

**Serviceable**

Yes

**Automatically notify support**

No

**Alert Category**

Critical - Memory

**SNMP Trap ID**

41

**CIM Information**

**Prefix: PLAT ID:** 0126

**User Response**

Make sure that DIMMs are installed in the correct sequence and have the same size, type, speed, and technology.

- **806f070c-2018ffff : Configuration Error for [PhysicalMemoryElementName] on Subsystem [MemoryElementName]. (DIMM 24)**

This message is for the use case when an implementation has detected a Memory DIMM configuration error has been corrected.

May also be shown as 806f070c2018ffff or 0x806f070c2018ffff

**Severity**

Error

**Serviceable**

Yes

**Automatically notify support**

No

**Alert Category**

Critical - Memory

**SNMP Trap ID**

41

**CIM Information****Prefix: PLAT ID:** 0126**User Response**

Make sure that DIMMs are installed in the correct sequence and have the same size, type, speed, and technology.

- **806f070c-2581ffff : Configuration Error for [PhysicalMemoryElementName] on Subsystem [MemoryElementName]. (All DIMMS)**

This message is for the use case when an implementation has detected a Memory DIMM configuration error has been corrected.

May also be shown as 806f070c2581ffff or 0x806f070c2581ffff

**Severity**

Error

**Serviceable**

Yes

**Automatically notify support**

No

**Alert Category**

Critical - Memory

**SNMP Trap ID**

41

**CIM Information****Prefix: PLAT ID:** 0126**User Response**

Make sure that DIMMs are installed in the correct sequence and have the same size, type, speed, and technology. One of the DIMMs :

- **806f070d-0400ffff : Rebuild in progress for Array in system [ComputerSystemElementName]. (Drive 0)**

This message is for the use case when an implementation has detected that an Array Rebuild is in Progress.

May also be shown as 806f070d0400ffff or 0x806f070d0400ffff

**Severity**

Info

**Serviceable**

No

**Automatically notify support**

No

**Alert Category**

System - Other

**SNMP Trap ID****CIM Information**

Prefix: PLAT ID: 0178

**User Response**

No action; information only.

- **806f070d-0401ffff : Rebuild in progress for Array in system [ComputerSystemElementName]. (Drive 1)**

This message is for the use case when an implementation has detected that an Array Rebuild is in Progress.

May also be shown as 806f070d0401ffff or 0x806f070d0401ffff

**Severity**

Info

**Serviceable**

No

**Automatically notify support**

No

**Alert Category**

System - Other

**SNMP Trap ID****CIM Information**

Prefix: PLAT ID: 0178

**User Response**

No action; information only.

- **806f070d-0402ffff : Rebuild in progress for Array in system [ComputerSystemElementName]. (Drive 2)**

This message is for the use case when an implementation has detected that an Array Rebuild is in Progress.

May also be shown as 806f070d0402ffff or 0x806f070d0402ffff

**Severity**

Info

**Serviceable**

No

**Automatically notify support**

No

**Alert Category**

System - Other

**SNMP Trap ID**

**CIM Information**

Prefix: PLAT ID: 0178

**User Response**

No action; information only.

- **806f070d-0403ffff : Rebuild in progress for Array in system [ComputerSystemElementName]. (Drive 3)**

This message is for the use case when an implementation has detected that an Array Rebuild is in Progress.

May also be shown as 806f070d0403ffff or 0x806f070d0403ffff

**Severity**

Info

**Serviceable**

No

**Automatically notify support**

No

**Alert Category**

System - Other

**SNMP Trap ID****CIM Information**

Prefix: PLAT ID: 0178

**User Response**

No action; information only.

- **806f070d-0404ffff : Rebuild in progress for Array in system [ComputerSystemElementName]. (Drive 4)**

This message is for the use case when an implementation has detected that an Array Rebuild is in Progress.

May also be shown as 806f070d0404ffff or 0x806f070d0404ffff

**Severity**

Info

**Serviceable**

No

**Automatically notify support**

No

**Alert Category**

System - Other

**SNMP Trap ID****CIM Information**

Prefix: PLAT ID: 0178

**User Response**

No action; information only.

- **806f070d-0405ffff : Rebuild in progress for Array in system [ComputerSystemElementName]. (Drive 5)**

This message is for the use case when an implementation has detected that an Array Rebuild is in Progress.

May also be shown as 806f070d0405ffff or 0x806f070d0405ffff

**Severity**

Info

**Serviceable**

No

**Automatically notify support**

No

**Alert Category**

System - Other

**SNMP Trap ID**

**CIM Information**

Prefix: PLAT ID: 0178

**User Response**

No action; information only.

- **806f070d-0406ffff : Rebuild in progress for Array in system [ComputerSystemElementName]. (Drive 6)**

This message is for the use case when an implementation has detected that an Array Rebuild is in Progress.

May also be shown as 806f070d0406ffff or 0x806f070d0406ffff

**Severity**

Info

**Serviceable**

No

**Automatically notify support**

No

**Alert Category**

System - Other

**SNMP Trap ID**

**CIM Information**

Prefix: PLAT ID: 0178

**User Response**

No action; information only.

- **806f070d-0407ffff : Rebuild in progress for Array in system [ComputerSystemElementName]. (Drive 7)**

This message is for the use case when an implementation has detected that an Array Rebuild is in Progress.

May also be shown as 806f070d0407ffff or 0x806f070d0407ffff

**Severity**

Info

**Serviceable**

No

**Automatically notify support**

No

**Alert Category**

System - Other

**SNMP Trap ID**

**CIM Information**

**Prefix:** PLAT ID: 0178

**User Response**

No action; information only.

- **806f070d-0408ffff : Rebuild in progress for Array in system [ComputerSystemElementName]. (Drive 8)**

This message is for the use case when an implementation has detected that an Array Rebuild is in Progress.

May also be shown as 806f070d0408ffff or 0x806f070d0408ffff

**Severity**

Info

**Serviceable**

No

**Automatically notify support**

No

**Alert Category**

System - Other

**SNMP Trap ID**

**CIM Information**

**Prefix:** PLAT ID: 0178

**User Response**

No action; information only.

- **806f070d-0409ffff : Rebuild in progress for Array in system [ComputerSystemElementName]. (Drive 9)**

This message is for the use case when an implementation has detected that an Array Rebuild is in Progress.

May also be shown as 806f070d0409ffff or 0x806f070d0409ffff

**Severity**

Info

**Serviceable**

No

**Automatically notify support**

No

**Alert Category**

System - Other

**SNMP Trap ID**

**CIM Information**

Prefix: PLAT ID: 0178

**User Response**

No action; information only.

- **806f070d-040affff : Rebuild in progress for Array in system [ComputerSystemElementName]. (Drive 10)**

This message is for the use case when an implementation has detected that an Array Rebuild is in Progress.

May also be shown as 806f070d040affff or 0x806f070d040affff

**Severity**

Info

**Serviceable**

No

**Automatically notify support**

No

**Alert Category**

System - Other

**SNMP Trap ID****CIM Information**

Prefix: PLAT ID: 0178

**User Response**

No action; information only.

- **806f070d-040bffff : Rebuild in progress for Array in system [ComputerSystemElementName]. (Drive 11)**

This message is for the use case when an implementation has detected that an Array Rebuild is in Progress.

May also be shown as 806f070d040bffff or 0x806f070d040bffff

**Severity**

Info

**Serviceable**

No

**Automatically notify support**

No

**Alert Category**

System - Other

**SNMP Trap ID****CIM Information**

Prefix: PLAT ID: 0178

**User Response**

No action; information only.



- **806f070d-040cffff : Rebuild in progress for Array in system [ComputerSystemElementName]. (Drive 12)**

This message is for the use case when an implementation has detected that an Array Rebuild is in Progress.

May also be shown as 806f070d040cffff or 0x806f070d040cffff

**Severity**

Info

**Serviceable**

No

**Automatically notify support**

No

**Alert Category**

System - Other

**SNMP Trap ID**

**CIM Information**

Prefix: PLAT ID: 0178

**User Response**

No action; information only.

- **806f070d-040dffff : Rebuild in progress for Array in system [ComputerSystemElementName]. (Drive 13)**

This message is for the use case when an implementation has detected that an Array Rebuild is in Progress.

May also be shown as 806f070d040dffff or 0x806f070d040dffff

**Severity**

Info

**Serviceable**

No

**Automatically notify support**

No

**Alert Category**

System - Other

**SNMP Trap ID**

**CIM Information**

Prefix: PLAT ID: 0178

**User Response**

No action; information only.

- **806f070d-040effff : Rebuild in progress for Array in system [ComputerSystemElementName]. (Drive 14)**

This message is for the use case when an implementation has detected that an Array Rebuild is in Progress.

May also be shown as 806f070d040effff or 0x806f070d040effff

**Severity**

Info

**Serviceable**

No

**Automatically notify support**

No

**Alert Category**

System - Other

**SNMP Trap ID**

**CIM Information**

Prefix: PLAT ID: 0178

**User Response**

No action; information only.

- **806f070d-040ffff : Rebuild in progress for Array in system [ComputerSystemElementName]. (Drive 15)**

This message is for the use case when an implementation has detected that an Array Rebuild is in Progress.

May also be shown as 806f070d040ffff or 0x806f070d040ffff

**Severity**

Info

**Serviceable**

No

**Automatically notify support**

No

**Alert Category**

System - Other

**SNMP Trap ID**

**CIM Information**

Prefix: PLAT ID: 0178

**User Response**

No action; information only.

- **806f070d-0410ffff : Rebuild in progress for Array in system [ComputerSystemElementName]. (Drive 16)**

This message is for the use case when an implementation has detected that an Array Rebuild is in Progress.

May also be shown as 806f070d0410ffff or 0x806f070d0410ffff

**Severity**

Info

**Serviceable**

No

**Automatically notify support**

No

**Alert Category**

System - Other

**SNMP Trap ID**

**CIM Information**

**Prefix:** PLAT ID: 0178

**User Response**

No action; information only.

- **806f070d-0411ffff : Rebuild in progress for Array in system [ComputerSystemElementName]. (Drive 17)**

This message is for the use case when an implementation has detected that an Array Rebuild is in Progress.

May also be shown as 806f070d0411ffff or 0x806f070d0411ffff

**Severity**

Info

**Serviceable**

No

**Automatically notify support**

No

**Alert Category**

System - Other

**SNMP Trap ID**

**CIM Information**

**Prefix:** PLAT ID: 0178

**User Response**

No action; information only.

- **806f070d-0412ffff : Rebuild in progress for Array in system [ComputerSystemElementName]. (Drive 18)**

This message is for the use case when an implementation has detected that an Array Rebuild is in Progress.

May also be shown as 806f070d0412ffff or 0x806f070d0412ffff

**Severity**

Info

**Serviceable**

No

**Automatically notify support**

No

**Alert Category**

System - Other

**SNMP Trap ID**

**CIM Information**

**Prefix:** PLAT ID: 0178

**User Response**

No action; information only.

- **806f070d-0413ffff : Rebuild in progress for Array in system [ComputerSystemElementName]. (Drive 19)**

This message is for the use case when an implementation has detected that an Array Rebuild is in Progress.

May also be shown as 806f070d0413ffff or 0x806f070d0413ffff

**Severity**

Info

**Serviceable**

No

**Automatically notify support**

No

**Alert Category**

System - Other

**SNMP Trap ID**

**CIM Information**

Prefix: PLAT ID: 0178

**User Response**

No action; information only.

- **806f070d-0414ffff : Rebuild in progress for Array in system [ComputerSystemElementName]. (Drive 20)**

This message is for the use case when an implementation has detected that an Array Rebuild is in Progress.

May also be shown as 806f070d0414ffff or 0x806f070d0414ffff

**Severity**

Info

**Serviceable**

No

**Automatically notify support**

No

**Alert Category**

System - Other

**SNMP Trap ID**

**CIM Information**

Prefix: PLAT ID: 0178

**User Response**

No action; information only.

- **806f070d-0415ffff : Rebuild in progress for Array in system [ComputerSystemElementName]. (Drive 21)**

This message is for the use case when an implementation has detected that an Array Rebuild is in Progress.

May also be shown as 806f070d0415ffff or 0x806f070d0415ffff

**Severity**

Info

**Serviceable**

No

**Automatically notify support**

No

**Alert Category**

System - Other

**SNMP Trap ID****CIM Information****Prefix: PLAT ID:** 0178**User Response**

No action; information only.

- **806f070d-0416ffff : Rebuild in progress for Array in system [ComputerSystemElementName]. (Drive 22)**

This message is for the use case when an implementation has detected that an Array Rebuild is in Progress.

May also be shown as 806f070d0416ffff or 0x806f070d0416ffff

**Severity**

Info

**Serviceable**

No

**Automatically notify support**

No

**Alert Category**

System - Other

**SNMP Trap ID****CIM Information****Prefix: PLAT ID:** 0178**User Response**

No action; information only.

- **806f070d-0417ffff : Rebuild in progress for Array in system [ComputerSystemElementName]. (Drive 23)**

This message is for the use case when an implementation has detected that an Array Rebuild is in Progress.

May also be shown as 806f070d0417ffff or 0x806f070d0417ffff

**Severity**

Info

**Serviceable**

No

**Automatically notify support**

No

**Alert Category**  
System - Other

**SNMP Trap ID**

**CIM Information**  
Prefix: PLAT ID: 0178

**User Response**  
No action; information only.

- **806f070d-0418ffff : Rebuild in progress for Array in system [ComputerSystemElementName]. (Drive 24)**

This message is for the use case when an implementation has detected that an Array Rebuild is in Progress.

May also be shown as 806f070d0418ffff or 0x806f070d0418ffff

**Severity**  
Info

**Serviceable**  
No

**Automatically notify support**  
No

**Alert Category**  
System - Other

**SNMP Trap ID**

**CIM Information**  
Prefix: PLAT ID: 0178

**User Response**  
No action; information only.

- **806f070d-0419ffff : Rebuild in progress for Array in system [ComputerSystemElementName]. (Drive 25)**

This message is for the use case when an implementation has detected that an Array Rebuild is in Progress.

May also be shown as 806f070d0419ffff or 0x806f070d0419ffff

**Severity**  
Info

**Serviceable**  
No

**Automatically notify support**  
No

**Alert Category**  
System - Other

**SNMP Trap ID**

**CIM Information**  
Prefix: PLAT ID: 0178

**User Response**

No action; information only.

- **806f070d-041affff : Rebuild in progress for Array in system [ComputerSystemElementName]. (Drive 26)**

This message is for the use case when an implementation has detected that an Array Rebuild is in Progress.

May also be shown as 806f070d041affff or 0x806f070d041affff

**Severity**

Info

**Serviceable**

No

**Automatically notify support**

No

**Alert Category**

System - Other

**SNMP Trap ID****CIM Information**

**Prefix:** PLAT ID: 0178

**User Response**

No action; information only.

- **806f070d-041bffff : Rebuild in progress for Array in system [ComputerSystemElementName]. (Drive 27)**

This message is for the use case when an implementation has detected that an Array Rebuild is in Progress.

May also be shown as 806f070d041bffff or 0x806f070d041bffff

**Severity**

Info

**Serviceable**

No

**Automatically notify support**

No

**Alert Category**

System - Other

**SNMP Trap ID****CIM Information**

**Prefix:** PLAT ID: 0178

**User Response**

No action; information only.

- **806f070d-041cffff : Rebuild in progress for Array in system [ComputerSystemElementName]. (Drive 28)**

This message is for the use case when an implementation has detected that an Array Rebuild is in Progress.

May also be shown as 806f070d041cffff or 0x806f070d041cffff

**Severity**

Info

**Serviceable**

No

**Automatically notify support**

No

**Alert Category**

System - Other

**SNMP Trap ID****CIM Information****Prefix: PLAT ID:** 0178**User Response**

No action; information only.

- **806f070d-041dffff : Rebuild in progress for Array in system [ComputerSystemElementName]. (Drive 29)**

This message is for the use case when an implementation has detected that an Array Rebuild is in Progress.

May also be shown as 806f070d041dffff or 0x806f070d041dffff

**Severity**

Info

**Serviceable**

No

**Automatically notify support**

No

**Alert Category**

System - Other

**SNMP Trap ID****CIM Information****Prefix: PLAT ID:** 0178**User Response**

No action; information only.

- **806f070d-041effff : Rebuild in progress for Array in system [ComputerSystemElementName]. (Drive 30)**

This message is for the use case when an implementation has detected that an Array Rebuild is in Progress.

May also be shown as 806f070d041effff or 0x806f070d041effff

**Severity**

Info

**Serviceable**

No

**Automatically notify support**

No



**Alert Category**

System - Other

**SNMP Trap ID****CIM Information**

Prefix: PLAT ID: 0178

**User Response**

No action; information only.

- **806f070d-041ffff : Rebuild in progress for Array in system [ComputerSystemElementName]. (Drive 31)**

This message is for the use case when an implementation has detected that an Array Rebuild is in Progress.

May also be shown as 806f070d041ffff or 0x806f070d041ffff

**Severity**

Info

**Serviceable**

No

**Automatically notify support**

No

**Alert Category**

System - Other

**SNMP Trap ID****CIM Information**

Prefix: PLAT ID: 0178

**User Response**

No action; information only.

- **806f070d-0420fff : Rebuild in progress for Array in system [ComputerSystemElementName]. (Ext Drive)**

This message is for the use case when an implementation has detected that an Array Rebuild is in Progress.

May also be shown as 806f070d0420fff or 0x806f070d0420fff

**Severity**

Info

**Serviceable**

No

**Automatically notify support**

No

**Alert Category**

System - Other

**SNMP Trap ID****CIM Information**

Prefix: PLAT ID: 0178

**User Response**

No action; information only.

- **806f072b-2101ffff : A successful software or firmware change was detected on system [ComputerSystemElementName]. (IMM Promotion)**

This message is for the use case when an implementation has detected a Successful Software or Firmware Change.

May also be shown as 806f072b2101ffff or 0x806f072b2101ffff

**Severity**

Info

**Serviceable**

No

**Automatically notify support**

No

**Alert Category**

System - Other

**SNMP Trap ID****CIM Information**

**Prefix: PLAT ID: 0450**

**User Response**

No action; information only. IMM Recovery :

- **806f072b-2201ffff : A successful software or firmware change was detected on system [ComputerSystemElementName]. (Bkup Auto Update)**

This message is for the use case when an implementation has detected a Successful Software or Firmware Change.

May also be shown as 806f072b2201ffff or 0x806f072b2201ffff

**Severity**

Info

**Serviceable**

No

**Automatically notify support**

No

**Alert Category**

System - Other

**SNMP Trap ID****CIM Information**

**Prefix: PLAT ID: 0450**

**User Response**

No action; information only. ROM Recovery :

- **806f0807-0301ffff : [ProcessorElementName] has been Disabled. (CPU 1)**

This message is for the use case when an implementation has detected a Processor has been Disabled.

May also be shown as 806f08070301ffff or 0x806f08070301ffff

**Severity**

Info

**Serviceable**

No

**Automatically notify support**

No

**Alert Category**

System - Other

**SNMP Trap ID**

**CIM Information**

**Prefix:** PLAT ID: 0061

**User Response**

No action; information only.

- **806f0807-0302ffff : [ProcessorElementName] has been Disabled. (CPU 2)**

This message is for the use case when an implementation has detected a Processor has been Disabled.

May also be shown as 806f08070302ffff or 0x806f08070302ffff

**Severity**

Info

**Serviceable**

No

**Automatically notify support**

No

**Alert Category**

System - Other

**SNMP Trap ID**

**CIM Information**

**Prefix:** PLAT ID: 0061

**User Response**

No action; information only.

- **806f0807-2584ffff : [ProcessorElementName] has been Disabled. (All CPUs)**

This message is for the use case when an implementation has detected a Processor has been Disabled.

May also be shown as 806f08072584ffff or 0x806f08072584ffff

**Severity**

Info

**Serviceable**

No

**Automatically notify support**

No

**Alert Category**

System - Other

**SNMP Trap ID**

**CIM Information**

Prefix: PLAT ID: 0061

**User Response**

No action; information only. One of the CPUs :

- **806f080c-2001ffff : Memory sparing initiated for [PhysicalMemoryElementName] on Subsystem [MemoryElementName]. (DIMM 1)**

This message is for the use case when an implementation has detected that Memory double chip sparing has been initiated.

May also be shown as 806f080c2001ffff or 0x806f080c2001ffff

**Severity**

Info

**Serviceable**

No

**Automatically notify support**

No

**Alert Category**

System - Other

**SNMP Trap ID****CIM Information**

Prefix: PLAT ID: 0140

**User Response**

No action; information only.

- **806f080c-2002ffff : Memory sparing initiated for [PhysicalMemoryElementName] on Subsystem [MemoryElementName]. (DIMM 2)**

This message is for the use case when an implementation has detected that Memory double chip sparing has been initiated.

May also be shown as 806f080c2002ffff or 0x806f080c2002ffff

**Severity**

Info

**Serviceable**

No

**Automatically notify support**

No

**Alert Category**

System - Other

**SNMP Trap ID****CIM Information**

Prefix: PLAT ID: 0140

**User Response**

No action; information only.

- **806f080c-2003ffff : Memory sparing initiated for [PhysicalMemoryElementName] on Subsystem [MemoryElementName]. (DIMM 3)**

This message is for the use case when an implementation has detected that Memory double chip sparing has been initiated.

May also be shown as 806f080c2003ffff or 0x806f080c2003ffff

**Severity**

Info

**Serviceable**

No

**Automatically notify support**

No

**Alert Category**

System - Other

**SNMP Trap ID**

**CIM Information**

Prefix: PLAT ID: 0140

**User Response**

No action; information only.

- **806f080c-2004ffff : Memory sparing initiated for [PhysicalMemoryElementName] on Subsystem [MemoryElementName]. (DIMM 4)**

This message is for the use case when an implementation has detected that Memory double chip sparing has been initiated.

May also be shown as 806f080c2004ffff or 0x806f080c2004ffff

**Severity**

Info

**Serviceable**

No

**Automatically notify support**

No

**Alert Category**

System - Other

**SNMP Trap ID**

**CIM Information**

Prefix: PLAT ID: 0140

**User Response**

No action; information only.

- **806f080c-2005ffff : Memory sparing initiated for [PhysicalMemoryElementName] on Subsystem [MemoryElementName]. (DIMM 5)**

This message is for the use case when an implementation has detected that Memory double chip sparing has been initiated.

May also be shown as 806f080c2005ffff or 0x806f080c2005ffff

**Severity**

Info

**Serviceable**

No

**Automatically notify support**

No

**Alert Category**

System - Other

**SNMP Trap ID**

**CIM Information**

Prefix: PLAT ID: 0140

**User Response**

No action; information only.

- **806f080c-2006ffff : Memory sparing initiated for [PhysicalMemoryElementName] on Subsystem [MemoryElementName]. (DIMM 6)**

This message is for the use case when an implementation has detected that Memory double chip sparing has been initiated.

May also be shown as 806f080c2006ffff or 0x806f080c2006ffff

**Severity**

Info

**Serviceable**

No

**Automatically notify support**

No

**Alert Category**

System - Other

**SNMP Trap ID**

**CIM Information**

Prefix: PLAT ID: 0140

**User Response**

No action; information only.

- **806f080c-2007ffff : Memory sparing initiated for [PhysicalMemoryElementName] on Subsystem [MemoryElementName]. (DIMM 7)**

This message is for the use case when an implementation has detected that Memory double chip sparing has been initiated.

May also be shown as 806f080c2007ffff or 0x806f080c2007ffff

**Severity**

Info

**Serviceable**

No

**Automatically notify support**

No

**Alert Category**

System - Other

**SNMP Trap ID**

**CIM Information**

Prefix: PLAT ID: 0140

**User Response**

No action; information only.

- **806f080c-2008ffff : Memory sparing initiated for [PhysicalMemoryElementName] on Subsystem [MemoryElementName]. (DIMM 8)**

This message is for the use case when an implementation has detected that Memory double chip sparing has been initiated.

May also be shown as 806f080c2008ffff or 0x806f080c2008ffff

**Severity**

Info

**Serviceable**

No

**Automatically notify support**

No

**Alert Category**

System - Other

**SNMP Trap ID****CIM Information**

Prefix: PLAT ID: 0140

**User Response**

No action; information only.

- **806f080c-2009ffff : Memory sparing initiated for [PhysicalMemoryElementName] on Subsystem [MemoryElementName]. (DIMM 9)**

This message is for the use case when an implementation has detected that Memory double chip sparing has been initiated.

May also be shown as 806f080c2009ffff or 0x806f080c2009ffff

**Severity**

Info

**Serviceable**

No

**Automatically notify support**

No

**Alert Category**

System - Other

**SNMP Trap ID****CIM Information**

Prefix: PLAT ID: 0140

**User Response**

No action; information only.

- **806f080c-200afff : Memory sparing initiated for [PhysicalMemoryElementName] on Subsystem [MemoryElementName]. (DIMM 10)**

This message is for the use case when an implementation has detected that Memory double chip sparing has been initiated.

May also be shown as 806f080c200afff or 0x806f080c200afff

**Severity**

Info

**Serviceable**

No

**Automatically notify support**

No

**Alert Category**

System - Other

**SNMP Trap ID**

**CIM Information**

Prefix: PLAT ID: 0140

**User Response**

No action; information only.

- **806f080c-200bfff : Memory sparing initiated for [PhysicalMemoryElementName] on Subsystem [MemoryElementName]. (DIMM 11)**

This message is for the use case when an implementation has detected that Memory double chip sparing has been initiated.

May also be shown as 806f080c200bfff or 0x806f080c200bfff

**Severity**

Info

**Serviceable**

No

**Automatically notify support**

No

**Alert Category**

System - Other

**SNMP Trap ID**

**CIM Information**

Prefix: PLAT ID: 0140

**User Response**

No action; information only.

- **806f080c-200cfff : Memory sparing initiated for [PhysicalMemoryElementName] on Subsystem [MemoryElementName]. (DIMM 12)**

This message is for the use case when an implementation has detected that Memory double chip sparing has been initiated.

May also be shown as 806f080c200cfff or 0x806f080c200cfff

**Severity**



Info

**Serviceable**

No

**Automatically notify support**

No

**Alert Category**

System - Other

**SNMP Trap ID**

**CIM Information**

**Prefix:** PLAT ID: 0140

**User Response**

No action; information only.

- **806f080c-200dfff : Memory sparing initiated for [PhysicalMemoryElementName] on Subsystem [MemoryElementName]. (DIMM 13)**

This message is for the use case when an implementation has detected that Memory double chip sparing has been initiated.

May also be shown as 806f080c200dfff or 0x806f080c200dfff

**Severity**

Info

**Serviceable**

No

**Automatically notify support**

No

**Alert Category**

System - Other

**SNMP Trap ID**

**CIM Information**

**Prefix:** PLAT ID: 0140

**User Response**

No action; information only.

- **806f080c-200efff : Memory sparing initiated for [PhysicalMemoryElementName] on Subsystem [MemoryElementName]. (DIMM 14)**

This message is for the use case when an implementation has detected that Memory double chip sparing has been initiated.

May also be shown as 806f080c200efff or 0x806f080c200efff

**Severity**

Info

**Serviceable**

No

**Automatically notify support**

No

**Alert Category**

System - Other

### SNMP Trap ID

#### CIM Information

Prefix: PLAT ID: 0140

#### User Response

No action; information only.

- **806f080c-200ffff** : Memory sparing initiated for [PhysicalMemoryElementName] on Subsystem [MemoryElementName]. (DIMM 15)

This message is for the use case when an implementation has detected that Memory double chip sparing has been initiated.

May also be shown as 806f080c200ffff or 0x806f080c200ffff

#### Severity

Info

#### Serviceable

No

#### Automatically notify support

No

#### Alert Category

System - Other

### SNMP Trap ID

#### CIM Information

Prefix: PLAT ID: 0140

#### User Response

No action; information only.

- **806f080c-2010fff** : Memory sparing initiated for [PhysicalMemoryElementName] on Subsystem [MemoryElementName]. (DIMM 16)

This message is for the use case when an implementation has detected that Memory double chip sparing has been initiated.

May also be shown as 806f080c2010fff or 0x806f080c2010fff

#### Severity

Info

#### Serviceable

No

#### Automatically notify support

No

#### Alert Category

System - Other

### SNMP Trap ID

#### CIM Information

Prefix: PLAT ID: 0140

#### User Response

No action; information only.

- **806f080c-2011ffff : Memory sparing initiated for [PhysicalMemoryElementName] on Subsystem [MemoryElementName]. (DIMM 17)**

This message is for the use case when an implementation has detected that Memory double chip sparing has been initiated.

May also be shown as 806f080c2011ffff or 0x806f080c2011ffff

**Severity**

Info

**Serviceable**

No

**Automatically notify support**

No

**Alert Category**

System - Other

**SNMP Trap ID**

**CIM Information**

**Prefix:** PLAT ID: 0140

**User Response**

No action; information only.

- **806f080c-2012ffff : Memory sparing initiated for [PhysicalMemoryElementName] on Subsystem [MemoryElementName]. (DIMM 18)**

This message is for the use case when an implementation has detected that Memory double chip sparing has been initiated.

May also be shown as 806f080c2012ffff or 0x806f080c2012ffff

**Severity**

Info

**Serviceable**

No

**Automatically notify support**

No

**Alert Category**

System - Other

**SNMP Trap ID**

**CIM Information**

**Prefix:** PLAT ID: 0140

**User Response**

No action; information only.

- **806f080c-2013ffff : Memory sparing initiated for [PhysicalMemoryElementName] on Subsystem [MemoryElementName]. (DIMM 19)**

This message is for the use case when an implementation has detected that Memory double chip sparing has been initiated.

May also be shown as 806f080c2013ffff or 0x806f080c2013ffff

**Severity**

Info

**Serviceable**

No

**Automatically notify support**

No

**Alert Category**

System - Other

**SNMP Trap ID****CIM Information**

Prefix: PLAT ID: 0140

**User Response**

No action; information only.

- **806f080c-2014ffff : Memory sparing initiated for [PhysicalMemoryElementName] on Subsystem [MemoryElementName]. (DIMM 20)**

This message is for the use case when an implementation has detected that Memory double chip sparing has been initiated.

May also be shown as 806f080c2014ffff or 0x806f080c2014ffff

**Severity**

Info

**Serviceable**

No

**Automatically notify support**

No

**Alert Category**

System - Other

**SNMP Trap ID****CIM Information**

Prefix: PLAT ID: 0140

**User Response**

No action; information only.

- **806f080c-2015ffff : Memory sparing initiated for [PhysicalMemoryElementName] on Subsystem [MemoryElementName]. (DIMM 21)**

This message is for the use case when an implementation has detected that Memory double chip sparing has been initiated.

May also be shown as 806f080c2015ffff or 0x806f080c2015ffff

**Severity**

Info

**Serviceable**

No

**Automatically notify support**

No

**Alert Category**

System - Other

**SNMP Trap ID****CIM Information**

Prefix: PLAT ID: 0140

**User Response**

No action; information only.

- **806f080c-2016ffff : Memory sparing initiated for [PhysicalMemoryElementName] on Subsystem [MemoryElementName]. (DIMM 22)**

This message is for the use case when an implementation has detected that Memory double chip sparing has been initiated.

May also be shown as 806f080c2016ffff or 0x806f080c2016ffff

**Severity**

Info

**Serviceable**

No

**Automatically notify support**

No

**Alert Category**

System - Other

**SNMP Trap ID****CIM Information**

Prefix: PLAT ID: 0140

**User Response**

No action; information only.

- **806f080c-2017ffff : Memory sparing initiated for [PhysicalMemoryElementName] on Subsystem [MemoryElementName]. (DIMM 23)**

This message is for the use case when an implementation has detected that Memory double chip sparing has been initiated.

May also be shown as 806f080c2017ffff or 0x806f080c2017ffff

**Severity**

Info

**Serviceable**

No

**Automatically notify support**

No

**Alert Category**

System - Other

**SNMP Trap ID****CIM Information**

Prefix: PLAT ID: 0140

**User Response**

No action; information only.

- **806f080c-2018ffff : Memory sparing initiated for [PhysicalMemoryElementName] on Subsystem [MemoryElementName]. (DIMM 24)**

This message is for the use case when an implementation has detected that Memory double chip sparing has been initiated.

May also be shown as 806f080c2018ffff or 0x806f080c2018ffff

**Severity**

Info

**Serviceable**

No

**Automatically notify support**

No

**Alert Category**

System - Other

**SNMP Trap ID****CIM Information**

Prefix: PLAT ID: 0140

**User Response**

No action; information only.

- **806f080c-2581ffff : Memory sparing initiated for [PhysicalMemoryElementName] on Subsystem [MemoryElementName]. (All DIMMS)**

This message is for the use case when an implementation has detected that Memory double chip sparing has been initiated.

May also be shown as 806f080c2581ffff or 0x806f080c2581ffff

**Severity**

Info

**Serviceable**

No

**Automatically notify support**

No

**Alert Category**

System - Other

**SNMP Trap ID****CIM Information**

Prefix: PLAT ID: 0140

**User Response**

No action; information only. One of the DIMMs :

- **806f0813-2581ffff : An Uncorrectable Bus Error has occurred on system [ComputerSystemElementName]. (DIMMs)**

This message is for the use case when an implementation has detected a Bus Uncorrectable Error.

May also be shown as 806f08132581ffff or 0x806f08132581ffff

**Severity**

Error

**Serviceable**

Yes

**Automatically notify support**

Yes

**Alert Category**

Critical - Other

**SNMP Trap ID**

50

**CIM Information****Prefix:** PLAT ID: 0240**User Response**

1. Check the system-event log.
  2. Check the DIMM error LEDs.
  3. Remove the failing DIMM from the system board.
  4. Check for a server firmware update. Important: Some cluster solutions require specific code levels or coordinated code updates. If the device is part of a cluster solution, verify that the latest level of code is supported for the cluster solution before you update the code.
  5. Make sure that the installed DIMMs are supported and configured correctly.
  6. (Trained technician only) Replace the system board.
- **806f0813-2582ffff : An Uncorrectable Bus Error has occurred on system [ComputerSystemElementName]. (PCIs)**

This message is for the use case when an implementation has detected a Bus Uncorrectable Error.

May also be shown as 806f08132582ffff or 0x806f08132582ffff

**Severity**

Error

**Serviceable**

Yes

**Automatically notify support**

Yes

**Alert Category**

Critical - Other

**SNMP Trap ID**

50

**CIM Information****Prefix:** PLAT ID: 0240**User Response**

1. Check the system-event log.
2. Check the PCI LED.
3. Remove the adapter from the indicated PCI slot.
4. Check for a server firmware update. Important: Some cluster solutions require specific code levels or coordinated code updates. If the device is part of a cluster solution, verify that the latest level of code is supported for the cluster solution before you update the code.

5. (Trained technician only) Replace the system board.
- **806f0813-2584ffff : An Uncorrectable Bus Error has occurred on system [ComputerSystemElementName]. (CPUs)**

This message is for the use case when an implementation has detected a Bus Uncorrectable Error.

May also be shown as 806f08132584ffff or 0x806f08132584ffff

**Severity**

Error

**Serviceable**

Yes

**Automatically notify support**

Yes

**Alert Category**

Critical - Other

**SNMP Trap ID**

50

**CIM Information**

**Prefix: PLAT ID:** 0240

**User Response**

1. Check the system-event log.
  2. (Trained technician only) Remove the failing microprocessor from the system board (see Removing a microprocessor and heat sink).
  3. Check for a server firmware update. Important: Some cluster solutions require specific code levels or coordinated code updates. If the device is part of a cluster solution, verify that the latest level of code is supported for the cluster solution before you update the code.
  4. Make sure that the two microprocessors are matching.
  5. (Trained technician only) Replace the system board.
- **806f0823-2101ffff : Watchdog Timer interrupt occurred for [WatchdogElementName]. (IPMI Watchdog)**

This message is for the use case when an implementation has detected a Watchdog Timer interrupt occurred.

May also be shown as 806f08232101ffff or 0x806f08232101ffff

**Severity**

Info

**Serviceable**

No

**Automatically notify support**

No

**Alert Category**

System - Other

**SNMP Trap ID**

**CIM Information**

**Prefix: PLAT ID:** 0376

**User Response**



No action; information only.

- **806f090c-2001ffff : [PhysicalMemoryElementName] on Subsystem [MemoryElementName] Throttled. (DIMM 1)**

This message is for the use case when an implementation has detected Memory has been Throttled.

May also be shown as 806f090c2001ffff or 0x806f090c2001ffff

**Severity**

Warning

**Serviceable**

Yes

**Automatically notify support**

No

**Alert Category**

System - Other

**SNMP Trap ID**

22

**CIM Information**

**Prefix: PLAT ID:** 0142

**User Response**

1. Reseat the DIMM, and then restart the server.
2. Replace DIMM n. (n = DIMM number)

- **806f090c-2002ffff : [PhysicalMemoryElementName] on Subsystem [MemoryElementName] Throttled. (DIMM 2)**

This message is for the use case when an implementation has detected Memory has been Throttled.

May also be shown as 806f090c2002ffff or 0x806f090c2002ffff

**Severity**

Warning

**Serviceable**

Yes

**Automatically notify support**

No

**Alert Category**

System - Other

**SNMP Trap ID**

22

**CIM Information**

**Prefix: PLAT ID:** 0142

**User Response**

1. Reseat the DIMM, and then restart the server.
2. Replace DIMM n. (n = DIMM number)

- **806f090c-2003ffff : [PhysicalMemoryElementName] on Subsystem [MemoryElementName] Throttled. (DIMM 3)**

This message is for the use case when an implementation has detected Memory has been Throttled.

May also be shown as 806f090c2003ffff or 0x806f090c2003ffff

**Severity**

Warning

**Serviceable**

Yes

**Automatically notify support**

No

**Alert Category**

System - Other

**SNMP Trap ID**

22

**CIM Information**

Prefix: PLAT ID: 0142

**User Response**

1. Reseat the DIMM, and then restart the server.
  2. Replace DIMM n. (n = DIMM number)
- **806f090c-2004ffff : [PhysicalMemoryElementName] on Subsystem [MemoryElementName] Throttled. (DIMM 4)**

This message is for the use case when an implementation has detected Memory has been Throttled. May also be shown as 806f090c2004ffff or 0x806f090c2004ffff

**Severity**

Warning

**Serviceable**

Yes

**Automatically notify support**

No

**Alert Category**

System - Other

**SNMP Trap ID**

22

**CIM Information**

Prefix: PLAT ID: 0142

**User Response**

1. Reseat the DIMM, and then restart the server.
  2. Replace DIMM n. (n = DIMM number)
- **806f090c-2005ffff : [PhysicalMemoryElementName] on Subsystem [MemoryElementName] Throttled. (DIMM 5)**

This message is for the use case when an implementation has detected Memory has been Throttled. May also be shown as 806f090c2005ffff or 0x806f090c2005ffff

**Severity**

Warning

**Serviceable**

Yes

**Automatically notify support**

No

**Alert Category**

System - Other

**SNMP Trap ID**

22

**CIM Information**

**Prefix: PLAT ID:** 0142

**User Response**

1. Reseat the DIMM, and then restart the server.
  2. Replace DIMM n. (n = DIMM number)
- **806f090c-2006ffff : [PhysicalMemoryElementName] on Subsystem [MemoryElementName] Throttled. (DIMM 6)**

This message is for the use case when an implementation has detected Memory has been Throttled. May also be shown as 806f090c2006ffff or 0x806f090c2006ffff

**Severity**

Warning

**Serviceable**

Yes

**Automatically notify support**

No

**Alert Category**

System - Other

**SNMP Trap ID**

22

**CIM Information**

**Prefix: PLAT ID:** 0142

**User Response**

1. Reseat the DIMM, and then restart the server.
  2. Replace DIMM n. (n = DIMM number)
- **806f090c-2007ffff : [PhysicalMemoryElementName] on Subsystem [MemoryElementName] Throttled. (DIMM 7)**

This message is for the use case when an implementation has detected Memory has been Throttled. May also be shown as 806f090c2007ffff or 0x806f090c2007ffff

**Severity**

Warning

**Serviceable**

Yes

**Automatically notify support**

No

**Alert Category**

System - Other

**SNMP Trap ID**

22

**CIM Information**

Prefix: PLAT ID: 0142

**User Response**

1. Reseat the DIMM, and then restart the server.
  2. Replace DIMM n. (n = DIMM number)
- **806f090c-2008ffff : [PhysicalMemoryElementName] on Subsystem [MemoryElementName] Throttled. (DIMM 8)**

This message is for the use case when an implementation has detected Memory has been Throttled.

May also be shown as 806f090c2008ffff or 0x806f090c2008ffff

**Severity**

Warning

**Serviceable**

Yes

**Automatically notify support**

No

**Alert Category**

System - Other

**SNMP Trap ID**

22

**CIM Information**

Prefix: PLAT ID: 0142

**User Response**

1. Reseat the DIMM, and then restart the server.
  2. Replace DIMM n. (n = DIMM number)
- **806f090c-2009ffff : [PhysicalMemoryElementName] on Subsystem [MemoryElementName] Throttled. (DIMM 9)**

This message is for the use case when an implementation has detected Memory has been Throttled.

May also be shown as 806f090c2009ffff or 0x806f090c2009ffff

**Severity**

Warning

**Serviceable**

Yes

**Automatically notify support**

No

**Alert Category**

System - Other

**SNMP Trap ID**

22

**CIM Information**

Prefix: PLAT ID: 0142

**User Response**

1. Reseat the DIMM, and then restart the server.
2. Replace DIMM n. (n = DIMM number)

- **806f090c-200affff : [PhysicalMemoryElementName] on Subsystem [MemoryElementName] Throttled. (DIMM 10)**

This message is for the use case when an implementation has detected Memory has been Throttled.  
May also be shown as 806f090c200affff or 0x806f090c200affff

**Severity**

Warning

**Serviceable**

Yes

**Automatically notify support**

No

**Alert Category**

System - Other

**SNMP Trap ID**

22

**CIM Information**

**Prefix: PLAT ID:** 0142

**User Response**

1. Reseat the DIMM, and then restart the server.
2. Replace DIMM n. (n = DIMM number)

- **806f090c-200bffff : [PhysicalMemoryElementName] on Subsystem [MemoryElementName] Throttled. (DIMM 11)**

This message is for the use case when an implementation has detected Memory has been Throttled.  
May also be shown as 806f090c200bffff or 0x806f090c200bffff

**Severity**

Warning

**Serviceable**

Yes

**Automatically notify support**

No

**Alert Category**

System - Other

**SNMP Trap ID**

22

**CIM Information**

**Prefix: PLAT ID:** 0142

**User Response**

1. Reseat the DIMM, and then restart the server.
2. Replace DIMM n. (n = DIMM number)

- **806f090c-200cffff : [PhysicalMemoryElementName] on Subsystem [MemoryElementName] Throttled. (DIMM 12)**

This message is for the use case when an implementation has detected Memory has been Throttled.  
May also be shown as 806f090c200cffff or 0x806f090c200cffff

**Severity**

Warning

**Serviceable**

Yes

**Automatically notify support**

No

**Alert Category**

System - Other

**SNMP Trap ID**

22

**CIM Information**

Prefix: PLAT ID: 0142

**User Response**

1. Reseat the DIMM, and then restart the server.
  2. Replace DIMM n. (n = DIMM number)
- **806f090c-200dffff : [PhysicalMemoryElementName] on Subsystem [MemoryElementName] Throttled. (DIMM 13)**

This message is for the use case when an implementation has detected Memory has been Throttled.

May also be shown as 806f090c200dffff or 0x806f090c200dffff

**Severity**

Warning

**Serviceable**

Yes

**Automatically notify support**

No

**Alert Category**

System - Other

**SNMP Trap ID**

22

**CIM Information**

Prefix: PLAT ID: 0142

**User Response**

1. Reseat the DIMM, and then restart the server.
  2. Replace DIMM n. (n = DIMM number)
- **806f090c-200effff : [PhysicalMemoryElementName] on Subsystem [MemoryElementName] Throttled. (DIMM 14)**

This message is for the use case when an implementation has detected Memory has been Throttled.

May also be shown as 806f090c200effff or 0x806f090c200effff

**Severity**

Warning

**Serviceable**

Yes

**Automatically notify support**

No

**Alert Category**

System - Other

**SNMP Trap ID**

22

**CIM Information**

**Prefix: PLAT ID:** 0142

**User Response**

1. Reseat the DIMM, and then restart the server.
  2. Replace DIMM n. (n = DIMM number)
- **806f090c-200ffff : [PhysicalMemoryElementName] on Subsystem [MemoryElementName] Throttled. (DIMM 15)**

This message is for the use case when an implementation has detected Memory has been Throttled.

May also be shown as 806f090c200ffff or 0x806f090c200ffff

**Severity**

Warning

**Serviceable**

Yes

**Automatically notify support**

No

**Alert Category**

System - Other

**SNMP Trap ID**

22

**CIM Information**

**Prefix: PLAT ID:** 0142

**User Response**

1. Reseat the DIMM, and then restart the server.
  2. Replace DIMM n. (n = DIMM number)
- **806f090c-2010ffff : [PhysicalMemoryElementName] on Subsystem [MemoryElementName] Throttled. (DIMM 16)**

This message is for the use case when an implementation has detected Memory has been Throttled.

May also be shown as 806f090c2010ffff or 0x806f090c2010ffff

**Severity**

Warning

**Serviceable**

Yes

**Automatically notify support**

No

**Alert Category**

System - Other

**SNMP Trap ID**

22

**CIM Information**

Prefix: PLAT ID: 0142

**User Response**

1. Reseat the DIMM, and then restart the server.
  2. Replace DIMM n. (n = DIMM number)
- **806f090c-2011ffff : [PhysicalMemoryElementName] on Subsystem [MemoryElementName] Throttled. (DIMM 17)**

This message is for the use case when an implementation has detected Memory has been Throttled.

May also be shown as 806f090c2011ffff or 0x806f090c2011ffff

**Severity**

Warning

**Serviceable**

Yes

**Automatically notify support**

No

**Alert Category**

System - Other

**SNMP Trap ID**

22

**CIM Information**

Prefix: PLAT ID: 0142

**User Response**

1. Reseat the DIMM, and then restart the server.
  2. Replace DIMM n. (n = DIMM number)
- **806f090c-2012ffff : [PhysicalMemoryElementName] on Subsystem [MemoryElementName] Throttled. (DIMM 18)**

This message is for the use case when an implementation has detected Memory has been Throttled.

May also be shown as 806f090c2012ffff or 0x806f090c2012ffff

**Severity**

Warning

**Serviceable**

Yes

**Automatically notify support**

No

**Alert Category**

System - Other

**SNMP Trap ID**

22

**CIM Information**

Prefix: PLAT ID: 0142

**User Response**

1. Reseat the DIMM, and then restart the server.
2. Replace DIMM n. (n = DIMM number)



- **806f090c-2013ffff : [PhysicalMemoryElementName] on Subsystem [MemoryElementName] Throttled. (DIMM 19)**

This message is for the use case when an implementation has detected Memory has been Throttled.  
May also be shown as 806f090c2013ffff or 0x806f090c2013ffff

**Severity**

Warning

**Serviceable**

Yes

**Automatically notify support**

No

**Alert Category**

System - Other

**SNMP Trap ID**

22

**CIM Information**

**Prefix: PLAT ID:** 0142

**User Response**

1. Reseat the DIMM, and then restart the server.
2. Replace DIMM n. (n = DIMM number)

- **806f090c-2014ffff : [PhysicalMemoryElementName] on Subsystem [MemoryElementName] Throttled. (DIMM 20)**

This message is for the use case when an implementation has detected Memory has been Throttled.  
May also be shown as 806f090c2014ffff or 0x806f090c2014ffff

**Severity**

Warning

**Serviceable**

Yes

**Automatically notify support**

No

**Alert Category**

System - Other

**SNMP Trap ID**

22

**CIM Information**

**Prefix: PLAT ID:** 0142

**User Response**

1. Reseat the DIMM, and then restart the server.
2. Replace DIMM n. (n = DIMM number)

- **806f090c-2015ffff : [PhysicalMemoryElementName] on Subsystem [MemoryElementName] Throttled. (DIMM 21)**

This message is for the use case when an implementation has detected Memory has been Throttled.  
May also be shown as 806f090c2015ffff or 0x806f090c2015ffff

**Severity**

Warning

**Serviceable**

Yes

**Automatically notify support**

No

**Alert Category**

System - Other

**SNMP Trap ID**

22

**CIM Information**

Prefix: PLAT ID: 0142

**User Response**

1. Reseat the DIMM, and then restart the server.
  2. Replace DIMM n. (n = DIMM number)
- **806f090c-2016ffff : [PhysicalMemoryElementName] on Subsystem [MemoryElementName] Throttled. (DIMM 22)**

This message is for the use case when an implementation has detected Memory has been Throttled. May also be shown as 806f090c2016ffff or 0x806f090c2016ffff

**Severity**

Warning

**Serviceable**

Yes

**Automatically notify support**

No

**Alert Category**

System - Other

**SNMP Trap ID**

22

**CIM Information**

Prefix: PLAT ID: 0142

**User Response**

1. Reseat the DIMM, and then restart the server.
  2. Replace DIMM n. (n = DIMM number)
- **806f090c-2017ffff : [PhysicalMemoryElementName] on Subsystem [MemoryElementName] Throttled. (DIMM 23)**

This message is for the use case when an implementation has detected Memory has been Throttled. May also be shown as 806f090c2017ffff or 0x806f090c2017ffff

**Severity**

Warning

**Serviceable**

Yes

**Automatically notify support**

No

**Alert Category**

System - Other

**SNMP Trap ID**

22

**CIM Information**

**Prefix:** PLAT ID: 0142

**User Response**

1. Reseat the DIMM, and then restart the server.
  2. Replace DIMM n. (n = DIMM number)
- **806f090c-2018ffff : [PhysicalMemoryElementName] on Subsystem [MemoryElementName] Throttled. (DIMM 24)**

This message is for the use case when an implementation has detected Memory has been Throttled.

May also be shown as 806f090c2018ffff or 0x806f090c2018ffff

**Severity**

Warning

**Serviceable**

Yes

**Automatically notify support**

No

**Alert Category**

System - Other

**SNMP Trap ID**

22

**CIM Information**

**Prefix:** PLAT ID: 0142

**User Response**

1. Reseat the DIMM, and then restart the server.
  2. Replace DIMM n. (n = DIMM number)
- **806f0a07-0301ffff : [ProcessorElementName] is operating in a Degraded State. (CPU 1)**

This message is for the use case when an implementation has detected a Processor is running in the Degraded state.

May also be shown as 806f0a070301ffff or 0x806f0a070301ffff

**Severity**

Warning

**Serviceable**

Yes

**Automatically notify support**

No

**Alert Category**

Warning - CPU

**SNMP Trap ID**

42

## CIM Information

Prefix: PLAT ID: 0038

## User Response

1. Make sure that the fans are operating, that there are no obstructions to the airflow (front and rear of the server), that the air baffles are in place and correctly installed, and that the server cover is installed and completely closed.
  2. Check the ambient temperature. You must be operating within the specifications.
  3. Make sure that the heat sink for microprocessor n is installed correctly.
  4. (Trained technician only) Replace microprocessor n. (n = microprocessor number)
- **806f0a07-0302ffff : [ProcessorElementName] is operating in a Degraded State. (CPU 2)**

This message is for the use case when an implementation has detected a Processor is running in the Degraded state.

May also be shown as 806f0a070302ffff or 0x806f0a070302ffff

## Severity

Warning

## Serviceable

Yes

## Automatically notify support

No

## Alert Category

Warning - CPU

## SNMP Trap ID

42

## CIM Information

Prefix: PLAT ID: 0038

## User Response

1. Make sure that the fans are operating, that there are no obstructions to the airflow (front and rear of the server), that the air baffles are in place and correctly installed, and that the server cover is installed and completely closed.
  2. Check the ambient temperature. You must be operating within the specifications.
  3. Make sure that the heat sink for microprocessor n is installed correctly.
  4. (Trained technician only) Replace microprocessor n. (n = microprocessor number)
- **806f0a0c-2001ffff : An Over-Temperature Condition has been detected on the [PhysicalMemoryElementName] on Subsystem [MemoryElementName]. (DIMM 1)**

This message is for the use case when an implementation has detected an Over Temperature Condition for Memory that has been Detected.

May also be shown as 806f0a0c2001ffff or 0x806f0a0c2001ffff

## Severity

Error

## Serviceable

Yes

## Automatically notify support

No

## Alert Category

Critical - Temperature

**SNMP Trap ID**

0

**CIM Information**

**Prefix:** PLAT ID: 0146

**User Response**

1. Make sure that the fans are operating, that there are no obstructions to the airflow, that the air baffles are in place and correctly installed, and that the server cover is installed and completely closed.
  2. Make sure that ambient temperature is within the specifications.
  3. If a fan has failed, complete the action for a fan failure.
  4. Replace DIMM n. (n = DIMM number)
- **806f0a0c-2002ffff : An Over-Temperature Condition has been detected on the [PhysicalMemoryElementName] on Subsystem [MemoryElementName]. (DIMM 2)**

This message is for the use case when an implementation has detected an Over Temperature Condition for Memory that has been Detected.

May also be shown as 806f0a0c2002ffff or 0x806f0a0c2002ffff

**Severity**

Error

**Serviceable**

Yes

**Automatically notify support**

No

**Alert Category**

Critical - Temperature

**SNMP Trap ID**

0

**CIM Information**

**Prefix:** PLAT ID: 0146

**User Response**

1. Make sure that the fans are operating, that there are no obstructions to the airflow, that the air baffles are in place and correctly installed, and that the server cover is installed and completely closed.
  2. Make sure that ambient temperature is within the specifications.
  3. If a fan has failed, complete the action for a fan failure.
  4. Replace DIMM n. (n = DIMM number)
- **806f0a0c-2003ffff : An Over-Temperature Condition has been detected on the [PhysicalMemoryElementName] on Subsystem [MemoryElementName]. (DIMM 3)**

This message is for the use case when an implementation has detected an Over Temperature Condition for Memory that has been Detected.

May also be shown as 806f0a0c2003ffff or 0x806f0a0c2003ffff

**Severity**

Error

**Serviceable**

Yes

**Automatically notify support**

No

**Alert Category**

Critical - Temperature

**SNMP Trap ID**

0

**CIM Information**

Prefix: PLAT ID: 0146

**User Response**

1. Make sure that the fans are operating, that there are no obstructions to the airflow, that the air baffles are in place and correctly installed, and that the server cover is installed and completely closed.
  2. Make sure that ambient temperature is within the specifications.
  3. If a fan has failed, complete the action for a fan failure.
  4. Replace DIMM n. (n = DIMM number)
- **806f0a0c-2004ffff : An Over-Temperature Condition has been detected on the [PhysicalMemoryElementName] on Subsystem [MemoryElementName]. (DIMM 4)**

This message is for the use case when an implementation has detected an Over Temperature Condition for Memory that has been Detected.

May also be shown as 806f0a0c2004ffff or 0x806f0a0c2004ffff

**Severity**

Error

**Serviceable**

Yes

**Automatically notify support**

No

**Alert Category**

Critical - Temperature

**SNMP Trap ID**

0

**CIM Information**

Prefix: PLAT ID: 0146

**User Response**

1. Make sure that the fans are operating, that there are no obstructions to the airflow, that the air baffles are in place and correctly installed, and that the server cover is installed and completely closed.
  2. Make sure that ambient temperature is within the specifications.
  3. If a fan has failed, complete the action for a fan failure.
  4. Replace DIMM n. (n = DIMM number)
- **806f0a0c-2005ffff : An Over-Temperature Condition has been detected on the [PhysicalMemoryElementName] on Subsystem [MemoryElementName]. (DIMM 5)**

This message is for the use case when an implementation has detected an Over Temperature Condition for Memory that has been Detected.

May also be shown as 806f0a0c2005ffff or 0x806f0a0c2005ffff

**Severity**

Error

**Serviceable**

Yes

**Automatically notify support**

No

**Alert Category**

Critical - Temperature

**SNMP Trap ID**

0

**CIM Information**

**Prefix: PLAT ID:** 0146

**User Response**

1. Make sure that the fans are operating, that there are no obstructions to the airflow, that the air baffles are in place and correctly installed, and that the server cover is installed and completely closed.
  2. Make sure that ambient temperature is within the specifications.
  3. If a fan has failed, complete the action for a fan failure.
  4. Replace DIMM n. (n = DIMM number)
- **806f0a0c-2006ffff : An Over-Temperature Condition has been detected on the [PhysicalMemoryElementName] on Subsystem [MemoryElementName]. (DIMM 6)**

This message is for the use case when an implementation has detected an Over Temperature Condition for Memory that has been Detected.

May also be shown as 806f0a0c2006ffff or 0x806f0a0c2006ffff

**Severity**

Error

**Serviceable**

Yes

**Automatically notify support**

No

**Alert Category**

Critical - Temperature

**SNMP Trap ID**

0

**CIM Information**

**Prefix: PLAT ID:** 0146

**User Response**

1. Make sure that the fans are operating, that there are no obstructions to the airflow, that the air baffles are in place and correctly installed, and that the server cover is installed and completely closed.
2. Make sure that ambient temperature is within the specifications.
3. If a fan has failed, complete the action for a fan failure.

4. Replace DIMM n. (n = DIMM number)

- **806f0a0c-2007ffff : An Over-Temperature Condition has been detected on the [PhysicalMemoryElementName] on Subsystem [MemoryElementName]. (DIMM 7)**

This message is for the use case when an implementation has detected an Over Temperature Condition for Memory that has been Detected.

May also be shown as 806f0a0c2007ffff or 0x806f0a0c2007ffff

**Severity**

Error

**Serviceable**

Yes

**Automatically notify support**

No

**Alert Category**

Critical - Temperature

**SNMP Trap ID**

0

**CIM Information**

**Prefix: PLAT ID:** 0146

**User Response**

1. Make sure that the fans are operating, that there are no obstructions to the airflow, that the air baffles are in place and correctly installed, and that the server cover is installed and completely closed.
2. Make sure that ambient temperature is within the specifications.
3. If a fan has failed, complete the action for a fan failure.
4. Replace DIMM n. (n = DIMM number)

- **806f0a0c-2008ffff : An Over-Temperature Condition has been detected on the [PhysicalMemoryElementName] on Subsystem [MemoryElementName]. (DIMM 8)**

This message is for the use case when an implementation has detected an Over Temperature Condition for Memory that has been Detected.

May also be shown as 806f0a0c2008ffff or 0x806f0a0c2008ffff

**Severity**

Error

**Serviceable**

Yes

**Automatically notify support**

No

**Alert Category**

Critical - Temperature

**SNMP Trap ID**

0

**CIM Information**

**Prefix: PLAT ID:** 0146

**User Response**



1. Make sure that the fans are operating, that there are no obstructions to the airflow, that the air baffles are in place and correctly installed, and that the server cover is installed and completely closed.
2. Make sure that ambient temperature is within the specifications.
3. If a fan has failed, complete the action for a fan failure.
4. Replace DIMM n. (n = DIMM number)

- **806f0a0c-2009ffff : An Over-Temperature Condition has been detected on the [PhysicalMemoryElementName] on Subsystem [MemoryElementName]. (DIMM 9)**

This message is for the use case when an implementation has detected an Over Temperature Condition for Memory that has been Detected.

May also be shown as 806f0a0c2009ffff or 0x806f0a0c2009ffff

**Severity**

Error

**Serviceable**

Yes

**Automatically notify support**

No

**Alert Category**

Critical - Temperature

**SNMP Trap ID**

0

**CIM Information**

**Prefix:** PLAT ID: 0146

**User Response**

1. Make sure that the fans are operating, that there are no obstructions to the airflow, that the air baffles are in place and correctly installed, and that the server cover is installed and completely closed.
2. Make sure that ambient temperature is within the specifications.
3. If a fan has failed, complete the action for a fan failure.
4. Replace DIMM n. (n = DIMM number)

- **806f0a0c-200affff : An Over-Temperature Condition has been detected on the [PhysicalMemoryElementName] on Subsystem [MemoryElementName]. (DIMM 10)**

This message is for the use case when an implementation has detected an Over Temperature Condition for Memory that has been Detected.

May also be shown as 806f0a0c200affff or 0x806f0a0c200affff

**Severity**

Error

**Serviceable**

Yes

**Automatically notify support**

No

**Alert Category**

Critical - Temperature

**SNMP Trap ID**

0

### CIM Information

Prefix: PLAT ID: 0146

### User Response

1. Make sure that the fans are operating, that there are no obstructions to the airflow, that the air baffles are in place and correctly installed, and that the server cover is installed and completely closed.
  2. Make sure that ambient temperature is within the specifications.
  3. If a fan has failed, complete the action for a fan failure.
  4. Replace DIMM n. (n = DIMM number)
- **806f0a0c-200bffff : An Over-Temperature Condition has been detected on the [PhysicalMemoryElementName] on Subsystem [MemoryElementName]. (DIMM 11)**

This message is for the use case when an implementation has detected an Over Temperature Condition for Memory that has been Detected.

May also be shown as 806f0a0c200bffff or 0x806f0a0c200bffff

### Severity

Error

### Serviceable

Yes

### Automatically notify support

No

### Alert Category

Critical - Temperature

### SNMP Trap ID

0

### CIM Information

Prefix: PLAT ID: 0146

### User Response

1. Make sure that the fans are operating, that there are no obstructions to the airflow, that the air baffles are in place and correctly installed, and that the server cover is installed and completely closed.
  2. Make sure that ambient temperature is within the specifications.
  3. If a fan has failed, complete the action for a fan failure.
  4. Replace DIMM n. (n = DIMM number)
- **806f0a0c-200cffff : An Over-Temperature Condition has been detected on the [PhysicalMemoryElementName] on Subsystem [MemoryElementName]. (DIMM 12)**

This message is for the use case when an implementation has detected an Over Temperature Condition for Memory that has been Detected.

May also be shown as 806f0a0c200cffff or 0x806f0a0c200cffff

### Severity

Error

### Serviceable

Yes

### Automatically notify support

No

**Alert Category**

Critical - Temperature

**SNMP Trap ID**

0

**CIM Information**

**Prefix: PLAT ID:** 0146

**User Response**

1. Make sure that the fans are operating, that there are no obstructions to the airflow, that the air baffles are in place and correctly installed, and that the server cover is installed and completely closed.
  2. Make sure that ambient temperature is within the specifications.
  3. If a fan has failed, complete the action for a fan failure.
  4. Replace DIMM n. (n = DIMM number)
- **806f0a0c-200dffff : An Over-Temperature Condition has been detected on the [PhysicalMemoryElementName] on Subsystem [MemoryElementName]. (DIMM 13)**

This message is for the use case when an implementation has detected an Over Temperature Condition for Memory that has been Detected.

May also be shown as 806f0a0c200dffff or 0x806f0a0c200dffff

**Severity**

Error

**Serviceable**

Yes

**Automatically notify support**

No

**Alert Category**

Critical - Temperature

**SNMP Trap ID**

0

**CIM Information**

**Prefix: PLAT ID:** 0146

**User Response**

1. Make sure that the fans are operating, that there are no obstructions to the airflow, that the air baffles are in place and correctly installed, and that the server cover is installed and completely closed.
  2. Make sure that ambient temperature is within the specifications.
  3. If a fan has failed, complete the action for a fan failure.
  4. Replace DIMM n. (n = DIMM number)
- **806f0a0c-200effff : An Over-Temperature Condition has been detected on the [PhysicalMemoryElementName] on Subsystem [MemoryElementName]. (DIMM 14)**

This message is for the use case when an implementation has detected an Over Temperature Condition for Memory that has been Detected.

May also be shown as 806f0a0c200effff or 0x806f0a0c200effff

**Severity**

Error

**Serviceable**

Yes

**Automatically notify support**

No

**Alert Category**

Critical - Temperature

**SNMP Trap ID**

0

**CIM Information**

**Prefix: PLAT ID:** 0146

**User Response**

1. Make sure that the fans are operating, that there are no obstructions to the airflow, that the air baffles are in place and correctly installed, and that the server cover is installed and completely closed.
  2. Make sure that ambient temperature is within the specifications.
  3. If a fan has failed, complete the action for a fan failure.
  4. Replace DIMM n. (n = DIMM number)
- **806f0a0c-200ffff : An Over-Temperature Condition has been detected on the [PhysicalMemoryElementName] on Subsystem [MemoryElementName]. (DIMM 15)**

This message is for the use case when an implementation has detected an Over Temperature Condition for Memory that has been Detected.

May also be shown as 806f0a0c200ffff or 0x806f0a0c200ffff

**Severity**

Error

**Serviceable**

Yes

**Automatically notify support**

No

**Alert Category**

Critical - Temperature

**SNMP Trap ID**

0

**CIM Information**

**Prefix: PLAT ID:** 0146

**User Response**

1. Make sure that the fans are operating, that there are no obstructions to the airflow, that the air baffles are in place and correctly installed, and that the server cover is installed and completely closed.
  2. Make sure that ambient temperature is within the specifications.
  3. If a fan has failed, complete the action for a fan failure.
  4. Replace DIMM n. (n = DIMM number)
- **806f0a0c-2010fff : An Over-Temperature Condition has been detected on the [PhysicalMemoryElementName] on Subsystem [MemoryElementName]. (DIMM 16)**

This message is for the use case when an implementation has detected an Over Temperature Condition for Memory that has been Detected.

May also be shown as 806f0a0c2010ffff or 0x806f0a0c2010ffff

**Severity**

Error

**Serviceable**

Yes

**Automatically notify support**

No

**Alert Category**

Critical - Temperature

**SNMP Trap ID**

0

**CIM Information**

Prefix: PLAT ID: 0146

**User Response**

1. Make sure that the fans are operating, that there are no obstructions to the airflow, that the air baffles are in place and correctly installed, and that the server cover is installed and completely closed.
  2. Make sure that ambient temperature is within the specifications.
  3. If a fan has failed, complete the action for a fan failure.
  4. Replace DIMM n. (n = DIMM number)
- **806f0a0c-2011ffff : An Over-Temperature Condition has been detected on the [PhysicalMemoryElementName] on Subsystem [MemoryElementName]. (DIMM 17)**

This message is for the use case when an implementation has detected an Over Temperature Condition for Memory that has been Detected.

May also be shown as 806f0a0c2011ffff or 0x806f0a0c2011ffff

**Severity**

Error

**Serviceable**

Yes

**Automatically notify support**

No

**Alert Category**

Critical - Temperature

**SNMP Trap ID**

0

**CIM Information**

Prefix: PLAT ID: 0146

**User Response**

1. Make sure that the fans are operating, that there are no obstructions to the airflow, that the air baffles are in place and correctly installed, and that the server cover is installed and completely closed.
2. Make sure that ambient temperature is within the specifications.

3. If a fan has failed, complete the action for a fan failure.
  4. Replace DIMM n. (n = DIMM number)
- **806f0a0c-2012ffff : An Over-Temperature Condition has been detected on the [PhysicalMemoryElementName] on Subsystem [MemoryElementName]. (DIMM 18)**

This message is for the use case when an implementation has detected an Over Temperature Condition for Memory that has been Detected.

May also be shown as 806f0a0c2012ffff or 0x806f0a0c2012ffff

**Severity**

Error

**Serviceable**

Yes

**Automatically notify support**

No

**Alert Category**

Critical - Temperature

**SNMP Trap ID**

0

**CIM Information**

**Prefix: PLAT ID:** 0146

**User Response**

1. Make sure that the fans are operating, that there are no obstructions to the airflow, that the air baffles are in place and correctly installed, and that the server cover is installed and completely closed.
  2. Make sure that ambient temperature is within the specifications.
  3. If a fan has failed, complete the action for a fan failure.
  4. Replace DIMM n. (n = DIMM number)
- **806f0a0c-2013ffff : An Over-Temperature Condition has been detected on the [PhysicalMemoryElementName] on Subsystem [MemoryElementName]. (DIMM 19)**

This message is for the use case when an implementation has detected an Over Temperature Condition for Memory that has been Detected.

May also be shown as 806f0a0c2013ffff or 0x806f0a0c2013ffff

**Severity**

Error

**Serviceable**

Yes

**Automatically notify support**

No

**Alert Category**

Critical - Temperature

**SNMP Trap ID**

0

**CIM Information**

**Prefix: PLAT ID:** 0146

**User Response**

1. Make sure that the fans are operating, that there are no obstructions to the airflow, that the air baffles are in place and correctly installed, and that the server cover is installed and completely closed.
2. Make sure that ambient temperature is within the specifications.
3. If a fan has failed, complete the action for a fan failure.
4. Replace DIMM n. (n = DIMM number)

- **806f0a0c-2014ffff : An Over-Temperature Condition has been detected on the [PhysicalMemoryElementName] on Subsystem [MemoryElementName]. (DIMM 20)**

This message is for the use case when an implementation has detected an Over Temperature Condition for Memory that has been Detected.

May also be shown as 806f0a0c2014ffff or 0x806f0a0c2014ffff

**Severity**

Error

**Serviceable**

Yes

**Automatically notify support**

No

**Alert Category**

Critical - Temperature

**SNMP Trap ID**

0

**CIM Information**

**Prefix:** PLAT ID: 0146

**User Response**

1. Make sure that the fans are operating, that there are no obstructions to the airflow, that the air baffles are in place and correctly installed, and that the server cover is installed and completely closed.
2. Make sure that ambient temperature is within the specifications.
3. If a fan has failed, complete the action for a fan failure.
4. Replace DIMM n. (n = DIMM number)

- **806f0a0c-2015ffff : An Over-Temperature Condition has been detected on the [PhysicalMemoryElementName] on Subsystem [MemoryElementName]. (DIMM 21)**

This message is for the use case when an implementation has detected an Over Temperature Condition for Memory that has been Detected.

May also be shown as 806f0a0c2015ffff or 0x806f0a0c2015ffff

**Severity**

Error

**Serviceable**

Yes

**Automatically notify support**

No

**Alert Category**

Critical - Temperature

**SNMP Trap ID**

0

#### **CIM Information**

**Prefix:** PLAT ID: 0146

#### **User Response**

1. Make sure that the fans are operating, that there are no obstructions to the airflow, that the air baffles are in place and correctly installed, and that the server cover is installed and completely closed.
  2. Make sure that ambient temperature is within the specifications.
  3. If a fan has failed, complete the action for a fan failure.
  4. Replace DIMM n. (n = DIMM number)
- **806f0a0c-2016ffff : An Over-Temperature Condition has been detected on the [PhysicalMemoryElementName] on Subsystem [MemoryElementName]. (DIMM 22)**

This message is for the use case when an implementation has detected an Over Temperature Condition for Memory that has been Detected.

May also be shown as 806f0a0c2016ffff or 0x806f0a0c2016ffff

#### **Severity**

Error

#### **Serviceable**

Yes

#### **Automatically notify support**

No

#### **Alert Category**

Critical - Temperature

#### **SNMP Trap ID**

0

#### **CIM Information**

**Prefix:** PLAT ID: 0146

#### **User Response**

1. Make sure that the fans are operating, that there are no obstructions to the airflow, that the air baffles are in place and correctly installed, and that the server cover is installed and completely closed.
  2. Make sure that ambient temperature is within the specifications.
  3. If a fan has failed, complete the action for a fan failure.
  4. Replace DIMM n. (n = DIMM number)
- **806f0a0c-2017ffff : An Over-Temperature Condition has been detected on the [PhysicalMemoryElementName] on Subsystem [MemoryElementName]. (DIMM 23)**

This message is for the use case when an implementation has detected an Over Temperature Condition for Memory that has been Detected.

May also be shown as 806f0a0c2017ffff or 0x806f0a0c2017ffff

#### **Severity**

Error

#### **Serviceable**

Yes

#### **Automatically notify support**



No

**Alert Category**

Critical - Temperature

**SNMP Trap ID**

0

**CIM Information**

**Prefix:** PLAT ID: 0146

**User Response**

1. Make sure that the fans are operating, that there are no obstructions to the airflow, that the air baffles are in place and correctly installed, and that the server cover is installed and completely closed.
  2. Make sure that ambient temperature is within the specifications.
  3. If a fan has failed, complete the action for a fan failure.
  4. Replace DIMM n. (n = DIMM number)
- **806f0a0c-2018ffff : An Over-Temperature Condition has been detected on the [PhysicalMemoryElementName] on Subsystem [MemoryElementName]. (DIMM 24)**

This message is for the use case when an implementation has detected an Over Temperature Condition for Memory that has been Detected.

May also be shown as 806f0a0c2018ffff or 0x806f0a0c2018ffff

**Severity**

Error

**Serviceable**

Yes

**Automatically notify support**

No

**Alert Category**

Critical - Temperature

**SNMP Trap ID**

0

**CIM Information**

**Prefix:** PLAT ID: 0146

**User Response**

1. Make sure that the fans are operating, that there are no obstructions to the airflow, that the air baffles are in place and correctly installed, and that the server cover is installed and completely closed.
  2. Make sure that ambient temperature is within the specifications.
  3. If a fan has failed, complete the action for a fan failure.
  4. Replace DIMM n. (n = DIMM number)
- **806f0a13-0301ffff : A Fatal Bus Error has occurred on system [ComputerSystemElementName]. (CPU 1 PECl)**

This message is for the use case when an implementation has detected a Bus Fatal Error.

May also be shown as 806f0a130301ffff or 0x806f0a130301ffff

**Severity**

Error

**Serviceable**

Yes

**Automatically notify support**

No

**Alert Category**

Critical - Other

**SNMP Trap ID**

50

**CIM Information**

Prefix: PLAT ID: 0244

**User Response**

1. Reseat the microprocessor, and then restart the server.
  2. Replace microprocessor n. (n = microprocessor number)
- **806f0a13-0302ffff : A Fatal Bus Error has occurred on system [ComputerSystemElementName]. (CPU 2 PECl)**

This message is for the use case when an implementation has detected a Bus Fatal Error.

May also be shown as 806f0a130302ffff or 0x806f0a130302ffff

**Severity**

Error

**Serviceable**

Yes

**Automatically notify support**

No

**Alert Category**

Critical - Other

**SNMP Trap ID**

50

**CIM Information**

Prefix: PLAT ID: 0244

**User Response**

1. Reseat the microprocessor, and then restart the server.
  2. Replace microprocessor n. (n = microprocessor number)
- **81010002-0701ffff : Numeric sensor [NumericSensorElementName] going low (lower non-critical) has deasserted. (CMOS Battery)**

This message is for the use case when an implementation has detected a Lower Non-critical sensor going low has deasserted.

May also be shown as 810100020701ffff or 0x810100020701ffff

**Severity**

Info

**Serviceable**

No

**Automatically notify support**

No

**Alert Category**

Warning - Voltage

**SNMP Trap ID**

13

**CIM Information**

**Prefix:** PLAT ID: 0477

**User Response**

No action; information only.

- **81010202-0701ffff : Numeric sensor [NumericSensorElementName] going low (lower critical) has deasserted. (CMOS Battery)**

This message is for the use case when an implementation has detected a Lower Critical sensor going low has deasserted.

May also be shown as 810102020701ffff or 0x810102020701ffff

**Severity**

Info

**Serviceable**

No

**Automatically notify support**

No

**Alert Category**

Critical - Voltage

**SNMP Trap ID**

1

**CIM Information**

**Prefix:** PLAT ID: 0481

**User Response**

No action; information only. SysBrd 12V : SysBrd 3.3V : SysBrd 5V :

- **81010204-1d01ffff : Numeric sensor [NumericSensorElementName] going low (lower critical) has deasserted. (Fan 1A Tach)**

This message is for the use case when an implementation has detected a Lower Critical sensor going low has deasserted.

May also be shown as 810102041d01ffff or 0x810102041d01ffff

**Severity**

Info

**Serviceable**

No

**Automatically notify support**

No

**Alert Category**

Critical - Fan Failure

**SNMP Trap ID**

11

**CIM Information**

**Prefix:** PLAT ID: 0481

### User Response

No action; information only. Fan 1B Tach :

- **81010204-1d02ffff : Numeric sensor [NumericSensorElementName] going low (lower critical) has deasserted. (Fan 2A Tach)**

This message is for the use case when an implementation has detected a Lower Critical sensor going low has deasserted.

May also be shown as 810102041d02ffff or 0x810102041d02ffff

### Severity

Info

### Serviceable

No

### Automatically notify support

No

### Alert Category

Critical - Fan Failure

### SNMP Trap ID

11

### CIM Information

Prefix: PLAT ID: 0481

### User Response

No action; information only. Fan 2B Tach :

- **81010204-1d03ffff : Numeric sensor [NumericSensorElementName] going low (lower critical) has deasserted. (Fan 3A Tach)**

This message is for the use case when an implementation has detected a Lower Critical sensor going low has deasserted.

May also be shown as 810102041d03ffff or 0x810102041d03ffff

### Severity

Info

### Serviceable

No

### Automatically notify support

No

### Alert Category

Critical - Fan Failure

### SNMP Trap ID

11

### CIM Information

Prefix: PLAT ID: 0481

### User Response

No action; information only. Fan 3B Tach :

- **81010204-1d04ffff : Numeric sensor [NumericSensorElementName] going low (lower critical) has deasserted. (Fan 4A Tach)**

This message is for the use case when an implementation has detected a Lower Critical sensor going low has deasserted.

May also be shown as 810102041d04ffff or 0x810102041d04ffff

**Severity**

Info

**Serviceable**

No

**Automatically notify support**

No

**Alert Category**

Critical - Fan Failure

**SNMP Trap ID**

11

**CIM Information****Prefix:** PLAT ID: 0481**User Response**

No action; information only. Fan 4B Tach :

- **81010204-1d05ffff : Numeric sensor [NumericSensorElementName] going low (lower critical) has deasserted. (Fan 5A Tach)**

This message is for the use case when an implementation has detected a Lower Critical sensor going low has deasserted.

May also be shown as 810102041d05ffff or 0x810102041d05ffff

**Severity**

Info

**Serviceable**

No

**Automatically notify support**

No

**Alert Category**

Critical - Fan Failure

**SNMP Trap ID**

11

**CIM Information****Prefix:** PLAT ID: 0481**User Response**

No action; information only. Fan 5B Tach :

- **81010204-1d06ffff : Numeric sensor [NumericSensorElementName] going low (lower critical) has deasserted. (Fan 6A Tach)**

This message is for the use case when an implementation has detected a Lower Critical sensor going low has deasserted.

May also be shown as 810102041d06ffff or 0x810102041d06ffff

**Severity**

Info

**Serviceable**

No

**Automatically notify support**

No

**Alert Category**

Critical - Fan Failure

**SNMP Trap ID**

11

**CIM Information**

Prefix: PLAT ID: 0481

**User Response**

No action; information only. Fan 6B Tach :

- **81010204-1d07ffff : Numeric sensor [NumericSensorElementName] going low (lower critical) has deasserted. (Fan Riser1A Tach)**

This message is for the use case when an implementation has detected a Lower Critical sensor going low has deasserted.

May also be shown as 810102041d07ffff or 0x810102041d07ffff

**Severity**

Info

**Serviceable**

No

**Automatically notify support**

No

**Alert Category**

Critical - Fan Failure

**SNMP Trap ID**

11

**CIM Information**

Prefix: PLAT ID: 0481

**User Response**

No action; information only.

- **81010204-1d08ffff : Numeric sensor [NumericSensorElementName] going low (lower critical) has deasserted. (Fan Riser1B Tach)**

This message is for the use case when an implementation has detected a Lower Critical sensor going low has deasserted.

May also be shown as 810102041d08ffff or 0x810102041d08ffff

**Severity**

Info

**Serviceable**

No

**Automatically notify support**

No

**Alert Category**

Critical - Fan Failure

**SNMP Trap ID**

11

**CIM Information**

Prefix: PLAT ID: 0481

**User Response**

No action; information only.

- **81010204-1d09ffff : Numeric sensor [NumericSensorElementName] going low (lower critical) has deasserted. (Fan Riser2A Tach)**

This message is for the use case when an implementation has detected a Lower Critical sensor going low has deasserted.

May also be shown as 810102041d09ffff or 0x810102041d09ffff

**Severity**

Info

**Serviceable**

No

**Automatically notify support**

No

**Alert Category**

Critical - Fan Failure

**SNMP Trap ID**

11

**CIM Information**

**Prefix:** PLAT ID: 0481

**User Response**

No action; information only.

- **81010204-1d0affff : Numeric sensor [NumericSensorElementName] going low (lower critical) has deasserted. (Fan Riser2B Tach)**

This message is for the use case when an implementation has detected a Lower Critical sensor going low has deasserted.

May also be shown as 810102041d0affff or 0x810102041d0affff

**Severity**

Info

**Serviceable**

No

**Automatically notify support**

No

**Alert Category**

Critical - Fan Failure

**SNMP Trap ID**

11

**CIM Information**

**Prefix:** PLAT ID: 0481

**User Response**

No action; information only.

- **81010701-0701ffff : Numeric sensor [NumericSensorElementName] going high (upper non-critical) has deasserted. (RS1 RR Amb Temp)**

This message is for the use case when an implementation has detected an Upper Non-critical sensor going high has deasserted.

May also be shown as 810107010701ffff or 0x810107010701ffff

**Severity**

Info

**Serviceable**

No

**Automatically notify support**

No

**Alert Category**

Warning - Temperature

**SNMP Trap ID**

12

**CIM Information****Prefix: PLAT ID:** 0491**User Response**

No action; information only.

- **81010701-0702ffff : Numeric sensor [NumericSensorElementName] going high (upper non-critical) has deasserted. (RS2 RR Amb Temp)**

This message is for the use case when an implementation has detected an Upper Non-critical sensor going high has deasserted.

May also be shown as 810107010702ffff or 0x810107010702ffff

**Severity**

Info

**Serviceable**

No

**Automatically notify support**

No

**Alert Category**

Warning - Temperature

**SNMP Trap ID**

12

**CIM Information****Prefix: PLAT ID:** 0491**User Response**

No action; information only.

- **81010701-0703ffff : Numeric sensor [NumericSensorElementName] going high (upper non-critical) has deasserted. (MID1 RR Amb Temp)**

This message is for the use case when an implementation has detected an Upper Non-critical sensor going high has deasserted.

May also be shown as 810107010703ffff or 0x810107010703ffff

**Severity**

Info

**Serviceable**

No

**Automatically notify support**

No



**Alert Category**

Warning - Temperature

**SNMP Trap ID**

12

**CIM Information**

**Prefix:** PLAT ID: 0491

**User Response**

No action; information only.

- **81010701-0704ffff : Numeric sensor [NumericSensorElementName] going high (upper non-critical) has deasserted. (MID2 RR Amb Temp)**

This message is for the use case when an implementation has detected an Upper Non-critical sensor going high has deasserted.

May also be shown as 810107010704ffff or 0x810107010704ffff

**Severity**

Info

**Serviceable**

No

**Automatically notify support**

No

**Alert Category**

Warning - Temperature

**SNMP Trap ID**

12

**CIM Information**

**Prefix:** PLAT ID: 0491

**User Response**

No action; information only.

- **81010701-0705ffff : Numeric sensor [NumericSensorElementName] going high (upper non-critical) has deasserted. (RAID RR Amb Temp)**

This message is for the use case when an implementation has detected an Upper Non-critical sensor going high has deasserted.

May also be shown as 810107010705ffff or 0x810107010705ffff

**Severity**

Info

**Serviceable**

No

**Automatically notify support**

No

**Alert Category**

Warning - Temperature

**SNMP Trap ID**

12

**CIM Information**

**Prefix:** PLAT ID: 0491

**User Response**

No action; information only.

- **81010701-0706ffff : Numeric sensor [NumericSensorElementName] going high (upper non-critical) has deasserted. (PSU FR Amb Temp)**

This message is for the use case when an implementation has detected an Upper Non-critical sensor going high has deasserted.

May also be shown as 810107010706ffff or 0x810107010706ffff

**Severity**

Info

**Serviceable**

No

**Automatically notify support**

No

**Alert Category**

Warning - Temperature

**SNMP Trap ID**

12

**CIM Information**

Prefix: PLAT ID: 0491

**User Response**

No action; information only.

- **81010701-0707ffff : Numeric sensor [NumericSensorElementName] going high (upper non-critical) has deasserted. (Rear BP1 Temp)**

This message is for the use case when an implementation has detected an Upper Non-critical sensor going high has deasserted.

May also be shown as 810107010707ffff or 0x810107010707ffff

**Severity**

Info

**Serviceable**

No

**Automatically notify support**

No

**Alert Category**

Warning - Temperature

**SNMP Trap ID**

12

**CIM Information**

Prefix: PLAT ID: 0491

**User Response**

No action; information only.

- **81010701-0708ffff : Numeric sensor [NumericSensorElementName] going high (upper non-critical) has deasserted. (Rear BP2 Temp)**

This message is for the use case when an implementation has detected an Upper Non-critical sensor going high has deasserted.

May also be shown as 810107010708ffff or 0x810107010708ffff

**Severity**

Info

**Serviceable**

No

**Automatically notify support**

No

**Alert Category**

Warning - Temperature

**SNMP Trap ID**

12

**CIM Information****Prefix: PLAT ID:** 0491**User Response**

No action; information only.

- **81010701-1401ffff : Numeric sensor [NumericSensorElementName] going high (upper non-critical) has deasserted. (CPU1 VR Temp)**

This message is for the use case when an implementation has detected an Upper Non-critical sensor going high has deasserted.

May also be shown as 810107011401ffff or 0x810107011401ffff

**Severity**

Info

**Serviceable**

No

**Automatically notify support**

No

**Alert Category**

Warning - Temperature

**SNMP Trap ID**

12

**CIM Information****Prefix: PLAT ID:** 0491**User Response**

No action; information only.

- **81010701-1402ffff : Numeric sensor [NumericSensorElementName] going high (upper non-critical) has deasserted. (CPU2 VR Temp)**

This message is for the use case when an implementation has detected an Upper Non-critical sensor going high has deasserted.

May also be shown as 810107011402ffff or 0x810107011402ffff

**Severity**

Info

**Serviceable**

No

**Automatically notify support**

No

**Alert Category**

Warning - Temperature

**SNMP Trap ID**

12

**CIM Information**

Prefix: PLAT ID: 0491

**User Response**

No action; information only.

- **81010701-1403ffff : Numeric sensor [NumericSensorElementName] going high (upper non-critical) has deasserted. (DIMM AB VR Temp)**

This message is for the use case when an implementation has detected an Upper Non-critical sensor going high has deasserted.

May also be shown as 810107011403ffff or 0x810107011403ffff

**Severity**

Info

**Serviceable**

No

**Automatically notify support**

No

**Alert Category**

Warning - Temperature

**SNMP Trap ID**

12

**CIM Information**

Prefix: PLAT ID: 0491

**User Response**

No action; information only.

- **81010701-1404ffff : Numeric sensor [NumericSensorElementName] going high (upper non-critical) has deasserted. (DIMM CD VR Temp)**

This message is for the use case when an implementation has detected an Upper Non-critical sensor going high has deasserted.

May also be shown as 810107011404ffff or 0x810107011404ffff

**Severity**

Info

**Serviceable**

No

**Automatically notify support**

No

**Alert Category**

Warning - Temperature

**SNMP Trap ID**

12

**CIM Information**

Prefix: PLAT ID: 0491

**User Response**

No action; information only.

- **81010701-1405ffff : Numeric sensor [NumericSensorElementName] going high (upper non-critical) has deasserted. (DIMM EF VR Temp)**

This message is for the use case when an implementation has detected an Upper Non-critical sensor going high has deasserted.

May also be shown as 810107011405ffff or 0x810107011405ffff

**Severity**

Info

**Serviceable**

No

**Automatically notify support**

No

**Alert Category**

Warning - Temperature

**SNMP Trap ID**

12

**CIM Information**

**Prefix:** PLAT ID: 0491

**User Response**

No action; information only.

- **81010701-1406ffff : Numeric sensor [NumericSensorElementName] going high (upper non-critical) has deasserted. (DIMM GH VR Temp)**

This message is for the use case when an implementation has detected an Upper Non-critical sensor going high has deasserted.

May also be shown as 810107011406ffff or 0x810107011406ffff

**Severity**

Info

**Serviceable**

No

**Automatically notify support**

No

**Alert Category**

Warning - Temperature

**SNMP Trap ID**

12

**CIM Information**

**Prefix:** PLAT ID: 0491

**User Response**

No action; information only.

- **81010701-2d01ffff : Numeric sensor [NumericSensorElementName] going high (upper non-critical) has deasserted. (PCH Temp)**

This message is for the use case when an implementation has detected an Upper Non-critical sensor going high has deasserted.

May also be shown as 810107012d01ffff or 0x810107012d01ffff

**Severity**

Info

**Serviceable**

No

**Automatically notify support**

No

**Alert Category**

Warning - Temperature

**SNMP Trap ID**

12

**CIM Information****Prefix: PLAT ID:** 0491**User Response**

No action; information only.

- **81010701-3701ffff : Numeric sensor [NumericSensorElementName] going high (upper non-critical) has deasserted. (Ambient Temp)**

This message is for the use case when an implementation has detected an Upper Non-critical sensor going high has deasserted.

May also be shown as 810107013701ffff or 0x810107013701ffff

**Severity**

Info

**Serviceable**

No

**Automatically notify support**

No

**Alert Category**

Warning - Temperature

**SNMP Trap ID**

12

**CIM Information****Prefix: PLAT ID:** 0491**User Response**

No action; information only.

- **81010901-0701ffff : Numeric sensor [NumericSensorElementName] going high (upper critical) has deasserted. (RS1 RR Amb Temp)**

This message is for the use case when an implementation has detected an Upper Critical sensor going high has deasserted.

May also be shown as 810109010701ffff or 0x810109010701ffff

**Severity**

Info

**Serviceable**

No

**Automatically notify support**

No

**Alert Category**

Critical - Temperature

**SNMP Trap ID**

0

**CIM Information**

**Prefix:** PLAT ID: 0495

**User Response**

No action; information only.

- **81010901-0702ffff : Numeric sensor [NumericSensorElementName] going high (upper critical) has deasserted. (RS2 RR Amb Temp)**

This message is for the use case when an implementation has detected an Upper Critical sensor going high has deasserted.

May also be shown as 810109010702ffff or 0x810109010702ffff

**Severity**

Info

**Serviceable**

No

**Automatically notify support**

No

**Alert Category**

Critical - Temperature

**SNMP Trap ID**

0

**CIM Information**

**Prefix:** PLAT ID: 0495

**User Response**

No action; information only.

- **81010901-0703ffff : Numeric sensor [NumericSensorElementName] going high (upper critical) has deasserted. (MID1 RR Amb Temp)**

This message is for the use case when an implementation has detected an Upper Critical sensor going high has deasserted.

May also be shown as 810109010703ffff or 0x810109010703ffff

**Severity**

Info

**Serviceable**

No

**Automatically notify support**

No

**Alert Category**

Critical - Temperature

**SNMP Trap ID**

0

**CIM Information**

**Prefix:** PLAT ID: 0495

**User Response**

No action; information only.

- **81010901-0704ffff : Numeric sensor [NumericSensorElementName] going high (upper critical) has deasserted. (MID2 RR Amb Temp)**

This message is for the use case when an implementation has detected an Upper Critical sensor going high has deasserted.

May also be shown as 810109010704ffff or 0x810109010704ffff

**Severity**

Info

**Serviceable**

No

**Automatically notify support**

No

**Alert Category**

Critical - Temperature

**SNMP Trap ID**

0

**CIM Information**

**Prefix: PLAT ID: 0495**

**User Response**

No action; information only.

- **81010901-0705ffff : Numeric sensor [NumericSensorElementName] going high (upper critical) has deasserted. (RAID RR Amb Temp)**

This message is for the use case when an implementation has detected an Upper Critical sensor going high has deasserted.

May also be shown as 810109010705ffff or 0x810109010705ffff

**Severity**

Info

**Serviceable**

No

**Automatically notify support**

No

**Alert Category**

Critical - Temperature

**SNMP Trap ID**

0

**CIM Information**

**Prefix: PLAT ID: 0495**

**User Response**

No action; information only.

- **81010901-0706ffff : Numeric sensor [NumericSensorElementName] going high (upper critical) has deasserted. (PSU FR Amb Temp)**

This message is for the use case when an implementation has detected an Upper Critical sensor going high has deasserted.

May also be shown as 810109010706ffff or 0x810109010706ffff



**Severity**

Info

**Serviceable**

No

**Automatically notify support**

No

**Alert Category**

Critical - Temperature

**SNMP Trap ID**

0

**CIM Information****Prefix: PLAT ID:** 0495**User Response**

No action; information only.

- **81010901-0707ffff : Numeric sensor [NumericSensorElementName] going high (upper critical) has deasserted. (Rear BP1 Temp)**

This message is for the use case when an implementation has detected an Upper Critical sensor going high has deasserted.

May also be shown as 810109010707ffff or 0x810109010707ffff

**Severity**

Info

**Serviceable**

No

**Automatically notify support**

No

**Alert Category**

Critical - Temperature

**SNMP Trap ID**

0

**CIM Information****Prefix: PLAT ID:** 0495**User Response**

No action; information only.

- **81010901-0708ffff : Numeric sensor [NumericSensorElementName] going high (upper critical) has deasserted. (Rear BP2 Temp)**

This message is for the use case when an implementation has detected an Upper Critical sensor going high has deasserted.

May also be shown as 810109010708ffff or 0x810109010708ffff

**Severity**

Info

**Serviceable**

No

**Automatically notify support**

No

**Alert Category**

Critical - Temperature

**SNMP Trap ID**

0

**CIM Information**

Prefix: PLAT ID: 0495

**User Response**

No action; information only.

- **81010901-1401ffff : Numeric sensor [NumericSensorElementName] going high (upper critical) has deasserted. (CPU1 VR Temp)**

This message is for the use case when an implementation has detected an Upper Critical sensor going high has deasserted.

May also be shown as 810109011401ffff or 0x810109011401ffff

**Severity**

Info

**Serviceable**

No

**Automatically notify support**

No

**Alert Category**

Critical - Temperature

**SNMP Trap ID**

0

**CIM Information**

Prefix: PLAT ID: 0495

**User Response**

No action; information only.

- **81010901-1402ffff : Numeric sensor [NumericSensorElementName] going high (upper critical) has deasserted. (CPU2 VR Temp)**

This message is for the use case when an implementation has detected an Upper Critical sensor going high has deasserted.

May also be shown as 810109011402ffff or 0x810109011402ffff

**Severity**

Info

**Serviceable**

No

**Automatically notify support**

No

**Alert Category**

Critical - Temperature

**SNMP Trap ID**

0

**CIM Information**

Prefix: PLAT ID: 0495

**User Response**

No action; information only.

- **81010901-1403ffff : Numeric sensor [NumericSensorElementName] going high (upper critical) has deasserted. (DIMM AB VR Temp)**

This message is for the use case when an implementation has detected an Upper Critical sensor going high has deasserted.

May also be shown as 810109011403ffff or 0x810109011403ffff

**Severity**

Info

**Serviceable**

No

**Automatically notify support**

No

**Alert Category**

Critical - Temperature

**SNMP Trap ID**

0

**CIM Information**

**Prefix:** PLAT ID: 0495

**User Response**

No action; information only.

- **81010901-1404ffff : Numeric sensor [NumericSensorElementName] going high (upper critical) has deasserted. (DIMM CD VR Temp)**

This message is for the use case when an implementation has detected an Upper Critical sensor going high has deasserted.

May also be shown as 810109011404ffff or 0x810109011404ffff

**Severity**

Info

**Serviceable**

No

**Automatically notify support**

No

**Alert Category**

Critical - Temperature

**SNMP Trap ID**

0

**CIM Information**

**Prefix:** PLAT ID: 0495

**User Response**

No action; information only.

- **81010901-1405ffff : Numeric sensor [NumericSensorElementName] going high (upper critical) has deasserted. (DIMM EF VR Temp)**

This message is for the use case when an implementation has detected an Upper Critical sensor going high has deasserted.

May also be shown as 810109011405ffff or 0x810109011405ffff

**Severity**

Info

**Serviceable**

No

**Automatically notify support**

No

**Alert Category**

Critical - Temperature

**SNMP Trap ID**

0

**CIM Information****Prefix: PLAT ID:** 0495**User Response**

No action; information only.

- **81010901-1406ffff : Numeric sensor [NumericSensorElementName] going high (upper critical) has deasserted. (DIMM GH VR Temp)**

This message is for the use case when an implementation has detected an Upper Critical sensor going high has deasserted.

May also be shown as 810109011406ffff or 0x810109011406ffff

**Severity**

Info

**Serviceable**

No

**Automatically notify support**

No

**Alert Category**

Critical - Temperature

**SNMP Trap ID**

0

**CIM Information****Prefix: PLAT ID:** 0495**User Response**

No action; information only.

- **81010901-2d01ffff : Numeric sensor [NumericSensorElementName] going high (upper critical) has deasserted. (PCH Temp)**

This message is for the use case when an implementation has detected an Upper Critical sensor going high has deasserted.

May also be shown as 810109012d01ffff or 0x810109012d01ffff

**Severity**

Info

**Serviceable**

No

**Automatically notify support**

No

**Alert Category**

Critical - Temperature

**SNMP Trap ID**

0

**CIM Information**

**Prefix:** PLAT ID: 0495

**User Response**

No action; information only.

- **81010901-3701ffff : Numeric sensor [NumericSensorElementName] going high (upper critical) has deasserted. (Ambient Temp)**

This message is for the use case when an implementation has detected an Upper Critical sensor going high has deasserted.

May also be shown as 810109013701ffff or 0x810109013701ffff

**Severity**

Info

**Serviceable**

No

**Automatically notify support**

No

**Alert Category**

Critical - Temperature

**SNMP Trap ID**

0

**CIM Information**

**Prefix:** PLAT ID: 0495

**User Response**

No action; information only.

- **81010902-0701ffff : Numeric sensor [NumericSensorElementName] going high (upper critical) has deasserted. (SysBrd 12V)**

This message is for the use case when an implementation has detected an Upper Critical sensor going high has deasserted.

May also be shown as 810109020701ffff or 0x810109020701ffff

**Severity**

Info

**Serviceable**

No

**Automatically notify support**

No

**Alert Category**

Critical - Voltage

**SNMP Trap ID**

1

**CIM Information**

**Prefix:** PLAT ID: 0495

### User Response

No action; information only. SysBrd 3.3V : SysBrd 5V :

- **81010b01-0701ffff : Numeric sensor [NumericSensorElementName] going high (upper non-recoverable) has deasserted. (RS1 RR Amb Temp)**

This message is for the use case when an implementation has detected an Upper Non-recoverable sensor going high has deasserted.

May also be shown as 81010b010701ffff or 0x81010b010701ffff

### Severity

Info

### Serviceable

No

### Automatically notify support

No

### Alert Category

Critical - Temperature

### SNMP Trap ID

0

### CIM Information

Prefix: PLAT ID: 0499

### User Response

No action; information only.

- **81010b01-0702ffff : Numeric sensor [NumericSensorElementName] going high (upper non-recoverable) has deasserted. (RS2 RR Amb Temp)**

This message is for the use case when an implementation has detected an Upper Non-recoverable sensor going high has deasserted.

May also be shown as 81010b010702ffff or 0x81010b010702ffff

### Severity

Info

### Serviceable

No

### Automatically notify support

No

### Alert Category

Critical - Temperature

### SNMP Trap ID

0

### CIM Information

Prefix: PLAT ID: 0499

### User Response

No action; information only.

- **81010b01-0703ffff : Numeric sensor [NumericSensorElementName] going high (upper non-recoverable) has deasserted. (MID1 RR Amb Temp)**

This message is for the use case when an implementation has detected an Upper Non-recoverable sensor going high has deasserted.

May also be shown as 81010b010703ffff or 0x81010b010703ffff

**Severity**

Info

**Serviceable**

No

**Automatically notify support**

No

**Alert Category**

Critical - Temperature

**SNMP Trap ID**

0

**CIM Information****Prefix: PLAT ID:** 0499**User Response**

No action; information only.

- **81010b01-0704ffff : Numeric sensor [NumericSensorElementName] going high (upper non-recoverable) has deasserted. (MID2 RR Amb Temp)**

This message is for the use case when an implementation has detected an Upper Non-recoverable sensor going high has deasserted.

May also be shown as 81010b010704ffff or 0x81010b010704ffff

**Severity**

Info

**Serviceable**

No

**Automatically notify support**

No

**Alert Category**

Critical - Temperature

**SNMP Trap ID**

0

**CIM Information****Prefix: PLAT ID:** 0499**User Response**

No action; information only.

- **81010b01-0705ffff : Numeric sensor [NumericSensorElementName] going high (upper non-recoverable) has deasserted. (RAID RR Amb Temp)**

This message is for the use case when an implementation has detected an Upper Non-recoverable sensor going high has deasserted.

May also be shown as 81010b010705ffff or 0x81010b010705ffff

**Severity**

Info

**Serviceable**

No

**Automatically notify support**

No

**Alert Category**

Critical - Temperature

**SNMP Trap ID**

0

**CIM Information**

Prefix: PLAT ID: 0499

**User Response**

No action; information only.

- **81010b01-0706ffff : Numeric sensor [NumericSensorElementName] going high (upper non-recoverable) has deasserted. (PSU FR Amb Temp)**

This message is for the use case when an implementation has detected an Upper Non-recoverable sensor going high has deasserted.

May also be shown as 81010b010706ffff or 0x81010b010706ffff

**Severity**

Info

**Serviceable**

No

**Automatically notify support**

No

**Alert Category**

Critical - Temperature

**SNMP Trap ID**

0

**CIM Information**

Prefix: PLAT ID: 0499

**User Response**

No action; information only.

- **81010b01-0707ffff : Numeric sensor [NumericSensorElementName] going high (upper non-recoverable) has deasserted. (Rear BP1 Temp)**

This message is for the use case when an implementation has detected an Upper Non-recoverable sensor going high has deasserted.

May also be shown as 81010b010707ffff or 0x81010b010707ffff

**Severity**

Info

**Serviceable**

No

**Automatically notify support**

No

**Alert Category**

Critical - Temperature

**SNMP Trap ID**

0

**CIM Information**

Prefix: PLAT ID: 0499



**User Response**

No action; information only.

- **81010b01-0708ffff : Numeric sensor [NumericSensorElementName] going high (upper non-recoverable) has deasserted. (Rear BP2 Temp)**

This message is for the use case when an implementation has detected an Upper Non-recoverable sensor going high has deasserted.

May also be shown as 81010b010708ffff or 0x81010b010708ffff

**Severity**

Info

**Serviceable**

No

**Automatically notify support**

No

**Alert Category**

Critical - Temperature

**SNMP Trap ID**

0

**CIM Information**

Prefix: PLAT ID: 0499

**User Response**

No action; information only.

- **81010b01-1401ffff : Numeric sensor [NumericSensorElementName] going high (upper non-recoverable) has deasserted. (CPU1 VR Temp)**

This message is for the use case when an implementation has detected an Upper Non-recoverable sensor going high has deasserted.

May also be shown as 81010b011401ffff or 0x81010b011401ffff

**Severity**

Info

**Serviceable**

No

**Automatically notify support**

No

**Alert Category**

Critical - Temperature

**SNMP Trap ID**

0

**CIM Information**

Prefix: PLAT ID: 0499

**User Response**

No action; information only.

- **81010b01-1402ffff : Numeric sensor [NumericSensorElementName] going high (upper non-recoverable) has deasserted. (CPU2 VR Temp)**

This message is for the use case when an implementation has detected an Upper Non-recoverable sensor going high has deasserted.

May also be shown as 81010b011402ffff or 0x81010b011402ffff

**Severity**

Info

**Serviceable**

No

**Automatically notify support**

No

**Alert Category**

Critical - Temperature

**SNMP Trap ID**

0

**CIM Information****Prefix: PLAT ID:** 0499**User Response**

No action; information only.

- **81010b01-1403ffff : Numeric sensor [NumericSensorElementName] going high (upper non-recoverable) has deasserted. (DIMM AB VR Temp)**

This message is for the use case when an implementation has detected an Upper Non-recoverable sensor going high has deasserted.

May also be shown as 81010b011403ffff or 0x81010b011403ffff

**Severity**

Info

**Serviceable**

No

**Automatically notify support**

No

**Alert Category**

Critical - Temperature

**SNMP Trap ID**

0

**CIM Information****Prefix: PLAT ID:** 0499**User Response**

No action; information only.

- **81010b01-1404ffff : Numeric sensor [NumericSensorElementName] going high (upper non-recoverable) has deasserted. (DIMM CD VR Temp)**

This message is for the use case when an implementation has detected an Upper Non-recoverable sensor going high has deasserted.

May also be shown as 81010b011404ffff or 0x81010b011404ffff

**Severity**

Info

**Serviceable**

No

**Automatically notify support**

No

**Alert Category**

Critical - Temperature

**SNMP Trap ID**

0

**CIM Information**

**Prefix:** PLAT ID: 0499

**User Response**

No action; information only.

- **81010b01-1405ffff : Numeric sensor [NumericSensorElementName] going high (upper non-recoverable) has deasserted. (DIMM EF VR Temp)**

This message is for the use case when an implementation has detected an Upper Non-recoverable sensor going high has deasserted.

May also be shown as 81010b011405ffff or 0x81010b011405ffff

**Severity**

Info

**Serviceable**

No

**Automatically notify support**

No

**Alert Category**

Critical - Temperature

**SNMP Trap ID**

0

**CIM Information**

**Prefix:** PLAT ID: 0499

**User Response**

No action; information only.

- **81010b01-1406ffff : Numeric sensor [NumericSensorElementName] going high (upper non-recoverable) has deasserted. (DIMM GH VR Temp)**

This message is for the use case when an implementation has detected an Upper Non-recoverable sensor going high has deasserted.

May also be shown as 81010b011406ffff or 0x81010b011406ffff

**Severity**

Info

**Serviceable**

No

**Automatically notify support**

No

**Alert Category**

Critical - Temperature

**SNMP Trap ID**

0

**CIM Information**

**Prefix:** PLAT ID: 0499

**User Response**

No action; information only.

- **81010b01-2d01ffff : Numeric sensor [NumericSensorElementName] going high (upper non-recoverable) has deasserted. (PCH Temp)**

This message is for the use case when an implementation has detected an Upper Non-recoverable sensor going high has deasserted.

May also be shown as 81010b012d01ffff or 0x81010b012d01ffff

**Severity**

Info

**Serviceable**

No

**Automatically notify support**

No

**Alert Category**

Critical - Temperature

**SNMP Trap ID**

0

**CIM Information**

Prefix: PLAT ID: 0499

**User Response**

No action; information only.

- **81010b01-3701ffff : Numeric sensor [NumericSensorElementName] going high (upper non-recoverable) has deasserted. (Ambient Temp)**

This message is for the use case when an implementation has detected an Upper Non-recoverable sensor going high has deasserted.

May also be shown as 81010b013701ffff or 0x81010b013701ffff

**Severity**

Info

**Serviceable**

No

**Automatically notify support**

No

**Alert Category**

Critical - Temperature

**SNMP Trap ID**

0

**CIM Information**

Prefix: PLAT ID: 0499

**User Response**

No action; information only.

- **81030006-2101ffff : Sensor [SensorElementName] has asserted. (Sig Verify Fail)**

This message is for the use case when an implementation has detected a Sensor has asserted.

May also be shown as 810300062101ffff or 0x810300062101ffff

**Severity**

Info

**Serviceable**

No

**Automatically notify support**

No

**Alert Category**

System - Other

**SNMP Trap ID**

**CIM Information**

**Prefix:** PLAT ID: 0508

**User Response**

No action; information only.

- **81030012-2301ffff : Sensor [SensorElementName] has asserted. (OS RealTime Mod)**

This message is for the use case when an implementation has detected a Sensor has asserted.

May also be shown as 810300122301ffff or 0x810300122301ffff

**Severity**

Info

**Serviceable**

No

**Automatically notify support**

No

**Alert Category**

System - Other

**SNMP Trap ID**

**CIM Information**

**Prefix:** PLAT ID: 0508

**User Response**

No action; information only.

- **81030021-0782ffff : Sensor [SensorElementName] has asserted. (PCIe Dev LK Down)**

This message is for the use case when an implementation has detected a Sensor has asserted.

May also be shown as 810300210782ffff or 0x810300210782ffff

**Severity**

Info

**Serviceable**

No

**Automatically notify support**

No

**Alert Category**

System - Other

**SNMP Trap ID**

**CIM Information**

Prefix: PLAT ID: 0508

**User Response**

No action; information only.

- **81030108-1301ffff : Sensor [SensorElementName] has deasserted. (PS Heavy Load)**

This message is for the use case when an implementation has detected a Sensor has deasserted.

May also be shown as 810301081301ffff or 0x810301081301ffff

**Severity**

Info

**Serviceable**

No

**Automatically notify support**

No

**Alert Category**

System - Other

**SNMP Trap ID****CIM Information**

Prefix: PLAT ID: 0509

**User Response**

No action; information only.

- **8103010c-2581ffff : Sensor [SensorElementName] has deasserted. (Non-Auth DIMMs)**

This message is for the use case when an implementation has detected a Sensor has deasserted.

May also be shown as 8103010c2581ffff or 0x8103010c2581ffff

**Severity**

Info

**Serviceable**

No

**Automatically notify support**

No

**Alert Category**

System - Other

**SNMP Trap ID****CIM Information**

Prefix: PLAT ID: 0509

**User Response**

No action; information only.

- **81030112-0601ffff : Sensor [SensorElementName] has deasserted. (SMM Mode)**

This message is for the use case when an implementation has detected a Sensor has deasserted.

May also be shown as 810301120601ffff or 0x810301120601ffff

**Severity**

Info

**Serviceable**

No

**Automatically notify support**

No

**Alert Category**

System - Other

**SNMP Trap ID****CIM Information**

Prefix: PLAT ID: 0509

**User Response**

No action; information only. SMM Monitor :

- **81030121-0782ffff : Sensor [SensorElementName] has deasserted. (PCIe Dev LK Down)**

This message is for the use case when an implementation has detected a Sensor has deasserted.

May also be shown as 810301210782ffff or 0x810301210782ffff

**Severity**

Info

**Serviceable**

No

**Automatically notify support**

No

**Alert Category**

System - Other

**SNMP Trap ID****CIM Information**

Prefix: PLAT ID: 0509

**User Response**

No action; information only.

- **81070101-0c01ffff : Sensor [SensorElementName] has deasserted the transition from normal to non-critical state. (Ambient Status)**

This message is for the use case when an implementation has detected that a Sensor has deasserted a transition to non-critical from normal.

May also be shown as 810701010c01ffff or 0x810701010c01ffff

**Severity**

Info

**Serviceable**

No

**Automatically notify support**

No

**Alert Category**

Warning - Temperature

**SNMP Trap ID**

12

**CIM Information**

Prefix: PLAT ID: 0521

**User Response**

No action; information only.

- **81070101-2c01ffff : Sensor [SensorElementName] has deasserted the transition from normal to non-critical state. (ML2 OverTemp)**

This message is for the use case when an implementation has detected that a Sensor has deasserted a transition to non-critical from normal.

May also be shown as 810701012c01ffff or 0x810701012c01ffff

**Severity**

Info

**Serviceable**

No

**Automatically notify support**

No

**Alert Category**

Warning - Temperature

**SNMP Trap ID**

12

**CIM Information**

Prefix: PLAT ID: 0521

**User Response**

No action; information only.

- **8107010d-2582ffff : Sensor [SensorElementName] has deasserted the transition from normal to non-critical state. (RAID Vol State)**

This message is for the use case when an implementation has detected that a Sensor has deasserted a transition to non-critical from normal.

May also be shown as 8107010d2582ffff or 0x8107010d2582ffff

**Severity**

Info

**Serviceable**

No

**Automatically notify support**

No

**Alert Category**

Warning - Other

**SNMP Trap ID**

60

**CIM Information**

Prefix: PLAT ID: 0521

**User Response**

No action; information only.

- **8107010f-2201ffff : Sensor [SensorElementName] has deasserted the transition from normal to non-critical state. (GPT Status)**



This message is for the use case when an implementation has detected that a Sensor has deasserted a transition to non-critical from normal.

May also be shown as 8107010f2201ffff or 0x8107010f2201ffff

**Severity**

Info

**Serviceable**

No

**Automatically notify support**

No

**Alert Category**

Warning - Other

**SNMP Trap ID**

60

**CIM Information**

Prefix: PLAT ID: 0521

**User Response**

No action; information only.

- **8107010f-2582ffff : Sensor [SensorElementName] has deasserted the transition from normal to non-critical state. (I/O Resources)**

This message is for the use case when an implementation has detected that a Sensor has deasserted a transition to non-critical from normal.

May also be shown as 8107010f2582ffff or 0x8107010f2582ffff

**Severity**

Info

**Serviceable**

No

**Automatically notify support**

No

**Alert Category**

Warning - Other

**SNMP Trap ID**

60

**CIM Information**

Prefix: PLAT ID: 0521

**User Response**

No action; information only.

- **81070125-2583ffff : Sensor [SensorElementName] has deasserted the transition from normal to non-critical state. (X8 PCI 1 Config)**

This message is for the use case when an implementation has detected that a Sensor has deasserted a transition to non-critical from normal.

May also be shown as 810701252583ffff or 0x810701252583ffff

**Severity**

Info

**Serviceable**

No

**Automatically notify support**

No

**Alert Category**

Warning - Other

**SNMP Trap ID**

60

**CIM Information**

Prefix: PLAT ID: 0521

**User Response**

No action; information only. X8 PCI 2 Config : X8 PCI 6 Config : X8 PCI 7 Config :

- **81070128-2e01ffff : Sensor [SensorElementName] has deasserted the transition from normal to non-critical state. (ME Recovery)**

This message is for the use case when an implementation has detected that a Sensor has deasserted a transition to non-critical from normal.

May also be shown as 810701282e01ffff or 0x810701282e01ffff

**Severity**

Info

**Serviceable**

No

**Automatically notify support**

No

**Alert Category**

Warning - Other

**SNMP Trap ID**

60

**CIM Information**

Prefix: PLAT ID: 0521

**User Response**

No action; information only.

- **81070201-0301ffff : Sensor [SensorElementName] has transitioned to a less severe state from critical. (CPU 1 OverTemp)**

This message is for the use case when an implementation has detected a Sensor transition to less severe from critical.

May also be shown as 810702010301ffff or 0x810702010301ffff

**Severity**

Info

**Serviceable**

No

**Automatically notify support**

No

**Alert Category**

Critical - Temperature

**SNMP Trap ID**

0

**CIM Information**

**Prefix:** PLAT ID: 0523

**User Response**

No action; information only.

- **81070201-0302ffff : Sensor [SensorElementName] has transitioned to a less severe state from critical. (CPU 2 OverTemp)**

This message is for the use case when an implementation has detected a Sensor transition to less severe from critical.

May also be shown as 810702010302ffff or 0x810702010302ffff

**Severity**

Info

**Serviceable**

No

**Automatically notify support**

No

**Alert Category**

Critical - Temperature

**SNMP Trap ID**

0

**CIM Information**

**Prefix:** PLAT ID: 0523

**User Response**

No action; information only.

- **81070201-1101ffff : Sensor [SensorElementName] has transitioned to a less severe state from critical. (PCI 1 Temp)**

This message is for the use case when an implementation has detected a Sensor transition to less severe from critical.

May also be shown as 810702011101ffff or 0x810702011101ffff

**Severity**

Info

**Serviceable**

No

**Automatically notify support**

No

**Alert Category**

Critical - Temperature

**SNMP Trap ID**

0

**CIM Information**

**Prefix:** PLAT ID: 0523

**User Response**

No action; information only.

- **81070201-1102ffff : Sensor [SensorElementName] has transitioned to a less severe state from critical. (PCI 2 Temp)**

This message is for the use case when an implementation has detected a Sensor transition to less severe from critical.

May also be shown as 810702011102ffff or 0x810702011102ffff

**Severity**

Info

**Serviceable**

No

**Automatically notify support**

No

**Alert Category**

Critical - Temperature

**SNMP Trap ID**

0

**CIM Information**

Prefix: PLAT ID: 0523

**User Response**

No action; information only.

- **81070201-1103ffff : Sensor [SensorElementName] has transitioned to a less severe state from critical. (PCI 3 Temp)**

This message is for the use case when an implementation has detected a Sensor transition to less severe from critical.

May also be shown as 810702011103ffff or 0x810702011103ffff

**Severity**

Info

**Serviceable**

No

**Automatically notify support**

No

**Alert Category**

Critical - Temperature

**SNMP Trap ID**

0

**CIM Information**

Prefix: PLAT ID: 0523

**User Response**

No action; information only.

- **81070201-1104ffff : Sensor [SensorElementName] has transitioned to a less severe state from critical. (PCI 4 Temp)**

This message is for the use case when an implementation has detected a Sensor transition to less severe from critical.

May also be shown as 810702011104ffff or 0x810702011104ffff

**Severity**

Info

**Serviceable**

No

**Automatically notify support**

No

**Alert Category**

Critical - Temperature

**SNMP Trap ID**

0

**CIM Information**

**Prefix: PLAT ID:** 0523

**User Response**

No action; information only.

- **81070201-1105ffff : Sensor [SensorElementName] has transitioned to a less severe state from critical. (PCI 5 Temp)**

This message is for the use case when an implementation has detected a Sensor transition to less severe from critical.

May also be shown as 810702011105ffff or 0x810702011105ffff

**Severity**

Info

**Serviceable**

No

**Automatically notify support**

No

**Alert Category**

Critical - Temperature

**SNMP Trap ID**

0

**CIM Information**

**Prefix: PLAT ID:** 0523

**User Response**

No action; information only.

- **81070201-1106ffff : Sensor [SensorElementName] has transitioned to a less severe state from critical. (PCI 6 Temp)**

This message is for the use case when an implementation has detected a Sensor transition to less severe from critical.

May also be shown as 810702011106ffff or 0x810702011106ffff

**Severity**

Info

**Serviceable**

No

**Automatically notify support**

No

**Alert Category**

Critical - Temperature

**SNMP Trap ID**

0

**CIM Information**

**Prefix:** PLAT ID: 0523

**User Response**

No action; information only.

- **81070201-1107ffff : Sensor [SensorElementName] has transitioned to a less severe state from critical. (PCI 7 Temp)**

This message is for the use case when an implementation has detected a Sensor transition to less severe from critical.

May also be shown as 810702011107ffff or 0x810702011107ffff

**Severity**

Info

**Serviceable**

No

**Automatically notify support**

No

**Alert Category**

Critical - Temperature

**SNMP Trap ID**

0

**CIM Information**

**Prefix:** PLAT ID: 0523

**User Response**

No action; information only.

- **81070201-1108ffff : Sensor [SensorElementName] has transitioned to a less severe state from critical. (PCI 8 Temp)**

This message is for the use case when an implementation has detected a Sensor transition to less severe from critical.

May also be shown as 810702011108ffff or 0x810702011108ffff

**Severity**

Info

**Serviceable**

No

**Automatically notify support**

No

**Alert Category**

Critical - Temperature

**SNMP Trap ID**

0

**CIM Information**

**Prefix:** PLAT ID: 0523

**User Response**

No action; information only.

- **81070202-0701ffff : Sensor [SensorElementName] has transitioned to a less severe state from critical. (SysBrd Vol Fault)**

This message is for the use case when an implementation has detected a Sensor transition to less severe from critical.

May also be shown as 810702020701ffff or 0x810702020701ffff

**Severity**

Info

**Serviceable**

No

**Automatically notify support**

No

**Alert Category**

Critical - Voltage

**SNMP Trap ID**

1

**CIM Information**

**Prefix:** PLAT ID: 0523

**User Response**

No action; information only.

- **81070204-0a01ffff : Sensor [SensorElementName] has transitioned to a less severe state from critical. (PS 1 Fan Fault)**

This message is for the use case when an implementation has detected a Sensor transition to less severe from critical.

May also be shown as 810702040a01ffff or 0x810702040a01ffff

**Severity**

Info

**Serviceable**

No

**Automatically notify support**

No

**Alert Category**

Critical - Fan Failure

**SNMP Trap ID**

11

**CIM Information**

**Prefix:** PLAT ID: 0523

**User Response**

No action; information only.

- **81070204-0a02ffff : Sensor [SensorElementName] has transitioned to a less severe state from critical. (PS 2 Fan Fault)**

This message is for the use case when an implementation has detected a Sensor transition to less severe from critical.

May also be shown as 810702040a02ffff or 0x810702040a02ffff

**Severity**

Info

**Serviceable**

No

**Automatically notify support**

No

**Alert Category**

Critical - Fan Failure

**SNMP Trap ID**

11

**CIM Information****Prefix: PLAT ID:** 0523**User Response**

No action; information only.

- **81070208-0a01ffff : Sensor [SensorElementName] has transitioned to a less severe state from critical. (PS 1 Therm Fault)**

This message is for the use case when an implementation has detected a Sensor transition to less severe from critical.

May also be shown as 810702080a01ffff or 0x810702080a01ffff

**Severity**

Info

**Serviceable**

No

**Automatically notify support**

No

**Alert Category**

Critical - Power

**SNMP Trap ID**

4

**CIM Information****Prefix: PLAT ID:** 0523**User Response**

No action; information only.

- **81070208-0a02ffff : Sensor [SensorElementName] has transitioned to a less severe state from critical. (PS 2 Therm Fault)**

This message is for the use case when an implementation has detected a Sensor transition to less severe from critical.

May also be shown as 810702080a02ffff or 0x810702080a02ffff

**Severity**

Info

**Serviceable**

No

**Automatically notify support**

No



**Alert Category**

Critical - Power

**SNMP Trap ID**

4

**CIM Information**

**Prefix:** PLAT ID: 0523

**User Response**

No action; information only.

- **8107020c-2585ffff : Sensor [SensorElementName] has transitioned to a less severe state from critical. (nvDIMM Status)**

This message is for the use case when an implementation has detected a Sensor transition to less severe from critical.

May also be shown as 8107020c2585ffff or 0x8107020c2585ffff

**Severity**

Info

**Serviceable**

No

**Automatically notify support**

No

**Alert Category**

Critical - Other

**SNMP Trap ID**

50

**CIM Information**

**Prefix:** PLAT ID: 0523

**User Response**

No action; information only.

- **8107020d-2582ffff : Sensor [SensorElementName] has transitioned to a less severe state from critical. (RAID Vol State)**

This message is for the use case when an implementation has detected a Sensor transition to less severe from critical.

May also be shown as 8107020d2582ffff or 0x8107020d2582ffff

**Severity**

Info

**Serviceable**

No

**Automatically notify support**

No

**Alert Category**

Critical - Other

**SNMP Trap ID**

50

**CIM Information**

**Prefix:** PLAT ID: 0523

**User Response**

No action; information only.

- **8107020f-2201ffff : Sensor [SensorElementName] has transitioned to a less severe state from critical. (TXT ACM Module)**

This message is for the use case when an implementation has detected a Sensor transition to less severe from critical.

May also be shown as 8107020f2201ffff or 0x8107020f2201ffff

**Severity**

Info

**Serviceable**

No

**Automatically notify support**

No

**Alert Category**

Critical - Other

**SNMP Trap ID**

50

**CIM Information**

**Prefix: PLAT ID: 0523**

**User Response**

No action; information only. nvDIMM Flash :

- **8107020f-2582ffff : Sensor [SensorElementName] has transitioned to a less severe state from critical. (I/O Resources)**

This message is for the use case when an implementation has detected a Sensor transition to less severe from critical.

May also be shown as 8107020f2582ffff or 0x8107020f2582ffff

**Severity**

Info

**Serviceable**

No

**Automatically notify support**

No

**Alert Category**

Critical - Other

**SNMP Trap ID**

50

**CIM Information**

**Prefix: PLAT ID: 0523**

**User Response**

No action; information only.

- **81070214-2201ffff : Sensor [SensorElementName] has transitioned to a less severe state from critical. (TPM Lock)**

This message is for the use case when an implementation has detected a Sensor transition to less severe from critical.

May also be shown as 810702142201ffff or 0x810702142201ffff

**Severity**

Info

**Serviceable**

No

**Automatically notify support**

No

**Alert Category**

Critical - Other

**SNMP Trap ID**

50

**CIM Information****Prefix: PLAT ID:** 0523**User Response**

No action; information only.

- **81070219-0701ffff : Sensor [SensorElementName] has transitioned to a less severe state from critical. (SysBrd Fault)**

This message is for the use case when an implementation has detected a Sensor transition to less severe from critical.

May also be shown as 810702190701ffff or 0x810702190701ffff

**Severity**

Info

**Serviceable**

No

**Automatically notify support**

No

**Alert Category**

Critical - Other

**SNMP Trap ID**

50

**CIM Information****Prefix: PLAT ID:** 0523**User Response**

No action; information only.

- **8107021b-0301ffff : Sensor [SensorElementName] has transitioned to a less severe state from critical. (CPU 1 QPILinkErr)**

This message is for the use case when an implementation has detected a Sensor transition to less severe from critical.

May also be shown as 8107021b0301ffff or 0x8107021b0301ffff

**Severity**

Info

**Serviceable**

No

**Automatically notify support**

No

**Alert Category**

Critical - Other

**SNMP Trap ID**

50

**CIM Information**

Prefix: PLAT ID: 0523

**User Response**

No action; information only.

- **8107021b-0302ffff : Sensor [SensorElementName] has transitioned to a less severe state from critical. (CPU 2 QPILinkErr)**

This message is for the use case when an implementation has detected a Sensor transition to less severe from critical.

May also be shown as 8107021b0302ffff or 0x8107021b0302ffff

**Severity**

Info

**Serviceable**

No

**Automatically notify support**

No

**Alert Category**

Critical - Other

**SNMP Trap ID**

50

**CIM Information**

Prefix: PLAT ID: 0523

**User Response**

No action; information only.

- **81070228-2e01ffff : Sensor [SensorElementName] has transitioned to a less severe state from critical. (ME Error)**

This message is for the use case when an implementation has detected a Sensor transition to less severe from critical.

May also be shown as 810702282e01ffff or 0x810702282e01ffff

**Severity**

Info

**Serviceable**

No

**Automatically notify support**

No

**Alert Category**

Critical - Other

**SNMP Trap ID**

50

**CIM Information**

Prefix: PLAT ID: 0523

**User Response**

No action; information only. ME Flash Error :

- **81070301-0301ffff : Sensor [SensorElementName] has deasserted the transition to non-recoverable from a less severe state. (CPU 1 OverTemp)**

This message is for the use case when an implementation has detected that the Sensor transition to non-recoverable from less severe has deasserted.

May also be shown as 810703010301ffff or 0x810703010301ffff

**Severity**

Info

**Serviceable**

No

**Automatically notify support**

No

**Alert Category**

Critical - Temperature

**SNMP Trap ID**

0

**CIM Information**

**Prefix: PLAT ID: 0525**

**User Response**

No action; information only.

- **81070301-0302ffff : Sensor [SensorElementName] has deasserted the transition to non-recoverable from a less severe state. (CPU 2 OverTemp)**

This message is for the use case when an implementation has detected that the Sensor transition to non-recoverable from less severe has deasserted.

May also be shown as 810703010302ffff or 0x810703010302ffff

**Severity**

Info

**Serviceable**

No

**Automatically notify support**

No

**Alert Category**

Critical - Temperature

**SNMP Trap ID**

0

**CIM Information**

**Prefix: PLAT ID: 0525**

**User Response**

No action; information only.

- **81070301-1101ffff : Sensor [SensorElementName] has deasserted the transition to non-recoverable from a less severe state. (PCI 1 Temp)**

This message is for the use case when an implementation has detected that the Sensor transition to non-recoverable from less severe has deasserted.

May also be shown as 810703011101ffff or 0x810703011101ffff

**Severity**

Info

**Serviceable**

No

**Automatically notify support**

No

**Alert Category**

Critical - Temperature

**SNMP Trap ID**

0

**CIM Information****Prefix: PLAT ID:** 0525**User Response**

No action; information only.

- **81070301-1102ffff : Sensor [SensorElementName] has deasserted the transition to non-recoverable from a less severe state. (PCI 2 Temp)**

This message is for the use case when an implementation has detected that the Sensor transition to non-recoverable from less severe has deasserted.

May also be shown as 810703011102ffff or 0x810703011102ffff

**Severity**

Info

**Serviceable**

No

**Automatically notify support**

No

**Alert Category**

Critical - Temperature

**SNMP Trap ID**

0

**CIM Information****Prefix: PLAT ID:** 0525**User Response**

No action; information only.

- **81070301-1103ffff : Sensor [SensorElementName] has deasserted the transition to non-recoverable from a less severe state. (PCI 3 Temp)**

This message is for the use case when an implementation has detected that the Sensor transition to non-recoverable from less severe has deasserted.

May also be shown as 810703011103ffff or 0x810703011103ffff

**Severity**

Info

**Serviceable**

No

**Automatically notify support**

No

**Alert Category**

Critical - Temperature

**SNMP Trap ID**

0

**CIM Information**

**Prefix:** PLAT ID: 0525

**User Response**

No action; information only.

- **81070301-1104ffff : Sensor [SensorElementName] has deasserted the transition to non-recoverable from a less severe state. (PCI 4 Temp)**

This message is for the use case when an implementation has detected that the Sensor transition to non-recoverable from less severe has deasserted.

May also be shown as 810703011104ffff or 0x810703011104ffff

**Severity**

Info

**Serviceable**

No

**Automatically notify support**

No

**Alert Category**

Critical - Temperature

**SNMP Trap ID**

0

**CIM Information**

**Prefix:** PLAT ID: 0525

**User Response**

No action; information only.

- **81070301-1105ffff : Sensor [SensorElementName] has deasserted the transition to non-recoverable from a less severe state. (PCI 5 Temp)**

This message is for the use case when an implementation has detected that the Sensor transition to non-recoverable from less severe has deasserted.

May also be shown as 810703011105ffff or 0x810703011105ffff

**Severity**

Info

**Serviceable**

No

**Automatically notify support**

No

**Alert Category**

Critical - Temperature

**SNMP Trap ID**

0

**CIM Information**

**Prefix:** PLAT ID: 0525

**User Response**

No action; information only.

- **81070301-1106ffff : Sensor [SensorElementName] has deasserted the transition to non-recoverable from a less severe state. (PCI 6 Temp)**

This message is for the use case when an implementation has detected that the Sensor transition to non-recoverable from less severe has deasserted.

May also be shown as 810703011106ffff or 0x810703011106ffff

**Severity**

Info

**Serviceable**

No

**Automatically notify support**

No

**Alert Category**

Critical - Temperature

**SNMP Trap ID**

0

**CIM Information**

Prefix: PLAT ID: 0525

**User Response**

No action; information only.

- **81070301-1107ffff : Sensor [SensorElementName] has deasserted the transition to non-recoverable from a less severe state. (PCI 7 Temp)**

This message is for the use case when an implementation has detected that the Sensor transition to non-recoverable from less severe has deasserted.

May also be shown as 810703011107ffff or 0x810703011107ffff

**Severity**

Info

**Serviceable**

No

**Automatically notify support**

No

**Alert Category**

Critical - Temperature

**SNMP Trap ID**

0

**CIM Information**

Prefix: PLAT ID: 0525

**User Response**

No action; information only.

- **81070301-1108ffff : Sensor [SensorElementName] has deasserted the transition to non-recoverable from a less severe state. (PCI 8 Temp)**

This message is for the use case when an implementation has detected that the Sensor transition to non-recoverable from less severe has deasserted.

May also be shown as 810703011108ffff or 0x810703011108ffff



**Severity**

Info

**Serviceable**

No

**Automatically notify support**

No

**Alert Category**

Critical - Temperature

**SNMP Trap ID**

0

**CIM Information****Prefix: PLAT ID:** 0525**User Response**

No action; information only.

- **81070301-2c01ffff : Sensor [SensorElementName] has deasserted the transition to non-recoverable from a less severe state. (ML2 OverTemp)**

This message is for the use case when an implementation has detected that the Sensor transition to non-recoverable from less severe has deasserted.

May also be shown as 810703012c01ffff or 0x810703012c01ffff

**Severity**

Info

**Serviceable**

No

**Automatically notify support**

No

**Alert Category**

Critical - Temperature

**SNMP Trap ID**

0

**CIM Information****Prefix: PLAT ID:** 0525**User Response**

No action; information only.

- **8107030d-2582ffff : Sensor [SensorElementName] has deasserted the transition to non-recoverable from a less severe state. (RAID Vol State)**

This message is for the use case when an implementation has detected that the Sensor transition to non-recoverable from less severe has deasserted.

May also be shown as 8107030d2582ffff or 0x8107030d2582ffff

**Severity**

Info

**Serviceable**

No

**Automatically notify support**

No

**Alert Category**

Critical - Other

**SNMP Trap ID**

50

**CIM Information**

Prefix: PLAT ID: 0525

**User Response**

No action; information only.

- **81070608-0a01ffff : Sensor [SensorElementName] has deasserted the transition to non-recoverable. (PS1 12V OC Fault)**

This message is for the use case when an implementation has detected that the Sensor transition to non-recoverable has deasserted.

May also be shown as 810706080a01ffff or 0x810706080a01ffff

**Severity**

Info

**Serviceable**

No

**Automatically notify support**

No

**Alert Category**

Critical - Power

**SNMP Trap ID**

4

**CIM Information**

Prefix: PLAT ID: 0531

**User Response**

No action; information only. PS1 12V OV Fault : PS1 12V UV Fault : PS1 12Vaux Fault :

- **81070608-0a02ffff : Sensor [SensorElementName] has deasserted the transition to non-recoverable. (PS2 12V OC Fault)**

This message is for the use case when an implementation has detected that the Sensor transition to non-recoverable has deasserted.

May also be shown as 810706080a02ffff or 0x810706080a02ffff

**Severity**

Info

**Serviceable**

No

**Automatically notify support**

No

**Alert Category**

Critical - Power

**SNMP Trap ID**

4

**CIM Information**

Prefix: PLAT ID: 0531

**User Response**

No action; information only. PS2 12V OV Fault : PS2 12V UV Fault : PS2 12Vaux Fault :

- **81070625-2583ffff : Sensor [SensorElementName] has deasserted the transition to non-recoverable. (X8 PCI 1 Config)**

This message is for the use case when an implementation has detected that the Sensor transition to non-recoverable has deasserted.

May also be shown as 810706252583ffff or 0x810706252583ffff

**Severity**

Info

**Serviceable**

No

**Automatically notify support**

No

**Alert Category**

Critical - Other

**SNMP Trap ID**

50

**CIM Information**

**Prefix:** PLAT ID: 0531

**User Response**

No action; information only. X8 PCI 2 Config : X8 PCI 6 Config : X8 PCI 7 Config :

- **810b010a-1e81ffff : Redundancy Lost for [RedundancySetElementName] has deasserted. (Fan Zone 1)**

This message is for the use case when Redundancy Lost has deasserted.

May also be shown as 810b010a1e81ffff or 0x810b010a1e81ffff

**Severity**

Info

**Serviceable**

No

**Automatically notify support**

No

**Alert Category**

Critical - Fan Failure

**SNMP Trap ID**

11

**CIM Information**

**Prefix:** PLAT ID: 0803

**User Response**

No action; information only.

- **810b010a-1e82ffff : Redundancy Lost for [RedundancySetElementName] has deasserted. (Fan Zone 2)**

This message is for the use case when Redundancy Lost has deasserted.

May also be shown as 810b010a1e82ffff or 0x810b010a1e82ffff

**Severity**

Info

**Serviceable**

No

**Automatically notify support**

No

**Alert Category**

Critical - Fan Failure

**SNMP Trap ID**

11

**CIM Information**

**Prefix:** PLAT ID: 0803

**User Response**

No action; information only.

- **810b010a-1e83ffff : Redundancy Lost for [RedundancySetElementName] has deasserted. (Fan Zone 3)**

This message is for the use case when Redundacy Lost has deasserted.

May also be shown as 810b010a1e83ffff or 0x810b010a1e83ffff

**Severity**

Info

**Serviceable**

No

**Automatically notify support**

No

**Alert Category**

Critical - Fan Failure

**SNMP Trap ID**

11

**CIM Information**

**Prefix:** PLAT ID: 0803

**User Response**

No action; information only.

- **810b010a-1e84ffff : Redundancy Lost for [RedundancySetElementName] has deasserted. (Fan Zone 4)**

This message is for the use case when Redundacy Lost has deasserted.

May also be shown as 810b010a1e84ffff or 0x810b010a1e84ffff

**Severity**

Info

**Serviceable**

No

**Automatically notify support**

No

**Alert Category**

Critical - Fan Failure

**SNMP Trap ID**

11

**CIM Information****Prefix:** PLAT ID: 0803**User Response**

No action; information only.

- **810b010c-2581ffff : Redundancy Lost for [RedundancySetElementName] has deasserted. (Backup Memory)**

This message is for the use case when Redundancy Lost has deasserted.

May also be shown as 810b010c2581ffff or 0x810b010c2581ffff

**Severity**

Info

**Serviceable**

No

**Automatically notify support**

No

**Alert Category**

Critical - Memory

**SNMP Trap ID**

41

**CIM Information****Prefix:** PLAT ID: 0803**User Response**

No action; information only.

- **810b0309-1301ffff : Non-redundant:Sufficient Resources from Redundancy Degraded or Fully Redundant for [RedundancySetElementName] has deasserted. (Power Resource)**

This message is for the use case when a Redundancy Set has transitioned from Non-redundant:Sufficient Resources.

May also be shown as 810b03091301ffff or 0x810b03091301ffff

**Severity**

Info

**Serviceable**

No

**Automatically notify support**

No

**Alert Category**

Warning - Redundant Power Supply

**SNMP Trap ID**

10

**CIM Information****Prefix:** PLAT ID: 0807**User Response**

No action; information only.

- **810b030c-2581ffff : Non-redundant:Sufficient Resources from Redundancy Degraded or Fully Redundant for [RedundancySetElementName] has deasserted. (Backup Memory)**

This message is for the use case when a Redundancy Set has transitioned from Non-redundant:Sufficient Resources.

May also be shown as 810b030c2581ffff or 0x810b030c2581ffff

**Severity**

Info

**Serviceable**

No

**Automatically notify support**

No

**Alert Category**

Warning - Memory

**SNMP Trap ID**

43

**CIM Information**

Prefix: PLAT ID: 0807

**User Response**

No action; information only.

- **810b0509-1301ffff : Non-redundant:Insufficient Resources for [RedundancySetElementName] has deasserted. (Power Resource)**

This message is for the use case when a Redundancy Set has transitioned from Non-redundant: Insufficient Resources.

May also be shown as 810b05091301ffff or 0x810b05091301ffff

**Severity**

Info

**Serviceable**

No

**Automatically notify support**

No

**Alert Category**

Critical - Redundant Power Supply

**SNMP Trap ID**

9

**CIM Information**

Prefix: PLAT ID: 0811

**User Response**

No action; information only.

- **810b050a-1e81ffff : Non-redundant:Insufficient Resources for [RedundancySetElementName] has deasserted. (Fan Zone 1)**

This message is for the use case when a Redundancy Set has transitioned from Non-redundant: Insufficient Resources.

May also be shown as 810b050a1e81ffff or 0x810b050a1e81ffff

**Severity**

Info

**Serviceable**

No

**Automatically notify support**

No

**Alert Category**

Critical - Fan Failure

**SNMP Trap ID**

11

**CIM Information**

**Prefix:** PLAT ID: 0811

**User Response**

No action; information only.

- **810b050a-1e82ffff : Non-redundant:Insufficient Resources for [RedundancySetElementName] has deasserted. (Fan Zone 2)**

This message is for the use case when a Redundancy Set has transitioned from Non-redundant: Insufficient Resources.

May also be shown as 810b050a1e82ffff or 0x810b050a1e82ffff

**Severity**

Info

**Serviceable**

No

**Automatically notify support**

No

**Alert Category**

Critical - Fan Failure

**SNMP Trap ID**

11

**CIM Information**

**Prefix:** PLAT ID: 0811

**User Response**

No action; information only.

- **810b050a-1e83ffff : Non-redundant:Insufficient Resources for [RedundancySetElementName] has deasserted. (Fan Zone 3)**

This message is for the use case when a Redundancy Set has transitioned from Non-redundant: Insufficient Resources.

May also be shown as 810b050a1e83ffff or 0x810b050a1e83ffff

**Severity**

Info

**Serviceable**

No

**Automatically notify support**

No

**Alert Category**

Critical - Fan Failure

**SNMP Trap ID**

11

**CIM Information**

**Prefix:** PLAT ID: 0811

**User Response**

No action; information only.

- **810b050a-1e84ffff : Non-redundant:Insufficient Resources for [RedundancySetElementName] has deasserted. (Fan Zone 4)**

This message is for the use case when a Redundancy Set has transitioned from Non-redundant: Insufficient Resources.

May also be shown as 810b050a1e84ffff or 0x810b050a1e84ffff

**Severity**

Info

**Serviceable**

No

**Automatically notify support**

No

**Alert Category**

Critical - Fan Failure

**SNMP Trap ID**

11

**CIM Information**

**Prefix:** PLAT ID: 0811

**User Response**

No action; information only.

- **810b050c-2581ffff : Non-redundant:Insufficient Resources for [RedundancySetElementName] has deasserted. (Backup Memory)**

This message is for the use case when a Redundancy Set has transitioned from Non-redundant: Insufficient Resources.

May also be shown as 810b050c2581ffff or 0x810b050c2581ffff

**Severity**

Info

**Serviceable**

No

**Automatically notify support**

No

**Alert Category**

Critical - Memory

**SNMP Trap ID**

41

**CIM Information**

**Prefix:** PLAT ID: 0811

**User Response**



No action; information only.

- **816f0007-0301ffff : [ProcessorElementName] has Recovered from IERR. (CPU 1)**

This message is for the use case when an implementation has detected a Processor Recovered - IERR Condition.

May also be shown as 816f00070301ffff or 0x816f00070301ffff

**Severity**

Info

**Serviceable**

No

**Automatically notify support**

No

**Alert Category**

Critical - CPU

**SNMP Trap ID**

40

**CIM Information**

**Prefix: PLAT ID:** 0043

**User Response**

No action; information only.

- **816f0007-0302ffff : [ProcessorElementName] has Recovered from IERR. (CPU 2)**

This message is for the use case when an implementation has detected a Processor Recovered - IERR Condition.

May also be shown as 816f00070302ffff or 0x816f00070302ffff

**Severity**

Info

**Serviceable**

No

**Automatically notify support**

No

**Alert Category**

Critical - CPU

**SNMP Trap ID**

40

**CIM Information**

**Prefix: PLAT ID:** 0043

**User Response**

No action; information only.

- **816f0008-0a01ffff : [PowerSupplyElementName] has been removed from container [PhysicalPackageElementName]. (Power Supply 1)**

This message is for the use case when an implementation has detected a Power Supply has been removed.

May also be shown as 816f00080a01ffff or 0x816f00080a01ffff

**Severity**

Info

**Serviceable**

No

**Automatically notify support**

No

**Alert Category**

System - Other

**SNMP Trap ID****CIM Information**

Prefix: PLAT ID: 0085

**User Response**

No action; information only.

- **816f0008-0a02ffff : [PowerSupplyElementName] has been removed from container [PhysicalPackageElementName]. (Power Supply 2)**

This message is for the use case when an implementation has detected a Power Supply has been removed.

May also be shown as 816f00080a02ffff or 0x816f00080a02ffff

**Severity**

Info

**Serviceable**

No

**Automatically notify support**

No

**Alert Category**

System - Other

**SNMP Trap ID****CIM Information**

Prefix: PLAT ID: 0085

**User Response**

No action; information only.

- **816f0009-1301ffff : [PowerSupplyElementName] has been turned on. (Host Power)**

This message is for the use case when an implementation has detected a Power Unit that has been Enabled.

May also be shown as 816f00091301ffff or 0x816f00091301ffff

**Severity**

Info

**Serviceable**

No

**Automatically notify support**

No

**Alert Category**

System - Power On

**SNMP Trap ID**

**CIM Information****Prefix:** PLAT ID: 0107**User Response**

No action; information only.

- **816f000d-0400ffff : The Drive [StorageVolumeElementName] has been removed from unit [PhysicalPackageElementName]. (Drive 0)**

This message is for the use case when an implementation has detected a Drive has been Removed.

May also be shown as 816f000d0400ffff or 0x816f000d0400ffff

**Severity**

Info

**Serviceable**

Yes

**Automatically notify support**

No

**Alert Category**

System - Other

**SNMP Trap ID**

22

**CIM Information****Prefix:** PLAT ID: 0163**User Response**

1. Reseat hard disk drive n.(n = hard disk drive number). Wait 1 minute or more before reinstalling the drive.
  2. Replace the hard disk drive.
  3. Make sure that the disk firmware and RAID controller firmware are at the latest level.
  4. Replace backplane.
- **816f000d-0401ffff : The Drive [StorageVolumeElementName] has been removed from unit [PhysicalPackageElementName]. (Drive 1)**

This message is for the use case when an implementation has detected a Drive has been Removed.

May also be shown as 816f000d0401ffff or 0x816f000d0401ffff

**Severity**

Info

**Serviceable**

Yes

**Automatically notify support**

No

**Alert Category**

System - Other

**SNMP Trap ID**

22

**CIM Information****Prefix:** PLAT ID: 0163

### User Response

1. Reseat hard disk drive n.(n = hard disk drive number). Wait 1 minute or more before reinstalling the drive.
  2. Replace the hard disk drive.
  3. Make sure that the disk firmware and RAID controller firmware are at the latest level.
  4. Replace backplane.
- **816f000d-0402ffff : The Drive [StorageVolumeElementName] has been removed from unit [PhysicalPackageElementName]. (Drive 2)**

This message is for the use case when an implementation has detected a Drive has been Removed.

May also be shown as 816f000d0402ffff or 0x816f000d0402ffff

### Severity

Info

### Serviceable

Yes

### Automatically notify support

No

### Alert Category

System - Other

### SNMP Trap ID

22

### CIM Information

Prefix: PLAT ID: 0163

### User Response

1. Reseat hard disk drive n.(n = hard disk drive number). Wait 1 minute or more before reinstalling the drive.
  2. Replace the hard disk drive.
  3. Make sure that the disk firmware and RAID controller firmware are at the latest level.
  4. Replace backplane.
- **816f000d-0403ffff : The Drive [StorageVolumeElementName] has been removed from unit [PhysicalPackageElementName]. (Drive 3)**

This message is for the use case when an implementation has detected a Drive has been Removed.

May also be shown as 816f000d0403ffff or 0x816f000d0403ffff

### Severity

Info

### Serviceable

Yes

### Automatically notify support

No

### Alert Category

System - Other

### SNMP Trap ID

22

### CIM Information

**Prefix:** PLAT ID: 0163

**User Response**

1. Reseat hard disk drive n.(n = hard disk drive number). Wait 1 minute or more before reinstalling the drive.
  2. Replace the hard disk drive.
  3. Make sure that the disk firmware and RAID controller firmware are at the latest level.
  4. Replace backplane.
- **816f000d-0404ffff : The Drive [StorageVolumeElementName] has been removed from unit [PhysicalPackageElementName]. (Drive 4)**

This message is for the use case when an implementation has detected a Drive has been Removed.  
May also be shown as 816f000d0404ffff or 0x816f000d0404ffff

**Severity**

Info

**Serviceable**

Yes

**Automatically notify support**

No

**Alert Category**

System - Other

**SNMP Trap ID**

22

**CIM Information**

**Prefix:** PLAT ID: 0163

**User Response**

1. Reseat hard disk drive n.(n = hard disk drive number). Wait 1 minute or more before reinstalling the drive.
  2. Replace the hard disk drive.
  3. Make sure that the disk firmware and RAID controller firmware are at the latest level.
  4. Replace backplane.
- **816f000d-0405ffff : The Drive [StorageVolumeElementName] has been removed from unit [PhysicalPackageElementName]. (Drive 5)**

This message is for the use case when an implementation has detected a Drive has been Removed.  
May also be shown as 816f000d0405ffff or 0x816f000d0405ffff

**Severity**

Info

**Serviceable**

Yes

**Automatically notify support**

No

**Alert Category**

System - Other

**SNMP Trap ID**

22

**CIM Information**

Prefix: PLAT ID: 0163

**User Response**

1. Reseat hard disk drive n.(n = hard disk drive number). Wait 1 minute or more before reinstalling the drive.
  2. Replace the hard disk drive.
  3. Make sure that the disk firmware and RAID controller firmware are at the latest level.
  4. Replace backplane.
- **816f000d-0406ffff : The Drive [StorageVolumeElementName] has been removed from unit [PhysicalPackageElementName]. (Drive 6)**

This message is for the use case when an implementation has detected a Drive has been Removed.

May also be shown as 816f000d0406ffff or 0x816f000d0406ffff

**Severity**

Info

**Serviceable**

Yes

**Automatically notify support**

No

**Alert Category**

System - Other

**SNMP Trap ID**

22

**CIM Information**

Prefix: PLAT ID: 0163

**User Response**

1. Reseat hard disk drive n.(n = hard disk drive number). Wait 1 minute or more before reinstalling the drive.
  2. Replace the hard disk drive.
  3. Make sure that the disk firmware and RAID controller firmware are at the latest level.
  4. Replace backplane.
- **816f000d-0407ffff : The Drive [StorageVolumeElementName] has been removed from unit [PhysicalPackageElementName]. (Drive 7)**

This message is for the use case when an implementation has detected a Drive has been Removed.

May also be shown as 816f000d0407ffff or 0x816f000d0407ffff

**Severity**

Info

**Serviceable**

Yes

**Automatically notify support**

No

**Alert Category**

System - Other

**SNMP Trap ID**

**CIM Information**

Prefix: PLAT ID: 0163

**User Response**

1. Reseat hard disk drive n.(n = hard disk drive number). Wait 1 minute or more before reinstalling the drive.
  2. Replace the hard disk drive.
  3. Make sure that the disk firmware and RAID controller firmware are at the latest level.
  4. Replace backplane.
- **816f000d-0408ffff : The Drive [StorageVolumeElementName] has been removed from unit [PhysicalPackageElementName]. (Drive 8)**

This message is for the use case when an implementation has detected a Drive has been Removed.

May also be shown as 816f000d0408ffff or 0x816f000d0408ffff

**Severity**

Info

**Serviceable**

Yes

**Automatically notify support**

No

**Alert Category**

System - Other

**SNMP Trap ID**

22

**CIM Information**

Prefix: PLAT ID: 0163

**User Response**

1. Reseat hard disk drive n.(n = hard disk drive number). Wait 1 minute or more before reinstalling the drive.
  2. Replace the hard disk drive.
  3. Make sure that the disk firmware and RAID controller firmware are at the latest level.
  4. Replace backplane.
- **816f000d-0409ffff : The Drive [StorageVolumeElementName] has been removed from unit [PhysicalPackageElementName]. (Drive 9)**

This message is for the use case when an implementation has detected a Drive has been Removed.

May also be shown as 816f000d0409ffff or 0x816f000d0409ffff

**Severity**

Info

**Serviceable**

Yes

**Automatically notify support**

No

**Alert Category**

System - Other

**SNMP Trap ID**

22

**CIM Information****Prefix:** PLAT ID: 0163**User Response**

1. Reseat hard disk drive n.(n = hard disk drive number). Wait 1 minute or more before reinstalling the drive.
  2. Replace the hard disk drive.
  3. Make sure that the disk firmware and RAID controller firmware are at the latest level.
  4. Replace backplane.
- **816f000d-040affff : The Drive [StorageVolumeElementName] has been removed from unit [PhysicalPackageElementName]. (Drive 10)**

This message is for the use case when an implementation has detected a Drive has been Removed.

May also be shown as 816f000d040affff or 0x816f000d040affff

**Severity**

Info

**Serviceable**

Yes

**Automatically notify support**

No

**Alert Category**

System - Other

**SNMP Trap ID**

22

**CIM Information****Prefix:** PLAT ID: 0163**User Response**

1. Reseat hard disk drive n.(n = hard disk drive number). Wait 1 minute or more before reinstalling the drive.
  2. Replace the hard disk drive.
  3. Make sure that the disk firmware and RAID controller firmware are at the latest level.
  4. Replace backplane.
- **816f000d-040bffff : The Drive [StorageVolumeElementName] has been removed from unit [PhysicalPackageElementName]. (Drive 11)**

This message is for the use case when an implementation has detected a Drive has been Removed.

May also be shown as 816f000d040bffff or 0x816f000d040bffff

**Severity**

Info

**Serviceable**

Yes

**Automatically notify support**

No

**Alert Category**



System - Other

**SNMP Trap ID**

22

**CIM Information**

**Prefix:** PLAT ID: 0163

**User Response**

1. Reseat hard disk drive n.(n = hard disk drive number). Wait 1 minute or more before reinstalling the drive.
  2. Replace the hard disk drive.
  3. Make sure that the disk firmware and RAID controller firmware are at the latest level.
  4. Replace backplane.
- **816f000d-040cffff : The Drive [StorageVolumeElementName] has been removed from unit [PhysicalPackageElementName]. (Drive 12)**

This message is for the use case when an implementation has detected a Drive has been Removed.

May also be shown as 816f000d040cffff or 0x816f000d040cffff

**Severity**

Info

**Serviceable**

Yes

**Automatically notify support**

No

**Alert Category**

System - Other

**SNMP Trap ID**

22

**CIM Information**

**Prefix:** PLAT ID: 0163

**User Response**

1. Reseat hard disk drive n.(n = hard disk drive number). Wait 1 minute or more before reinstalling the drive.
  2. Replace the hard disk drive.
  3. Make sure that the disk firmware and RAID controller firmware are at the latest level.
  4. Replace backplane.
- **816f000d-040dffff : The Drive [StorageVolumeElementName] has been removed from unit [PhysicalPackageElementName]. (Drive 13)**

This message is for the use case when an implementation has detected a Drive has been Removed.

May also be shown as 816f000d040dffff or 0x816f000d040dffff

**Severity**

Info

**Serviceable**

Yes

**Automatically notify support**

No

**Alert Category**

System - Other

**SNMP Trap ID**

22

**CIM Information**

Prefix: PLAT ID: 0163

**User Response**

1. Reseat hard disk drive n.(n = hard disk drive number). Wait 1 minute or more before reinstalling the drive.
  2. Replace the hard disk drive.
  3. Make sure that the disk firmware and RAID controller firmware are at the latest level.
  4. Replace backplane.
- **816f000d-040effff : The Drive [StorageVolumeElementName] has been removed from unit [PhysicalPackageElementName]. (Drive 14)**

This message is for the use case when an implementation has detected a Drive has been Removed.

May also be shown as 816f000d040effff or 0x816f000d040effff

**Severity**

Info

**Serviceable**

Yes

**Automatically notify support**

No

**Alert Category**

System - Other

**SNMP Trap ID**

22

**CIM Information**

Prefix: PLAT ID: 0163

**User Response**

1. Reseat hard disk drive n.(n = hard disk drive number). Wait 1 minute or more before reinstalling the drive.
  2. Replace the hard disk drive.
  3. Make sure that the disk firmware and RAID controller firmware are at the latest level.
  4. Replace backplane.
- **816f000d-040fffff : The Drive [StorageVolumeElementName] has been removed from unit [PhysicalPackageElementName]. (Drive 15)**

This message is for the use case when an implementation has detected a Drive has been Removed.

May also be shown as 816f000d040fffff or 0x816f000d040fffff

**Severity**

Info

**Serviceable**

Yes

**Automatically notify support**

No

**Alert Category**

System - Other

**SNMP Trap ID**

22

**CIM Information**

**Prefix:** PLAT ID: 0163

**User Response**

1. Reseat hard disk drive n.(n = hard disk drive number). Wait 1 minute or more before reinstalling the drive.
  2. Replace the hard disk drive.
  3. Make sure that the disk firmware and RAID controller firmware are at the latest level.
  4. Replace backplane.
- **816f000d-0410ffff : The Drive [StorageVolumeElementName] has been removed from unit [PhysicalPackageElementName]. (Drive 16)**

This message is for the use case when an implementation has detected a Drive has been Removed.

May also be shown as 816f000d0410ffff or 0x816f000d0410ffff

**Severity**

Info

**Serviceable**

Yes

**Automatically notify support**

No

**Alert Category**

System - Other

**SNMP Trap ID**

22

**CIM Information**

**Prefix:** PLAT ID: 0163

**User Response**

1. Reseat hard disk drive n.(n = hard disk drive number). Wait 1 minute or more before reinstalling the drive.
  2. Replace the hard disk drive.
  3. Make sure that the disk firmware and RAID controller firmware are at the latest level.
  4. Replace backplane.
- **816f000d-0411ffff : The Drive [StorageVolumeElementName] has been removed from unit [PhysicalPackageElementName]. (Drive 17)**

This message is for the use case when an implementation has detected a Drive has been Removed.

May also be shown as 816f000d0411ffff or 0x816f000d0411ffff

**Severity**

Info

**Serviceable**

Yes

**Automatically notify support**

No

**Alert Category**

System - Other

**SNMP Trap ID**

22

**CIM Information**

Prefix: PLAT ID: 0163

**User Response**

1. Reseat hard disk drive n.(n = hard disk drive number). Wait 1 minute or more before reinstalling the drive.
  2. Replace the hard disk drive.
  3. Make sure that the disk firmware and RAID controller firmware are at the latest level.
  4. Replace backplane.
- **816f000d-0412ffff : The Drive [StorageVolumeElementName] has been removed from unit [PhysicalPackageElementName]. (Drive 18)**

This message is for the use case when an implementation has detected a Drive has been Removed.

May also be shown as 816f000d0412ffff or 0x816f000d0412ffff

**Severity**

Info

**Serviceable**

Yes

**Automatically notify support**

No

**Alert Category**

System - Other

**SNMP Trap ID**

22

**CIM Information**

Prefix: PLAT ID: 0163

**User Response**

1. Reseat hard disk drive n.(n = hard disk drive number). Wait 1 minute or more before reinstalling the drive.
  2. Replace the hard disk drive.
  3. Make sure that the disk firmware and RAID controller firmware are at the latest level.
  4. Replace backplane.
- **816f000d-0413ffff : The Drive [StorageVolumeElementName] has been removed from unit [PhysicalPackageElementName]. (Drive 19)**

This message is for the use case when an implementation has detected a Drive has been Removed.

May also be shown as 816f000d0413ffff or 0x816f000d0413ffff

**Severity**

Info

**Serviceable**

Yes

**Automatically notify support**

No

**Alert Category**

System - Other

**SNMP Trap ID**

22

**CIM Information**

**Prefix:** PLAT ID: 0163

**User Response**

1. Reseat hard disk drive n.(n = hard disk drive number). Wait 1 minute or more before reinstalling the drive.
  2. Replace the hard disk drive.
  3. Make sure that the disk firmware and RAID controller firmware are at the latest level.
  4. Replace backplane.
- **816f000d-0414ffff : The Drive [StorageVolumeElementName] has been removed from unit [PhysicalPackageElementName]. (Drive 20)**

This message is for the use case when an implementation has detected a Drive has been Removed.

May also be shown as 816f000d0414ffff or 0x816f000d0414ffff

**Severity**

Info

**Serviceable**

Yes

**Automatically notify support**

No

**Alert Category**

System - Other

**SNMP Trap ID**

22

**CIM Information**

**Prefix:** PLAT ID: 0163

**User Response**

1. Reseat hard disk drive n.(n = hard disk drive number). Wait 1 minute or more before reinstalling the drive.
  2. Replace the hard disk drive.
  3. Make sure that the disk firmware and RAID controller firmware are at the latest level.
  4. Replace backplane.
- **816f000d-0415ffff : The Drive [StorageVolumeElementName] has been removed from unit [PhysicalPackageElementName]. (Drive 21)**

This message is for the use case when an implementation has detected a Drive has been Removed.

May also be shown as 816f000d0415ffff or 0x816f000d0415ffff

**Severity**

Info

**Serviceable**

Yes

**Automatically notify support**

No

**Alert Category**

System - Other

**SNMP Trap ID**

22

**CIM Information**

Prefix: PLAT ID: 0163

**User Response**

1. Reseat hard disk drive n.(n = hard disk drive number). Wait 1 minute or more before reinstalling the drive.
  2. Replace the hard disk drive.
  3. Make sure that the disk firmware and RAID controller firmware are at the latest level.
  4. Replace backplane.
- **816f000d-0416ffff : The Drive [StorageVolumeElementName] has been removed from unit [PhysicalPackageElementName]. (Drive 22)**

This message is for the use case when an implementation has detected a Drive has been Removed.

May also be shown as 816f000d0416ffff or 0x816f000d0416ffff

**Severity**

Info

**Serviceable**

Yes

**Automatically notify support**

No

**Alert Category**

System - Other

**SNMP Trap ID**

22

**CIM Information**

Prefix: PLAT ID: 0163

**User Response**

1. Reseat hard disk drive n.(n = hard disk drive number). Wait 1 minute or more before reinstalling the drive.
  2. Replace the hard disk drive.
  3. Make sure that the disk firmware and RAID controller firmware are at the latest level.
  4. Replace backplane.
- **816f000d-0417ffff : The Drive [StorageVolumeElementName] has been removed from unit [PhysicalPackageElementName]. (Drive 23)**

This message is for the use case when an implementation has detected a Drive has been Removed.

May also be shown as 816f000d0417ffff or 0x816f000d0417ffff

**Severity**

Info

**Serviceable**

Yes

**Automatically notify support**

No

**Alert Category**

System - Other

**SNMP Trap ID**

22

**CIM Information**

**Prefix: PLAT ID:** 0163

**User Response**

1. Reseat hard disk drive n.(n = hard disk drive number). Wait 1 minute or more before reinstalling the drive.
  2. Replace the hard disk drive.
  3. Make sure that the disk firmware and RAID controller firmware are at the latest level.
  4. Replace backplane.
- **816f000d-0418ffff : The Drive [StorageVolumeElementName] has been removed from unit [PhysicalPackageElementName]. (Drive 24)**

This message is for the use case when an implementation has detected a Drive has been Removed.

May also be shown as 816f000d0418ffff or 0x816f000d0418ffff

**Severity**

Info

**Serviceable**

Yes

**Automatically notify support**

No

**Alert Category**

System - Other

**SNMP Trap ID**

22

**CIM Information**

**Prefix: PLAT ID:** 0163

**User Response**

1. Reseat hard disk drive n.(n = hard disk drive number). Wait 1 minute or more before reinstalling the drive.
  2. Replace the hard disk drive.
  3. Make sure that the disk firmware and RAID controller firmware are at the latest level.
  4. Replace backplane.
- **816f000d-0419ffff : The Drive [StorageVolumeElementName] has been removed from unit [PhysicalPackageElementName]. (Drive 25)**

This message is for the use case when an implementation has detected a Drive has been Removed.

May also be shown as 816f000d0419ffff or 0x816f000d0419ffff

**Severity**

Info

**Serviceable**

Yes

**Automatically notify support**

No

**Alert Category**

System - Other

**SNMP Trap ID**

22

**CIM Information****Prefix: PLAT ID:** 0163**User Response**

1. Reseat hard disk drive n.(n = hard disk drive number). Wait 1 minute or more before reinstalling the drive.
  2. Replace the hard disk drive.
  3. Make sure that the disk firmware and RAID controller firmware are at the latest level.
  4. Replace backplane.
- **816f000d-041affff : The Drive [StorageVolumeElementName] has been removed from unit [PhysicalPackageElementName]. (Drive 26)**

This message is for the use case when an implementation has detected a Drive has been Removed.

May also be shown as 816f000d041affff or 0x816f000d041affff

**Severity**

Info

**Serviceable**

Yes

**Automatically notify support**

No

**Alert Category**

System - Other

**SNMP Trap ID**

22

**CIM Information****Prefix: PLAT ID:** 0163**User Response**

1. Reseat hard disk drive n.(n = hard disk drive number). Wait 1 minute or more before reinstalling the drive.
  2. Replace the hard disk drive.
  3. Make sure that the disk firmware and RAID controller firmware are at the latest level.
  4. Replace backplane.
- **816f000d-041bffff : The Drive [StorageVolumeElementName] has been removed from unit [PhysicalPackageElementName]. (Drive 27)**

This message is for the use case when an implementation has detected a Drive has been Removed.

May also be shown as 816f000d041bffff or 0x816f000d041bffff



**Severity**

Info

**Serviceable**

Yes

**Automatically notify support**

No

**Alert Category**

System - Other

**SNMP Trap ID**

22

**CIM Information****Prefix: PLAT ID:** 0163**User Response**

1. Reseat hard disk drive n.(n = hard disk drive number). Wait 1 minute or more before reinstalling the drive.
  2. Replace the hard disk drive.
  3. Make sure that the disk firmware and RAID controller firmware are at the latest level.
  4. Replace backplane.
- **816f000d-041cffff : The Drive [StorageVolumeElementName] has been removed from unit [PhysicalPackageElementName]. (Drive 28)**

This message is for the use case when an implementation has detected a Drive has been Removed.

May also be shown as 816f000d041cffff or 0x816f000d041cffff

**Severity**

Info

**Serviceable**

Yes

**Automatically notify support**

No

**Alert Category**

System - Other

**SNMP Trap ID**

22

**CIM Information****Prefix: PLAT ID:** 0163**User Response**

1. Reseat hard disk drive n.(n = hard disk drive number). Wait 1 minute or more before reinstalling the drive.
  2. Replace the hard disk drive.
  3. Make sure that the disk firmware and RAID controller firmware are at the latest level.
  4. Replace backplane.
- **816f000d-041dffff : The Drive [StorageVolumeElementName] has been removed from unit [PhysicalPackageElementName]. (Drive 29)**

This message is for the use case when an implementation has detected a Drive has been Removed.

May also be shown as 816f000d041dffff or 0x816f000d041dffff

**Severity**

Info

**Serviceable**

Yes

**Automatically notify support**

No

**Alert Category**

System - Other

**SNMP Trap ID**

22

**CIM Information****Prefix: PLAT ID:** 0163**User Response**

1. Reseat hard disk drive n.(n = hard disk drive number). Wait 1 minute or more before reinstalling the drive.
  2. Replace the hard disk drive.
  3. Make sure that the disk firmware and RAID controller firmware are at the latest level.
  4. Replace backplane.
- **816f000d-041effff : The Drive [StorageVolumeElementName] has been removed from unit [PhysicalPackageElementName]. (Drive 30)**

This message is for the use case when an implementation has detected a Drive has been Removed.

May also be shown as 816f000d041effff or 0x816f000d041effff

**Severity**

Info

**Serviceable**

Yes

**Automatically notify support**

No

**Alert Category**

System - Other

**SNMP Trap ID**

22

**CIM Information****Prefix: PLAT ID:** 0163**User Response**

1. Reseat hard disk drive n.(n = hard disk drive number). Wait 1 minute or more before reinstalling the drive.
  2. Replace the hard disk drive.
  3. Make sure that the disk firmware and RAID controller firmware are at the latest level.
  4. Replace backplane.
- **816f000d-041fffff : The Drive [StorageVolumeElementName] has been removed from unit [PhysicalPackageElementName]. (Drive 31)**

This message is for the use case when an implementation has detected a Drive has been Removed.

May also be shown as 816f000d041fffff or 0x816f000d041fffff

**Severity**

Info

**Serviceable**

Yes

**Automatically notify support**

No

**Alert Category**

System - Other

**SNMP Trap ID**

22

**CIM Information****Prefix: PLAT ID:** 0163**User Response**

1. Reseat hard disk drive n.(n = hard disk drive number). Wait 1 minute or more before reinstalling the drive.
  2. Replace the hard disk drive.
  3. Make sure that the disk firmware and RAID controller firmware are at the latest level.
  4. Replace backplane.
- **816f000d-0420ffff : The Drive [StorageVolumeElementName] has been removed from unit [PhysicalPackageElementName]. (Ext Drive)**

This message is for the use case when an implementation has detected a Drive has been Removed.

May also be shown as 816f000d0420ffff or 0x816f000d0420ffff

**Severity**

Info

**Serviceable**

No

**Automatically notify support**

No

**Alert Category**

System - Other

**SNMP Trap ID**

22

**CIM Information****Prefix: PLAT ID:** 0163**User Response**

1. Reseat hard disk drive n.(n = hard disk drive number). Wait 1 minute or more before reinstalling the drive.
  2. Replace the hard disk drive.
  3. Make sure that the disk firmware and RAID controller firmware are at the latest level.
  4. Check the SAS cable.
- **816f000f-2201ffff : The System [ComputerSystemElementName] has detected a POST Error deassertion. (ABR Status)**

This message is for the use case when an implementation has detected that Post Error has deasserted.

May also be shown as 816f000f2201ffff or 0x816f000f2201ffff

**Severity**

Info

**Serviceable**

No

**Automatically notify support**

No

**Alert Category**

Critical - Other

**SNMP Trap ID**

50

**CIM Information****Prefix: PLAT ID:** 0185**User Response**

No action; information only. Firmware Error : Sys Boot Status : X8 PCI 1 Firm : X8 PCI 2 Firm : X8 PCI 6 Firm : X8 PCI 7 Firm :

- **816f0013-1701ffff : System [ComputerSystemElementName] has recovered from a diagnostic interrupt. (NMI State)**

This message is for the use case when an implementation has detected a recovery from a Front Panel NMI / Diagnostic Interrupt

May also be shown as 816f00131701ffff or 0x816f00131701ffff

**Severity**

Info

**Serviceable**

No

**Automatically notify support**

No

**Alert Category**

Critical - Other

**SNMP Trap ID**

50

**CIM Information****Prefix: PLAT ID:** 0223**User Response**

No action; information only.

- **816f0021-2201ffff : Fault condition removed on slot [PhysicalConnectorElementName] on system [ComputerSystemElementName]. (No Op ROM Space)**

This message is for the use case when an implementation has detected a Fault condition in a slot has been removed.

May also be shown as 816f00212201ffff or 0x816f00212201ffff

**Severity**

Info

**Serviceable**

No

**Automatically notify support**

No

**Alert Category**

Critical - Other

**SNMP Trap ID**

50

**CIM Information**

**Prefix:** PLAT ID: 0331

**User Response**

No action; information only.

- **816f0021-2582ffff : Fault condition removed on slot [PhysicalConnectorElementName] on system [ComputerSystemElementName]. (All PCI Error)**

This message is for the use case when an implementation has detected a Fault condition in a slot has been removed.

May also be shown as 816f00212582ffff or 0x816f00212582ffff

**Severity**

Info

**Serviceable**

No

**Automatically notify support**

No

**Alert Category**

Critical - Other

**SNMP Trap ID**

50

**CIM Information**

**Prefix:** PLAT ID: 0331

**User Response**

No action; information only. One of PCI Error :

- **816f0021-2c01ffff : Fault condition removed on slot [PhysicalConnectorElementName] on system [ComputerSystemElementName]. (ML2 Card Fault)**

This message is for the use case when an implementation has detected a Fault condition in a slot has been removed.

May also be shown as 816f00212c01ffff or 0x816f00212c01ffff

**Severity**

Info

**Serviceable**

No

**Automatically notify support**

No

**Alert Category**

Critical - Other

**SNMP Trap ID**

50

**CIM Information**

**Prefix:** PLAT ID: 0331

**User Response**

No action; information only.

- **816f0021-3001ffff : Fault condition removed on slot [PhysicalConnectorElementName] on system [ComputerSystemElementName]. (Internal RAID)**

This message is for the use case when an implementation has detected a Fault condition in a slot has been removed.

May also be shown as 816f00213001ffff or 0x816f00213001ffff

**Severity**

Info

**Serviceable**

No

**Automatically notify support**

No

**Alert Category**

Critical - Other

**SNMP Trap ID**

50

**CIM Information**

**Prefix: PLAT ID: 0331**

**User Response**

No action; information only. PCI 1 : PCI 2 : PCI 3 : PCI 4 : PCI 5 : PCI 6 : PCI 7 : PCI 8 :

- **816f0028-2101ffff : Sensor [SensorElementName] has returned to normal on management system [ComputerSystemElementName]. (TPM Cmd Failures)**

This message is for the use case when an implementation has detected a Sensor returned from degraded/unavailable/failure.

May also be shown as 816f00282101ffff or 0x816f00282101ffff

**Severity**

Info

**Serviceable**

No

**Automatically notify support**

No

**Alert Category**

Warning - Other

**SNMP Trap ID**

60

**CIM Information**

**Prefix: PLAT ID: 0399**

**User Response**

No action; information only.

- **816f0107-0301ffff : An Over-Temperature Condition has been removed on [ProcessorElementName]. (CPU 1)**

This message is for the use case when an implementation has detected a Over-Temperature Condition has been Removed for Processor.

May also be shown as 816f01070301ffff or 0x816f01070301ffff

**Severity**

Info

**Serviceable**

No

**Automatically notify support**

No

**Alert Category**

Critical - Temperature

**SNMP Trap ID**

0

**CIM Information****Prefix: PLAT ID: 0037****User Response**

No action; information only.

- **816f0107-0302ffff : An Over-Temperature Condition has been removed on [ProcessorElementName]. (CPU 2)**

This message is for the use case when an implementation has detected a Over-Temperature Condition has been Removed for Processor.

May also be shown as 816f01070302ffff or 0x816f01070302ffff

**Severity**

Info

**Serviceable**

No

**Automatically notify support**

No

**Alert Category**

Critical - Temperature

**SNMP Trap ID**

0

**CIM Information****Prefix: PLAT ID: 0037****User Response**

No action; information only.

- **816f0108-0a01ffff : [PowerSupplyElementName] has returned to OK status. (Power Supply 1)**

This message is for the use case when an implementation has detected a Power Supply return to normal operational status.

May also be shown as 816f01080a01ffff or 0x816f01080a01ffff

**Severity**

Info

**Serviceable**

No

**Automatically notify support**

No

**Alert Category**

Critical - Power

**SNMP Trap ID**

4

**CIM Information**

**Prefix:** PLAT ID: 0087

**User Response**

No action; information only.

- **816f0108-0a02ffff : [PowerSupplyElementName] has returned to OK status. (Power Supply 2)**

This message is for the use case when an implementation has detected a Power Supply return to normal operational status.

May also be shown as 816f01080a02ffff or 0x816f01080a02ffff

**Severity**

Info

**Serviceable**

No

**Automatically notify support**

No

**Alert Category**

Critical - Power

**SNMP Trap ID**

4

**CIM Information**

**Prefix:** PLAT ID: 0087

**User Response**

No action; information only.

- **816f010c-2001ffff : Uncorrectable error recovery detected for [PhysicalMemoryElementName] on Subsystem [MemoryElementName]. (DIMM 1)**

This message is for the use case when an implementation has detected a Memory uncorrectable error recovery.

May also be shown as 816f010c2001ffff or 0x816f010c2001ffff

**Severity**

Info

**Serviceable**

No

**Automatically notify support**

No

**Alert Category**

Critical - Memory

**SNMP Trap ID**

41

**CIM Information**

**Prefix:** PLAT ID: 0139

**User Response**

No action; information only.



- **816f010c-2002ffff : Uncorrectable error recovery detected for [PhysicalMemoryElementName] on Subsystem [MemoryElementName]. (DIMM 2)**

This message is for the use case when an implementation has detected a Memory uncorrectable error recovery.

May also be shown as 816f010c2002ffff or 0x816f010c2002ffff

**Severity**

Info

**Serviceable**

No

**Automatically notify support**

No

**Alert Category**

Critical - Memory

**SNMP Trap ID**

41

**CIM Information**

**Prefix: PLAT ID:** 0139

**User Response**

No action; information only.

- **816f010c-2003ffff : Uncorrectable error recovery detected for [PhysicalMemoryElementName] on Subsystem [MemoryElementName]. (DIMM 3)**

This message is for the use case when an implementation has detected a Memory uncorrectable error recovery.

May also be shown as 816f010c2003ffff or 0x816f010c2003ffff

**Severity**

Info

**Serviceable**

No

**Automatically notify support**

No

**Alert Category**

Critical - Memory

**SNMP Trap ID**

41

**CIM Information**

**Prefix: PLAT ID:** 0139

**User Response**

No action; information only.

- **816f010c-2004ffff : Uncorrectable error recovery detected for [PhysicalMemoryElementName] on Subsystem [MemoryElementName]. (DIMM 4)**

This message is for the use case when an implementation has detected a Memory uncorrectable error recovery.

May also be shown as 816f010c2004ffff or 0x816f010c2004ffff

**Severity**

Info

**Serviceable**

No

**Automatically notify support**

No

**Alert Category**

Critical - Memory

**SNMP Trap ID**

41

**CIM Information**

**Prefix: PLAT ID:** 0139

**User Response**

No action; information only.

- **816f010c-2005ffff : Uncorrectable error recovery detected for [PhysicalMemoryElementName] on Subsystem [MemoryElementName]. (DIMM 5)**

This message is for the use case when an implementation has detected a Memory uncorrectable error recovery.

May also be shown as 816f010c2005ffff or 0x816f010c2005ffff

**Severity**

Info

**Serviceable**

No

**Automatically notify support**

No

**Alert Category**

Critical - Memory

**SNMP Trap ID**

41

**CIM Information**

**Prefix: PLAT ID:** 0139

**User Response**

No action; information only.

- **816f010c-2006ffff : Uncorrectable error recovery detected for [PhysicalMemoryElementName] on Subsystem [MemoryElementName]. (DIMM 6)**

This message is for the use case when an implementation has detected a Memory uncorrectable error recovery.

May also be shown as 816f010c2006ffff or 0x816f010c2006ffff

**Severity**

Info

**Serviceable**

No

**Automatically notify support**

No

**Alert Category**

Critical - Memory

**SNMP Trap ID**

41

**CIM Information**

**Prefix:** PLAT ID: 0139

**User Response**

No action; information only.

- **816f010c-2007ffff : Uncorrectable error recovery detected for [PhysicalMemoryElementName] on Subsystem [MemoryElementName]. (DIMM 7)**

This message is for the use case when an implementation has detected a Memory uncorrectable error recovery.

May also be shown as 816f010c2007ffff or 0x816f010c2007ffff

**Severity**

Info

**Serviceable**

No

**Automatically notify support**

No

**Alert Category**

Critical - Memory

**SNMP Trap ID**

41

**CIM Information**

**Prefix:** PLAT ID: 0139

**User Response**

No action; information only.

- **816f010c-2008ffff : Uncorrectable error recovery detected for [PhysicalMemoryElementName] on Subsystem [MemoryElementName]. (DIMM 8)**

This message is for the use case when an implementation has detected a Memory uncorrectable error recovery.

May also be shown as 816f010c2008ffff or 0x816f010c2008ffff

**Severity**

Info

**Serviceable**

No

**Automatically notify support**

No

**Alert Category**

Critical - Memory

**SNMP Trap ID**

41

**CIM Information**

**Prefix:** PLAT ID: 0139

**User Response**

No action; information only.

- **816f010c-2009ffff : Uncorrectable error recovery detected for [PhysicalMemoryElementName] on Subsystem [MemoryElementName]. (DIMM 9)**

This message is for the use case when an implementation has detected a Memory uncorrectable error recovery.

May also be shown as 816f010c2009ffff or 0x816f010c2009ffff

**Severity**

Info

**Serviceable**

No

**Automatically notify support**

No

**Alert Category**

Critical - Memory

**SNMP Trap ID**

41

**CIM Information**

**Prefix: PLAT ID: 0139**

**User Response**

No action; information only.

- **816f010c-200affff : Uncorrectable error recovery detected for [PhysicalMemoryElementName] on Subsystem [MemoryElementName]. (DIMM 10)**

This message is for the use case when an implementation has detected a Memory uncorrectable error recovery.

May also be shown as 816f010c200affff or 0x816f010c200affff

**Severity**

Info

**Serviceable**

No

**Automatically notify support**

No

**Alert Category**

Critical - Memory

**SNMP Trap ID**

41

**CIM Information**

**Prefix: PLAT ID: 0139**

**User Response**

No action; information only.

- **816f010c-200bffff : Uncorrectable error recovery detected for [PhysicalMemoryElementName] on Subsystem [MemoryElementName]. (DIMM 11)**

This message is for the use case when an implementation has detected a Memory uncorrectable error recovery.

May also be shown as 816f010c200bffff or 0x816f010c200bffff

**Severity**

Info

**Serviceable**

No

**Automatically notify support**

No

**Alert Category**

Critical - Memory

**SNMP Trap ID**

41

**CIM Information****Prefix:** PLAT ID: 0139**User Response**

No action; information only.

- **816f010c-200cffff : Uncorrectable error recovery detected for [PhysicalMemoryElementName] on Subsystem [MemoryElementName]. (DIMM 12)**

This message is for the use case when an implementation has detected a Memory uncorrectable error recovery.

May also be shown as 816f010c200cffff or 0x816f010c200cffff

**Severity**

Info

**Serviceable**

No

**Automatically notify support**

No

**Alert Category**

Critical - Memory

**SNMP Trap ID**

41

**CIM Information****Prefix:** PLAT ID: 0139**User Response**

No action; information only.

- **816f010c-200dffff : Uncorrectable error recovery detected for [PhysicalMemoryElementName] on Subsystem [MemoryElementName]. (DIMM 13)**

This message is for the use case when an implementation has detected a Memory uncorrectable error recovery.

May also be shown as 816f010c200dffff or 0x816f010c200dffff

**Severity**

Info

**Serviceable**

No

**Automatically notify support**

No

**Alert Category**

Critical - Memory

**SNMP Trap ID**

41

**CIM Information**

Prefix: PLAT ID: 0139

**User Response**

No action; information only.

- **816f010c-200efff : Uncorrectable error recovery detected for [PhysicalMemoryElementName] on Subsystem [MemoryElementName]. (DIMM 14)**

This message is for the use case when an implementation has detected a Memory uncorrectable error recovery.

May also be shown as 816f010c200efff or 0x816f010c200efff

**Severity**

Info

**Serviceable**

No

**Automatically notify support**

No

**Alert Category**

Critical - Memory

**SNMP Trap ID**

41

**CIM Information**

Prefix: PLAT ID: 0139

**User Response**

No action; information only.

- **816f010c-200ffff : Uncorrectable error recovery detected for [PhysicalMemoryElementName] on Subsystem [MemoryElementName]. (DIMM 15)**

This message is for the use case when an implementation has detected a Memory uncorrectable error recovery.

May also be shown as 816f010c200ffff or 0x816f010c200ffff

**Severity**

Info

**Serviceable**

No

**Automatically notify support**

No

**Alert Category**

Critical - Memory

**SNMP Trap ID**

41

**CIM Information**

Prefix: PLAT ID: 0139

**User Response**

No action; information only.

- **816f010c-2010ffff : Uncorrectable error recovery detected for [PhysicalMemoryElementName] on Subsystem [MemoryElementName]. (DIMM 16)**

This message is for the use case when an implementation has detected a Memory uncorrectable error recovery.

May also be shown as 816f010c2010ffff or 0x816f010c2010ffff

**Severity**

Info

**Serviceable**

No

**Automatically notify support**

No

**Alert Category**

Critical - Memory

**SNMP Trap ID**

41

**CIM Information**

**Prefix: PLAT ID: 0139**

**User Response**

No action; information only.

- **816f010c-2011ffff : Uncorrectable error recovery detected for [PhysicalMemoryElementName] on Subsystem [MemoryElementName]. (DIMM 17)**

This message is for the use case when an implementation has detected a Memory uncorrectable error recovery.

May also be shown as 816f010c2011ffff or 0x816f010c2011ffff

**Severity**

Info

**Serviceable**

No

**Automatically notify support**

No

**Alert Category**

Critical - Memory

**SNMP Trap ID**

41

**CIM Information**

**Prefix: PLAT ID: 0139**

**User Response**

No action; information only.

- **816f010c-2012ffff : Uncorrectable error recovery detected for [PhysicalMemoryElementName] on Subsystem [MemoryElementName]. (DIMM 18)**

This message is for the use case when an implementation has detected a Memory uncorrectable error recovery.

May also be shown as 816f010c2012ffff or 0x816f010c2012ffff

**Severity**

Info

**Serviceable**

No

**Automatically notify support**

No

**Alert Category**

Critical - Memory

**SNMP Trap ID**

41

**CIM Information****Prefix: PLAT ID:** 0139**User Response**

No action; information only.

- **816f010c-2013ffff : Uncorrectable error recovery detected for [PhysicalMemoryElementName] on Subsystem [MemoryElementName]. (DIMM 19)**

This message is for the use case when an implementation has detected a Memory uncorrectable error recovery.

May also be shown as 816f010c2013ffff or 0x816f010c2013ffff

**Severity**

Info

**Serviceable**

No

**Automatically notify support**

No

**Alert Category**

Critical - Memory

**SNMP Trap ID**

41

**CIM Information****Prefix: PLAT ID:** 0139**User Response**

No action; information only.

- **816f010c-2014ffff : Uncorrectable error recovery detected for [PhysicalMemoryElementName] on Subsystem [MemoryElementName]. (DIMM 20)**

This message is for the use case when an implementation has detected a Memory uncorrectable error recovery.

May also be shown as 816f010c2014ffff or 0x816f010c2014ffff

**Severity**

Info

**Serviceable**

No

**Automatically notify support**

No



**Alert Category**

Critical - Memory

**SNMP Trap ID**

41

**CIM Information**

**Prefix:** PLAT ID: 0139

**User Response**

No action; information only.

- **816f010c-2015ffff : Uncorrectable error recovery detected for [PhysicalMemoryElementName] on Subsystem [MemoryElementName]. (DIMM 21)**

This message is for the use case when an implementation has detected a Memory uncorrectable error recovery.

May also be shown as 816f010c2015ffff or 0x816f010c2015ffff

**Severity**

Info

**Serviceable**

No

**Automatically notify support**

No

**Alert Category**

Critical - Memory

**SNMP Trap ID**

41

**CIM Information**

**Prefix:** PLAT ID: 0139

**User Response**

No action; information only.

- **816f010c-2016ffff : Uncorrectable error recovery detected for [PhysicalMemoryElementName] on Subsystem [MemoryElementName]. (DIMM 22)**

This message is for the use case when an implementation has detected a Memory uncorrectable error recovery.

May also be shown as 816f010c2016ffff or 0x816f010c2016ffff

**Severity**

Info

**Serviceable**

No

**Automatically notify support**

No

**Alert Category**

Critical - Memory

**SNMP Trap ID**

41

**CIM Information**

**Prefix:** PLAT ID: 0139

**User Response**

No action; information only.

- **816f010c-2017ffff : Uncorrectable error recovery detected for [PhysicalMemoryElementName] on Subsystem [MemoryElementName]. (DIMM 23)**

This message is for the use case when an implementation has detected a Memory uncorrectable error recovery.

May also be shown as 816f010c2017ffff or 0x816f010c2017ffff

**Severity**

Info

**Serviceable**

No

**Automatically notify support**

No

**Alert Category**

Critical - Memory

**SNMP Trap ID**

41

**CIM Information**

Prefix: PLAT ID: 0139

**User Response**

No action; information only.

- **816f010c-2018ffff : Uncorrectable error recovery detected for [PhysicalMemoryElementName] on Subsystem [MemoryElementName]. (DIMM 24)**

This message is for the use case when an implementation has detected a Memory uncorrectable error recovery.

May also be shown as 816f010c2018ffff or 0x816f010c2018ffff

**Severity**

Info

**Serviceable**

No

**Automatically notify support**

No

**Alert Category**

Critical - Memory

**SNMP Trap ID**

41

**CIM Information**

Prefix: PLAT ID: 0139

**User Response**

No action; information only.

- **816f010c-2581ffff : Uncorrectable error recovery detected for [PhysicalMemoryElementName] on Subsystem [MemoryElementName]. (All DIMMS)**

This message is for the use case when an implementation has detected a Memory uncorrectable error recovery.

May also be shown as 816f010c2581ffff or 0x816f010c2581ffff

**Severity**

Info

**Serviceable**

No

**Automatically notify support**

No

**Alert Category**

Critical - Memory

**SNMP Trap ID**

41

**CIM Information****Prefix:** PLAT ID: 0139**User Response**

No action; information only. One of the DIMMs :

- **816f010d-0400ffff : The Drive [StorageVolumeElementName] has been enabled. (Drive 0)**

This message is for the use case when an implementation has detected a Drive was Enabled.

May also be shown as 816f010d0400ffff or 0x816f010d0400ffff

**Severity**

Info

**Serviceable**

No

**Automatically notify support**

No

**Alert Category**

Critical - Hard Disk drive

**SNMP Trap ID**

5

**CIM Information****Prefix:** PLAT ID: 0167**User Response**

No action; information only.

- **816f010d-0401ffff : The Drive [StorageVolumeElementName] has been enabled. (Drive 1)**

This message is for the use case when an implementation has detected a Drive was Enabled.

May also be shown as 816f010d0401ffff or 0x816f010d0401ffff

**Severity**

Info

**Serviceable**

No

**Automatically notify support**

No

**Alert Category**

Critical - Hard Disk drive

**SNMP Trap ID**

5

**CIM Information**

Prefix: PLAT ID: 0167

**User Response**

No action; information only.

- **816f010d-0402ffff : The Drive [StorageVolumeElementName] has been enabled. (Drive 2)**

This message is for the use case when an implementation has detected a Drive was Enabled.

May also be shown as 816f010d0402ffff or 0x816f010d0402ffff

**Severity**

Info

**Serviceable**

No

**Automatically notify support**

No

**Alert Category**

Critical - Hard Disk drive

**SNMP Trap ID**

5

**CIM Information**

Prefix: PLAT ID: 0167

**User Response**

No action; information only.

- **816f010d-0403ffff : The Drive [StorageVolumeElementName] has been enabled. (Drive 3)**

This message is for the use case when an implementation has detected a Drive was Enabled.

May also be shown as 816f010d0403ffff or 0x816f010d0403ffff

**Severity**

Info

**Serviceable**

No

**Automatically notify support**

No

**Alert Category**

Critical - Hard Disk drive

**SNMP Trap ID**

5

**CIM Information**

Prefix: PLAT ID: 0167

**User Response**

No action; information only.

- **816f010d-0404ffff : The Drive [StorageVolumeElementName] has been enabled. (Drive 4)**

This message is for the use case when an implementation has detected a Drive was Enabled.

May also be shown as 816f010d0404ffff or 0x816f010d0404ffff

**Severity**

Info

**Serviceable**

No

**Automatically notify support**

No

**Alert Category**

Critical - Hard Disk drive

**SNMP Trap ID**

5

**CIM Information**

**Prefix:** PLAT ID: 0167

**User Response**

No action; information only.

- **816f010d-0405ffff : The Drive [StorageVolumeElementName] has been enabled. (Drive 5)**

This message is for the use case when an implementation has detected a Drive was Enabled.

May also be shown as 816f010d0405ffff or 0x816f010d0405ffff

**Severity**

Info

**Serviceable**

No

**Automatically notify support**

No

**Alert Category**

Critical - Hard Disk drive

**SNMP Trap ID**

5

**CIM Information**

**Prefix:** PLAT ID: 0167

**User Response**

No action; information only.

- **816f010d-0406ffff : The Drive [StorageVolumeElementName] has been enabled. (Drive 6)**

This message is for the use case when an implementation has detected a Drive was Enabled.

May also be shown as 816f010d0406ffff or 0x816f010d0406ffff

**Severity**

Info

**Serviceable**

No

**Automatically notify support**

No

**Alert Category**

Critical - Hard Disk drive

**SNMP Trap ID**

5

**CIM Information**

**Prefix:** PLAT ID: 0167

**User Response**

No action; information only.

- **816f010d-0407ffff : The Drive [StorageVolumeElementName] has been enabled. (Drive 7)**

This message is for the use case when an implementation has detected a Drive was Enabled.

May also be shown as 816f010d0407ffff or 0x816f010d0407ffff

**Severity**

Info

**Serviceable**

No

**Automatically notify support**

No

**Alert Category**

Critical - Hard Disk drive

**SNMP Trap ID**

5

**CIM Information**

Prefix: PLAT ID: 0167

**User Response**

No action; information only.

- **816f010d-0408ffff : The Drive [StorageVolumeElementName] has been enabled. (Drive 8)**

This message is for the use case when an implementation has detected a Drive was Enabled.

May also be shown as 816f010d0408ffff or 0x816f010d0408ffff

**Severity**

Info

**Serviceable**

No

**Automatically notify support**

No

**Alert Category**

Critical - Hard Disk drive

**SNMP Trap ID**

5

**CIM Information**

Prefix: PLAT ID: 0167

**User Response**

No action; information only.

- **816f010d-0409ffff : The Drive [StorageVolumeElementName] has been enabled. (Drive 9)**

This message is for the use case when an implementation has detected a Drive was Enabled.

May also be shown as 816f010d0409ffff or 0x816f010d0409ffff

**Severity**

Info

**Serviceable**

No

**Automatically notify support**

No

**Alert Category**

Critical - Hard Disk drive

**SNMP Trap ID**

5

**CIM Information**

**Prefix:** PLAT ID: 0167

**User Response**

No action; information only.

- **816f010d-040affff : The Drive [StorageVolumeElementName] has been enabled. (Drive 10)**

This message is for the use case when an implementation has detected a Drive was Enabled.

May also be shown as 816f010d040affff or 0x816f010d040affff

**Severity**

Info

**Serviceable**

No

**Automatically notify support**

No

**Alert Category**

Critical - Hard Disk drive

**SNMP Trap ID**

5

**CIM Information**

**Prefix:** PLAT ID: 0167

**User Response**

No action; information only.

- **816f010d-040bffff : The Drive [StorageVolumeElementName] has been enabled. (Drive 11)**

This message is for the use case when an implementation has detected a Drive was Enabled.

May also be shown as 816f010d040bffff or 0x816f010d040bffff

**Severity**

Info

**Serviceable**

No

**Automatically notify support**

No

**Alert Category**

Critical - Hard Disk drive

**SNMP Trap ID**

5

**CIM Information**

**Prefix:** PLAT ID: 0167

**User Response**

No action; information only.

- **816f010d-040cffff : The Drive [StorageVolumeElementName] has been enabled. (Drive 12)**

This message is for the use case when an implementation has detected a Drive was Enabled.

May also be shown as 816f010d040cffff or 0x816f010d040cffff

**Severity**

Info

**Serviceable**

No

**Automatically notify support**

No

**Alert Category**

Critical - Hard Disk drive

**SNMP Trap ID**

5

**CIM Information**

Prefix: PLAT ID: 0167

**User Response**

No action; information only.

- **816f010d-040dffff : The Drive [StorageVolumeElementName] has been enabled. (Drive 13)**

This message is for the use case when an implementation has detected a Drive was Enabled.

May also be shown as 816f010d040dffff or 0x816f010d040dffff

**Severity**

Info

**Serviceable**

No

**Automatically notify support**

No

**Alert Category**

Critical - Hard Disk drive

**SNMP Trap ID**

5

**CIM Information**

Prefix: PLAT ID: 0167

**User Response**

No action; information only.

- **816f010d-040effff : The Drive [StorageVolumeElementName] has been enabled. (Drive 14)**

This message is for the use case when an implementation has detected a Drive was Enabled.

May also be shown as 816f010d040effff or 0x816f010d040effff

**Severity**

Info

**Serviceable**

No

**Automatically notify support**



No

**Alert Category**

Critical - Hard Disk drive

**SNMP Trap ID**

5

**CIM Information**

**Prefix:** PLAT ID: 0167

**User Response**

No action; information only.

- **816f010d-040ffff : The Drive [StorageVolumeElementName] has been enabled. (Drive 15)**

This message is for the use case when an implementation has detected a Drive was Enabled.

May also be shown as 816f010d040ffff or 0x816f010d040ffff

**Severity**

Info

**Serviceable**

No

**Automatically notify support**

No

**Alert Category**

Critical - Hard Disk drive

**SNMP Trap ID**

5

**CIM Information**

**Prefix:** PLAT ID: 0167

**User Response**

No action; information only.

- **816f010d-0410ffff : The Drive [StorageVolumeElementName] has been enabled. (Drive 16)**

This message is for the use case when an implementation has detected a Drive was Enabled.

May also be shown as 816f010d0410ffff or 0x816f010d0410ffff

**Severity**

Info

**Serviceable**

No

**Automatically notify support**

No

**Alert Category**

Critical - Hard Disk drive

**SNMP Trap ID**

5

**CIM Information**

**Prefix:** PLAT ID: 0167

**User Response**

No action; information only.

- **816f010d-0411ffff : The Drive [StorageVolumeElementName] has been enabled. (Drive 17)**

This message is for the use case when an implementation has detected a Drive was Enabled.

May also be shown as 816f010d0411ffff or 0x816f010d0411ffff

**Severity**

Info

**Serviceable**

No

**Automatically notify support**

No

**Alert Category**

Critical - Hard Disk drive

**SNMP Trap ID**

5

**CIM Information**

Prefix: PLAT ID: 0167

**User Response**

No action; information only.

- **816f010d-0412ffff : The Drive [StorageVolumeElementName] has been enabled. (Drive 18)**

This message is for the use case when an implementation has detected a Drive was Enabled.

May also be shown as 816f010d0412ffff or 0x816f010d0412ffff

**Severity**

Info

**Serviceable**

No

**Automatically notify support**

No

**Alert Category**

Critical - Hard Disk drive

**SNMP Trap ID**

5

**CIM Information**

Prefix: PLAT ID: 0167

**User Response**

No action; information only.

- **816f010d-0413ffff : The Drive [StorageVolumeElementName] has been enabled. (Drive 19)**

This message is for the use case when an implementation has detected a Drive was Enabled.

May also be shown as 816f010d0413ffff or 0x816f010d0413ffff

**Severity**

Info

**Serviceable**

No

**Automatically notify support**

No

**Alert Category**

Critical - Hard Disk drive

**SNMP Trap ID**

5

**CIM Information**

**Prefix:** PLAT ID: 0167

**User Response**

No action; information only.

- **816f010d-0414ffff : The Drive [StorageVolumeElementName] has been enabled. (Drive 20)**

This message is for the use case when an implementation has detected a Drive was Enabled.

May also be shown as 816f010d0414ffff or 0x816f010d0414ffff

**Severity**

Info

**Serviceable**

No

**Automatically notify support**

No

**Alert Category**

Critical - Hard Disk drive

**SNMP Trap ID**

5

**CIM Information**

**Prefix:** PLAT ID: 0167

**User Response**

No action; information only.

- **816f010d-0415ffff : The Drive [StorageVolumeElementName] has been enabled. (Drive 21)**

This message is for the use case when an implementation has detected a Drive was Enabled.

May also be shown as 816f010d0415ffff or 0x816f010d0415ffff

**Severity**

Info

**Serviceable**

No

**Automatically notify support**

No

**Alert Category**

Critical - Hard Disk drive

**SNMP Trap ID**

5

**CIM Information**

**Prefix:** PLAT ID: 0167

**User Response**

No action; information only.

- **816f010d-0416ffff : The Drive [StorageVolumeElementName] has been enabled. (Drive 22)**

This message is for the use case when an implementation has detected a Drive was Enabled.

May also be shown as 816f010d0416ffff or 0x816f010d0416ffff

**Severity**

Info

**Serviceable**

No

**Automatically notify support**

No

**Alert Category**

Critical - Hard Disk drive

**SNMP Trap ID**

5

**CIM Information**

**Prefix: PLAT ID:** 0167

**User Response**

No action; information only.

- **816f010d-0417ffff : The Drive [StorageVolumeElementName] has been enabled. (Drive 23)**

This message is for the use case when an implementation has detected a Drive was Enabled.

May also be shown as 816f010d0417ffff or 0x816f010d0417ffff

**Severity**

Info

**Serviceable**

No

**Automatically notify support**

No

**Alert Category**

Critical - Hard Disk drive

**SNMP Trap ID**

5

**CIM Information**

**Prefix: PLAT ID:** 0167

**User Response**

No action; information only.

- **816f010d-0418ffff : The Drive [StorageVolumeElementName] has been enabled. (Drive 24)**

This message is for the use case when an implementation has detected a Drive was Enabled.

May also be shown as 816f010d0418ffff or 0x816f010d0418ffff

**Severity**

Info

**Serviceable**

No

**Automatically notify support**

No

**Alert Category**

Critical - Hard Disk drive

**SNMP Trap ID**

5

**CIM Information****Prefix:** PLAT ID: 0167**User Response**

No action; information only.

- **816f010d-0419ffff : The Drive [StorageVolumeElementName] has been enabled. (Drive 25)**

This message is for the use case when an implementation has detected a Drive was Enabled.

May also be shown as 816f010d0419ffff or 0x816f010d0419ffff

**Severity**

Info

**Serviceable**

No

**Automatically notify support**

No

**Alert Category**

Critical - Hard Disk drive

**SNMP Trap ID**

5

**CIM Information****Prefix:** PLAT ID: 0167**User Response**

No action; information only.

- **816f010d-041affff : The Drive [StorageVolumeElementName] has been enabled. (Drive 26)**

This message is for the use case when an implementation has detected a Drive was Enabled.

May also be shown as 816f010d041affff or 0x816f010d041affff

**Severity**

Info

**Serviceable**

No

**Automatically notify support**

No

**Alert Category**

Critical - Hard Disk drive

**SNMP Trap ID**

5

**CIM Information****Prefix:** PLAT ID: 0167**User Response**

No action; information only.

- **816f010d-041bffff : The Drive [StorageVolumeElementName] has been enabled. (Drive 27)**

This message is for the use case when an implementation has detected a Drive was Enabled.

May also be shown as 816f010d041bffff or 0x816f010d041bffff

**Severity**

Info

**Serviceable**

No

**Automatically notify support**

No

**Alert Category**

Critical - Hard Disk drive

**SNMP Trap ID**

5

**CIM Information****Prefix: PLAT ID:** 0167**User Response**

No action; information only.

- **816f010d-041cffff : The Drive [StorageVolumeElementName] has been enabled. (Drive 28)**

This message is for the use case when an implementation has detected a Drive was Enabled.

May also be shown as 816f010d041cffff or 0x816f010d041cffff

**Severity**

Info

**Serviceable**

No

**Automatically notify support**

No

**Alert Category**

Critical - Hard Disk drive

**SNMP Trap ID**

5

**CIM Information****Prefix: PLAT ID:** 0167**User Response**

No action; information only.

- **816f010d-041dffff : The Drive [StorageVolumeElementName] has been enabled. (Drive 29)**

This message is for the use case when an implementation has detected a Drive was Enabled.

May also be shown as 816f010d041dffff or 0x816f010d041dffff

**Severity**

Info

**Serviceable**

No

**Automatically notify support**

No

**Alert Category**

Critical - Hard Disk drive

**SNMP Trap ID**

5

**CIM Information**

Prefix: PLAT ID: 0167

**User Response**

No action; information only.

- **816f010d-041effff : The Drive [StorageVolumeElementName] has been enabled. (Drive 30)**

This message is for the use case when an implementation has detected a Drive was Enabled.

May also be shown as 816f010d041effff or 0x816f010d041effff

**Severity**

Info

**Serviceable**

No

**Automatically notify support**

No

**Alert Category**

Critical - Hard Disk drive

**SNMP Trap ID**

5

**CIM Information**

Prefix: PLAT ID: 0167

**User Response**

No action; information only.

- **816f010d-041fffff : The Drive [StorageVolumeElementName] has been enabled. (Drive 31)**

This message is for the use case when an implementation has detected a Drive was Enabled.

May also be shown as 816f010d041fffff or 0x816f010d041fffff

**Severity**

Info

**Serviceable**

No

**Automatically notify support**

No

**Alert Category**

Critical - Hard Disk drive

**SNMP Trap ID**

5

**CIM Information**

Prefix: PLAT ID: 0167

**User Response**

No action; information only.

- **816f010d-0420ffff : The Drive [StorageVolumeElementName] has been enabled. (Ext Drive)**

This message is for the use case when an implementation has detected a Drive was Enabled.

May also be shown as 816f010d0420ffff or 0x816f010d0420ffff

**Severity**

Info

**Serviceable**

No

**Automatically notify support**

No

**Alert Category**

Critical - Hard Disk drive

**SNMP Trap ID**

5

**CIM Information**

Prefix: PLAT ID: 0167

**User Response**

No action; information only.

- **816f010f-2201ffff : The System [ComputerSystemElementName] has recovered from a firmware hang. (Firmware Error)**

This message is for the use case when an implementation has recovered from a System Firmware Hang.

May also be shown as 816f010f2201ffff or 0x816f010f2201ffff

**Severity**

Info

**Serviceable**

No

**Automatically notify support**

No

**Alert Category**

Critical - Other

**SNMP Trap ID**

50

**CIM Information**

Prefix: PLAT ID: 0187

**User Response**

No action; information only.

- **816f0113-0301ffff : System [ComputerSystemElementName] has recovered from a bus timeout. (CPU 1 PEI)**

This message is for the use case when an implementation has detected that a system has recovered from a Bus Timeout.

May also be shown as 816f01130301ffff or 0x816f01130301ffff

**Severity**

Info

**Serviceable**

No

**Automatically notify support**

No

**Alert Category**

Critical - Other

**SNMP Trap ID**



**CIM Information****Prefix:** PLAT ID: 0225**User Response**

1. (Trained technician only) Replace microprocessor n (see Removing a microprocessor and heat sink and Replacing a microprocessor and heat sink).
  2. If the problem persists and there is no other CPU with the same error indication, replace the system board.
  3. (Trained technician only) Replace the system board (see Removing the system board and Replacing the system board). (n = microprocessor number)
- **816f0113-0302ffff : System [ComputerSystemElementName] has recovered from a bus timeout. (CPU 2 PECI)**

This message is for the use case when an implementation has detected that a system has recovered from a Bus Timeout.

May also be shown as 816f01130302ffff or 0x816f01130302ffff

**Severity**

Info

**Serviceable**

No

**Automatically notify support**

No

**Alert Category**

Critical - Other

**SNMP Trap ID**

50

**CIM Information****Prefix:** PLAT ID: 0225**User Response**

1. (Trained technician only) Replace microprocessor n (see Removing a microprocessor and heat sink and Replacing a microprocessor and heat sink).
  2. If the problem persists and there is no other CPU with the same error indication, replace the system board.
  3. (Trained technician only) Replace the system board (see Removing the system board and Replacing the system board). (n = microprocessor number)
- **816f011b-0701ffff : The connector [PhysicalConnectorElementName] configuration error has been repaired. (Front USB)**

This message is for the use case when an implementation has detected an Interconnect Configuration was Repaired.

May also be shown as 816f011b0701ffff or 0x816f011b0701ffff

**Severity**

Info

**Serviceable**

No

**Automatically notify support**

No

**Alert Category**

Critical - Other

**SNMP Trap ID**

50

**CIM Information**

Prefix: PLAT ID: 0267

**User Response**

No action; information only. Front Video :

- **816f011b-0c01ffff : The connector [PhysicalConnectorElementName] configuration error has been repaired. (FP LCD Cable)**

This message is for the use case when an implementation has detected an Interconnect Configuration was Repaired.

May also be shown as 816f011b0c01ffff or 0x816f011b0c01ffff

**Severity**

Info

**Serviceable**

No

**Automatically notify support**

No

**Alert Category**

Critical - Other

**SNMP Trap ID**

50

**CIM Information**

Prefix: PLAT ID: 0267

**User Response**

No action; information only.

- **816f011b-2586ffff : The connector [PhysicalConnectorElementName] configuration error has been repaired. (nvDIMM Cable)**

This message is for the use case when an implementation has detected an Interconnect Configuration was Repaired.

May also be shown as 816f011b2586ffff or 0x816f011b2586ffff

**Severity**

Info

**Serviceable**

No

**Automatically notify support**

No

**Alert Category**

Critical - Other

**SNMP Trap ID**

50

**CIM Information**

**Prefix: PLAT ID:** 0267

**User Response**

No action; information only.

- **816f0125-0c01ffff : [ManagedElementName] detected as present. (Front Panel)**

This message is for the use case when an implementation has detected a Managed Element is now Present.

May also be shown as 816f01250c01ffff or 0x816f01250c01ffff

**Severity**

Info

**Serviceable**

No

**Automatically notify support**

No

**Alert Category**

System - Other

**SNMP Trap ID**

**CIM Information**

**Prefix: PLAT ID:** 0390

**User Response**

No action; information only.

- **816f0125-1001ffff : [ManagedElementName] detected as present. (PCI Riser 1)**

This message is for the use case when an implementation has detected a Managed Element is now Present.

May also be shown as 816f01251001ffff or 0x816f01251001ffff

**Severity**

Info

**Serviceable**

No

**Automatically notify support**

No

**Alert Category**

System - Other

**SNMP Trap ID**

**CIM Information**

**Prefix: PLAT ID:** 0390

**User Response**

No action; information only.

- **816f0125-1002ffff : [ManagedElementName] detected as present. (PCI Riser 2)**

This message is for the use case when an implementation has detected a Managed Element is now Present.

May also be shown as 816f01251002ffff or 0x816f01251002ffff

**Severity**

Info

**Serviceable**

No

**Automatically notify support**

No

**Alert Category**

System - Other

**SNMP Trap ID****CIM Information**

Prefix: PLAT ID: 0390

**User Response**

No action; information only.

- **816f0125-100bffff : [ManagedElementName] detected as present. (PDB Card)**

This message is for the use case when an implementation has detected a Managed Element is now Present.

May also be shown as 816f0125100bffff or 0x816f0125100bffff

**Severity**

Info

**Serviceable**

No

**Automatically notify support**

No

**Alert Category**

System - Other

**SNMP Trap ID****CIM Information**

Prefix: PLAT ID: 0390

**User Response**

No action; information only.

- **816f0125-2c01ffff : [ManagedElementName] detected as present. (ML2 Card)**

This message is for the use case when an implementation has detected a Managed Element is now Present.

May also be shown as 816f01252c01ffff or 0x816f01252c01ffff

**Severity**

Info

**Serviceable**

No

**Automatically notify support**

No

**Alert Category**

System - Other

## SNMP Trap ID

### CIM Information

Prefix: PLAT ID: 0390

### User Response

No action; information only.

- **816f0207-0301ffff : [ProcessorElementName] has Recovered from FRB1/BIST condition. (CPU 1)**

This message is for the use case when an implementation has detected a Processor Recovered - FRB1/BIST condition.

May also be shown as 816f02070301ffff or 0x816f02070301ffff

### Severity

Info

### Serviceable

No

### Automatically notify support

No

### Alert Category

Critical - CPU

### SNMP Trap ID

40

### CIM Information

Prefix: PLAT ID: 0045

### User Response

No action; information only.

- **816f0207-0302ffff : [ProcessorElementName] has Recovered from FRB1/BIST condition. (CPU 2)**

This message is for the use case when an implementation has detected a Processor Recovered - FRB1/BIST condition.

May also be shown as 816f02070302ffff or 0x816f02070302ffff

### Severity

Info

### Serviceable

No

### Automatically notify support

No

### Alert Category

Critical - CPU

### SNMP Trap ID

40

### CIM Information

Prefix: PLAT ID: 0045

### User Response

No action; information only.

- **816f0207-2584ffff : [ProcessorElementName] has Recovered from FRB1/BIST condition. (All CPUs)**

This message is for the use case when an implementation has detected a Processor Recovered - FRB1/ BIST condition.

May also be shown as 816f02072584ffff or 0x816f02072584ffff

**Severity**

Info

**Serviceable**

No

**Automatically notify support**

No

**Alert Category**

Critical - CPU

**SNMP Trap ID**

40

**CIM Information**

Prefix: PLAT ID: 0045

**User Response**

No action; information only. One of the CPUs :

- **816f020d-0400ffff : Failure no longer Predicted on drive [StorageVolumeElementName] for array [ComputerSystemElementName]. (Drive 0)**

This message is for the use case when an implementation has detected an Array Failure is no longer Predicted.

May also be shown as 816f020d0400ffff or 0x816f020d0400ffff

**Severity**

Info

**Serviceable**

No

**Automatically notify support**

No

**Alert Category**

System - Predicted Failure

**SNMP Trap ID**

27

**CIM Information**

Prefix: PLAT ID: 0169

**User Response**

No action; information only.

- **816f020d-0401ffff : Failure no longer Predicted on drive [StorageVolumeElementName] for array [ComputerSystemElementName]. (Drive 1)**

This message is for the use case when an implementation has detected an Array Failure is no longer Predicted.

May also be shown as 816f020d0401ffff or 0x816f020d0401ffff

**Severity**

Info

**Serviceable**

No

**Automatically notify support**

No

**Alert Category**

System - Predicted Failure

**SNMP Trap ID**

27

**CIM Information**

**Prefix:** PLAT ID: 0169

**User Response**

No action; information only.

- **816f020d-0402ffff : Failure no longer Predicted on drive [StorageVolumeElementName] for array [ComputerSystemElementName]. (Drive 2)**

This message is for the use case when an implementation has detected an Array Failure is no longer Predicted.

May also be shown as 816f020d0402ffff or 0x816f020d0402ffff

**Severity**

Info

**Serviceable**

No

**Automatically notify support**

No

**Alert Category**

System - Predicted Failure

**SNMP Trap ID**

27

**CIM Information**

**Prefix:** PLAT ID: 0169

**User Response**

No action; information only.

- **816f020d-0403ffff : Failure no longer Predicted on drive [StorageVolumeElementName] for array [ComputerSystemElementName]. (Drive 3)**

This message is for the use case when an implementation has detected an Array Failure is no longer Predicted.

May also be shown as 816f020d0403ffff or 0x816f020d0403ffff

**Severity**

Info

**Serviceable**

No

**Automatically notify support**

No

**Alert Category**

System - Predicted Failure

**SNMP Trap ID**

**CIM Information**

Prefix: PLAT ID: 0169

**User Response**

No action; information only.

- **816f020d-0404ffff : Failure no longer Predicted on drive [StorageVolumeElementName] for array [ComputerSystemElementName]. (Drive 4)**

This message is for the use case when an implementation has detected an Array Failure is no longer Predicted.

May also be shown as 816f020d0404ffff or 0x816f020d0404ffff

**Severity**

Info

**Serviceable**

No

**Automatically notify support**

No

**Alert Category**

System - Predicted Failure

**SNMP Trap ID**

27

**CIM Information**

Prefix: PLAT ID: 0169

**User Response**

No action; information only.

- **816f020d-0405ffff : Failure no longer Predicted on drive [StorageVolumeElementName] for array [ComputerSystemElementName]. (Drive 5)**

This message is for the use case when an implementation has detected an Array Failure is no longer Predicted.

May also be shown as 816f020d0405ffff or 0x816f020d0405ffff

**Severity**

Info

**Serviceable**

No

**Automatically notify support**

No

**Alert Category**

System - Predicted Failure

**SNMP Trap ID**

27

**CIM Information**

Prefix: PLAT ID: 0169

**User Response**

No action; information only.



- **816f020d-0406ffff : Failure no longer Predicted on drive [StorageVolumeElementName] for array [ComputerSystemElementName]. (Drive 6)**

This message is for the use case when an implementation has detected an Array Failure is no longer Predicted.

May also be shown as 816f020d0406ffff or 0x816f020d0406ffff

**Severity**

Info

**Serviceable**

No

**Automatically notify support**

No

**Alert Category**

System - Predicted Failure

**SNMP Trap ID**

27

**CIM Information**

**Prefix:** PLAT ID: 0169

**User Response**

No action; information only.

- **816f020d-0407ffff : Failure no longer Predicted on drive [StorageVolumeElementName] for array [ComputerSystemElementName]. (Drive 7)**

This message is for the use case when an implementation has detected an Array Failure is no longer Predicted.

May also be shown as 816f020d0407ffff or 0x816f020d0407ffff

**Severity**

Info

**Serviceable**

No

**Automatically notify support**

No

**Alert Category**

System - Predicted Failure

**SNMP Trap ID**

27

**CIM Information**

**Prefix:** PLAT ID: 0169

**User Response**

No action; information only.

- **816f020d-0408ffff : Failure no longer Predicted on drive [StorageVolumeElementName] for array [ComputerSystemElementName]. (Drive 8)**

This message is for the use case when an implementation has detected an Array Failure is no longer Predicted.

May also be shown as 816f020d0408ffff or 0x816f020d0408ffff

**Severity**

Info

**Serviceable**

No

**Automatically notify support**

No

**Alert Category**

System - Predicted Failure

**SNMP Trap ID**

27

**CIM Information**

**Prefix: PLAT ID:** 0169

**User Response**

No action; information only.

- **816f020d-0409ffff : Failure no longer Predicted on drive [StorageVolumeElementName] for array [ComputerSystemElementName]. (Drive 9)**

This message is for the use case when an implementation has detected an Array Failure is no longer Predicted.

May also be shown as 816f020d0409ffff or 0x816f020d0409ffff

**Severity**

Info

**Serviceable**

No

**Automatically notify support**

No

**Alert Category**

System - Predicted Failure

**SNMP Trap ID**

27

**CIM Information**

**Prefix: PLAT ID:** 0169

**User Response**

No action; information only.

- **816f020d-040affff : Failure no longer Predicted on drive [StorageVolumeElementName] for array [ComputerSystemElementName]. (Drive 10)**

This message is for the use case when an implementation has detected an Array Failure is no longer Predicted.

May also be shown as 816f020d040affff or 0x816f020d040affff

**Severity**

Info

**Serviceable**

No

**Automatically notify support**

No

**Alert Category**

System - Predicted Failure

**SNMP Trap ID**

27

**CIM Information**

**Prefix:** PLAT ID: 0169

**User Response**

No action; information only.

- **816f020d-040bffff : Failure no longer Predicted on drive [StorageVolumeElementName] for array [ComputerSystemElementName]. (Drive 11)**

This message is for the use case when an implementation has detected an Array Failure is no longer Predicted.

May also be shown as 816f020d040bffff or 0x816f020d040bffff

**Severity**

Info

**Serviceable**

No

**Automatically notify support**

No

**Alert Category**

System - Predicted Failure

**SNMP Trap ID**

27

**CIM Information**

**Prefix:** PLAT ID: 0169

**User Response**

No action; information only.

- **816f020d-040cffff : Failure no longer Predicted on drive [StorageVolumeElementName] for array [ComputerSystemElementName]. (Drive 12)**

This message is for the use case when an implementation has detected an Array Failure is no longer Predicted.

May also be shown as 816f020d040cffff or 0x816f020d040cffff

**Severity**

Info

**Serviceable**

No

**Automatically notify support**

No

**Alert Category**

System - Predicted Failure

**SNMP Trap ID**

27

**CIM Information**

**Prefix:** PLAT ID: 0169

**User Response**

No action; information only.

- **816f020d-040dffff : Failure no longer Predicted on drive [StorageVolumeElementName] for array [ComputerSystemElementName]. (Drive 13)**

This message is for the use case when an implementation has detected an Array Failure is no longer Predicted.

May also be shown as 816f020d040dffff or 0x816f020d040dffff

**Severity**

Info

**Serviceable**

No

**Automatically notify support**

No

**Alert Category**

System - Predicted Failure

**SNMP Trap ID**

27

**CIM Information**

**Prefix: PLAT ID:** 0169

**User Response**

No action; information only.

- **816f020d-040effff : Failure no longer Predicted on drive [StorageVolumeElementName] for array [ComputerSystemElementName]. (Drive 14)**

This message is for the use case when an implementation has detected an Array Failure is no longer Predicted.

May also be shown as 816f020d040effff or 0x816f020d040effff

**Severity**

Info

**Serviceable**

No

**Automatically notify support**

No

**Alert Category**

System - Predicted Failure

**SNMP Trap ID**

27

**CIM Information**

**Prefix: PLAT ID:** 0169

**User Response**

No action; information only.

- **816f020d-040fffff : Failure no longer Predicted on drive [StorageVolumeElementName] for array [ComputerSystemElementName]. (Drive 15)**

This message is for the use case when an implementation has detected an Array Failure is no longer Predicted.

May also be shown as 816f020d040fffff or 0x816f020d040fffff

**Severity**

Info

**Serviceable**

No

**Automatically notify support**

No

**Alert Category**

System - Predicted Failure

**SNMP Trap ID**

27

**CIM Information****Prefix: PLAT ID:** 0169**User Response**

No action; information only.

- **816f020d-0410ffff : Failure no longer Predicted on drive [StorageVolumeElementName] for array [ComputerSystemElementName]. (Drive 16)**

This message is for the use case when an implementation has detected an Array Failure is no longer Predicted.

May also be shown as 816f020d0410ffff or 0x816f020d0410ffff

**Severity**

Info

**Serviceable**

No

**Automatically notify support**

No

**Alert Category**

System - Predicted Failure

**SNMP Trap ID**

27

**CIM Information****Prefix: PLAT ID:** 0169**User Response**

No action; information only.

- **816f020d-0411ffff : Failure no longer Predicted on drive [StorageVolumeElementName] for array [ComputerSystemElementName]. (Drive 17)**

This message is for the use case when an implementation has detected an Array Failure is no longer Predicted.

May also be shown as 816f020d0411ffff or 0x816f020d0411ffff

**Severity**

Info

**Serviceable**

No

**Automatically notify support**

No

**Alert Category**

System - Predicted Failure

**SNMP Trap ID**

27

**CIM Information**

Prefix: PLAT ID: 0169

**User Response**

No action; information only.

- **816f020d-0412ffff : Failure no longer Predicted on drive [StorageVolumeElementName] for array [ComputerSystemElementName]. (Drive 18)**

This message is for the use case when an implementation has detected an Array Failure is no longer Predicted.

May also be shown as 816f020d0412ffff or 0x816f020d0412ffff

**Severity**

Info

**Serviceable**

No

**Automatically notify support**

No

**Alert Category**

System - Predicted Failure

**SNMP Trap ID**

27

**CIM Information**

Prefix: PLAT ID: 0169

**User Response**

No action; information only.

- **816f020d-0413ffff : Failure no longer Predicted on drive [StorageVolumeElementName] for array [ComputerSystemElementName]. (Drive 19)**

This message is for the use case when an implementation has detected an Array Failure is no longer Predicted.

May also be shown as 816f020d0413ffff or 0x816f020d0413ffff

**Severity**

Info

**Serviceable**

No

**Automatically notify support**

No

**Alert Category**

System - Predicted Failure

**SNMP Trap ID**

27

**CIM Information**

Prefix: PLAT ID: 0169

**User Response**

No action; information only.

- **816f020d-0414ffff : Failure no longer Predicted on drive [StorageVolumeElementName] for array [ComputerSystemElementName]. (Drive 20)**

This message is for the use case when an implementation has detected an Array Failure is no longer Predicted.

May also be shown as 816f020d0414ffff or 0x816f020d0414ffff

**Severity**

Info

**Serviceable**

No

**Automatically notify support**

No

**Alert Category**

System - Predicted Failure

**SNMP Trap ID**

27

**CIM Information**

**Prefix:** PLAT ID: 0169

**User Response**

No action; information only.

- **816f020d-0415ffff : Failure no longer Predicted on drive [StorageVolumeElementName] for array [ComputerSystemElementName]. (Drive 21)**

This message is for the use case when an implementation has detected an Array Failure is no longer Predicted.

May also be shown as 816f020d0415ffff or 0x816f020d0415ffff

**Severity**

Info

**Serviceable**

No

**Automatically notify support**

No

**Alert Category**

System - Predicted Failure

**SNMP Trap ID**

27

**CIM Information**

**Prefix:** PLAT ID: 0169

**User Response**

No action; information only.

- **816f020d-0416ffff : Failure no longer Predicted on drive [StorageVolumeElementName] for array [ComputerSystemElementName]. (Drive 22)**

This message is for the use case when an implementation has detected an Array Failure is no longer Predicted.

May also be shown as 816f020d0416ffff or 0x816f020d0416ffff

**Severity**

Info

**Serviceable**

No

**Automatically notify support**

No

**Alert Category**

System - Predicted Failure

**SNMP Trap ID**

27

**CIM Information****Prefix: PLAT ID:** 0169**User Response**

No action; information only.

- **816f020d-0417ffff : Failure no longer Predicted on drive [StorageVolumeElementName] for array [ComputerSystemElementName]. (Drive 23)**

This message is for the use case when an implementation has detected an Array Failure is no longer Predicted.

May also be shown as 816f020d0417ffff or 0x816f020d0417ffff

**Severity**

Info

**Serviceable**

No

**Automatically notify support**

No

**Alert Category**

System - Predicted Failure

**SNMP Trap ID**

27

**CIM Information****Prefix: PLAT ID:** 0169**User Response**

No action; information only.

- **816f020d-0418ffff : Failure no longer Predicted on drive [StorageVolumeElementName] for array [ComputerSystemElementName]. (Drive 24)**

This message is for the use case when an implementation has detected an Array Failure is no longer Predicted.

May also be shown as 816f020d0418ffff or 0x816f020d0418ffff

**Severity**

Info

**Serviceable**

No

**Automatically notify support**

No



**Alert Category**

System - Predicted Failure

**SNMP Trap ID**

27

**CIM Information**

**Prefix:** PLAT ID: 0169

**User Response**

No action; information only.

- **816f020d-0419ffff : Failure no longer Predicted on drive [StorageVolumeElementName] for array [ComputerSystemElementName]. (Drive 25)**

This message is for the use case when an implementation has detected an Array Failure is no longer Predicted.

May also be shown as 816f020d0419ffff or 0x816f020d0419ffff

**Severity**

Info

**Serviceable**

No

**Automatically notify support**

No

**Alert Category**

System - Predicted Failure

**SNMP Trap ID**

27

**CIM Information**

**Prefix:** PLAT ID: 0169

**User Response**

No action; information only.

- **816f020d-041affff : Failure no longer Predicted on drive [StorageVolumeElementName] for array [ComputerSystemElementName]. (Drive 26)**

This message is for the use case when an implementation has detected an Array Failure is no longer Predicted.

May also be shown as 816f020d041affff or 0x816f020d041affff

**Severity**

Info

**Serviceable**

No

**Automatically notify support**

No

**Alert Category**

System - Predicted Failure

**SNMP Trap ID**

27

**CIM Information**

**Prefix:** PLAT ID: 0169

**User Response**

No action; information only.

- **816f020d-041bffff : Failure no longer Predicted on drive [StorageVolumeElementName] for array [ComputerSystemElementName]. (Drive 27)**

This message is for the use case when an implementation has detected an Array Failure is no longer Predicted.

May also be shown as 816f020d041bffff or 0x816f020d041bffff

**Severity**

Info

**Serviceable**

No

**Automatically notify support**

No

**Alert Category**

System - Predicted Failure

**SNMP Trap ID**

27

**CIM Information**

Prefix: PLAT ID: 0169

**User Response**

No action; information only.

- **816f020d-041cffff : Failure no longer Predicted on drive [StorageVolumeElementName] for array [ComputerSystemElementName]. (Drive 28)**

This message is for the use case when an implementation has detected an Array Failure is no longer Predicted.

May also be shown as 816f020d041cffff or 0x816f020d041cffff

**Severity**

Info

**Serviceable**

No

**Automatically notify support**

No

**Alert Category**

System - Predicted Failure

**SNMP Trap ID**

27

**CIM Information**

Prefix: PLAT ID: 0169

**User Response**

No action; information only.

- **816f020d-041dffff : Failure no longer Predicted on drive [StorageVolumeElementName] for array [ComputerSystemElementName]. (Drive 29)**

This message is for the use case when an implementation has detected an Array Failure is no longer Predicted.

May also be shown as 816f020d041dffff or 0x816f020d041dffff

**Severity**

Info

**Serviceable**

No

**Automatically notify support**

No

**Alert Category**

System - Predicted Failure

**SNMP Trap ID**

27

**CIM Information****Prefix:** PLAT ID: 0169**User Response**

No action; information only.

- **816f020d-041efff : Failure no longer Predicted on drive [StorageVolumeElementName] for array [ComputerSystemElementName]. (Drive 30)**

This message is for the use case when an implementation has detected an Array Failure is no longer Predicted.

May also be shown as 816f020d041efff or 0x816f020d041efff

**Severity**

Info

**Serviceable**

No

**Automatically notify support**

No

**Alert Category**

System - Predicted Failure

**SNMP Trap ID**

27

**CIM Information****Prefix:** PLAT ID: 0169**User Response**

No action; information only.

- **816f020d-041ffff : Failure no longer Predicted on drive [StorageVolumeElementName] for array [ComputerSystemElementName]. (Drive 31)**

This message is for the use case when an implementation has detected an Array Failure is no longer Predicted.

May also be shown as 816f020d041ffff or 0x816f020d041ffff

**Severity**

Info

**Serviceable**

No

**Automatically notify support**

No

**Alert Category**

System - Predicted Failure

**SNMP Trap ID**

27

**CIM Information**

Prefix: PLAT ID: 0169

**User Response**

No action; information only.

- **816f020d-0420ffff : Failure no longer Predicted on drive [StorageVolumeElementName] for array [ComputerSystemElementName]. (Ext Drive)**

This message is for the use case when an implementation has detected an Array Failure is no longer Predicted.

May also be shown as 816f020d0420ffff or 0x816f020d0420ffff

**Severity**

Info

**Serviceable**

No

**Automatically notify support**

No

**Alert Category**

System - Predicted Failure

**SNMP Trap ID**

27

**CIM Information**

Prefix: PLAT ID: 0169

**User Response**

No action; information only.

- **816f0308-0a01ffff : [PowerSupplyElementName] has returned to a Normal Input State. (Power Supply 1)**

This message is for the use case when an implementation has detected a Power Supply that has input that has returned to normal.

May also be shown as 816f03080a01ffff or 0x816f03080a01ffff

**Severity**

Info

**Serviceable**

No

**Automatically notify support**

No

**Alert Category**

System - Other

**SNMP Trap ID****CIM Information**

Prefix: PLAT ID: 0099

**User Response**

No action; information only.

- **816f0308-0a02ffff : [PowerSupplyElementName] has returned to a Normal Input State. (Power Supply 2)**

This message is for the use case when an implementation has detected a Power Supply that has input that has returned to normal.

May also be shown as 816f03080a02ffff or 0x816f03080a02ffff

**Severity**

Info

**Serviceable**

No

**Automatically notify support**

No

**Alert Category**

System - Other

**SNMP Trap ID****CIM Information**

Prefix: PLAT ID: 0099

**User Response**

No action; information only.

- **816f030c-2001ffff : Scrub Failure for [PhysicalMemoryElementName] on Subsystem [MemoryElementName] has recovered. (DIMM 1)**

This message is for the use case when an implementation has detected a Memory Scrub failure recovery.

May also be shown as 816f030c2001ffff or 0x816f030c2001ffff

**Severity**

Info

**Serviceable**

No

**Automatically notify support**

No

**Alert Category**

Critical - Memory

**SNMP Trap ID**

41

**CIM Information**

Prefix: PLAT ID: 0137

**User Response**

No action; information only.

- **816f030c-2002ffff : Scrub Failure for [PhysicalMemoryElementName] on Subsystem [MemoryElementName] has recovered. (DIMM 2)**

This message is for the use case when an implementation has detected a Memory Scrub failure recovery.

May also be shown as 816f030c2002ffff or 0x816f030c2002ffff

**Severity**

Info

**Serviceable**

No

**Automatically notify support**

No

**Alert Category**

Critical - Memory

**SNMP Trap ID**

41

**CIM Information**

**Prefix: PLAT ID:** 0137

**User Response**

No action; information only.

- **816f030c-2003ffff : Scrub Failure for [PhysicalMemoryElementName] on Subsystem [MemoryElementName] has recovered. (DIMM 3)**

This message is for the use case when an implementation has detected a Memory Scrub failure recovery.

May also be shown as 816f030c2003ffff or 0x816f030c2003ffff

**Severity**

Info

**Serviceable**

No

**Automatically notify support**

No

**Alert Category**

Critical - Memory

**SNMP Trap ID**

41

**CIM Information**

**Prefix: PLAT ID:** 0137

**User Response**

No action; information only.

- **816f030c-2004ffff : Scrub Failure for [PhysicalMemoryElementName] on Subsystem [MemoryElementName] has recovered. (DIMM 4)**

This message is for the use case when an implementation has detected a Memory Scrub failure recovery.

May also be shown as 816f030c2004ffff or 0x816f030c2004ffff

**Severity**

Info

**Serviceable**

No

**Automatically notify support**

No

**Alert Category**

Critical - Memory

**SNMP Trap ID**

41

**CIM Information****Prefix:** PLAT ID: 0137**User Response**

No action; information only.

- **816f030c-2005ffff : Scrub Failure for [PhysicalMemoryElementName] on Subsystem [MemoryElementName] has recovered. (DIMM 5)**

This message is for the use case when an implementation has detected a Memory Scrub failure recovery.

May also be shown as 816f030c2005ffff or 0x816f030c2005ffff

**Severity**

Info

**Serviceable**

No

**Automatically notify support**

No

**Alert Category**

Critical - Memory

**SNMP Trap ID**

41

**CIM Information****Prefix:** PLAT ID: 0137**User Response**

No action; information only.

- **816f030c-2006ffff : Scrub Failure for [PhysicalMemoryElementName] on Subsystem [MemoryElementName] has recovered. (DIMM 6)**

This message is for the use case when an implementation has detected a Memory Scrub failure recovery.

May also be shown as 816f030c2006ffff or 0x816f030c2006ffff

**Severity**

Info

**Serviceable**

No

**Automatically notify support**

No

**Alert Category**

Critical - Memory

**SNMP Trap ID**

41

**CIM Information****Prefix:** PLAT ID: 0137**User Response**

No action; information only.

- **816f030c-2007ffff : Scrub Failure for [PhysicalMemoryElementName] on Subsystem [MemoryElementName] has recovered. (DIMM 7)**

This message is for the use case when an implementation has detected a Memory Scrub failure recovery.  
May also be shown as 816f030c2007ffff or 0x816f030c2007ffff

**Severity**

Info

**Serviceable**

No

**Automatically notify support**

No

**Alert Category**

Critical - Memory

**SNMP Trap ID**

41

**CIM Information**

Prefix: PLAT ID: 0137

**User Response**

No action; information only.

- **816f030c-2008ffff : Scrub Failure for [PhysicalMemoryElementName] on Subsystem [MemoryElementName] has recovered. (DIMM 8)**

This message is for the use case when an implementation has detected a Memory Scrub failure recovery.

May also be shown as 816f030c2008ffff or 0x816f030c2008ffff

**Severity**

Info

**Serviceable**

No

**Automatically notify support**

No

**Alert Category**

Critical - Memory

**SNMP Trap ID**

41

**CIM Information**

Prefix: PLAT ID: 0137

**User Response**

No action; information only.

- **816f030c-2009ffff : Scrub Failure for [PhysicalMemoryElementName] on Subsystem [MemoryElementName] has recovered. (DIMM 9)**

This message is for the use case when an implementation has detected a Memory Scrub failure recovery.

May also be shown as 816f030c2009ffff or 0x816f030c2009ffff

**Severity**

Info

**Serviceable**

No

**Automatically notify support**



No

**Alert Category**

Critical - Memory

**SNMP Trap ID**

41

**CIM Information**

**Prefix:** PLAT ID: 0137

**User Response**

No action; information only.

- **816f030c-200affff : Scrub Failure for [PhysicalMemoryElementName] on Subsystem [MemoryElementName] has recovered. (DIMM 10)**

This message is for the use case when an implementation has detected a Memory Scrub failure recovery.

May also be shown as 816f030c200affff or 0x816f030c200affff

**Severity**

Info

**Serviceable**

No

**Automatically notify support**

No

**Alert Category**

Critical - Memory

**SNMP Trap ID**

41

**CIM Information**

**Prefix:** PLAT ID: 0137

**User Response**

No action; information only.

- **816f030c-200bffff : Scrub Failure for [PhysicalMemoryElementName] on Subsystem [MemoryElementName] has recovered. (DIMM 11)**

This message is for the use case when an implementation has detected a Memory Scrub failure recovery.

May also be shown as 816f030c200bffff or 0x816f030c200bffff

**Severity**

Info

**Serviceable**

No

**Automatically notify support**

No

**Alert Category**

Critical - Memory

**SNMP Trap ID**

41

**CIM Information**

**Prefix:** PLAT ID: 0137

**User Response**

No action; information only.

- **816f030c-200cffff : Scrub Failure for [PhysicalMemoryElementName] on Subsystem [MemoryElementName] has recovered. (DIMM 12)**

This message is for the use case when an implementation has detected a Memory Scrub failure recovery. May also be shown as 816f030c200cffff or 0x816f030c200cffff

**Severity**

Info

**Serviceable**

No

**Automatically notify support**

No

**Alert Category**

Critical - Memory

**SNMP Trap ID**

41

**CIM Information**

Prefix: PLAT ID: 0137

**User Response**

No action; information only.

- **816f030c-200dffff : Scrub Failure for [PhysicalMemoryElementName] on Subsystem [MemoryElementName] has recovered. (DIMM 13)**

This message is for the use case when an implementation has detected a Memory Scrub failure recovery. May also be shown as 816f030c200dffff or 0x816f030c200dffff

**Severity**

Info

**Serviceable**

No

**Automatically notify support**

No

**Alert Category**

Critical - Memory

**SNMP Trap ID**

41

**CIM Information**

Prefix: PLAT ID: 0137

**User Response**

No action; information only.

- **816f030c-200effff : Scrub Failure for [PhysicalMemoryElementName] on Subsystem [MemoryElementName] has recovered. (DIMM 14)**

This message is for the use case when an implementation has detected a Memory Scrub failure recovery. May also be shown as 816f030c200effff or 0x816f030c200effff

**Severity**

Info

**Serviceable**

No

**Automatically notify support**

No

**Alert Category**

Critical - Memory

**SNMP Trap ID**

41

**CIM Information**

**Prefix:** PLAT ID: 0137

**User Response**

No action; information only.

- **816f030c-200ffff : Scrub Failure for [PhysicalMemoryElementName] on Subsystem [MemoryElementName] has recovered. (DIMM 15)**

This message is for the use case when an implementation has detected a Memory Scrub failure recovery.

May also be shown as 816f030c200ffff or 0x816f030c200ffff

**Severity**

Info

**Serviceable**

No

**Automatically notify support**

No

**Alert Category**

Critical - Memory

**SNMP Trap ID**

41

**CIM Information**

**Prefix:** PLAT ID: 0137

**User Response**

No action; information only.

- **816f030c-2010fff : Scrub Failure for [PhysicalMemoryElementName] on Subsystem [MemoryElementName] has recovered. (DIMM 16)**

This message is for the use case when an implementation has detected a Memory Scrub failure recovery.

May also be shown as 816f030c2010fff or 0x816f030c2010fff

**Severity**

Info

**Serviceable**

No

**Automatically notify support**

No

**Alert Category**

Critical - Memory

**SNMP Trap ID**

41

**CIM Information**

Prefix: PLAT ID: 0137

**User Response**

No action; information only.

- **816f030c-2011ffff : Scrub Failure for [PhysicalMemoryElementName] on Subsystem [MemoryElementName] has recovered. (DIMM 17)**

This message is for the use case when an implementation has detected a Memory Scrub failure recovery.

May also be shown as 816f030c2011ffff or 0x816f030c2011ffff

**Severity**

Info

**Serviceable**

No

**Automatically notify support**

No

**Alert Category**

Critical - Memory

**SNMP Trap ID**

41

**CIM Information**

Prefix: PLAT ID: 0137

**User Response**

No action; information only.

- **816f030c-2012ffff : Scrub Failure for [PhysicalMemoryElementName] on Subsystem [MemoryElementName] has recovered. (DIMM 18)**

This message is for the use case when an implementation has detected a Memory Scrub failure recovery.

May also be shown as 816f030c2012ffff or 0x816f030c2012ffff

**Severity**

Info

**Serviceable**

No

**Automatically notify support**

No

**Alert Category**

Critical - Memory

**SNMP Trap ID**

41

**CIM Information**

Prefix: PLAT ID: 0137

**User Response**

No action; information only.

- **816f030c-2013ffff : Scrub Failure for [PhysicalMemoryElementName] on Subsystem [MemoryElementName] has recovered. (DIMM 19)**

This message is for the use case when an implementation has detected a Memory Scrub failure recovery.

May also be shown as 816f030c2013ffff or 0x816f030c2013ffff

**Severity**

Info

**Serviceable**

No

**Automatically notify support**

No

**Alert Category**

Critical - Memory

**SNMP Trap ID**

41

**CIM Information****Prefix:** PLAT ID: 0137**User Response**

No action; information only.

- **816f030c-2014ffff : Scrub Failure for [PhysicalMemoryElementName] on Subsystem [MemoryElementName] has recovered. (DIMM 20)**

This message is for the use case when an implementation has detected a Memory Scrub failure recovery.

May also be shown as 816f030c2014ffff or 0x816f030c2014ffff

**Severity**

Info

**Serviceable**

No

**Automatically notify support**

No

**Alert Category**

Critical - Memory

**SNMP Trap ID**

41

**CIM Information****Prefix:** PLAT ID: 0137**User Response**

No action; information only.

- **816f030c-2015ffff : Scrub Failure for [PhysicalMemoryElementName] on Subsystem [MemoryElementName] has recovered. (DIMM 21)**

This message is for the use case when an implementation has detected a Memory Scrub failure recovery.

May also be shown as 816f030c2015ffff or 0x816f030c2015ffff

**Severity**

Info

**Serviceable**

No

**Automatically notify support**

No

**Alert Category**

Critical - Memory

**SNMP Trap ID**

41

**CIM Information**

Prefix: PLAT ID: 0137

**User Response**

No action; information only.

- **816f030c-2016ffff : Scrub Failure for [PhysicalMemoryElementName] on Subsystem [MemoryElementName] has recovered. (DIMM 22)**

This message is for the use case when an implementation has detected a Memory Scrub failure recovery.

May also be shown as 816f030c2016ffff or 0x816f030c2016ffff

**Severity**

Info

**Serviceable**

No

**Automatically notify support**

No

**Alert Category**

Critical - Memory

**SNMP Trap ID**

41

**CIM Information**

Prefix: PLAT ID: 0137

**User Response**

No action; information only.

- **816f030c-2017ffff : Scrub Failure for [PhysicalMemoryElementName] on Subsystem [MemoryElementName] has recovered. (DIMM 23)**

This message is for the use case when an implementation has detected a Memory Scrub failure recovery.

May also be shown as 816f030c2017ffff or 0x816f030c2017ffff

**Severity**

Info

**Serviceable**

No

**Automatically notify support**

No

**Alert Category**

Critical - Memory

**SNMP Trap ID**

41

**CIM Information**

Prefix: PLAT ID: 0137

**User Response**

No action; information only.

- **816f030c-2018ffff : Scrub Failure for [PhysicalMemoryElementName] on Subsystem [MemoryElementName] has recovered. (DIMM 24)**

This message is for the use case when an implementation has detected a Memory Scrub failure recovery.  
May also be shown as 816f030c2018ffff or 0x816f030c2018ffff

**Severity**

Info

**Serviceable**

No

**Automatically notify support**

No

**Alert Category**

Critical - Memory

**SNMP Trap ID**

41

**CIM Information**

Prefix: PLAT ID: 0137

**User Response**

No action; information only.

- **816f030c-2581ffff : Scrub Failure for [PhysicalMemoryElementName] on Subsystem [MemoryElementName] has recovered. (All DIMMS)**

This message is for the use case when an implementation has detected a Memory Scrub failure recovery.

May also be shown as 816f030c2581ffff or 0x816f030c2581ffff

**Severity**

Info

**Serviceable**

No

**Automatically notify support**

No

**Alert Category**

Critical - Memory

**SNMP Trap ID**

41

**CIM Information**

Prefix: PLAT ID: 0137

**User Response**

No action; information only. One of the DIMMs :

- **816f030d-0400ffff : Hot spare disabled for [ComputerSystemElementName]. (Drive 0)**

This message is for the use case when an implementation has detected a Hot Spare has been Disabled.

May also be shown as 816f030d0400ffff or 0x816f030d0400ffff

**Severity**

Info

**Serviceable**

No

**Automatically notify support**

No

**Alert Category**  
System - Other

**SNMP Trap ID**

**CIM Information**  
Prefix: PLAT ID: 0171

**User Response**  
No action; information only.

- **816f030d-0401ffff : Hot spare disabled for [ComputerSystemElementName]. (Drive 1)**

This message is for the use case when an implementation has detected a Hot Spare has been Disabled.  
May also be shown as 816f030d0401ffff or 0x816f030d0401ffff

**Severity**  
Info

**Serviceable**  
No

**Automatically notify support**  
No

**Alert Category**  
System - Other

**SNMP Trap ID**

**CIM Information**  
Prefix: PLAT ID: 0171

**User Response**  
No action; information only.

- **816f030d-0402ffff : Hot spare disabled for [ComputerSystemElementName]. (Drive 2)**

This message is for the use case when an implementation has detected a Hot Spare has been Disabled.  
May also be shown as 816f030d0402ffff or 0x816f030d0402ffff

**Severity**  
Info

**Serviceable**  
No

**Automatically notify support**  
No

**Alert Category**  
System - Other

**SNMP Trap ID**

**CIM Information**  
Prefix: PLAT ID: 0171

**User Response**  
No action; information only.

- **816f030d-0403ffff : Hot spare disabled for [ComputerSystemElementName]. (Drive 3)**

This message is for the use case when an implementation has detected a Hot Spare has been Disabled.



May also be shown as 816f030d0403ffff or 0x816f030d0403ffff

**Severity**

Info

**Serviceable**

No

**Automatically notify support**

No

**Alert Category**

System - Other

**SNMP Trap ID**

**CIM Information**

**Prefix:** PLAT ID: 0171

**User Response**

No action; information only.

- **816f030d-0404ffff : Hot spare disabled for [ComputerSystemElementName]. (Drive 4)**

This message is for the use case when an implementation has detected a Hot Spare has been Disabled.

May also be shown as 816f030d0404ffff or 0x816f030d0404ffff

**Severity**

Info

**Serviceable**

No

**Automatically notify support**

No

**Alert Category**

System - Other

**SNMP Trap ID**

**CIM Information**

**Prefix:** PLAT ID: 0171

**User Response**

No action; information only.

- **816f030d-0405ffff : Hot spare disabled for [ComputerSystemElementName]. (Drive 5)**

This message is for the use case when an implementation has detected a Hot Spare has been Disabled.

May also be shown as 816f030d0405ffff or 0x816f030d0405ffff

**Severity**

Info

**Serviceable**

No

**Automatically notify support**

No

**Alert Category**

System - Other

## SNMP Trap ID

### CIM Information

Prefix: PLAT ID: 0171

### User Response

No action; information only.

- **816f030d-0406ffff : Hot spare disabled for [ComputerSystemElementName]. (Drive 6)**

This message is for the use case when an implementation has detected a Hot Spare has been Disabled.

May also be shown as 816f030d0406ffff or 0x816f030d0406ffff

### Severity

Info

### Serviceable

No

### Automatically notify support

No

### Alert Category

System - Other

## SNMP Trap ID

### CIM Information

Prefix: PLAT ID: 0171

### User Response

No action; information only.

- **816f030d-0407ffff : Hot spare disabled for [ComputerSystemElementName]. (Drive 7)**

This message is for the use case when an implementation has detected a Hot Spare has been Disabled.

May also be shown as 816f030d0407ffff or 0x816f030d0407ffff

### Severity

Info

### Serviceable

No

### Automatically notify support

No

### Alert Category

System - Other

## SNMP Trap ID

### CIM Information

Prefix: PLAT ID: 0171

### User Response

No action; information only.

- **816f030d-0408ffff : Hot spare disabled for [ComputerSystemElementName]. (Drive 8)**

This message is for the use case when an implementation has detected a Hot Spare has been Disabled.

May also be shown as 816f030d0408ffff or 0x816f030d0408ffff

**Severity**

Info

**Serviceable**

No

**Automatically notify support**

No

**Alert Category**

System - Other

**SNMP Trap ID****CIM Information****Prefix:** PLAT ID: 0171**User Response**

No action; information only.

- **816f030d-0409ffff : Hot spare disabled for [ComputerSystemElementName]. (Drive 9)**

This message is for the use case when an implementation has detected a Hot Spare has been Disabled.

May also be shown as 816f030d0409ffff or 0x816f030d0409ffff

**Severity**

Info

**Serviceable**

No

**Automatically notify support**

No

**Alert Category**

System - Other

**SNMP Trap ID****CIM Information****Prefix:** PLAT ID: 0171**User Response**

No action; information only.

- **816f030d-040affff : Hot spare disabled for [ComputerSystemElementName]. (Drive 10)**

This message is for the use case when an implementation has detected a Hot Spare has been Disabled.

May also be shown as 816f030d040affff or 0x816f030d040affff

**Severity**

Info

**Serviceable**

No

**Automatically notify support**

No

**Alert Category**

System - Other

**SNMP Trap ID**

**CIM Information**

Prefix: PLAT ID: 0171

**User Response**

No action; information only.

- **816f030d-040bffff : Hot spare disabled for [ComputerSystemElementName]. (Drive 11)**

This message is for the use case when an implementation has detected a Hot Spare has been Disabled.

May also be shown as 816f030d040bffff or 0x816f030d040bffff

**Severity**

Info

**Serviceable**

No

**Automatically notify support**

No

**Alert Category**

System - Other

**SNMP Trap ID****CIM Information**

Prefix: PLAT ID: 0171

**User Response**

No action; information only.

- **816f030d-040cffff : Hot spare disabled for [ComputerSystemElementName]. (Drive 12)**

This message is for the use case when an implementation has detected a Hot Spare has been Disabled.

May also be shown as 816f030d040cffff or 0x816f030d040cffff

**Severity**

Info

**Serviceable**

No

**Automatically notify support**

No

**Alert Category**

System - Other

**SNMP Trap ID****CIM Information**

Prefix: PLAT ID: 0171

**User Response**

No action; information only.

- **816f030d-040dffff : Hot spare disabled for [ComputerSystemElementName]. (Drive 13)**

This message is for the use case when an implementation has detected a Hot Spare has been Disabled.

May also be shown as 816f030d040dffff or 0x816f030d040dffff

**Severity**

Info

**Serviceable**

No

**Automatically notify support**

No

**Alert Category**

System - Other

**SNMP Trap ID****CIM Information**

Prefix: PLAT ID: 0171

**User Response**

No action; information only.

- **816f030d-040effff : Hot spare disabled for [ComputerSystemElementName]. (Drive 14)**

This message is for the use case when an implementation has detected a Hot Spare has been Disabled.

May also be shown as 816f030d040effff or 0x816f030d040effff

**Severity**

Info

**Serviceable**

No

**Automatically notify support**

No

**Alert Category**

System - Other

**SNMP Trap ID****CIM Information**

Prefix: PLAT ID: 0171

**User Response**

No action; information only.

- **816f030d-040fffff : Hot spare disabled for [ComputerSystemElementName]. (Drive 15)**

This message is for the use case when an implementation has detected a Hot Spare has been Disabled.

May also be shown as 816f030d040fffff or 0x816f030d040fffff

**Severity**

Info

**Serviceable**

No

**Automatically notify support**

No

**Alert Category**

System - Other

**SNMP Trap ID****CIM Information**

Prefix: PLAT ID: 0171

**User Response**

No action; information only.

- **816f030d-0410ffff : Hot spare disabled for [ComputerSystemElementName]. (Drive 16)**

This message is for the use case when an implementation has detected a Hot Spare has been Disabled.

May also be shown as 816f030d0410ffff or 0x816f030d0410ffff

**Severity**

Info

**Serviceable**

No

**Automatically notify support**

No

**Alert Category**

System - Other

**SNMP Trap ID****CIM Information**

Prefix: PLAT ID: 0171

**User Response**

No action; information only.

- **816f030d-0411ffff : Hot spare disabled for [ComputerSystemElementName]. (Drive 17)**

This message is for the use case when an implementation has detected a Hot Spare has been Disabled.

May also be shown as 816f030d0411ffff or 0x816f030d0411ffff

**Severity**

Info

**Serviceable**

No

**Automatically notify support**

No

**Alert Category**

System - Other

**SNMP Trap ID****CIM Information**

Prefix: PLAT ID: 0171

**User Response**

No action; information only.

- **816f030d-0412ffff : Hot spare disabled for [ComputerSystemElementName]. (Drive 18)**

This message is for the use case when an implementation has detected a Hot Spare has been Disabled.

May also be shown as 816f030d0412ffff or 0x816f030d0412ffff

**Severity**

Info

**Serviceable**

No

**Automatically notify support**

No

**Alert Category**

System - Other

**SNMP Trap ID**

**CIM Information**

Prefix: PLAT ID: 0171

**User Response**

No action; information only.

- **816f030d-0413ffff : Hot spare disabled for [ComputerSystemElementName]. (Drive 19)**

This message is for the use case when an implementation has detected a Hot Spare has been Disabled.

May also be shown as 816f030d0413ffff or 0x816f030d0413ffff

**Severity**

Info

**Serviceable**

No

**Automatically notify support**

No

**Alert Category**

System - Other

**SNMP Trap ID**

**CIM Information**

Prefix: PLAT ID: 0171

**User Response**

No action; information only.

- **816f030d-0414ffff : Hot spare disabled for [ComputerSystemElementName]. (Drive 20)**

This message is for the use case when an implementation has detected a Hot Spare has been Disabled.

May also be shown as 816f030d0414ffff or 0x816f030d0414ffff

**Severity**

Info

**Serviceable**

No

**Automatically notify support**

No

**Alert Category**

System - Other

**SNMP Trap ID**

**CIM Information**

Prefix: PLAT ID: 0171

**User Response**

No action; information only.

- **816f030d-0415ffff : Hot spare disabled for [ComputerSystemElementName]. (Drive 21)**

This message is for the use case when an implementation has detected a Hot Spare has been Disabled.

May also be shown as 816f030d0415ffff or 0x816f030d0415ffff

**Severity**

Info

**Serviceable**

No

**Automatically notify support**

No

**Alert Category**

System - Other

**SNMP Trap ID**

**CIM Information**

Prefix: PLAT ID: 0171

**User Response**

No action; information only.

- **816f030d-0416ffff : Hot spare disabled for [ComputerSystemElementName]. (Drive 22)**

This message is for the use case when an implementation has detected a Hot Spare has been Disabled.

May also be shown as 816f030d0416ffff or 0x816f030d0416ffff

**Severity**

Info

**Serviceable**

No

**Automatically notify support**

No

**Alert Category**

System - Other

**SNMP Trap ID**

**CIM Information**

Prefix: PLAT ID: 0171

**User Response**

No action; information only.

- **816f030d-0417ffff : Hot spare disabled for [ComputerSystemElementName]. (Drive 23)**

This message is for the use case when an implementation has detected a Hot Spare has been Disabled.

May also be shown as 816f030d0417ffff or 0x816f030d0417ffff

**Severity**

Info

**Serviceable**

No

**Automatically notify support**



No

**Alert Category**

System - Other

**SNMP Trap ID**

**CIM Information**

Prefix: PLAT ID: 0171

**User Response**

No action; information only.

- **816f030d-0418ffff : Hot spare disabled for [ComputerSystemElementName]. (Drive 24)**

This message is for the use case when an implementation has detected a Hot Spare has been Disabled.

May also be shown as 816f030d0418ffff or 0x816f030d0418ffff

**Severity**

Info

**Serviceable**

No

**Automatically notify support**

No

**Alert Category**

System - Other

**SNMP Trap ID**

**CIM Information**

Prefix: PLAT ID: 0171

**User Response**

No action; information only.

- **816f030d-0419ffff : Hot spare disabled for [ComputerSystemElementName]. (Drive 25)**

This message is for the use case when an implementation has detected a Hot Spare has been Disabled.

May also be shown as 816f030d0419ffff or 0x816f030d0419ffff

**Severity**

Info

**Serviceable**

No

**Automatically notify support**

No

**Alert Category**

System - Other

**SNMP Trap ID**

**CIM Information**

Prefix: PLAT ID: 0171

**User Response**

No action; information only.

- **816f030d-041affff : Hot spare disabled for [ComputerSystemElementName]. (Drive 26)**

This message is for the use case when an implementation has detected a Hot Spare has been Disabled.  
May also be shown as 816f030d041affff or 0x816f030d041affff

**Severity**

Info

**Serviceable**

No

**Automatically notify support**

No

**Alert Category**

System - Other

**SNMP Trap ID**

**CIM Information**

Prefix: PLAT ID: 0171

**User Response**

No action; information only.

- **816f030d-041bffff : Hot spare disabled for [ComputerSystemElementName]. (Drive 27)**

This message is for the use case when an implementation has detected a Hot Spare has been Disabled.  
May also be shown as 816f030d041bffff or 0x816f030d041bffff

**Severity**

Info

**Serviceable**

No

**Automatically notify support**

No

**Alert Category**

System - Other

**SNMP Trap ID**

**CIM Information**

Prefix: PLAT ID: 0171

**User Response**

No action; information only.

- **816f030d-041cffff : Hot spare disabled for [ComputerSystemElementName]. (Drive 28)**

This message is for the use case when an implementation has detected a Hot Spare has been Disabled.  
May also be shown as 816f030d041cffff or 0x816f030d041cffff

**Severity**

Info

**Serviceable**

No

**Automatically notify support**

No

**Alert Category**

System - Other

**SNMP Trap ID****CIM Information**

Prefix: PLAT ID: 0171

**User Response**

No action; information only.

- **816f030d-041dffff : Hot spare disabled for [ComputerSystemElementName]. (Drive 29)**

This message is for the use case when an implementation has detected a Hot Spare has been Disabled.

May also be shown as 816f030d041dffff or 0x816f030d041dffff

**Severity**

Info

**Serviceable**

No

**Automatically notify support**

No

**Alert Category**

System - Other

**SNMP Trap ID****CIM Information**

Prefix: PLAT ID: 0171

**User Response**

No action; information only.

- **816f030d-041effff : Hot spare disabled for [ComputerSystemElementName]. (Drive 30)**

This message is for the use case when an implementation has detected a Hot Spare has been Disabled.

May also be shown as 816f030d041effff or 0x816f030d041effff

**Severity**

Info

**Serviceable**

No

**Automatically notify support**

No

**Alert Category**

System - Other

**SNMP Trap ID****CIM Information**

Prefix: PLAT ID: 0171

**User Response**

No action; information only.

- **816f030d-041fffff : Hot spare disabled for [ComputerSystemElementName]. (Drive 31)**

This message is for the use case when an implementation has detected a Hot Spare has been Disabled.

May also be shown as 816f030d041ffff or 0x816f030d041ffff

**Severity**

Info

**Serviceable**

No

**Automatically notify support**

No

**Alert Category**

System - Other

**SNMP Trap ID**

**CIM Information**

Prefix: PLAT ID: 0171

**User Response**

No action; information only.

- **816f030d-0420ffff : Hot spare disabled for [ComputerSystemElementName]. (Ext Drive)**

This message is for the use case when an implementation has detected a Hot Spare has been Disabled.

May also be shown as 816f030d0420ffff or 0x816f030d0420ffff

**Severity**

Info

**Serviceable**

No

**Automatically notify support**

No

**Alert Category**

System - Other

**SNMP Trap ID**

**CIM Information**

Prefix: PLAT ID: 0171

**User Response**

No action; information only.

- **816f0313-1701ffff : System [ComputerSystemElementName] has recovered from an NMI. (NMI State)**

This message is for the use case when an implementation has detected a Software NMI has been Recovered from.

May also be shown as 816f03131701ffff or 0x816f03131701ffff

**Severity**

Info

**Serviceable**

No

**Automatically notify support**

No

**Alert Category**

Critical - Other

**SNMP Trap ID**

50

**CIM Information**

**Prefix:** PLAT ID: 0230

**User Response**

No action; information only.

- **816f040c-2001ffff : [PhysicalMemoryElementName] Enabled on Subsystem [MemoryElementName]. (DIMM 1)**

This message is for the use case when an implementation has detected that Memory has been Enabled.

May also be shown as 816f040c2001ffff or 0x816f040c2001ffff

**Severity**

Info

**Serviceable**

No

**Automatically notify support**

No

**Alert Category**

System - Other

**SNMP Trap ID****CIM Information**

**Prefix:** PLAT ID: 0130

**User Response**

No action; information only.

- **816f040c-2002ffff : [PhysicalMemoryElementName] Enabled on Subsystem [MemoryElementName]. (DIMM 2)**

This message is for the use case when an implementation has detected that Memory has been Enabled.

May also be shown as 816f040c2002ffff or 0x816f040c2002ffff

**Severity**

Info

**Serviceable**

No

**Automatically notify support**

No

**Alert Category**

System - Other

**SNMP Trap ID****CIM Information**

**Prefix:** PLAT ID: 0130

**User Response**

No action; information only.

- **816f040c-2003ffff : [PhysicalMemoryElementName] Enabled on Subsystem [MemoryElementName]. (DIMM 3)**

This message is for the use case when an implementation has detected that Memory has been Enabled.  
May also be shown as 816f040c2003ffff or 0x816f040c2003ffff

**Severity**

Info

**Serviceable**

No

**Automatically notify support**

No

**Alert Category**

System - Other

**SNMP Trap ID**

**CIM Information**

Prefix: PLAT ID: 0130

**User Response**

No action; information only.

- **816f040c-2004ffff : [PhysicalMemoryElementName] Enabled on Subsystem [MemoryElementName]. (DIMM 4)**

This message is for the use case when an implementation has detected that Memory has been Enabled.  
May also be shown as 816f040c2004ffff or 0x816f040c2004ffff

**Severity**

Info

**Serviceable**

No

**Automatically notify support**

No

**Alert Category**

System - Other

**SNMP Trap ID**

**CIM Information**

Prefix: PLAT ID: 0130

**User Response**

No action; information only.

- **816f040c-2005ffff : [PhysicalMemoryElementName] Enabled on Subsystem [MemoryElementName]. (DIMM 5)**

This message is for the use case when an implementation has detected that Memory has been Enabled.  
May also be shown as 816f040c2005ffff or 0x816f040c2005ffff

**Severity**

Info

**Serviceable**

No

**Automatically notify support**

No

**Alert Category**

System - Other

**SNMP Trap ID**

**CIM Information**

**Prefix:** PLAT ID: 0130

**User Response**

No action; information only.

- **816f040c-2006ffff : [PhysicalMemoryElementName] Enabled on Subsystem [MemoryElementName]. (DIMM 6)**

This message is for the use case when an implementation has detected that Memory has been Enabled.

May also be shown as 816f040c2006ffff or 0x816f040c2006ffff

**Severity**

Info

**Serviceable**

No

**Automatically notify support**

No

**Alert Category**

System - Other

**SNMP Trap ID**

**CIM Information**

**Prefix:** PLAT ID: 0130

**User Response**

No action; information only.

- **816f040c-2007ffff : [PhysicalMemoryElementName] Enabled on Subsystem [MemoryElementName]. (DIMM 7)**

This message is for the use case when an implementation has detected that Memory has been Enabled.

May also be shown as 816f040c2007ffff or 0x816f040c2007ffff

**Severity**

Info

**Serviceable**

No

**Automatically notify support**

No

**Alert Category**

System - Other

**SNMP Trap ID**

**CIM Information**

**Prefix: PLAT ID: 0130**

**User Response**

No action; information only.

- **816f040c-2008ffff : [PhysicalMemoryElementName] Enabled on Subsystem [MemoryElementName]. (DIMM 8)**

This message is for the use case when an implementation has detected that Memory has been Enabled.

May also be shown as 816f040c2008ffff or 0x816f040c2008ffff

**Severity**

Info

**Serviceable**

No

**Automatically notify support**

No

**Alert Category**

System - Other

**SNMP Trap ID**

**CIM Information**

**Prefix: PLAT ID: 0130**

**User Response**

No action; information only.

- **816f040c-2009ffff : [PhysicalMemoryElementName] Enabled on Subsystem [MemoryElementName]. (DIMM 9)**

This message is for the use case when an implementation has detected that Memory has been Enabled.

May also be shown as 816f040c2009ffff or 0x816f040c2009ffff

**Severity**

Info

**Serviceable**

No

**Automatically notify support**

No

**Alert Category**

System - Other

**SNMP Trap ID**

**CIM Information**

**Prefix: PLAT ID: 0130**

**User Response**

No action; information only.

- **816f040c-200affff : [PhysicalMemoryElementName] Enabled on Subsystem [MemoryElementName]. (DIMM 10)**

This message is for the use case when an implementation has detected that Memory has been Enabled.

May also be shown as 816f040c200affff or 0x816f040c200affff



**Severity**

Info

**Serviceable**

No

**Automatically notify support**

No

**Alert Category**

System - Other

**SNMP Trap ID****CIM Information**

Prefix: PLAT ID: 0130

**User Response**

No action; information only.

- **816f040c-200bfff : [PhysicalMemoryElementName] Enabled on Subsystem [MemoryElementName]. (DIMM 11)**

This message is for the use case when an implementation has detected that Memory has been Enabled.

May also be shown as 816f040c200bfff or 0x816f040c200bfff

**Severity**

Info

**Serviceable**

No

**Automatically notify support**

No

**Alert Category**

System - Other

**SNMP Trap ID****CIM Information**

Prefix: PLAT ID: 0130

**User Response**

No action; information only.

- **816f040c-200cfff : [PhysicalMemoryElementName] Enabled on Subsystem [MemoryElementName]. (DIMM 12)**

This message is for the use case when an implementation has detected that Memory has been Enabled.

May also be shown as 816f040c200cfff or 0x816f040c200cfff

**Severity**

Info

**Serviceable**

No

**Automatically notify support**

No

**Alert Category**

System - Other

## SNMP Trap ID

### CIM Information

Prefix: PLAT ID: 0130

### User Response

No action; information only.

- **816f040c-200dffff : [PhysicalMemoryElementName] Enabled on Subsystem [MemoryElementName]. (DIMM 13)**

This message is for the use case when an implementation has detected that Memory has been Enabled.

May also be shown as 816f040c200dffff or 0x816f040c200dffff

### Severity

Info

### Serviceable

No

### Automatically notify support

No

### Alert Category

System - Other

## SNMP Trap ID

### CIM Information

Prefix: PLAT ID: 0130

### User Response

No action; information only.

- **816f040c-200effff : [PhysicalMemoryElementName] Enabled on Subsystem [MemoryElementName]. (DIMM 14)**

This message is for the use case when an implementation has detected that Memory has been Enabled.

May also be shown as 816f040c200effff or 0x816f040c200effff

### Severity

Info

### Serviceable

No

### Automatically notify support

No

### Alert Category

System - Other

## SNMP Trap ID

### CIM Information

Prefix: PLAT ID: 0130

### User Response

No action; information only.

- **816f040c-200fffff : [PhysicalMemoryElementName] Enabled on Subsystem [MemoryElementName]. (DIMM 15)**

This message is for the use case when an implementation has detected that Memory has been Enabled.  
May also be shown as 816f040c200ffff or 0x816f040c200ffff

**Severity**

Info

**Serviceable**

No

**Automatically notify support**

No

**Alert Category**

System - Other

**SNMP Trap ID**

**CIM Information**

Prefix: PLAT ID: 0130

**User Response**

No action; information only.

- **816f040c-2010ffff : [PhysicalMemoryElementName] Enabled on Subsystem [MemoryElementName]. (DIMM 16)**

This message is for the use case when an implementation has detected that Memory has been Enabled.

May also be shown as 816f040c2010ffff or 0x816f040c2010ffff

**Severity**

Info

**Serviceable**

No

**Automatically notify support**

No

**Alert Category**

System - Other

**SNMP Trap ID**

**CIM Information**

Prefix: PLAT ID: 0130

**User Response**

No action; information only.

- **816f040c-2011ffff : [PhysicalMemoryElementName] Enabled on Subsystem [MemoryElementName]. (DIMM 17)**

This message is for the use case when an implementation has detected that Memory has been Enabled.

May also be shown as 816f040c2011ffff or 0x816f040c2011ffff

**Severity**

Info

**Serviceable**

No

**Automatically notify support**

No

**Alert Category**

System - Other

**SNMP Trap ID**

**CIM Information**

Prefix: PLAT ID: 0130

**User Response**

No action; information only.

- **816f040c-2012ffff : [PhysicalMemoryElementName] Enabled on Subsystem [MemoryElementName]. (DIMM 18)**

This message is for the use case when an implementation has detected that Memory has been Enabled.

May also be shown as 816f040c2012ffff or 0x816f040c2012ffff

**Severity**

Info

**Serviceable**

No

**Automatically notify support**

No

**Alert Category**

System - Other

**SNMP Trap ID**

**CIM Information**

Prefix: PLAT ID: 0130

**User Response**

No action; information only.

- **816f040c-2013ffff : [PhysicalMemoryElementName] Enabled on Subsystem [MemoryElementName]. (DIMM 19)**

This message is for the use case when an implementation has detected that Memory has been Enabled.

May also be shown as 816f040c2013ffff or 0x816f040c2013ffff

**Severity**

Info

**Serviceable**

No

**Automatically notify support**

No

**Alert Category**

System - Other

**SNMP Trap ID**

**CIM Information**

Prefix: PLAT ID: 0130

**User Response**

No action; information only.

- **816f040c-2014ffff : [PhysicalMemoryElementName] Enabled on Subsystem [MemoryElementName]. (DIMM 20)**

This message is for the use case when an implementation has detected that Memory has been Enabled.

May also be shown as 816f040c2014ffff or 0x816f040c2014ffff

**Severity**

Info

**Serviceable**

No

**Automatically notify support**

No

**Alert Category**

System - Other

**SNMP Trap ID****CIM Information**

Prefix: PLAT ID: 0130

**User Response**

No action; information only.

- **816f040c-2015ffff : [PhysicalMemoryElementName] Enabled on Subsystem [MemoryElementName]. (DIMM 21)**

This message is for the use case when an implementation has detected that Memory has been Enabled.

May also be shown as 816f040c2015ffff or 0x816f040c2015ffff

**Severity**

Info

**Serviceable**

No

**Automatically notify support**

No

**Alert Category**

System - Other

**SNMP Trap ID****CIM Information**

Prefix: PLAT ID: 0130

**User Response**

No action; information only.

- **816f040c-2016ffff : [PhysicalMemoryElementName] Enabled on Subsystem [MemoryElementName]. (DIMM 22)**

This message is for the use case when an implementation has detected that Memory has been Enabled.

May also be shown as 816f040c2016ffff or 0x816f040c2016ffff

**Severity**

Info

**Serviceable**

No

**Automatically notify support**

No

**Alert Category**

System - Other

**SNMP Trap ID****CIM Information**

Prefix: PLAT ID: 0130

**User Response**

No action; information only.

- **816f040c-2017ffff : [PhysicalMemoryElementName] Enabled on Subsystem [MemoryElementName]. (DIMM 23)**

This message is for the use case when an implementation has detected that Memory has been Enabled.

May also be shown as 816f040c2017ffff or 0x816f040c2017ffff

**Severity**

Info

**Serviceable**

No

**Automatically notify support**

No

**Alert Category**

System - Other

**SNMP Trap ID****CIM Information**

Prefix: PLAT ID: 0130

**User Response**

No action; information only.

- **816f040c-2018ffff : [PhysicalMemoryElementName] Enabled on Subsystem [MemoryElementName]. (DIMM 24)**

This message is for the use case when an implementation has detected that Memory has been Enabled.

May also be shown as 816f040c2018ffff or 0x816f040c2018ffff

**Severity**

Info

**Serviceable**

No

**Automatically notify support**

No

**Alert Category**

System - Other

**SNMP Trap ID**

**CIM Information**

Prefix: PLAT ID: 0130

**User Response**

No action; information only.

- **816f040c-2581ffff : [PhysicalMemoryElementName] Enabled on Subsystem [MemoryElementName]. (All DIMMS)**

This message is for the use case when an implementation has detected that Memory has been Enabled.

May also be shown as 816f040c2581ffff or 0x816f040c2581ffff

**Severity**

Info

**Serviceable**

No

**Automatically notify support**

No

**Alert Category**

System - Other

**SNMP Trap ID****CIM Information**

Prefix: PLAT ID: 0130

**User Response**

No action; information only. One of the DIMMs :

- **816f0413-2582ffff : A PCI PERR recovery has occurred on system [ComputerSystemElementName]. (PCIs)**

This message is for the use case when an implementation has detected a PCI PERR recovered.

May also be shown as 816f04132582ffff or 0x816f04132582ffff

**Severity**

Info

**Serviceable**

No

**Automatically notify support**

No

**Alert Category**

Critical - Other

**SNMP Trap ID**

50

**CIM Information**

Prefix: PLAT ID: 0233

**User Response**

No action; information only.

- **816f0507-0301ffff : [ProcessorElementName] has Recovered from a Configuration Mismatch. (CPU 1)**

This message is for the use case when an implementation has Recovered from a Processor Configuration Mismatch.

May also be shown as 816f05070301ffff or 0x816f05070301ffff

**Severity**

Info

**Serviceable**

No

**Automatically notify support**

No

**Alert Category**

Critical - CPU

**SNMP Trap ID**

40

**CIM Information**

**Prefix: PLAT ID:** 0063

**User Response**

No action; information only.

- **816f0507-0302ffff : [ProcessorElementName] has Recovered from a Configuration Mismatch. (CPU 2)**

This message is for the use case when an implementation has Recovered from a Processor Configuration Mismatch.

May also be shown as 816f05070302ffff or 0x816f05070302ffff

**Severity**

Info

**Serviceable**

No

**Automatically notify support**

No

**Alert Category**

Critical - CPU

**SNMP Trap ID**

40

**CIM Information**

**Prefix: PLAT ID:** 0063

**User Response**

No action; information only.

- **816f0507-2584ffff : [ProcessorElementName] has Recovered from a Configuration Mismatch. (All CPUs)**

This message is for the use case when an implementation has Recovered from a Processor Configuration Mismatch.

May also be shown as 816f05072584ffff or 0x816f05072584ffff

**Severity**

Info

**Serviceable**

No



**Automatically notify support**

No

**Alert Category**

Critical - CPU

**SNMP Trap ID**

40

**CIM Information**

Prefix: PLAT ID: 0063

**User Response**

No action; information only. One of the CPUs :

- **816f050c-2001ffff : Memory Logging Limit Removed for [PhysicalMemoryElementName] on Subsystem [MemoryElementName]. (DIMM 1)**

This message is for the use case when an implementation has detected that the Memory Logging Limit has been Removed.

May also be shown as 816f050c2001ffff or 0x816f050c2001ffff

**Severity**

Info

**Serviceable**

No

**Automatically notify support**

No

**Alert Category**

Warning - Memory

**SNMP Trap ID**

43

**CIM Information**

Prefix: PLAT ID: 0145

**User Response**

No action; information only.

- **816f050c-2002ffff : Memory Logging Limit Removed for [PhysicalMemoryElementName] on Subsystem [MemoryElementName]. (DIMM 2)**

This message is for the use case when an implementation has detected that the Memory Logging Limit has been Removed.

May also be shown as 816f050c2002ffff or 0x816f050c2002ffff

**Severity**

Info

**Serviceable**

No

**Automatically notify support**

No

**Alert Category**

Warning - Memory

**SNMP Trap ID**

43

**CIM Information**

Prefix: PLAT ID: 0145

**User Response**

No action; information only.

- **816f050c-2003ffff : Memory Logging Limit Removed for [PhysicalMemoryElementName] on Subsystem [MemoryElementName]. (DIMM 3)**

This message is for the use case when an implementation has detected that the Memory Logging Limit has been Removed.

May also be shown as 816f050c2003ffff or 0x816f050c2003ffff

**Severity**

Info

**Serviceable**

No

**Automatically notify support**

No

**Alert Category**

Warning - Memory

**SNMP Trap ID**

43

**CIM Information**

Prefix: PLAT ID: 0145

**User Response**

No action; information only.

- **816f050c-2004ffff : Memory Logging Limit Removed for [PhysicalMemoryElementName] on Subsystem [MemoryElementName]. (DIMM 4)**

This message is for the use case when an implementation has detected that the Memory Logging Limit has been Removed.

May also be shown as 816f050c2004ffff or 0x816f050c2004ffff

**Severity**

Info

**Serviceable**

No

**Automatically notify support**

No

**Alert Category**

Warning - Memory

**SNMP Trap ID**

43

**CIM Information**

Prefix: PLAT ID: 0145

**User Response**

No action; information only.

- **816f050c-2005ffff : Memory Logging Limit Removed for [PhysicalMemoryElementName] on Subsystem [MemoryElementName]. (DIMM 5)**

This message is for the use case when an implementation has detected that the Memory Logging Limit has been Removed.

May also be shown as 816f050c2005ffff or 0x816f050c2005ffff

**Severity**

Info

**Serviceable**

No

**Automatically notify support**

No

**Alert Category**

Warning - Memory

**SNMP Trap ID**

43

**CIM Information**

Prefix: PLAT ID: 0145

**User Response**

No action; information only.

- **816f050c-2006ffff : Memory Logging Limit Removed for [PhysicalMemoryElementName] on Subsystem [MemoryElementName]. (DIMM 6)**

This message is for the use case when an implementation has detected that the Memory Logging Limit has been Removed.

May also be shown as 816f050c2006ffff or 0x816f050c2006ffff

**Severity**

Info

**Serviceable**

No

**Automatically notify support**

No

**Alert Category**

Warning - Memory

**SNMP Trap ID**

43

**CIM Information**

Prefix: PLAT ID: 0145

**User Response**

No action; information only.

- **816f050c-2007ffff : Memory Logging Limit Removed for [PhysicalMemoryElementName] on Subsystem [MemoryElementName]. (DIMM 7)**

This message is for the use case when an implementation has detected that the Memory Logging Limit has been Removed.

May also be shown as 816f050c2007ffff or 0x816f050c2007ffff

**Severity**

Info

**Serviceable**

No

**Automatically notify support**

No

**Alert Category**

Warning - Memory

**SNMP Trap ID**

43

**CIM Information**

Prefix: PLAT ID: 0145

**User Response**

No action; information only.

- **816f050c-2008ffff : Memory Logging Limit Removed for [PhysicalMemoryElementName] on Subsystem [MemoryElementName]. (DIMM 8)**

This message is for the use case when an implementation has detected that the Memory Logging Limit has been Removed.

May also be shown as 816f050c2008ffff or 0x816f050c2008ffff

**Severity**

Info

**Serviceable**

No

**Automatically notify support**

No

**Alert Category**

Warning - Memory

**SNMP Trap ID**

43

**CIM Information**

Prefix: PLAT ID: 0145

**User Response**

No action; information only.

- **816f050c-2009ffff : Memory Logging Limit Removed for [PhysicalMemoryElementName] on Subsystem [MemoryElementName]. (DIMM 9)**

This message is for the use case when an implementation has detected that the Memory Logging Limit has been Removed.

May also be shown as 816f050c2009ffff or 0x816f050c2009ffff

**Severity**

Info

**Serviceable**

No

**Automatically notify support**

No

**Alert Category**

Warning - Memory

**SNMP Trap ID**

**CIM Information**

Prefix: PLAT ID: 0145

**User Response**

No action; information only.

- **816f050c-200affff : Memory Logging Limit Removed for [PhysicalMemoryElementName] on Subsystem [MemoryElementName]. (DIMM 10)**

This message is for the use case when an implementation has detected that the Memory Logging Limit has been Removed.

May also be shown as 816f050c200affff or 0x816f050c200affff

**Severity**

Info

**Serviceable**

No

**Automatically notify support**

No

**Alert Category**

Warning - Memory

**SNMP Trap ID**

43

**CIM Information**

Prefix: PLAT ID: 0145

**User Response**

No action; information only.

- **816f050c-200bffff : Memory Logging Limit Removed for [PhysicalMemoryElementName] on Subsystem [MemoryElementName]. (DIMM 11)**

This message is for the use case when an implementation has detected that the Memory Logging Limit has been Removed.

May also be shown as 816f050c200bffff or 0x816f050c200bffff

**Severity**

Info

**Serviceable**

No

**Automatically notify support**

No

**Alert Category**

Warning - Memory

**SNMP Trap ID**

43

**CIM Information**

Prefix: PLAT ID: 0145

**User Response**

No action; information only.

- **816f050c-200cffff : Memory Logging Limit Removed for [PhysicalMemoryElementName] on Subsystem [MemoryElementName]. (DIMM 12)**

This message is for the use case when an implementation has detected that the Memory Logging Limit has been Removed.

May also be shown as 816f050c200cffff or 0x816f050c200cffff

**Severity**

Info

**Serviceable**

No

**Automatically notify support**

No

**Alert Category**

Warning - Memory

**SNMP Trap ID**

43

**CIM Information**

Prefix: PLAT ID: 0145

**User Response**

No action; information only.

- **816f050c-200dffff : Memory Logging Limit Removed for [PhysicalMemoryElementName] on Subsystem [MemoryElementName]. (DIMM 13)**

This message is for the use case when an implementation has detected that the Memory Logging Limit has been Removed.

May also be shown as 816f050c200dffff or 0x816f050c200dffff

**Severity**

Info

**Serviceable**

No

**Automatically notify support**

No

**Alert Category**

Warning - Memory

**SNMP Trap ID**

43

**CIM Information**

Prefix: PLAT ID: 0145

**User Response**

No action; information only.

- **816f050c-200effff : Memory Logging Limit Removed for [PhysicalMemoryElementName] on Subsystem [MemoryElementName]. (DIMM 14)**

This message is for the use case when an implementation has detected that the Memory Logging Limit has been Removed.

May also be shown as 816f050c200effff or 0x816f050c200effff

**Severity**

Info

**Serviceable**

No

**Automatically notify support**

No

**Alert Category**

Warning - Memory

**SNMP Trap ID**

43

**CIM Information**

**Prefix: PLAT ID:** 0145

**User Response**

No action; information only.

- **816f050c-200ffff : Memory Logging Limit Removed for [PhysicalMemoryElementName] on Subsystem [MemoryElementName]. (DIMM 15)**

This message is for the use case when an implementation has detected that the Memory Logging Limit has been Removed.

May also be shown as 816f050c200ffff or 0x816f050c200ffff

**Severity**

Info

**Serviceable**

No

**Automatically notify support**

No

**Alert Category**

Warning - Memory

**SNMP Trap ID**

43

**CIM Information**

**Prefix: PLAT ID:** 0145

**User Response**

No action; information only.

- **816f050c-2010ffff : Memory Logging Limit Removed for [PhysicalMemoryElementName] on Subsystem [MemoryElementName]. (DIMM 16)**

This message is for the use case when an implementation has detected that the Memory Logging Limit has been Removed.

May also be shown as 816f050c2010ffff or 0x816f050c2010ffff

**Severity**

Info

**Serviceable**

No

**Automatically notify support**

No

**Alert Category**

Warning - Memory

**SNMP Trap ID**

43

**CIM Information**

**Prefix: PLAT ID:** 0145

**User Response**

No action; information only.

- **816f050c-2011ffff : Memory Logging Limit Removed for [PhysicalMemoryElementName] on Subsystem [MemoryElementName]. (DIMM 17)**

This message is for the use case when an implementation has detected that the Memory Logging Limit has been Removed.

May also be shown as 816f050c2011ffff or 0x816f050c2011ffff

**Severity**

Info

**Serviceable**

No

**Automatically notify support**

No

**Alert Category**

Warning - Memory

**SNMP Trap ID**

43

**CIM Information**

**Prefix: PLAT ID:** 0145

**User Response**

No action; information only.

- **816f050c-2012ffff : Memory Logging Limit Removed for [PhysicalMemoryElementName] on Subsystem [MemoryElementName]. (DIMM 18)**

This message is for the use case when an implementation has detected that the Memory Logging Limit has been Removed.

May also be shown as 816f050c2012ffff or 0x816f050c2012ffff

**Severity**

Info

**Serviceable**

No

**Automatically notify support**

No

**Alert Category**

Warning - Memory

**SNMP Trap ID**

43

**CIM Information**

**Prefix: PLAT ID:** 0145

**User Response**



No action; information only.

- **816f050c-2013ffff : Memory Logging Limit Removed for [PhysicalMemoryElementName] on Subsystem [MemoryElementName]. (DIMM 19)**

This message is for the use case when an implementation has detected that the Memory Logging Limit has been Removed.

May also be shown as 816f050c2013ffff or 0x816f050c2013ffff

**Severity**

Info

**Serviceable**

No

**Automatically notify support**

No

**Alert Category**

Warning - Memory

**SNMP Trap ID**

43

**CIM Information**

**Prefix: PLAT ID:** 0145

**User Response**

No action; information only.

- **816f050c-2014ffff : Memory Logging Limit Removed for [PhysicalMemoryElementName] on Subsystem [MemoryElementName]. (DIMM 20)**

This message is for the use case when an implementation has detected that the Memory Logging Limit has been Removed.

May also be shown as 816f050c2014ffff or 0x816f050c2014ffff

**Severity**

Info

**Serviceable**

No

**Automatically notify support**

No

**Alert Category**

Warning - Memory

**SNMP Trap ID**

43

**CIM Information**

**Prefix: PLAT ID:** 0145

**User Response**

No action; information only.

- **816f050c-2015ffff : Memory Logging Limit Removed for [PhysicalMemoryElementName] on Subsystem [MemoryElementName]. (DIMM 21)**

This message is for the use case when an implementation has detected that the Memory Logging Limit has been Removed.

May also be shown as 816f050c2015ffff or 0x816f050c2015ffff

**Severity**

Info

**Serviceable**

No

**Automatically notify support**

No

**Alert Category**

Warning - Memory

**SNMP Trap ID**

43

**CIM Information****Prefix: PLAT ID:** 0145**User Response**

No action; information only.

- **816f050c-2016ffff : Memory Logging Limit Removed for [PhysicalMemoryElementName] on Subsystem [MemoryElementName]. (DIMM 22)**

This message is for the use case when an implementation has detected that the Memory Logging Limit has been Removed.

May also be shown as 816f050c2016ffff or 0x816f050c2016ffff

**Severity**

Info

**Serviceable**

No

**Automatically notify support**

No

**Alert Category**

Warning - Memory

**SNMP Trap ID**

43

**CIM Information****Prefix: PLAT ID:** 0145**User Response**

No action; information only.

- **816f050c-2017ffff : Memory Logging Limit Removed for [PhysicalMemoryElementName] on Subsystem [MemoryElementName]. (DIMM 23)**

This message is for the use case when an implementation has detected that the Memory Logging Limit has been Removed.

May also be shown as 816f050c2017ffff or 0x816f050c2017ffff

**Severity**

Info

**Serviceable**

No

**Automatically notify support**

No

**Alert Category**

Warning - Memory

**SNMP Trap ID**

43

**CIM Information**

**Prefix:** PLAT ID: 0145

**User Response**

No action; information only.

- **816f050c-2018ffff : Memory Logging Limit Removed for [PhysicalMemoryElementName] on Subsystem [MemoryElementName]. (DIMM 24)**

This message is for the use case when an implementation has detected that the Memory Logging Limit has been Removed.

May also be shown as 816f050c2018ffff or 0x816f050c2018ffff

**Severity**

Info

**Serviceable**

No

**Automatically notify support**

No

**Alert Category**

Warning - Memory

**SNMP Trap ID**

43

**CIM Information**

**Prefix:** PLAT ID: 0145

**User Response**

No action; information only.

- **816f050c-2581ffff : Memory Logging Limit Removed for [PhysicalMemoryElementName] on Subsystem [MemoryElementName]. (All DIMMS)**

This message is for the use case when an implementation has detected that the Memory Logging Limit has been Removed.

May also be shown as 816f050c2581ffff or 0x816f050c2581ffff

**Severity**

Info

**Serviceable**

No

**Automatically notify support**

No

**Alert Category**

Warning - Memory

**SNMP Trap ID**

43

**CIM Information**

**Prefix:** PLAT ID: 0145

**User Response**

No action; information only. One of the DIMMs :

- **816f050d-0400ffff : Critical Array [ComputerSystemElementName] has deasserted. (Drive 0)**

This message is for the use case when an implementation has detected that an Critical Array has deasserted.

May also be shown as 816f050d0400ffff or 0x816f050d0400ffff

**Severity**

Info

**Serviceable**

No

**Automatically notify support**

No

**Alert Category**

Critical - Hard Disk drive

**SNMP Trap ID**

5

**CIM Information**

Prefix: PLAT ID: 0175

**User Response**

No action; information only.

- **816f050d-0401ffff : Critical Array [ComputerSystemElementName] has deasserted. (Drive 1)**

This message is for the use case when an implementation has detected that an Critical Array has deasserted.

May also be shown as 816f050d0401ffff or 0x816f050d0401ffff

**Severity**

Info

**Serviceable**

No

**Automatically notify support**

No

**Alert Category**

Critical - Hard Disk drive

**SNMP Trap ID**

5

**CIM Information**

Prefix: PLAT ID: 0175

**User Response**

No action; information only.

- **816f050d-0402ffff : Critical Array [ComputerSystemElementName] has deasserted. (Drive 2)**

This message is for the use case when an implementation has detected that an Critical Array has deasserted.

May also be shown as 816f050d0402ffff or 0x816f050d0402ffff

**Severity**

Info

**Serviceable**

No

**Automatically notify support**

No

**Alert Category**

Critical - Hard Disk drive

**SNMP Trap ID**

5

**CIM Information**

**Prefix:** PLAT ID: 0175

**User Response**

No action; information only.

- **816f050d-0403ffff : Critical Array [ComputerSystemElementName] has deasserted. (Drive 3)**

This message is for the use case when an implementation has detected that an Critical Array has deasserted.

May also be shown as 816f050d0403ffff or 0x816f050d0403ffff

**Severity**

Info

**Serviceable**

No

**Automatically notify support**

No

**Alert Category**

Critical - Hard Disk drive

**SNMP Trap ID**

5

**CIM Information**

**Prefix:** PLAT ID: 0175

**User Response**

No action; information only.

- **816f050d-0404ffff : Critical Array [ComputerSystemElementName] has deasserted. (Drive 4)**

This message is for the use case when an implementation has detected that an Critical Array has deasserted.

May also be shown as 816f050d0404ffff or 0x816f050d0404ffff

**Severity**

Info

**Serviceable**

No

**Automatically notify support**

No

**Alert Category**

Critical - Hard Disk drive

**SNMP Trap ID**

5

**CIM Information**

Prefix: PLAT ID: 0175

**User Response**

No action; information only.

- **816f050d-0405ffff : Critical Array [ComputerSystemElementName] has deasserted. (Drive 5)**

This message is for the use case when an implementation has detected that an Critical Array has deasserted.

May also be shown as 816f050d0405ffff or 0x816f050d0405ffff

**Severity**

Info

**Serviceable**

No

**Automatically notify support**

No

**Alert Category**

Critical - Hard Disk drive

**SNMP Trap ID**

5

**CIM Information**

Prefix: PLAT ID: 0175

**User Response**

No action; information only.

- **816f050d-0406ffff : Critical Array [ComputerSystemElementName] has deasserted. (Drive 6)**

This message is for the use case when an implementation has detected that an Critical Array has deasserted.

May also be shown as 816f050d0406ffff or 0x816f050d0406ffff

**Severity**

Info

**Serviceable**

No

**Automatically notify support**

No

**Alert Category**

Critical - Hard Disk drive

**SNMP Trap ID**

5

**CIM Information**

Prefix: PLAT ID: 0175

**User Response**

No action; information only.

- **816f050d-0407ffff : Critical Array [ComputerSystemElementName] has deasserted. (Drive 7)**

This message is for the use case when an implementation has detected that an Critical Array has deasserted.

May also be shown as 816f050d0407ffff or 0x816f050d0407ffff

**Severity**

Info

**Serviceable**

No

**Automatically notify support**

No

**Alert Category**

Critical - Hard Disk drive

**SNMP Trap ID**

5

**CIM Information****Prefix: PLAT ID:** 0175**User Response**

No action; information only.

- **816f050d-0408ffff : Critical Array [ComputerSystemElementName] has deasserted. (Drive 8)**

This message is for the use case when an implementation has detected that an Critical Array has deasserted.

May also be shown as 816f050d0408ffff or 0x816f050d0408ffff

**Severity**

Info

**Serviceable**

No

**Automatically notify support**

No

**Alert Category**

Critical - Hard Disk drive

**SNMP Trap ID**

5

**CIM Information****Prefix: PLAT ID:** 0175**User Response**

No action; information only.

- **816f050d-0409ffff : Critical Array [ComputerSystemElementName] has deasserted. (Drive 9)**

This message is for the use case when an implementation has detected that an Critical Array has deasserted.

May also be shown as 816f050d0409ffff or 0x816f050d0409ffff

**Severity**

Info

**Serviceable**

No

**Automatically notify support**

No

**Alert Category**

Critical - Hard Disk drive

**SNMP Trap ID**

5

**CIM Information**

Prefix: PLAT ID: 0175

**User Response**

No action; information only.

- **816f050d-040affff : Critical Array [ComputerSystemElementName] has deasserted. (Drive 10)**

This message is for the use case when an implementation has detected that an Critical Array has deasserted.

May also be shown as 816f050d040affff or 0x816f050d040affff

**Severity**

Info

**Serviceable**

No

**Automatically notify support**

No

**Alert Category**

Critical - Hard Disk drive

**SNMP Trap ID**

5

**CIM Information**

Prefix: PLAT ID: 0175

**User Response**

No action; information only.

- **816f050d-040bffff : Critical Array [ComputerSystemElementName] has deasserted. (Drive 11)**

This message is for the use case when an implementation has detected that an Critical Array has deasserted.

May also be shown as 816f050d040bffff or 0x816f050d040bffff

**Severity**

Info

**Serviceable**

No

**Automatically notify support**

No

**Alert Category**

Critical - Hard Disk drive

**SNMP Trap ID**

5

**CIM Information**

Prefix: PLAT ID: 0175

**User Response**

No action; information only.

- **816f050d-040cffff : Critical Array [ComputerSystemElementName] has deasserted. (Drive 12)**



This message is for the use case when an implementation has detected that an Critical Array has deasserted.

May also be shown as 816f050d040cffff or 0x816f050d040cffff

**Severity**

Info

**Serviceable**

No

**Automatically notify support**

No

**Alert Category**

Critical - Hard Disk drive

**SNMP Trap ID**

5

**CIM Information**

Prefix: PLAT ID: 0175

**User Response**

No action; information only.

- **816f050d-040dffff : Critical Array [ComputerSystemElementName] has deasserted. (Drive 13)**

This message is for the use case when an implementation has detected that an Critical Array has deasserted.

May also be shown as 816f050d040dffff or 0x816f050d040dffff

**Severity**

Info

**Serviceable**

No

**Automatically notify support**

No

**Alert Category**

Critical - Hard Disk drive

**SNMP Trap ID**

5

**CIM Information**

Prefix: PLAT ID: 0175

**User Response**

No action; information only.

- **816f050d-040effff : Critical Array [ComputerSystemElementName] has deasserted. (Drive 14)**

This message is for the use case when an implementation has detected that an Critical Array has deasserted.

May also be shown as 816f050d040effff or 0x816f050d040effff

**Severity**

Info

**Serviceable**

No

**Automatically notify support**

No

**Alert Category**

Critical - Hard Disk drive

**SNMP Trap ID**

5

**CIM Information**

Prefix: PLAT ID: 0175

**User Response**

No action; information only.

- **816f050d-040ffff : Critical Array [ComputerSystemElementName] has deasserted. (Drive 15)**

This message is for the use case when an implementation has detected that an Critical Array has deasserted.

May also be shown as 816f050d040ffff or 0x816f050d040ffff

**Severity**

Info

**Serviceable**

No

**Automatically notify support**

No

**Alert Category**

Critical - Hard Disk drive

**SNMP Trap ID**

5

**CIM Information**

Prefix: PLAT ID: 0175

**User Response**

No action; information only.

- **816f050d-0410ffff : Critical Array [ComputerSystemElementName] has deasserted. (Drive 16)**

This message is for the use case when an implementation has detected that an Critical Array has deasserted.

May also be shown as 816f050d0410ffff or 0x816f050d0410ffff

**Severity**

Info

**Serviceable**

No

**Automatically notify support**

No

**Alert Category**

Critical - Hard Disk drive

**SNMP Trap ID**

5

**CIM Information**

Prefix: PLAT ID: 0175

**User Response**

No action; information only.

- **816f050d-0411ffff : Critical Array [ComputerSystemElementName] has deasserted. (Drive 17)**

This message is for the use case when an implementation has detected that an Critical Array has deasserted.

May also be shown as 816f050d0411ffff or 0x816f050d0411ffff

**Severity**

Info

**Serviceable**

No

**Automatically notify support**

No

**Alert Category**

Critical - Hard Disk drive

**SNMP Trap ID**

5

**CIM Information**

Prefix: PLAT ID: 0175

**User Response**

No action; information only.

- **816f050d-0412ffff : Critical Array [ComputerSystemElementName] has deasserted. (Drive 18)**

This message is for the use case when an implementation has detected that an Critical Array has deasserted.

May also be shown as 816f050d0412ffff or 0x816f050d0412ffff

**Severity**

Info

**Serviceable**

No

**Automatically notify support**

No

**Alert Category**

Critical - Hard Disk drive

**SNMP Trap ID**

5

**CIM Information**

Prefix: PLAT ID: 0175

**User Response**

No action; information only.

- **816f050d-0413ffff : Critical Array [ComputerSystemElementName] has deasserted. (Drive 19)**

This message is for the use case when an implementation has detected that an Critical Array has deasserted.

May also be shown as 816f050d0413ffff or 0x816f050d0413ffff

**Severity**

Info

**Serviceable**

No

**Automatically notify support**

No

**Alert Category**

Critical - Hard Disk drive

**SNMP Trap ID**

5

**CIM Information**

Prefix: PLAT ID: 0175

**User Response**

No action; information only.

- **816f050d-0414ffff : Critical Array [ComputerSystemElementName] has deasserted. (Drive 20)**

This message is for the use case when an implementation has detected that an Critical Array has deasserted.

May also be shown as 816f050d0414ffff or 0x816f050d0414ffff

**Severity**

Info

**Serviceable**

No

**Automatically notify support**

No

**Alert Category**

Critical - Hard Disk drive

**SNMP Trap ID**

5

**CIM Information**

Prefix: PLAT ID: 0175

**User Response**

No action; information only.

- **816f050d-0415ffff : Critical Array [ComputerSystemElementName] has deasserted. (Drive 21)**

This message is for the use case when an implementation has detected that an Critical Array has deasserted.

May also be shown as 816f050d0415ffff or 0x816f050d0415ffff

**Severity**

Info

**Serviceable**

No

**Automatically notify support**

No

**Alert Category**

Critical - Hard Disk drive

**SNMP Trap ID**

5

**CIM Information**

Prefix: PLAT ID: 0175

**User Response**

No action; information only.

- **816f050d-0416ffff : Critical Array [ComputerSystemElementName] has deasserted. (Drive 22)**

This message is for the use case when an implementation has detected that an Critical Array has deasserted.

May also be shown as 816f050d0416ffff or 0x816f050d0416ffff

**Severity**

Info

**Serviceable**

No

**Automatically notify support**

No

**Alert Category**

Critical - Hard Disk drive

**SNMP Trap ID**

5

**CIM Information**

Prefix: PLAT ID: 0175

**User Response**

No action; information only.

- **816f050d-0417ffff : Critical Array [ComputerSystemElementName] has deasserted. (Drive 23)**

This message is for the use case when an implementation has detected that an Critical Array has deasserted.

May also be shown as 816f050d0417ffff or 0x816f050d0417ffff

**Severity**

Info

**Serviceable**

No

**Automatically notify support**

No

**Alert Category**

Critical - Hard Disk drive

**SNMP Trap ID**

5

**CIM Information**

Prefix: PLAT ID: 0175

**User Response**

No action; information only.

- **816f050d-0418ffff : Critical Array [ComputerSystemElementName] has deasserted. (Drive 24)**

This message is for the use case when an implementation has detected that an Critical Array has deasserted.

May also be shown as 816f050d0418ffff or 0x816f050d0418ffff

**Severity**

Info

**Serviceable**

No

**Automatically notify support**

No

**Alert Category**

Critical - Hard Disk drive

**SNMP Trap ID**

5

**CIM Information**

Prefix: PLAT ID: 0175

**User Response**

No action; information only.

- **816f050d-0419ffff : Critical Array [ComputerSystemElementName] has deasserted. (Drive 25)**

This message is for the use case when an implementation has detected that an Critical Array has deasserted.

May also be shown as 816f050d0419ffff or 0x816f050d0419ffff

**Severity**

Info

**Serviceable**

No

**Automatically notify support**

No

**Alert Category**

Critical - Hard Disk drive

**SNMP Trap ID**

5

**CIM Information**

Prefix: PLAT ID: 0175

**User Response**

No action; information only.

- **816f050d-041affff : Critical Array [ComputerSystemElementName] has deasserted. (Drive 26)**

This message is for the use case when an implementation has detected that an Critical Array has deasserted.

May also be shown as 816f050d041affff or 0x816f050d041affff

**Severity**

Info

**Serviceable**

No

**Automatically notify support**

No

**Alert Category**

Critical - Hard Disk drive

**SNMP Trap ID**

5

**CIM Information****Prefix:** PLAT ID: 0175**User Response**

No action; information only.

- **816f050d-041bffff : Critical Array [ComputerSystemElementName] has deasserted. (Drive 27)**

This message is for the use case when an implementation has detected that an Critical Array has deasserted.

May also be shown as 816f050d041bffff or 0x816f050d041bffff

**Severity**

Info

**Serviceable**

No

**Automatically notify support**

No

**Alert Category**

Critical - Hard Disk drive

**SNMP Trap ID**

5

**CIM Information****Prefix:** PLAT ID: 0175**User Response**

No action; information only.

- **816f050d-041cffff : Critical Array [ComputerSystemElementName] has deasserted. (Drive 28)**

This message is for the use case when an implementation has detected that an Critical Array has deasserted.

May also be shown as 816f050d041cffff or 0x816f050d041cffff

**Severity**

Info

**Serviceable**

No

**Automatically notify support**

No

**Alert Category**

Critical - Hard Disk drive

**SNMP Trap ID**

5

**CIM Information****Prefix:** PLAT ID: 0175**User Response**

No action; information only.

- **816f050d-041dffff : Critical Array [ComputerSystemElementName] has deasserted. (Drive 29)**

This message is for the use case when an implementation has detected that an Critical Array has deasserted.

May also be shown as 816f050d041dffff or 0x816f050d041dffff

**Severity**

Info

**Serviceable**

No

**Automatically notify support**

No

**Alert Category**

Critical - Hard Disk drive

**SNMP Trap ID**

5

**CIM Information**

Prefix: PLAT ID: 0175

**User Response**

No action; information only.

- **816f050d-041effff : Critical Array [ComputerSystemElementName] has deasserted. (Drive 30)**

This message is for the use case when an implementation has detected that an Critical Array has deasserted.

May also be shown as 816f050d041effff or 0x816f050d041effff

**Severity**

Info

**Serviceable**

No

**Automatically notify support**

No

**Alert Category**

Critical - Hard Disk drive

**SNMP Trap ID**

5

**CIM Information**

Prefix: PLAT ID: 0175

**User Response**

No action; information only.

- **816f050d-041fffff : Critical Array [ComputerSystemElementName] has deasserted. (Drive 31)**

This message is for the use case when an implementation has detected that an Critical Array has deasserted.

May also be shown as 816f050d041fffff or 0x816f050d041fffff

**Severity**

Info

**Serviceable**

No



**Automatically notify support**

No

**Alert Category**

Critical - Hard Disk drive

**SNMP Trap ID**

5

**CIM Information**

Prefix: PLAT ID: 0175

**User Response**

No action; information only.

- **816f050d-0420ffff : Critical Array [ComputerSystemElementName] has deasserted. (Ext Drive)**

This message is for the use case when an implementation has detected that an Critical Array has deasserted.

May also be shown as 816f050d0420ffff or 0x816f050d0420ffff

**Severity**

Info

**Serviceable**

No

**Automatically notify support**

No

**Alert Category**

Critical - Hard Disk drive

**SNMP Trap ID**

5

**CIM Information**

Prefix: PLAT ID: 0175

**User Response**

No action; information only.

- **816f0513-2582ffff : A PCI SERR on system [ComputerSystemElementName] has deasserted. (PCIs)**

This message is for the use case when an implementation has detected a PCI SERR deassertion.

May also be shown as 816f05132582ffff or 0x816f05132582ffff

**Severity**

Info

**Serviceable**

No

**Automatically notify support**

No

**Alert Category**

Critical - Other

**SNMP Trap ID**

50

**CIM Information**

Prefix: PLAT ID: 0235

**User Response**

No action; information only.

- **816f0607-0301ffff : An SM BIOS Uncorrectable CPU complex error for [ProcessorElementName] has deasserted. (CPU 1)**

This message is for the use case when an SM BIOS Uncorrectable CPU complex error has deasserted. May also be shown as 816f06070301ffff or 0x816f06070301ffff

**Severity**

Info

**Serviceable**

No

**Automatically notify support**

No

**Alert Category**

Critical - CPU

**SNMP Trap ID**

40

**CIM Information**

Prefix: PLAT ID: 0817

**User Response**

No action; information only.

- **816f0607-0302ffff : An SM BIOS Uncorrectable CPU complex error for [ProcessorElementName] has deasserted. (CPU 2)**

This message is for the use case when an SM BIOS Uncorrectable CPU complex error has deasserted. May also be shown as 816f06070302ffff or 0x816f06070302ffff

**Severity**

Info

**Serviceable**

No

**Automatically notify support**

No

**Alert Category**

Critical - CPU

**SNMP Trap ID**

40

**CIM Information**

Prefix: PLAT ID: 0817

**User Response**

No action; information only.

- **816f0607-2584ffff : An SM BIOS Uncorrectable CPU complex error for [ProcessorElementName] has deasserted. (All CPUs)**

This message is for the use case when an SM BIOS Uncorrectable CPU complex error has deasserted. May also be shown as 816f06072584ffff or 0x816f06072584ffff

**Severity**

Info

**Serviceable**

No

**Automatically notify support**

No

**Alert Category**

Critical - CPU

**SNMP Trap ID**

40

**CIM Information**

Prefix: PLAT ID: 0817

**User Response**

No action; information only. One of the CPUs :

- **816f0608-1301ffff : [PowerSupplyElementName] Configuration is OK. (PS Configuration)**

This message is for the use case when an implementation when a Power Supply configuration is OK.

May also be shown as 816f06081301ffff or 0x816f06081301ffff

**Severity**

Info

**Serviceable**

No

**Automatically notify support**

No

**Alert Category**

Critical - Power

**SNMP Trap ID**

4

**CIM Information**

Prefix: PLAT ID: 0105

**User Response**

No action; information only.

- **816f060d-0400ffff : Array in system [ComputerSystemElementName] has been restored. (Drive 0)**

This message is for the use case when an implementation has detected that a Failed Array has been Restored.

May also be shown as 816f060d0400ffff or 0x816f060d0400ffff

**Severity**

Info

**Serviceable**

No

**Automatically notify support**

No

**Alert Category**

Critical - Hard Disk drive

**SNMP Trap ID**

5

**CIM Information**

**Prefix: PLAT ID:** 0177

**User Response**

No action; information only.

- **816f060d-0401ffff : Array in system [ComputerSystemElementName] has been restored. (Drive 1)**

This message is for the use case when an implementation has detected that a Failed Array has been Restored.

May also be shown as 816f060d0401ffff or 0x816f060d0401ffff

**Severity**

Info

**Serviceable**

No

**Automatically notify support**

No

**Alert Category**

Critical - Hard Disk drive

**SNMP Trap ID**

5

**CIM Information**

**Prefix: PLAT ID:** 0177

**User Response**

No action; information only.

- **816f060d-0402ffff : Array in system [ComputerSystemElementName] has been restored. (Drive 2)**

This message is for the use case when an implementation has detected that a Failed Array has been Restored.

May also be shown as 816f060d0402ffff or 0x816f060d0402ffff

**Severity**

Info

**Serviceable**

No

**Automatically notify support**

No

**Alert Category**

Critical - Hard Disk drive

**SNMP Trap ID**

5

**CIM Information**

**Prefix: PLAT ID:** 0177

**User Response**

No action; information only.

- **816f060d-0403ffff : Array in system [ComputerSystemElementName] has been restored. (Drive 3)**

This message is for the use case when an implementation has detected that a Failed Array has been Restored.

May also be shown as 816f060d0403ffff or 0x816f060d0403ffff

**Severity**

Info

**Serviceable**

No

**Automatically notify support**

No

**Alert Category**

Critical - Hard Disk drive

**SNMP Trap ID**

5

**CIM Information****Prefix:** PLAT ID: 0177**User Response**

No action; information only.

- **816f060d-0404ffff : Array in system [ComputerSystemElementName] has been restored. (Drive 4)**

This message is for the use case when an implementation has detected that a Failed Array has been Restored.

May also be shown as 816f060d0404ffff or 0x816f060d0404ffff

**Severity**

Info

**Serviceable**

No

**Automatically notify support**

No

**Alert Category**

Critical - Hard Disk drive

**SNMP Trap ID**

5

**CIM Information****Prefix:** PLAT ID: 0177**User Response**

No action; information only.

- **816f060d-0405ffff : Array in system [ComputerSystemElementName] has been restored. (Drive 5)**

This message is for the use case when an implementation has detected that a Failed Array has been Restored.

May also be shown as 816f060d0405ffff or 0x816f060d0405ffff

**Severity**

Info

**Serviceable**

No

**Automatically notify support**

No

**Alert Category**

Critical - Hard Disk drive

**SNMP Trap ID**

5

**CIM Information**

Prefix: PLAT ID: 0177

**User Response**

No action; information only.

- **816f060d-0406ffff : Array in system [ComputerSystemElementName] has been restored. (Drive 6)**

This message is for the use case when an implementation has detected that a Failed Array has been Restored.

May also be shown as 816f060d0406ffff or 0x816f060d0406ffff

**Severity**

Info

**Serviceable**

No

**Automatically notify support**

No

**Alert Category**

Critical - Hard Disk drive

**SNMP Trap ID**

5

**CIM Information**

Prefix: PLAT ID: 0177

**User Response**

No action; information only.

- **816f060d-0407ffff : Array in system [ComputerSystemElementName] has been restored. (Drive 7)**

This message is for the use case when an implementation has detected that a Failed Array has been Restored.

May also be shown as 816f060d0407ffff or 0x816f060d0407ffff

**Severity**

Info

**Serviceable**

No

**Automatically notify support**

No

**Alert Category**

Critical - Hard Disk drive

**SNMP Trap ID**

5

**CIM Information**

Prefix: PLAT ID: 0177

**User Response**

No action; information only.

- **816f060d-0408ffff : Array in system [ComputerSystemElementName] has been restored. (Drive 8)**

This message is for the use case when an implementation has detected that a Failed Array has been Restored.

May also be shown as 816f060d0408ffff or 0x816f060d0408ffff

**Severity**

Info

**Serviceable**

No

**Automatically notify support**

No

**Alert Category**

Critical - Hard Disk drive

**SNMP Trap ID**

5

**CIM Information**

Prefix: PLAT ID: 0177

**User Response**

No action; information only.

- **816f060d-0409ffff : Array in system [ComputerSystemElementName] has been restored. (Drive 9)**

This message is for the use case when an implementation has detected that a Failed Array has been Restored.

May also be shown as 816f060d0409ffff or 0x816f060d0409ffff

**Severity**

Info

**Serviceable**

No

**Automatically notify support**

No

**Alert Category**

Critical - Hard Disk drive

**SNMP Trap ID**

5

**CIM Information**

Prefix: PLAT ID: 0177

**User Response**

No action; information only.

- **816f060d-040affff : Array in system [ComputerSystemElementName] has been restored. (Drive 10)**

This message is for the use case when an implementation has detected that a Failed Array has been Restored.

May also be shown as 816f060d040affff or 0x816f060d040affff

**Severity**

Info

**Serviceable**

No

**Automatically notify support**

No

**Alert Category**

Critical - Hard Disk drive

**SNMP Trap ID**

5

**CIM Information**

Prefix: PLAT ID: 0177

**User Response**

No action; information only.

- **816f060d-040bffff : Array in system [ComputerSystemElementName] has been restored. (Drive 11)**

This message is for the use case when an implementation has detected that a Failed Array has been Restored.

May also be shown as 816f060d040bffff or 0x816f060d040bffff

**Severity**

Info

**Serviceable**

No

**Automatically notify support**

No

**Alert Category**

Critical - Hard Disk drive

**SNMP Trap ID**

5

**CIM Information**

Prefix: PLAT ID: 0177

**User Response**

No action; information only.

- **816f060d-040cffff : Array in system [ComputerSystemElementName] has been restored. (Drive 12)**

This message is for the use case when an implementation has detected that a Failed Array has been Restored.

May also be shown as 816f060d040cffff or 0x816f060d040cffff

**Severity**

Info

**Serviceable**

No

**Automatically notify support**

No

**Alert Category**

Critical - Hard Disk drive

**SNMP Trap ID**

5

**CIM Information**

Prefix: PLAT ID: 0177



**User Response**

No action; information only.

- **816f060d-040dffff : Array in system [ComputerSystemElementName] has been restored. (Drive 13)**

This message is for the use case when an implementation has detected that a Failed Array has been Restored.

May also be shown as 816f060d040dffff or 0x816f060d040dffff

**Severity**

Info

**Serviceable**

No

**Automatically notify support**

No

**Alert Category**

Critical - Hard Disk drive

**SNMP Trap ID**

5

**CIM Information**

Prefix: PLAT ID: 0177

**User Response**

No action; information only.

- **816f060d-040effff : Array in system [ComputerSystemElementName] has been restored. (Drive 14)**

This message is for the use case when an implementation has detected that a Failed Array has been Restored.

May also be shown as 816f060d040effff or 0x816f060d040effff

**Severity**

Info

**Serviceable**

No

**Automatically notify support**

No

**Alert Category**

Critical - Hard Disk drive

**SNMP Trap ID**

5

**CIM Information**

Prefix: PLAT ID: 0177

**User Response**

No action; information only.

- **816f060d-040fffff : Array in system [ComputerSystemElementName] has been restored. (Drive 15)**

This message is for the use case when an implementation has detected that a Failed Array has been Restored.

May also be shown as 816f060d040fffff or 0x816f060d040fffff

**Severity**

Info

**Serviceable**

No

**Automatically notify support**

No

**Alert Category**

Critical - Hard Disk drive

**SNMP Trap ID**

5

**CIM Information**

Prefix: PLAT ID: 0177

**User Response**

No action; information only.

- **816f060d-0410ffff : Array in system [ComputerSystemElementName] has been restored. (Drive 16)**

This message is for the use case when an implementation has detected that a Failed Array has been Restored.

May also be shown as 816f060d0410ffff or 0x816f060d0410ffff

**Severity**

Info

**Serviceable**

No

**Automatically notify support**

No

**Alert Category**

Critical - Hard Disk drive

**SNMP Trap ID**

5

**CIM Information**

Prefix: PLAT ID: 0177

**User Response**

No action; information only.

- **816f060d-0411ffff : Array in system [ComputerSystemElementName] has been restored. (Drive 17)**

This message is for the use case when an implementation has detected that a Failed Array has been Restored.

May also be shown as 816f060d0411ffff or 0x816f060d0411ffff

**Severity**

Info

**Serviceable**

No

**Automatically notify support**

No

**Alert Category**

Critical - Hard Disk drive

**SNMP Trap ID**

5

**CIM Information**

Prefix: PLAT ID: 0177

**User Response**

No action; information only.

- **816f060d-0412ffff : Array in system [ComputerSystemElementName] has been restored. (Drive 18)**

This message is for the use case when an implementation has detected that a Failed Array has been Restored.

May also be shown as 816f060d0412ffff or 0x816f060d0412ffff

**Severity**

Info

**Serviceable**

No

**Automatically notify support**

No

**Alert Category**

Critical - Hard Disk drive

**SNMP Trap ID**

5

**CIM Information**

Prefix: PLAT ID: 0177

**User Response**

No action; information only.

- **816f060d-0413ffff : Array in system [ComputerSystemElementName] has been restored. (Drive 19)**

This message is for the use case when an implementation has detected that a Failed Array has been Restored.

May also be shown as 816f060d0413ffff or 0x816f060d0413ffff

**Severity**

Info

**Serviceable**

No

**Automatically notify support**

No

**Alert Category**

Critical - Hard Disk drive

**SNMP Trap ID**

5

**CIM Information**

Prefix: PLAT ID: 0177

**User Response**

No action; information only.

- **816f060d-0414ffff : Array in system [ComputerSystemElementName] has been restored. (Drive 20)**

This message is for the use case when an implementation has detected that a Failed Array has been Restored.

May also be shown as 816f060d0414ffff or 0x816f060d0414ffff

**Severity**

Info

**Serviceable**

No

**Automatically notify support**

No

**Alert Category**

Critical - Hard Disk drive

**SNMP Trap ID**

5

**CIM Information****Prefix: PLAT ID:** 0177**User Response**

No action; information only.

- **816f060d-0415ffff : Array in system [ComputerSystemElementName] has been restored. (Drive 21)**

This message is for the use case when an implementation has detected that a Failed Array has been Restored.

May also be shown as 816f060d0415ffff or 0x816f060d0415ffff

**Severity**

Info

**Serviceable**

No

**Automatically notify support**

No

**Alert Category**

Critical - Hard Disk drive

**SNMP Trap ID**

5

**CIM Information****Prefix: PLAT ID:** 0177**User Response**

No action; information only.

- **816f060d-0416ffff : Array in system [ComputerSystemElementName] has been restored. (Drive 22)**

This message is for the use case when an implementation has detected that a Failed Array has been Restored.

May also be shown as 816f060d0416ffff or 0x816f060d0416ffff

**Severity**

Info

**Serviceable**

No

**Automatically notify support**

No

**Alert Category**

Critical - Hard Disk drive

**SNMP Trap ID**

5

**CIM Information**

Prefix: PLAT ID: 0177

**User Response**

No action; information only.

- **816f060d-0417ffff : Array in system [ComputerSystemElementName] has been restored. (Drive 23)**

This message is for the use case when an implementation has detected that a Failed Array has been Restored.

May also be shown as 816f060d0417ffff or 0x816f060d0417ffff

**Severity**

Info

**Serviceable**

No

**Automatically notify support**

No

**Alert Category**

Critical - Hard Disk drive

**SNMP Trap ID**

5

**CIM Information**

Prefix: PLAT ID: 0177

**User Response**

No action; information only.

- **816f060d-0418ffff : Array in system [ComputerSystemElementName] has been restored. (Drive 24)**

This message is for the use case when an implementation has detected that a Failed Array has been Restored.

May also be shown as 816f060d0418ffff or 0x816f060d0418ffff

**Severity**

Info

**Serviceable**

No

**Automatically notify support**

No

**Alert Category**

Critical - Hard Disk drive

**SNMP Trap ID**

5

**CIM Information**

Prefix: PLAT ID: 0177

**User Response**

No action; information only.

- **816f060d-0419ffff : Array in system [ComputerSystemElementName] has been restored. (Drive 25)**

This message is for the use case when an implementation has detected that a Failed Array has been Restored.

May also be shown as 816f060d0419ffff or 0x816f060d0419ffff

**Severity**

Info

**Serviceable**

No

**Automatically notify support**

No

**Alert Category**

Critical - Hard Disk drive

**SNMP Trap ID**

5

**CIM Information**

Prefix: PLAT ID: 0177

**User Response**

No action; information only.

- **816f060d-041affff : Array in system [ComputerSystemElementName] has been restored. (Drive 26)**

This message is for the use case when an implementation has detected that a Failed Array has been Restored.

May also be shown as 816f060d041affff or 0x816f060d041affff

**Severity**

Info

**Serviceable**

No

**Automatically notify support**

No

**Alert Category**

Critical - Hard Disk drive

**SNMP Trap ID**

5

**CIM Information**

Prefix: PLAT ID: 0177

**User Response**

No action; information only.

- **816f060d-041bffff : Array in system [ComputerSystemElementName] has been restored. (Drive 27)**

This message is for the use case when an implementation has detected that a Failed Array has been Restored.

May also be shown as 816f060d041bffff or 0x816f060d041bffff

**Severity**

Info

**Serviceable**

No

**Automatically notify support**

No

**Alert Category**

Critical - Hard Disk drive

**SNMP Trap ID**

5

**CIM Information**

Prefix: PLAT ID: 0177

**User Response**

No action; information only.

- **816f060d-041cffff : Array in system [ComputerSystemElementName] has been restored. (Drive 28)**

This message is for the use case when an implementation has detected that a Failed Array has been Restored.

May also be shown as 816f060d041cffff or 0x816f060d041cffff

**Severity**

Info

**Serviceable**

No

**Automatically notify support**

No

**Alert Category**

Critical - Hard Disk drive

**SNMP Trap ID**

5

**CIM Information**

Prefix: PLAT ID: 0177

**User Response**

No action; information only.

- **816f060d-041dffff : Array in system [ComputerSystemElementName] has been restored. (Drive 29)**

This message is for the use case when an implementation has detected that a Failed Array has been Restored.

May also be shown as 816f060d041dffff or 0x816f060d041dffff

**Severity**

Info

**Serviceable**

No

**Automatically notify support**

No

**Alert Category**

Critical - Hard Disk drive

**SNMP Trap ID**

5

**CIM Information**

Prefix: PLAT ID: 0177

**User Response**

No action; information only.

- **816f060d-041effff : Array in system [ComputerSystemElementName] has been restored. (Drive 30)**

This message is for the use case when an implementation has detected that a Failed Array has been Restored.

May also be shown as 816f060d041effff or 0x816f060d041effff

**Severity**

Info

**Serviceable**

No

**Automatically notify support**

No

**Alert Category**

Critical - Hard Disk drive

**SNMP Trap ID**

5

**CIM Information**

Prefix: PLAT ID: 0177

**User Response**

No action; information only.

- **816f060d-041fffff : Array in system [ComputerSystemElementName] has been restored. (Drive 31)**

This message is for the use case when an implementation has detected that a Failed Array has been Restored.

May also be shown as 816f060d041fffff or 0x816f060d041fffff

**Severity**

Info

**Serviceable**

No

**Automatically notify support**

No

**Alert Category**

Critical - Hard Disk drive

**SNMP Trap ID**

5

**CIM Information**

Prefix: PLAT ID: 0177

**User Response**

No action; information only.

- **816f060d-0420ffff : Array in system [ComputerSystemElementName] has been restored. (Ext Drive)**

This message is for the use case when an implementation has detected that a Failed Array has been Restored.

May also be shown as 816f060d0420ffff or 0x816f060d0420ffff

**Severity**

Info



**Serviceable**

No

**Automatically notify support**

No

**Alert Category**

Critical - Hard Disk drive

**SNMP Trap ID**

5

**CIM Information**

Prefix: PLAT ID: 0177

**User Response**

No action; information only.

- **816f070c-2001ffff : Configuration error for [PhysicalMemoryElementName] on Subsystem [MemoryElementName]has deasserted. (DIMM 1)**

This message is for the use case when an implementation has detected a Memory DIMM configuration error has deasserted.

May also be shown as 816f070c2001ffff or 0x816f070c2001ffff

**Severity**

Info

**Serviceable**

No

**Automatically notify support**

No

**Alert Category**

Critical - Memory

**SNMP Trap ID**

41

**CIM Information**

Prefix: PLAT ID: 0127

**User Response**

No action; information only.

- **816f070c-2002ffff : Configuration error for [PhysicalMemoryElementName] on Subsystem [MemoryElementName]has deasserted. (DIMM 2)**

This message is for the use case when an implementation has detected a Memory DIMM configuration error has deasserted.

May also be shown as 816f070c2002ffff or 0x816f070c2002ffff

**Severity**

Info

**Serviceable**

No

**Automatically notify support**

No

**Alert Category**

Critical - Memory

**SNMP Trap ID**

41

**CIM Information**

Prefix: PLAT ID: 0127

**User Response**

No action; information only.

- **816f070c-2003ffff : Configuration error for [PhysicalMemoryElementName] on Subsystem [MemoryElementName]has deasserted. (DIMM 3)**

This message is for the use case when an implementation has detected a Memory DIMM configuration error has deasserted.

May also be shown as 816f070c2003ffff or 0x816f070c2003ffff

**Severity**

Info

**Serviceable**

No

**Automatically notify support**

No

**Alert Category**

Critical - Memory

**SNMP Trap ID**

41

**CIM Information**

Prefix: PLAT ID: 0127

**User Response**

No action; information only.

- **816f070c-2004ffff : Configuration error for [PhysicalMemoryElementName] on Subsystem [MemoryElementName]has deasserted. (DIMM 4)**

This message is for the use case when an implementation has detected a Memory DIMM configuration error has deasserted.

May also be shown as 816f070c2004ffff or 0x816f070c2004ffff

**Severity**

Info

**Serviceable**

No

**Automatically notify support**

No

**Alert Category**

Critical - Memory

**SNMP Trap ID**

41

**CIM Information**

Prefix: PLAT ID: 0127

**User Response**

No action; information only.

- **816f070c-2005ffff : Configuration error for [PhysicalMemoryElementName] on Subsystem [MemoryElementName]has deasserted. (DIMM 5)**

This message is for the use case when an implementation has detected a Memory DIMM configuration error has deasserted.

May also be shown as 816f070c2005ffff or 0x816f070c2005ffff

**Severity**

Info

**Serviceable**

No

**Automatically notify support**

No

**Alert Category**

Critical - Memory

**SNMP Trap ID**

41

**CIM Information**

**Prefix: PLAT ID:** 0127

**User Response**

No action; information only.

- **816f070c-2006ffff : Configuration error for [PhysicalMemoryElementName] on Subsystem [MemoryElementName]has deasserted. (DIMM 6)**

This message is for the use case when an implementation has detected a Memory DIMM configuration error has deasserted.

May also be shown as 816f070c2006ffff or 0x816f070c2006ffff

**Severity**

Info

**Serviceable**

No

**Automatically notify support**

No

**Alert Category**

Critical - Memory

**SNMP Trap ID**

41

**CIM Information**

**Prefix: PLAT ID:** 0127

**User Response**

No action; information only.

- **816f070c-2007ffff : Configuration error for [PhysicalMemoryElementName] on Subsystem [MemoryElementName]has deasserted. (DIMM 7)**

This message is for the use case when an implementation has detected a Memory DIMM configuration error has deasserted.

May also be shown as 816f070c2007ffff or 0x816f070c2007ffff

**Severity**

Info

**Serviceable**

No

**Automatically notify support**

No

**Alert Category**

Critical - Memory

**SNMP Trap ID**

41

**CIM Information**

**Prefix: PLAT ID:** 0127

**User Response**

No action; information only.

- **816f070c-2008ffff : Configuration error for [PhysicalMemoryElementName] on Subsystem [MemoryElementName]has deasserted. (DIMM 8)**

This message is for the use case when an implementation has detected a Memory DIMM configuration error has deasserted.

May also be shown as 816f070c2008ffff or 0x816f070c2008ffff

**Severity**

Info

**Serviceable**

No

**Automatically notify support**

No

**Alert Category**

Critical - Memory

**SNMP Trap ID**

41

**CIM Information**

**Prefix: PLAT ID:** 0127

**User Response**

No action; information only.

- **816f070c-2009ffff : Configuration error for [PhysicalMemoryElementName] on Subsystem [MemoryElementName]has deasserted. (DIMM 9)**

This message is for the use case when an implementation has detected a Memory DIMM configuration error has deasserted.

May also be shown as 816f070c2009ffff or 0x816f070c2009ffff

**Severity**

Info

**Serviceable**

No

**Automatically notify support**

No

**Alert Category**

Critical - Memory

**SNMP Trap ID**

41

**CIM Information**

**Prefix:** PLAT ID: 0127

**User Response**

No action; information only.

- **816f070c-200affff : Configuration error for [PhysicalMemoryElementName] on Subsystem [MemoryElementName]has deasserted. (DIMM 10)**

This message is for the use case when an implementation has detected a Memory DIMM configuration error has deasserted.

May also be shown as 816f070c200affff or 0x816f070c200affff

**Severity**

Info

**Serviceable**

No

**Automatically notify support**

No

**Alert Category**

Critical - Memory

**SNMP Trap ID**

41

**CIM Information**

**Prefix:** PLAT ID: 0127

**User Response**

No action; information only.

- **816f070c-200bffff : Configuration error for [PhysicalMemoryElementName] on Subsystem [MemoryElementName]has deasserted. (DIMM 11)**

This message is for the use case when an implementation has detected a Memory DIMM configuration error has deasserted.

May also be shown as 816f070c200bffff or 0x816f070c200bffff

**Severity**

Info

**Serviceable**

No

**Automatically notify support**

No

**Alert Category**

Critical - Memory

**SNMP Trap ID**

41

**CIM Information**

**Prefix:** PLAT ID: 0127

**User Response**

No action; information only.

- **816f070c-200cffff : Configuration error for [PhysicalMemoryElementName] on Subsystem [MemoryElementName]has deasserted. (DIMM 12)**

This message is for the use case when an implementation has detected a Memory DIMM configuration error has deasserted.

May also be shown as 816f070c200cffff or 0x816f070c200cffff

**Severity**

Info

**Serviceable**

No

**Automatically notify support**

No

**Alert Category**

Critical - Memory

**SNMP Trap ID**

41

**CIM Information**

**Prefix: PLAT ID:** 0127

**User Response**

No action; information only.

- **816f070c-200dffff : Configuration error for [PhysicalMemoryElementName] on Subsystem [MemoryElementName]has deasserted. (DIMM 13)**

This message is for the use case when an implementation has detected a Memory DIMM configuration error has deasserted.

May also be shown as 816f070c200dffff or 0x816f070c200dffff

**Severity**

Info

**Serviceable**

No

**Automatically notify support**

No

**Alert Category**

Critical - Memory

**SNMP Trap ID**

41

**CIM Information**

**Prefix: PLAT ID:** 0127

**User Response**

No action; information only.

- **816f070c-200effff : Configuration error for [PhysicalMemoryElementName] on Subsystem [MemoryElementName]has deasserted. (DIMM 14)**

This message is for the use case when an implementation has detected a Memory DIMM configuration error has deasserted.

May also be shown as 816f070c200effff or 0x816f070c200effff

**Severity**

Info

**Serviceable**

No

**Automatically notify support**

No

**Alert Category**

Critical - Memory

**SNMP Trap ID**

41

**CIM Information****Prefix: PLAT ID: 0127****User Response**

No action; information only.

- **816f070c-200ffff : Configuration error for [PhysicalMemoryElementName] on Subsystem [MemoryElementName]has deasserted. (DIMM 15)**

This message is for the use case when an implementation has detected a Memory DIMM configuration error has deasserted.

May also be shown as 816f070c200ffff or 0x816f070c200ffff

**Severity**

Info

**Serviceable**

No

**Automatically notify support**

No

**Alert Category**

Critical - Memory

**SNMP Trap ID**

41

**CIM Information****Prefix: PLAT ID: 0127****User Response**

No action; information only.

- **816f070c-2010fff : Configuration error for [PhysicalMemoryElementName] on Subsystem [MemoryElementName]has deasserted. (DIMM 16)**

This message is for the use case when an implementation has detected a Memory DIMM configuration error has deasserted.

May also be shown as 816f070c2010fff or 0x816f070c2010fff

**Severity**

Info

**Serviceable**

No

**Automatically notify support**

No

**Alert Category**

Critical - Memory

**SNMP Trap ID**

41

**CIM Information**

Prefix: PLAT ID: 0127

**User Response**

No action; information only.

- **816f070c-2011ffff : Configuration error for [PhysicalMemoryElementName] on Subsystem [MemoryElementName]has deasserted. (DIMM 17)**

This message is for the use case when an implementation has detected a Memory DIMM configuration error has deasserted.

May also be shown as 816f070c2011ffff or 0x816f070c2011ffff

**Severity**

Info

**Serviceable**

No

**Automatically notify support**

No

**Alert Category**

Critical - Memory

**SNMP Trap ID**

41

**CIM Information**

Prefix: PLAT ID: 0127

**User Response**

No action; information only.

- **816f070c-2012ffff : Configuration error for [PhysicalMemoryElementName] on Subsystem [MemoryElementName]has deasserted. (DIMM 18)**

This message is for the use case when an implementation has detected a Memory DIMM configuration error has deasserted.

May also be shown as 816f070c2012ffff or 0x816f070c2012ffff

**Severity**

Info

**Serviceable**

No

**Automatically notify support**

No

**Alert Category**

Critical - Memory

**SNMP Trap ID**

41

**CIM Information**

Prefix: PLAT ID: 0127



**User Response**

No action; information only.

- **816f070c-2013ffff : Configuration error for [PhysicalMemoryElementName] on Subsystem [MemoryElementName]has deasserted. (DIMM 19)**

This message is for the use case when an implementation has detected a Memory DIMM configuration error has deasserted.

May also be shown as 816f070c2013ffff or 0x816f070c2013ffff

**Severity**

Info

**Serviceable**

No

**Automatically notify support**

No

**Alert Category**

Critical - Memory

**SNMP Trap ID**

41

**CIM Information**

**Prefix: PLAT ID: 0127**

**User Response**

No action; information only.

- **816f070c-2014ffff : Configuration error for [PhysicalMemoryElementName] on Subsystem [MemoryElementName]has deasserted. (DIMM 20)**

This message is for the use case when an implementation has detected a Memory DIMM configuration error has deasserted.

May also be shown as 816f070c2014ffff or 0x816f070c2014ffff

**Severity**

Info

**Serviceable**

No

**Automatically notify support**

No

**Alert Category**

Critical - Memory

**SNMP Trap ID**

41

**CIM Information**

**Prefix: PLAT ID: 0127**

**User Response**

No action; information only.

- **816f070c-2015ffff : Configuration error for [PhysicalMemoryElementName] on Subsystem [MemoryElementName]has deasserted. (DIMM 21)**

This message is for the use case when an implementation has detected a Memory DIMM configuration error has deasserted.

May also be shown as 816f070c2015ffff or 0x816f070c2015ffff

**Severity**

Info

**Serviceable**

No

**Automatically notify support**

No

**Alert Category**

Critical - Memory

**SNMP Trap ID**

41

**CIM Information****Prefix: PLAT ID:** 0127**User Response**

No action; information only.

- **816f070c-2016ffff : Configuration error for [PhysicalMemoryElementName] on Subsystem [MemoryElementName]has deasserted. (DIMM 22)**

This message is for the use case when an implementation has detected a Memory DIMM configuration error has deasserted.

May also be shown as 816f070c2016ffff or 0x816f070c2016ffff

**Severity**

Info

**Serviceable**

No

**Automatically notify support**

No

**Alert Category**

Critical - Memory

**SNMP Trap ID**

41

**CIM Information****Prefix: PLAT ID:** 0127**User Response**

No action; information only.

- **816f070c-2017ffff : Configuration error for [PhysicalMemoryElementName] on Subsystem [MemoryElementName]has deasserted. (DIMM 23)**

This message is for the use case when an implementation has detected a Memory DIMM configuration error has deasserted.

May also be shown as 816f070c2017ffff or 0x816f070c2017ffff

**Severity**

Info

**Serviceable**

No

**Automatically notify support**

No

**Alert Category**

Critical - Memory

**SNMP Trap ID**

41

**CIM Information**

**Prefix:** PLAT ID: 0127

**User Response**

No action; information only.

- **816f070c-2018ffff : Configuration error for [PhysicalMemoryElementName] on Subsystem [MemoryElementName]has deasserted. (DIMM 24)**

This message is for the use case when an implementation has detected a Memory DIMM configuration error has deasserted.

May also be shown as 816f070c2018ffff or 0x816f070c2018ffff

**Severity**

Info

**Serviceable**

No

**Automatically notify support**

No

**Alert Category**

Critical - Memory

**SNMP Trap ID**

41

**CIM Information**

**Prefix:** PLAT ID: 0127

**User Response**

No action; information only.

- **816f070c-2581ffff : Configuration error for [PhysicalMemoryElementName] on Subsystem [MemoryElementName]has deasserted. (All DIMMS)**

This message is for the use case when an implementation has detected a Memory DIMM configuration error has deasserted.

May also be shown as 816f070c2581ffff or 0x816f070c2581ffff

**Severity**

Info

**Serviceable**

No

**Automatically notify support**

No

**Alert Category**

Critical - Memory

**SNMP Trap ID**

41

**CIM Information**

**Prefix:** PLAT ID: 0127

**User Response**

No action; information only. One of the DIMMs :

- **816f070d-0400ffff : Rebuild completed for Array in system [ComputerSystemElementName]. (Drive 0)**

This message is for the use case when an implementation has detected that an Array Rebuild has Completed.

May also be shown as 816f070d0400ffff or 0x816f070d0400ffff

**Severity**

Info

**Serviceable**

No

**Automatically notify support**

No

**Alert Category**

System - Other

**SNMP Trap ID****CIM Information**

**Prefix: PLAT ID: 0179**

**User Response**

No action; information only.

- **816f070d-0401ffff : Rebuild completed for Array in system [ComputerSystemElementName]. (Drive 1)**

This message is for the use case when an implementation has detected that an Array Rebuild has Completed.

May also be shown as 816f070d0401ffff or 0x816f070d0401ffff

**Severity**

Info

**Serviceable**

No

**Automatically notify support**

No

**Alert Category**

System - Other

**SNMP Trap ID****CIM Information**

**Prefix: PLAT ID: 0179**

**User Response**

No action; information only.

- **816f070d-0402ffff : Rebuild completed for Array in system [ComputerSystemElementName]. (Drive 2)**

This message is for the use case when an implementation has detected that an Array Rebuild has Completed.

May also be shown as 816f070d0402ffff or 0x816f070d0402ffff

**Severity**

Info

**Serviceable**

No

**Automatically notify support**

No

**Alert Category**

System - Other

**SNMP Trap ID****CIM Information****Prefix: PLAT ID:** 0179**User Response**

No action; information only.

- **816f070d-0403ffff : Rebuild completed for Array in system [ComputerSystemElementName]. (Drive 3)**

This message is for the use case when an implementation has detected that an Array Rebuild has Completed.

May also be shown as 816f070d0403ffff or 0x816f070d0403ffff

**Severity**

Info

**Serviceable**

No

**Automatically notify support**

No

**Alert Category**

System - Other

**SNMP Trap ID****CIM Information****Prefix: PLAT ID:** 0179**User Response**

No action; information only.

- **816f070d-0404ffff : Rebuild completed for Array in system [ComputerSystemElementName]. (Drive 4)**

This message is for the use case when an implementation has detected that an Array Rebuild has Completed.

May also be shown as 816f070d0404ffff or 0x816f070d0404ffff

**Severity**

Info

**Serviceable**

No

**Automatically notify support**

No

**Alert Category**  
System - Other

**SNMP Trap ID**

**CIM Information**  
Prefix: PLAT ID: 0179

**User Response**  
No action; information only.

- **816f070d-0405ffff : Rebuild completed for Array in system [ComputerSystemElementName]. (Drive 5)**

This message is for the use case when an implementation has detected that an Array Rebuild has Completed.

May also be shown as 816f070d0405ffff or 0x816f070d0405ffff

**Severity**  
Info

**Serviceable**  
No

**Automatically notify support**  
No

**Alert Category**  
System - Other

**SNMP Trap ID**

**CIM Information**  
Prefix: PLAT ID: 0179

**User Response**  
No action; information only.

- **816f070d-0406ffff : Rebuild completed for Array in system [ComputerSystemElementName]. (Drive 6)**

This message is for the use case when an implementation has detected that an Array Rebuild has Completed.

May also be shown as 816f070d0406ffff or 0x816f070d0406ffff

**Severity**  
Info

**Serviceable**  
No

**Automatically notify support**  
No

**Alert Category**  
System - Other

**SNMP Trap ID**

**CIM Information**  
Prefix: PLAT ID: 0179

**User Response**

No action; information only.

- **816f070d-0407ffff : Rebuild completed for Array in system [ComputerSystemElementName]. (Drive 7)**

This message is for the use case when an implementation has detected that an Array Rebuild has Completed.

May also be shown as 816f070d0407ffff or 0x816f070d0407ffff

**Severity**

Info

**Serviceable**

No

**Automatically notify support**

No

**Alert Category**

System - Other

**SNMP Trap ID****CIM Information**

**Prefix:** PLAT ID: 0179

**User Response**

No action; information only.

- **816f070d-0408ffff : Rebuild completed for Array in system [ComputerSystemElementName]. (Drive 8)**

This message is for the use case when an implementation has detected that an Array Rebuild has Completed.

May also be shown as 816f070d0408ffff or 0x816f070d0408ffff

**Severity**

Info

**Serviceable**

No

**Automatically notify support**

No

**Alert Category**

System - Other

**SNMP Trap ID****CIM Information**

**Prefix:** PLAT ID: 0179

**User Response**

No action; information only.

- **816f070d-0409ffff : Rebuild completed for Array in system [ComputerSystemElementName]. (Drive 9)**

This message is for the use case when an implementation has detected that an Array Rebuild has Completed.

May also be shown as 816f070d0409ffff or 0x816f070d0409ffff

**Severity**

Info

**Serviceable**

No

**Automatically notify support**

No

**Alert Category**

System - Other

**SNMP Trap ID****CIM Information****Prefix: PLAT ID:** 0179**User Response**

No action; information only.

- **816f070d-040affff : Rebuild completed for Array in system [ComputerSystemElementName]. (Drive 10)**

This message is for the use case when an implementation has detected that an Array Rebuild has Completed.

May also be shown as 816f070d040affff or 0x816f070d040affff

**Severity**

Info

**Serviceable**

No

**Automatically notify support**

No

**Alert Category**

System - Other

**SNMP Trap ID****CIM Information****Prefix: PLAT ID:** 0179**User Response**

No action; information only.

- **816f070d-040bffff : Rebuild completed for Array in system [ComputerSystemElementName]. (Drive 11)**

This message is for the use case when an implementation has detected that an Array Rebuild has Completed.

May also be shown as 816f070d040bffff or 0x816f070d040bffff

**Severity**

Info

**Serviceable**

No

**Automatically notify support**

No



**Alert Category**

System - Other

**SNMP Trap ID****CIM Information**

Prefix: PLAT ID: 0179

**User Response**

No action; information only.

- **816f070d-040cffff : Rebuild completed for Array in system [ComputerSystemElementName]. (Drive 12)**

This message is for the use case when an implementation has detected that an Array Rebuild has Completed.

May also be shown as 816f070d040cffff or 0x816f070d040cffff

**Severity**

Info

**Serviceable**

No

**Automatically notify support**

No

**Alert Category**

System - Other

**SNMP Trap ID****CIM Information**

Prefix: PLAT ID: 0179

**User Response**

No action; information only.

- **816f070d-040dffff : Rebuild completed for Array in system [ComputerSystemElementName]. (Drive 13)**

This message is for the use case when an implementation has detected that an Array Rebuild has Completed.

May also be shown as 816f070d040dffff or 0x816f070d040dffff

**Severity**

Info

**Serviceable**

No

**Automatically notify support**

No

**Alert Category**

System - Other

**SNMP Trap ID****CIM Information**

Prefix: PLAT ID: 0179

**User Response**

No action; information only.

- **816f070d-040effff : Rebuild completed for Array in system [ComputerSystemElementName]. (Drive 14)**

This message is for the use case when an implementation has detected that an Array Rebuild has Completed.

May also be shown as 816f070d040effff or 0x816f070d040effff

**Severity**

Info

**Serviceable**

No

**Automatically notify support**

No

**Alert Category**

System - Other

**SNMP Trap ID****CIM Information**

Prefix: PLAT ID: 0179

**User Response**

No action; information only.

- **816f070d-040fffff : Rebuild completed for Array in system [ComputerSystemElementName]. (Drive 15)**

This message is for the use case when an implementation has detected that an Array Rebuild has Completed.

May also be shown as 816f070d040fffff or 0x816f070d040fffff

**Severity**

Info

**Serviceable**

No

**Automatically notify support**

No

**Alert Category**

System - Other

**SNMP Trap ID****CIM Information**

Prefix: PLAT ID: 0179

**User Response**

No action; information only.

- **816f070d-0410ffff : Rebuild completed for Array in system [ComputerSystemElementName]. (Drive 16)**

This message is for the use case when an implementation has detected that an Array Rebuild has Completed.

May also be shown as 816f070d0410ffff or 0x816f070d0410ffff

**Severity**

Info

**Serviceable**

No

**Automatically notify support**

No

**Alert Category**

System - Other

**SNMP Trap ID****CIM Information****Prefix: PLAT ID:** 0179**User Response**

No action; information only.

- **816f070d-0411ffff : Rebuild completed for Array in system [ComputerSystemElementName]. (Drive 17)**

This message is for the use case when an implementation has detected that an Array Rebuild has Completed.

May also be shown as 816f070d0411ffff or 0x816f070d0411ffff

**Severity**

Info

**Serviceable**

No

**Automatically notify support**

No

**Alert Category**

System - Other

**SNMP Trap ID****CIM Information****Prefix: PLAT ID:** 0179**User Response**

No action; information only.

- **816f070d-0412ffff : Rebuild completed for Array in system [ComputerSystemElementName]. (Drive 18)**

This message is for the use case when an implementation has detected that an Array Rebuild has Completed.

May also be shown as 816f070d0412ffff or 0x816f070d0412ffff

**Severity**

Info

**Serviceable**

No

**Automatically notify support**

No

**Alert Category**  
System - Other

**SNMP Trap ID**

**CIM Information**  
Prefix: PLAT ID: 0179

**User Response**  
No action; information only.

- **816f070d-0413ffff : Rebuild completed for Array in system [ComputerSystemElementName]. (Drive 19)**

This message is for the use case when an implementation has detected that an Array Rebuild has Completed.

May also be shown as 816f070d0413ffff or 0x816f070d0413ffff

**Severity**  
Info

**Serviceable**  
No

**Automatically notify support**  
No

**Alert Category**  
System - Other

**SNMP Trap ID**

**CIM Information**  
Prefix: PLAT ID: 0179

**User Response**  
No action; information only.

- **816f070d-0414ffff : Rebuild completed for Array in system [ComputerSystemElementName]. (Drive 20)**

This message is for the use case when an implementation has detected that an Array Rebuild has Completed.

May also be shown as 816f070d0414ffff or 0x816f070d0414ffff

**Severity**  
Info

**Serviceable**  
No

**Automatically notify support**  
No

**Alert Category**  
System - Other

**SNMP Trap ID**

**CIM Information**  
Prefix: PLAT ID: 0179

**User Response**

No action; information only.

- **816f070d-0415ffff : Rebuild completed for Array in system [ComputerSystemElementName]. (Drive 21)**

This message is for the use case when an implementation has detected that an Array Rebuild has Completed.

May also be shown as 816f070d0415ffff or 0x816f070d0415ffff

**Severity**

Info

**Serviceable**

No

**Automatically notify support**

No

**Alert Category**

System - Other

**SNMP Trap ID****CIM Information**

**Prefix:** PLAT ID: 0179

**User Response**

No action; information only.

- **816f070d-0416ffff : Rebuild completed for Array in system [ComputerSystemElementName]. (Drive 22)**

This message is for the use case when an implementation has detected that an Array Rebuild has Completed.

May also be shown as 816f070d0416ffff or 0x816f070d0416ffff

**Severity**

Info

**Serviceable**

No

**Automatically notify support**

No

**Alert Category**

System - Other

**SNMP Trap ID****CIM Information**

**Prefix:** PLAT ID: 0179

**User Response**

No action; information only.

- **816f070d-0417ffff : Rebuild completed for Array in system [ComputerSystemElementName]. (Drive 23)**

This message is for the use case when an implementation has detected that an Array Rebuild has Completed.

May also be shown as 816f070d0417ffff or 0x816f070d0417ffff

**Severity**

Info

**Serviceable**

No

**Automatically notify support**

No

**Alert Category**

System - Other

**SNMP Trap ID****CIM Information****Prefix: PLAT ID:** 0179**User Response**

No action; information only.

- **816f070d-0418ffff : Rebuild completed for Array in system [ComputerSystemElementName]. (Drive 24)**

This message is for the use case when an implementation has detected that an Array Rebuild has Completed.

May also be shown as 816f070d0418ffff or 0x816f070d0418ffff

**Severity**

Info

**Serviceable**

No

**Automatically notify support**

No

**Alert Category**

System - Other

**SNMP Trap ID****CIM Information****Prefix: PLAT ID:** 0179**User Response**

No action; information only.

- **816f070d-0419ffff : Rebuild completed for Array in system [ComputerSystemElementName]. (Drive 25)**

This message is for the use case when an implementation has detected that an Array Rebuild has Completed.

May also be shown as 816f070d0419ffff or 0x816f070d0419ffff

**Severity**

Info

**Serviceable**

No

**Automatically notify support**

No

**Alert Category**

System - Other

**SNMP Trap ID****CIM Information**

Prefix: PLAT ID: 0179

**User Response**

No action; information only.

- **816f070d-041affff : Rebuild completed for Array in system [ComputerSystemElementName]. (Drive 26)**

This message is for the use case when an implementation has detected that an Array Rebuild has Completed.

May also be shown as 816f070d041affff or 0x816f070d041affff

**Severity**

Info

**Serviceable**

No

**Automatically notify support**

No

**Alert Category**

System - Other

**SNMP Trap ID****CIM Information**

Prefix: PLAT ID: 0179

**User Response**

No action; information only.

- **816f070d-041bffff : Rebuild completed for Array in system [ComputerSystemElementName]. (Drive 27)**

This message is for the use case when an implementation has detected that an Array Rebuild has Completed.

May also be shown as 816f070d041bffff or 0x816f070d041bffff

**Severity**

Info

**Serviceable**

No

**Automatically notify support**

No

**Alert Category**

System - Other

**SNMP Trap ID****CIM Information**

Prefix: PLAT ID: 0179

**User Response**

No action; information only.

- **816f070d-041cffff : Rebuild completed for Array in system [ComputerSystemElementName]. (Drive 28)**

This message is for the use case when an implementation has detected that an Array Rebuild has Completed.

May also be shown as 816f070d041cffff or 0x816f070d041cffff

**Severity**

Info

**Serviceable**

No

**Automatically notify support**

No

**Alert Category**

System - Other

**SNMP Trap ID****CIM Information**

Prefix: PLAT ID: 0179

**User Response**

No action; information only.

- **816f070d-041dffff : Rebuild completed for Array in system [ComputerSystemElementName]. (Drive 29)**

This message is for the use case when an implementation has detected that an Array Rebuild has Completed.

May also be shown as 816f070d041dffff or 0x816f070d041dffff

**Severity**

Info

**Serviceable**

No

**Automatically notify support**

No

**Alert Category**

System - Other

**SNMP Trap ID****CIM Information**

Prefix: PLAT ID: 0179

**User Response**

No action; information only.

- **816f070d-041effff : Rebuild completed for Array in system [ComputerSystemElementName]. (Drive 30)**

This message is for the use case when an implementation has detected that an Array Rebuild has Completed.

May also be shown as 816f070d041effff or 0x816f070d041effff



**Severity**

Info

**Serviceable**

No

**Automatically notify support**

No

**Alert Category**

System - Other

**SNMP Trap ID****CIM Information****Prefix:** PLAT ID: 0179**User Response**

No action; information only.

- **816f070d-041ffff : Rebuild completed for Array in system [ComputerSystemElementName]. (Drive 31)**

This message is for the use case when an implementation has detected that an Array Rebuild has Completed.

May also be shown as 816f070d041ffff or 0x816f070d041ffff

**Severity**

Info

**Serviceable**

No

**Automatically notify support**

No

**Alert Category**

System - Other

**SNMP Trap ID****CIM Information****Prefix:** PLAT ID: 0179**User Response**

No action; information only.

- **816f070d-0420fff : Rebuild completed for Array in system [ComputerSystemElementName]. (Ext Drive)**

This message is for the use case when an implementation has detected that an Array Rebuild has Completed.

May also be shown as 816f070d0420fff or 0x816f070d0420fff

**Severity**

Info

**Serviceable**

No

**Automatically notify support**

No

**Alert Category**  
System - Other

**SNMP Trap ID**

**CIM Information**  
Prefix: PLAT ID: 0179

**User Response**  
No action; information only.

- **816f0807-0301ffff : [ProcessorElementName] has been Enabled. (CPU 1)**

This message is for the use case when an implementation has detected a Processor has been Enabled.  
May also be shown as 816f08070301ffff or 0x816f08070301ffff

**Severity**  
Info

**Serviceable**  
No

**Automatically notify support**  
No

**Alert Category**  
System - Other

**SNMP Trap ID**

**CIM Information**  
Prefix: PLAT ID: 0060

**User Response**  
No action; information only.

- **816f0807-0302ffff : [ProcessorElementName] has been Enabled. (CPU 2)**

This message is for the use case when an implementation has detected a Processor has been Enabled.  
May also be shown as 816f08070302ffff or 0x816f08070302ffff

**Severity**  
Info

**Serviceable**  
No

**Automatically notify support**  
No

**Alert Category**  
System - Other

**SNMP Trap ID**

**CIM Information**  
Prefix: PLAT ID: 0060

**User Response**  
No action; information only.

- **816f0807-2584ffff : [ProcessorElementName] has been Enabled. (All CPUs)**

This message is for the use case when an implementation has detected a Processor has been Enabled.

May also be shown as 816f08072584ffff or 0x816f08072584ffff

**Severity**

Info

**Serviceable**

No

**Automatically notify support**

No

**Alert Category**

System - Other

**SNMP Trap ID**

**CIM Information**

Prefix: PLAT ID: 0060

**User Response**

No action; information only. One of the CPUs :

- **816f0813-2581ffff : System [ComputerSystemElementName] has recovered from an Uncorrectable Bus Error. (DIMMs)**

This message is for the use case when an implementation has detected a that a system has recovered from a Bus Uncorrectable Error.

May also be shown as 816f08132581ffff or 0x816f08132581ffff

**Severity**

Info

**Serviceable**

No

**Automatically notify support**

No

**Alert Category**

Critical - Other

**SNMP Trap ID**

50

**CIM Information**

Prefix: PLAT ID: 0241

**User Response**

No action; information only.

- **816f0813-2582ffff : System [ComputerSystemElementName] has recovered from an Uncorrectable Bus Error. (PCIs)**

This message is for the use case when an implementation has detected a that a system has recovered from a Bus Uncorrectable Error.

May also be shown as 816f08132582ffff or 0x816f08132582ffff

**Severity**

Info

**Serviceable**

No

**Automatically notify support**

No

**Alert Category**

Critical - Other

**SNMP Trap ID**

50

**CIM Information**

Prefix: PLAT ID: 0241

**User Response**

No action; information only.

- **816f0813-2584ffff : System [ComputerSystemElementName] has recovered from an Uncorrectable Bus Error. (CPUs)**

This message is for the use case when an implementation has detected a that a system has recovered from a Bus Uncorrectable Error.

May also be shown as 816f08132584ffff or 0x816f08132584ffff

**Severity**

Info

**Serviceable**

No

**Automatically notify support**

No

**Alert Category**

Critical - Other

**SNMP Trap ID**

50

**CIM Information**

Prefix: PLAT ID: 0241

**User Response**

No action; information only.

- **816f090c-2001ffff : [PhysicalMemoryElementName] on Subsystem [MemoryElementName] is no longer Throttled. (DIMM 1)**

This message is for the use case when an implementation has detected Memory is no longer Throttled.

May also be shown as 816f090c2001ffff or 0x816f090c2001ffff

**Severity**

Info

**Serviceable**

No

**Automatically notify support**

No

**Alert Category**

System - Other

**SNMP Trap ID****CIM Information**

**Prefix:** PLAT ID: 0143

**User Response**

No action; information only.

- **816f090c-2002ffff : [PhysicalMemoryElementName] on Subsystem [MemoryElementName] is no longer Throttled. (DIMM 2)**

This message is for the use case when an implementation has detected Memory is no longer Throttled.

May also be shown as 816f090c2002ffff or 0x816f090c2002ffff

**Severity**

Info

**Serviceable**

No

**Automatically notify support**

No

**Alert Category**

System - Other

**SNMP Trap ID**

**CIM Information**

**Prefix:** PLAT ID: 0143

**User Response**

No action; information only.

- **816f090c-2003ffff : [PhysicalMemoryElementName] on Subsystem [MemoryElementName] is no longer Throttled. (DIMM 3)**

This message is for the use case when an implementation has detected Memory is no longer Throttled.

May also be shown as 816f090c2003ffff or 0x816f090c2003ffff

**Severity**

Info

**Serviceable**

No

**Automatically notify support**

No

**Alert Category**

System - Other

**SNMP Trap ID**

**CIM Information**

**Prefix:** PLAT ID: 0143

**User Response**

No action; information only.

- **816f090c-2004ffff : [PhysicalMemoryElementName] on Subsystem [MemoryElementName] is no longer Throttled. (DIMM 4)**

This message is for the use case when an implementation has detected Memory is no longer Throttled.

May also be shown as 816f090c2004ffff or 0x816f090c2004ffff

**Severity**

Info

**Serviceable**

No

**Automatically notify support**

No

**Alert Category**

System - Other

**SNMP Trap ID****CIM Information**

Prefix: PLAT ID: 0143

**User Response**

No action; information only.

- **816f090c-2005ffff : [PhysicalMemoryElementName] on Subsystem [MemoryElementName] is no longer Throttled. (DIMM 5)**

This message is for the use case when an implementation has detected Memory is no longer Throttled.

May also be shown as 816f090c2005ffff or 0x816f090c2005ffff

**Severity**

Info

**Serviceable**

No

**Automatically notify support**

No

**Alert Category**

System - Other

**SNMP Trap ID****CIM Information**

Prefix: PLAT ID: 0143

**User Response**

No action; information only.

- **816f090c-2006ffff : [PhysicalMemoryElementName] on Subsystem [MemoryElementName] is no longer Throttled. (DIMM 6)**

This message is for the use case when an implementation has detected Memory is no longer Throttled.

May also be shown as 816f090c2006ffff or 0x816f090c2006ffff

**Severity**

Info

**Serviceable**

No

**Automatically notify support**

No

**Alert Category**

System - Other

## SNMP Trap ID

### CIM Information

Prefix: PLAT ID: 0143

### User Response

No action; information only.

- **816f090c-2007ffff : [PhysicalMemoryElementName] on Subsystem [MemoryElementName] is no longer Throttled. (DIMM 7)**

This message is for the use case when an implementation has detected Memory is no longer Throttled.

May also be shown as 816f090c2007ffff or 0x816f090c2007ffff

### Severity

Info

### Serviceable

No

### Automatically notify support

No

### Alert Category

System - Other

## SNMP Trap ID

### CIM Information

Prefix: PLAT ID: 0143

### User Response

No action; information only.

- **816f090c-2008ffff : [PhysicalMemoryElementName] on Subsystem [MemoryElementName] is no longer Throttled. (DIMM 8)**

This message is for the use case when an implementation has detected Memory is no longer Throttled.

May also be shown as 816f090c2008ffff or 0x816f090c2008ffff

### Severity

Info

### Serviceable

No

### Automatically notify support

No

### Alert Category

System - Other

## SNMP Trap ID

### CIM Information

Prefix: PLAT ID: 0143

### User Response

No action; information only.

- **816f090c-2009ffff : [PhysicalMemoryElementName] on Subsystem [MemoryElementName] is no longer Throttled. (DIMM 9)**

This message is for the use case when an implementation has detected Memory is no longer Throttled.  
May also be shown as 816f090c2009ffff or 0x816f090c2009ffff

**Severity**

Info

**Serviceable**

No

**Automatically notify support**

No

**Alert Category**

System - Other

**SNMP Trap ID**

**CIM Information**

Prefix: PLAT ID: 0143

**User Response**

No action; information only.

- **816f090c-200affff : [PhysicalMemoryElementName] on Subsystem [MemoryElementName] is no longer Throttled. (DIMM 10)**

This message is for the use case when an implementation has detected Memory is no longer Throttled.

May also be shown as 816f090c200affff or 0x816f090c200affff

**Severity**

Info

**Serviceable**

No

**Automatically notify support**

No

**Alert Category**

System - Other

**SNMP Trap ID**

**CIM Information**

Prefix: PLAT ID: 0143

**User Response**

No action; information only.

- **816f090c-200bffff : [PhysicalMemoryElementName] on Subsystem [MemoryElementName] is no longer Throttled. (DIMM 11)**

This message is for the use case when an implementation has detected Memory is no longer Throttled.

May also be shown as 816f090c200bffff or 0x816f090c200bffff

**Severity**

Info

**Serviceable**

No

**Automatically notify support**



No

**Alert Category**

System - Other

**SNMP Trap ID**

**CIM Information**

Prefix: PLAT ID: 0143

**User Response**

No action; information only.

- **816f090c-200cffff : [PhysicalMemoryElementName] on Subsystem [MemoryElementName] is no longer Throttled. (DIMM 12)**

This message is for the use case when an implementation has detected Memory is no longer Throttled.

May also be shown as 816f090c200cffff or 0x816f090c200cffff

**Severity**

Info

**Serviceable**

No

**Automatically notify support**

No

**Alert Category**

System - Other

**SNMP Trap ID**

**CIM Information**

Prefix: PLAT ID: 0143

**User Response**

No action; information only.

- **816f090c-200dffff : [PhysicalMemoryElementName] on Subsystem [MemoryElementName] is no longer Throttled. (DIMM 13)**

This message is for the use case when an implementation has detected Memory is no longer Throttled.

May also be shown as 816f090c200dffff or 0x816f090c200dffff

**Severity**

Info

**Serviceable**

No

**Automatically notify support**

No

**Alert Category**

System - Other

**SNMP Trap ID**

**CIM Information**

Prefix: PLAT ID: 0143

**User Response**

No action; information only.

- **816f090c-200effff : [PhysicalMemoryElementName] on Subsystem [MemoryElementName] is no longer Throttled. (DIMM 14)**

This message is for the use case when an implementation has detected Memory is no longer Throttled. May also be shown as 816f090c200effff or 0x816f090c200effff

**Severity**

Info

**Serviceable**

No

**Automatically notify support**

No

**Alert Category**

System - Other

**SNMP Trap ID****CIM Information**

Prefix: PLAT ID: 0143

**User Response**

No action; information only.

- **816f090c-200fffff : [PhysicalMemoryElementName] on Subsystem [MemoryElementName] is no longer Throttled. (DIMM 15)**

This message is for the use case when an implementation has detected Memory is no longer Throttled. May also be shown as 816f090c200fffff or 0x816f090c200fffff

**Severity**

Info

**Serviceable**

No

**Automatically notify support**

No

**Alert Category**

System - Other

**SNMP Trap ID****CIM Information**

Prefix: PLAT ID: 0143

**User Response**

No action; information only.

- **816f090c-2010ffff : [PhysicalMemoryElementName] on Subsystem [MemoryElementName] is no longer Throttled. (DIMM 16)**

This message is for the use case when an implementation has detected Memory is no longer Throttled. May also be shown as 816f090c2010ffff or 0x816f090c2010ffff

**Severity**

Info

**Serviceable**

No

**Automatically notify support**

No

**Alert Category**

System - Other

**SNMP Trap ID****CIM Information**

Prefix: PLAT ID: 0143

**User Response**

No action; information only.

- **816f090c-2011ffff : [PhysicalMemoryElementName] on Subsystem [MemoryElementName] is no longer Throttled. (DIMM 17)**

This message is for the use case when an implementation has detected Memory is no longer Throttled.

May also be shown as 816f090c2011ffff or 0x816f090c2011ffff

**Severity**

Info

**Serviceable**

No

**Automatically notify support**

No

**Alert Category**

System - Other

**SNMP Trap ID****CIM Information**

Prefix: PLAT ID: 0143

**User Response**

No action; information only.

- **816f090c-2012ffff : [PhysicalMemoryElementName] on Subsystem [MemoryElementName] is no longer Throttled. (DIMM 18)**

This message is for the use case when an implementation has detected Memory is no longer Throttled.

May also be shown as 816f090c2012ffff or 0x816f090c2012ffff

**Severity**

Info

**Serviceable**

No

**Automatically notify support**

No

**Alert Category**

System - Other

**SNMP Trap ID**

**CIM Information**

Prefix: PLAT ID: 0143

**User Response**

No action; information only.

- **816f090c-2013ffff : [PhysicalMemoryElementName] on Subsystem [MemoryElementName] is no longer Throttled. (DIMM 19)**

This message is for the use case when an implementation has detected Memory is no longer Throttled.

May also be shown as 816f090c2013ffff or 0x816f090c2013ffff

**Severity**

Info

**Serviceable**

No

**Automatically notify support**

No

**Alert Category**

System - Other

**SNMP Trap ID****CIM Information**

Prefix: PLAT ID: 0143

**User Response**

No action; information only.

- **816f090c-2014ffff : [PhysicalMemoryElementName] on Subsystem [MemoryElementName] is no longer Throttled. (DIMM 20)**

This message is for the use case when an implementation has detected Memory is no longer Throttled.

May also be shown as 816f090c2014ffff or 0x816f090c2014ffff

**Severity**

Info

**Serviceable**

No

**Automatically notify support**

No

**Alert Category**

System - Other

**SNMP Trap ID****CIM Information**

Prefix: PLAT ID: 0143

**User Response**

No action; information only.

- **816f090c-2015ffff : [PhysicalMemoryElementName] on Subsystem [MemoryElementName] is no longer Throttled. (DIMM 21)**

This message is for the use case when an implementation has detected Memory is no longer Throttled.

May also be shown as 816f090c2015ffff or 0x816f090c2015ffff

**Severity**

Info

**Serviceable**

No

**Automatically notify support**

No

**Alert Category**

System - Other

**SNMP Trap ID****CIM Information**

Prefix: PLAT ID: 0143

**User Response**

No action; information only.

- **816f090c-2016ffff : [PhysicalMemoryElementName] on Subsystem [MemoryElementName] is no longer Throttled. (DIMM 22)**

This message is for the use case when an implementation has detected Memory is no longer Throttled.

May also be shown as 816f090c2016ffff or 0x816f090c2016ffff

**Severity**

Info

**Serviceable**

No

**Automatically notify support**

No

**Alert Category**

System - Other

**SNMP Trap ID****CIM Information**

Prefix: PLAT ID: 0143

**User Response**

No action; information only.

- **816f090c-2017ffff : [PhysicalMemoryElementName] on Subsystem [MemoryElementName] is no longer Throttled. (DIMM 23)**

This message is for the use case when an implementation has detected Memory is no longer Throttled.

May also be shown as 816f090c2017ffff or 0x816f090c2017ffff

**Severity**

Info

**Serviceable**

No

**Automatically notify support**

No

**Alert Category**

System - Other

## SNMP Trap ID

### CIM Information

Prefix: PLAT ID: 0143

### User Response

No action; information only.

- **816f090c-2018ffff : [PhysicalMemoryElementName] on Subsystem [MemoryElementName] is no longer Throttled. (DIMM 24)**

This message is for the use case when an implementation has detected Memory is no longer Throttled.

May also be shown as 816f090c2018ffff or 0x816f090c2018ffff

### Severity

Info

### Serviceable

No

### Automatically notify support

No

### Alert Category

System - Other

## SNMP Trap ID

### CIM Information

Prefix: PLAT ID: 0143

### User Response

No action; information only.

- **816f0a07-0301ffff : The Processor [ProcessorElementName] is no longer operating in a Degraded State. (CPU 1)**

This message is for the use case when an implementation has detected a Processor is no longer running in the Degraded state.

May also be shown as 816f0a070301ffff or 0x816f0a070301ffff

### Severity

Info

### Serviceable

No

### Automatically notify support

No

### Alert Category

Warning - CPU

## SNMP Trap ID

42

### CIM Information

Prefix: PLAT ID: 0039

### User Response

No action; information only.

- **816f0a07-0302ffff : The Processor [ProcessorElementName] is no longer operating in a Degraded State. (CPU 2)**

This message is for the use case when an implementation has detected a Processor is no longer running in the Degraded state.

May also be shown as 816f0a070302ffff or 0x816f0a070302ffff

**Severity**

Info

**Serviceable**

No

**Automatically notify support**

No

**Alert Category**

Warning - CPU

**SNMP Trap ID**

42

**CIM Information**

**Prefix: PLAT ID:** 0039

**User Response**

No action; information only.

- **816f0a0c-2001ffff : An Over-Temperature Condition has been removed on the [PhysicalMemoryElementName] on Subsystem [MemoryElementName]. (DIMM 1)**

This message is for the use case when an implementation has detected an Over Temperature Condition for Memory that has been Removed.

May also be shown as 816f0a0c2001ffff or 0x816f0a0c2001ffff

**Severity**

Info

**Serviceable**

No

**Automatically notify support**

No

**Alert Category**

Critical - Temperature

**SNMP Trap ID**

0

**CIM Information**

**Prefix: PLAT ID:** 0147

**User Response**

No action; information only.

- **816f0a0c-2002ffff : An Over-Temperature Condition has been removed on the [PhysicalMemoryElementName] on Subsystem [MemoryElementName]. (DIMM 2)**

This message is for the use case when an implementation has detected an Over Temperature Condition for Memory that has been Removed.

May also be shown as 816f0a0c2002ffff or 0x816f0a0c2002ffff

**Severity**

Info

**Serviceable**

No

**Automatically notify support**

No

**Alert Category**

Critical - Temperature

**SNMP Trap ID**

0

**CIM Information**

Prefix: PLAT ID: 0147

**User Response**

No action; information only.

- **816f0a0c-2003ffff : An Over-Temperature Condition has been removed on the [PhysicalMemoryElementName] on Subsystem [MemoryElementName]. (DIMM 3)**

This message is for the use case when an implementation has detected an Over Temperature Condition for Memory that has been Removed.

May also be shown as 816f0a0c2003ffff or 0x816f0a0c2003ffff

**Severity**

Info

**Serviceable**

No

**Automatically notify support**

No

**Alert Category**

Critical - Temperature

**SNMP Trap ID**

0

**CIM Information**

Prefix: PLAT ID: 0147

**User Response**

No action; information only.

- **816f0a0c-2004ffff : An Over-Temperature Condition has been removed on the [PhysicalMemoryElementName] on Subsystem [MemoryElementName]. (DIMM 4)**

This message is for the use case when an implementation has detected an Over Temperature Condition for Memory that has been Removed.

May also be shown as 816f0a0c2004ffff or 0x816f0a0c2004ffff

**Severity**

Info

**Serviceable**

No

**Automatically notify support**

No

**Alert Category**



Critical - Temperature

**SNMP Trap ID**

0

**CIM Information**

**Prefix:** PLAT ID: 0147

**User Response**

No action; information only.

- **816f0a0c-2005ffff : An Over-Temperature Condition has been removed on the [PhysicalMemoryElementName] on Subsystem [MemoryElementName]. (DIMM 5)**

This message is for the use case when an implementation has detected an Over Temperature Condition for Memory that has been Removed.

May also be shown as 816f0a0c2005ffff or 0x816f0a0c2005ffff

**Severity**

Info

**Serviceable**

No

**Automatically notify support**

No

**Alert Category**

Critical - Temperature

**SNMP Trap ID**

0

**CIM Information**

**Prefix:** PLAT ID: 0147

**User Response**

No action; information only.

- **816f0a0c-2006ffff : An Over-Temperature Condition has been removed on the [PhysicalMemoryElementName] on Subsystem [MemoryElementName]. (DIMM 6)**

This message is for the use case when an implementation has detected an Over Temperature Condition for Memory that has been Removed.

May also be shown as 816f0a0c2006ffff or 0x816f0a0c2006ffff

**Severity**

Info

**Serviceable**

No

**Automatically notify support**

No

**Alert Category**

Critical - Temperature

**SNMP Trap ID**

0

**CIM Information**

**Prefix:** PLAT ID: 0147

**User Response**

No action; information only.

- **816f0a0c-2007ffff : An Over-Temperature Condition has been removed on the [PhysicalMemoryElementName] on Subsystem [MemoryElementName]. (DIMM 7)**

This message is for the use case when an implementation has detected an Over Temperature Condition for Memory that has been Removed.

May also be shown as 816f0a0c2007ffff or 0x816f0a0c2007ffff

**Severity**

Info

**Serviceable**

No

**Automatically notify support**

No

**Alert Category**

Critical - Temperature

**SNMP Trap ID**

0

**CIM Information**

Prefix: PLAT ID: 0147

**User Response**

No action; information only.

- **816f0a0c-2008ffff : An Over-Temperature Condition has been removed on the [PhysicalMemoryElementName] on Subsystem [MemoryElementName]. (DIMM 8)**

This message is for the use case when an implementation has detected an Over Temperature Condition for Memory that has been Removed.

May also be shown as 816f0a0c2008ffff or 0x816f0a0c2008ffff

**Severity**

Info

**Serviceable**

No

**Automatically notify support**

No

**Alert Category**

Critical - Temperature

**SNMP Trap ID**

0

**CIM Information**

Prefix: PLAT ID: 0147

**User Response**

No action; information only.

- **816f0a0c-2009ffff : An Over-Temperature Condition has been removed on the [PhysicalMemoryElementName] on Subsystem [MemoryElementName]. (DIMM 9)**

This message is for the use case when an implementation has detected an Over Temperature Condition for Memory that has been Removed.

May also be shown as 816f0a0c2009ffff or 0x816f0a0c2009ffff

**Severity**

Info

**Serviceable**

No

**Automatically notify support**

No

**Alert Category**

Critical - Temperature

**SNMP Trap ID**

0

**CIM Information****Prefix: PLAT ID:** 0147**User Response**

No action; information only.

- **816f0a0c-200afff : An Over-Temperature Condition has been removed on the [PhysicalMemoryElementName] on Subsystem [MemoryElementName]. (DIMM 10)**

This message is for the use case when an implementation has detected an Over Temperature Condition for Memory that has been Removed.

May also be shown as 816f0a0c200afff or 0x816f0a0c200afff

**Severity**

Info

**Serviceable**

No

**Automatically notify support**

No

**Alert Category**

Critical - Temperature

**SNMP Trap ID**

0

**CIM Information****Prefix: PLAT ID:** 0147**User Response**

No action; information only.

- **816f0a0c-200bfff : An Over-Temperature Condition has been removed on the [PhysicalMemoryElementName] on Subsystem [MemoryElementName]. (DIMM 11)**

This message is for the use case when an implementation has detected an Over Temperature Condition for Memory that has been Removed.

May also be shown as 816f0a0c200bfff or 0x816f0a0c200bfff

**Severity**

Info

**Serviceable**

No

**Automatically notify support**

No

**Alert Category**

Critical - Temperature

**SNMP Trap ID**

0

**CIM Information**

Prefix: PLAT ID: 0147

**User Response**

No action; information only.

- **816f0a0c-200cffff : An Over-Temperature Condition has been removed on the [PhysicalMemoryElementName] on Subsystem [MemoryElementName]. (DIMM 12)**

This message is for the use case when an implementation has detected an Over Temperature Condition for Memory that has been Removed.

May also be shown as 816f0a0c200cffff or 0x816f0a0c200cffff

**Severity**

Info

**Serviceable**

No

**Automatically notify support**

No

**Alert Category**

Critical - Temperature

**SNMP Trap ID**

0

**CIM Information**

Prefix: PLAT ID: 0147

**User Response**

No action; information only.

- **816f0a0c-200dffff : An Over-Temperature Condition has been removed on the [PhysicalMemoryElementName] on Subsystem [MemoryElementName]. (DIMM 13)**

This message is for the use case when an implementation has detected an Over Temperature Condition for Memory that has been Removed.

May also be shown as 816f0a0c200dffff or 0x816f0a0c200dffff

**Severity**

Info

**Serviceable**

No

**Automatically notify support**

No

**Alert Category**

Critical - Temperature

**SNMP Trap ID**

0

**CIM Information**

Prefix: PLAT ID: 0147

**User Response**

No action; information only.

- **816f0a0c-200effff : An Over-Temperature Condition has been removed on the [PhysicalMemoryElementName] on Subsystem [MemoryElementName]. (DIMM 14)**

This message is for the use case when an implementation has detected an Over Temperature Condition for Memory that has been Removed.

May also be shown as 816f0a0c200effff or 0x816f0a0c200effff

**Severity**

Info

**Serviceable**

No

**Automatically notify support**

No

**Alert Category**

Critical - Temperature

**SNMP Trap ID**

0

**CIM Information**

Prefix: PLAT ID: 0147

**User Response**

No action; information only.

- **816f0a0c-200fffff : An Over-Temperature Condition has been removed on the [PhysicalMemoryElementName] on Subsystem [MemoryElementName]. (DIMM 15)**

This message is for the use case when an implementation has detected an Over Temperature Condition for Memory that has been Removed.

May also be shown as 816f0a0c200fffff or 0x816f0a0c200fffff

**Severity**

Info

**Serviceable**

No

**Automatically notify support**

No

**Alert Category**

Critical - Temperature

**SNMP Trap ID**

0

**CIM Information**

Prefix: PLAT ID: 0147

**User Response**

No action; information only.

- **816f0a0c-2010ffff : An Over-Temperature Condition has been removed on the [PhysicalMemoryElementName] on Subsystem [MemoryElementName]. (DIMM 16)**

This message is for the use case when an implementation has detected an Over Temperature Condition for Memory that has been Removed.

May also be shown as 816f0a0c2010ffff or 0x816f0a0c2010ffff

**Severity**

Info

**Serviceable**

No

**Automatically notify support**

No

**Alert Category**

Critical - Temperature

**SNMP Trap ID**

0

**CIM Information****Prefix: PLAT ID:** 0147**User Response**

No action; information only.

- **816f0a0c-2011ffff : An Over-Temperature Condition has been removed on the [PhysicalMemoryElementName] on Subsystem [MemoryElementName]. (DIMM 17)**

This message is for the use case when an implementation has detected an Over Temperature Condition for Memory that has been Removed.

May also be shown as 816f0a0c2011ffff or 0x816f0a0c2011ffff

**Severity**

Info

**Serviceable**

No

**Automatically notify support**

No

**Alert Category**

Critical - Temperature

**SNMP Trap ID**

0

**CIM Information****Prefix: PLAT ID:** 0147**User Response**

No action; information only.

- **816f0a0c-2012ffff : An Over-Temperature Condition has been removed on the [PhysicalMemoryElementName] on Subsystem [MemoryElementName]. (DIMM 18)**

This message is for the use case when an implementation has detected an Over Temperature Condition for Memory that has been Removed.

May also be shown as 816f0a0c2012ffff or 0x816f0a0c2012ffff

**Severity**

Info

**Serviceable**

No

**Automatically notify support**

No

**Alert Category**

Critical - Temperature

**SNMP Trap ID**

0

**CIM Information**

**Prefix:** PLAT ID: 0147

**User Response**

No action; information only.

- **816f0a0c-2013ffff : An Over-Temperature Condition has been removed on the [PhysicalMemoryElementName] on Subsystem [MemoryElementName]. (DIMM 19)**

This message is for the use case when an implementation has detected an Over Temperature Condition for Memory that has been Removed.

May also be shown as 816f0a0c2013ffff or 0x816f0a0c2013ffff

**Severity**

Info

**Serviceable**

No

**Automatically notify support**

No

**Alert Category**

Critical - Temperature

**SNMP Trap ID**

0

**CIM Information**

**Prefix:** PLAT ID: 0147

**User Response**

No action; information only.

- **816f0a0c-2014ffff : An Over-Temperature Condition has been removed on the [PhysicalMemoryElementName] on Subsystem [MemoryElementName]. (DIMM 20)**

This message is for the use case when an implementation has detected an Over Temperature Condition for Memory that has been Removed.

May also be shown as 816f0a0c2014ffff or 0x816f0a0c2014ffff

**Severity**

Info

**Serviceable**

No

**Automatically notify support**

No

**Alert Category**

Critical - Temperature

**SNMP Trap ID**

0

**CIM Information**

**Prefix:** PLAT ID: 0147

**User Response**

No action; information only.

- **816f0a0c-2015ffff : An Over-Temperature Condition has been removed on the [PhysicalMemoryElementName] on Subsystem [MemoryElementName]. (DIMM 21)**

This message is for the use case when an implementation has detected an Over Temperature Condition for Memory that has been Removed.

May also be shown as 816f0a0c2015ffff or 0x816f0a0c2015ffff

**Severity**

Info

**Serviceable**

No

**Automatically notify support**

No

**Alert Category**

Critical - Temperature

**SNMP Trap ID**

0

**CIM Information**

Prefix: PLAT ID: 0147

**User Response**

No action; information only.

- **816f0a0c-2016ffff : An Over-Temperature Condition has been removed on the [PhysicalMemoryElementName] on Subsystem [MemoryElementName]. (DIMM 22)**

This message is for the use case when an implementation has detected an Over Temperature Condition for Memory that has been Removed.

May also be shown as 816f0a0c2016ffff or 0x816f0a0c2016ffff

**Severity**

Info

**Serviceable**

No

**Automatically notify support**

No

**Alert Category**

Critical - Temperature

**SNMP Trap ID**

0

**CIM Information**

Prefix: PLAT ID: 0147

**User Response**

No action; information only.

- **816f0a0c-2017ffff : An Over-Temperature Condition has been removed on the [PhysicalMemoryElementName] on Subsystem [MemoryElementName]. (DIMM 23)**

This message is for the use case when an implementation has detected an Over Temperature Condition for Memory that has been Removed.

May also be shown as 816f0a0c2017ffff or 0x816f0a0c2017ffff



**Severity**

Info

**Serviceable**

No

**Automatically notify support**

No

**Alert Category**

Critical - Temperature

**SNMP Trap ID**

0

**CIM Information****Prefix: PLAT ID:** 0147**User Response**

No action; information only.

- **816f0a0c-2018ffff : An Over-Temperature Condition has been removed on the [PhysicalMemoryElementName] on Subsystem [MemoryElementName]. (DIMM 24)**

This message is for the use case when an implementation has detected an Over Temperature Condition for Memory that has been Removed.

May also be shown as 816f0a0c2018ffff or 0x816f0a0c2018ffff

**Severity**

Info

**Serviceable**

No

**Automatically notify support**

No

**Alert Category**

Critical - Temperature

**SNMP Trap ID**

0

**CIM Information****Prefix: PLAT ID:** 0147**User Response**

No action; information only.

- **816f0a13-0301ffff : System [ComputerSystemElementName] has recovered from a Fatal Bus Error. (CPU 1 PECl)**

This message is for the use case when an implementation has detected that a system has recovered from a Bus Fatal Error.

May also be shown as 816f0a130301ffff or 0x816f0a130301ffff

**Severity**

Info

**Serviceable**

No

**Automatically notify support**

No

**Alert Category**

Critical - Other

**SNMP Trap ID**

50

**CIM Information**

**Prefix:** PLAT ID: 0245

**User Response**

1. (Trained technician only) Replace microprocessor n (see Removing a microprocessor and heat sink and Replacing a microprocessor and heat sink).
  2. If the problem persists and there is no other CPU with the same error indication, replace the system board.
  3. (Trained technician only) Replace the system board (see Removing the system board and Replacing the system board). (n = microprocessor number)
- **816f0a13-0302ffff : System [ComputerSystemElementName] has recovered from a Fatal Bus Error. (CPU 2 PECI)**

This message is for the use case when an implementation has detected that a system has recovered from a Bus Fatal Error.

May also be shown as 816f0a130302ffff or 0x816f0a130302ffff

**Severity**

Info

**Serviceable**

No

**Automatically notify support**

No

**Alert Category**

Critical - Other

**SNMP Trap ID**

50

**CIM Information**

**Prefix:** PLAT ID: 0245

**User Response**

1. (Trained technician only) Replace microprocessor n (see Removing a microprocessor and heat sink and Replacing a microprocessor and heat sink).
2. If the problem persists and there is no other CPU with the same error indication, replace the system board.
3. (Trained technician only) Replace the system board (see Removing the system board and Replacing the system board). (n = microprocessor number)

---

## Appendix B. UEFI/POST diagnostic codes

UEFI/POST diagnostic error codes can be generated when the server starts or while the server is running. UEFI/POST codes are logged in the IMM event log in the server.

For each event code, the following fields are displayed:

### Event identifier

An identifier that uniquely identifies an event.

### Event description

The logged message string that appears for an event.

### Explanation

Additional information to explain why the event occurred.

### Severity

An indication of the level of concern for the condition. The severity is abbreviated in the event log to the first character. The following severities can be displayed.

Table 21. Event severity levels

Severity	Description
Informational	An informational message is something that was recorded for audit purposes, usually a user action or a change of states that is normal behavior.
Warning	A warning is not as severe as an error, but if possible, the condition should be corrected before it becomes an error. It might also be a condition that requires additional monitoring or maintenance.
Error	An error typically indicates a failure or critical condition that impairs service or an expected function.

### User response

The actions that you should take to resolve the event.

Perform the steps in the order shown until the problem is solved. After you perform all of the actions that are described in this field, if you cannot solve the problem, contact Lenovo Support.

### Booting server to F1 setup menu

In addition to the normal process in booting the server to the F1 setup menu (pressing F1 when <F1 Set up> is displayed), there are two other ways for users to choose.

- Method 1

1. Proceed to the IMM2 website.
2. Select **Server Management** tab.
3. Select **Server Power Action**.
4. Select **Boot Server to F1 Setup**.

- Method 2

Use Advanced Settings Utility (ASU) program. Command line is shown as follows: **asu.exe set IMM.ForceBootToUefi enable**

**Attention:**

1. When you press Ctrl+Alt+Delete on F1 setup menu panel, the system will reboot automatically and ask you to enter password again.
2. Most F1 Setup settings, which can be load default, are chipset related items or less user input required items. However, when adjusting the iSCSI settings, be aware that the iSCSI configurations cannot be restored to default. This is to avoid iSCSI items losing its configurations, which may result in the system not being able to boot to the operating system.

The following is the list of the UEFI/POST error codes and suggested actions to correct the detected problems.

---

## List of UEFI events

This section lists all messages that can be sent from UEFI.

- **I.11002 A processor mismatch has been detected between one or more processors in the system. One or More Mismatched Processors Detected**

**Explanation:****Severity**

Error

**User Response**

Complete the following steps:

1. This message could occur with messages about other Processor configuration problems. Resolve those messages first.
  2. If the problem persists, ensure that matching processors are installed (i.e., matching option part numbers, etc)
  3. Verify that the Processor's are installed in the correct sockets according to the service information for this product. If not, correct that problem.
  4. Check IBM support site for an applicable service bulletin or UEFI firmware update that applies to this processor error.
  5. (Trained Service technician only) Replace mismatching processor. Inspect Processor socket and replace the system board first if socket is damaged.
- **I.1800A A mismatch has been detected between the speed at which a QPI link has trained between two or more processor packages. Processors have mismatched Bus Speed**

**Explanation:****Severity**

Error

**User Response**

Complete the following steps:

1. Verify that the processor is a valid option that is listed as a Server Proven device for this system. If not, remove the Processor and install one listed on the Server Proven website.
2. Verify that matching processors are installed in the correct processor sockets. Correct any mismatch found.
3. Check the IBM support site for an applicable service bulletin or firmware update that applies to this processor error.
4. (Trained Service technician only) Replace the Processor. Inspect Processor socket and replace the system board first if socket is damaged

- **I.1800C A cache type mismatch has been detected for one or more processor packages. Processors have one or more cache levels with mismatched type**

**Explanation:**

**Severity**

Error

**User Response**

Complete the following steps:

1. Verify that matching processors are installed in the correct processor sockets. Correct any mismatch found.
2. Check the IBM support site for an applicable service bulletin or firmware update that applies to this processor error.
3. (Trained technician only)Replace the system board

- **I.1800D A cache associativity mismatch has been detected for one or more processor packages. Processors have one or more cache levels with mismatched associativity**

**Explanation:**

**Severity**

Error

**User Response**

Complete the following steps:

1. Verify that matching processors are installed in the correct processor sockets. Correct any mismatch found.
2. Check the IBM support site for an applicable service bulletin or firmware update that applies to this processor error.
3. (Trained technician only)Replace the system board

- **I.1800E A processor model mismatch has been detected for one or more processor packages. Processors have mismatched Model Number**

**Explanation:**

**Severity**

Error

**User Response**

Complete the following steps:

1. Verify that matching processors are installed in the correct processor sockets. Correct any mismatch found.
2. Check the IBM support site for an applicable service bulletin or firmware update that applies to this Processor error.
3. (Trained technician only)Replace the system board

- **I.1800F A processor family mismatch has been detected for one or more processor packages. Processors have mismatched Family**

**Explanation:**

**Severity**

Error

**User Response**

Complete the following steps:

1. Verify that matching processors are installed in the correct processor sockets. Correct any mismatch found.
2. Check the IBM support site for an applicable service bulletin or firmware update that applies to this processor error.
3. (Trained technician only) Replace the system board

- **I.18010 A processor stepping mismatch has been detected for one or more processor packages. Processors of the same model have mismatched Stepping ID**

**Explanation:**

**Severity**

Error

**User Response**

Complete the following steps:

1. Verify that matching processors are installed in the correct processor sockets. Correct any mismatch found.
  2. Check the IBM support site for an applicable service bulletin or firmware update that applies to this processor error.
  3. (Trained technician only) Replace the system board
- **I.2018002 The device found at Bus [arg1] Device [arg2] Function [arg3] could not be configured due to resource constraints. The Vendor ID for the device is [arg4] and the Device ID is [arg5]. OUT\_OF\_RESOURCES (PCI Option ROM)**

**Explanation:**

**Severity**

Info

**User Response**

Complete the following steps:

1. If this PCIe device and/or any attached cables were recently installed, moved, serviced or upgraded, reseal the adapter and any attached cables.
  2. Check IBM support site for any applicable service bulletin or UEFI or adapter firmware update that applies to this error. NOTE: It may be necessary to disable unused option ROMs from UEFI F1 setup or ToolsCenter Suite CLI or using adapter manufacturer utilities so that adapter firmware can be updated.
  3. Move the adapter to a different slot. If a slot is not available or error recurs, replace the adapter.
  4. If the adapter was moved to a different slot and the error did not recur, verify that this is not a system limitation. Then replace the system board. Also, if this is not the initial installation and the error persists after adapter replacement, replace the system board.
- **I.2018003 A bad option ROM checksum was detected for the device found at Bus [arg1] Device [arg2] Function [arg3]. The Vendor ID for the device is [arg4] and the Device ID is [arg5]. ROM CHECKSUM ERROR**

**Explanation:**

**Severity**

Error

**User Response**

Complete the following steps:

1. If this PCIe device and/or any attached cables were recently installed, moved, serviced or upgraded, reseal the adapter and any attached cables.

2. Move the adapter to a different system slot, if available.
3. Check IBM support site for any applicable service bulletin or UEFI or adapter firmware update that applies to this error. NOTE: It may be necessary to configure slot to Gen1 or to use special utility software so that adapter firmware can be upgraded. Gen1/Gen2 settings can be configured via F1 Setup -> System Settings -> Devices and I/O Ports -> PCIe Gen1/Gen2/Gen3 Speed Selection, or the ToolsCenter Suite CLI Utility.
4. Replace the adapter.

- **I.3808004 The IMM System Event log (SEL) is full. IPMI System Event Log is Full**

**Explanation:**

**Severity**

Info

**User Response**

Complete the following steps:

1. Use the IMM Web Interface to clear the event log.
2. If IMM communication is unavailable, use F1 Setup to access System Event Logs Menu and Choose Clear IMM System Event Log and Restart Server.

- **I.3818001 The firmware image capsule signature for the currently booted flash bank is invalid. Current Bank CRTM Capsule Update Signature Invalid**

**Explanation:**

**Severity**

Info

**User Response**

Complete the following steps:

1. Reboot the system. Will come up on backup UEFI image. Update the primary UEFI image.
2. If error does not persist no additional recovery action is required.
3. If error persists, or boot is unsuccessful, (Trained service technician only) Replace the system board.

- **I.3818002 The firmware image capsule signature for the non-booted flash bank is invalid. Opposite Bank CRTM Capsule Update Signature Invalid**

**Explanation:**

**Severity**

Info

**User Response**

Complete the following steps:

1. Update the backup UEFI image.
2. If error does not persist no additional recovery action is required.
3. If error persists, or boot is unsuccessful, (Trained service technician only) Replace the system board.

- **I.3818003 The CRTM flash driver could not lock the secure flash region. CRTM Could not lock secure flash region**

**Explanation:**

**Severity**

Info

**User Response**

Complete the following steps:

1. If system failed to boot successfully, DC cycle the system.
2. If system boots to F1 setup, update the UEFI image and reset bank to primary (if required). If the system boots without error, recovery is complete and no additional action is required.
3. If system fails to boot, or if the firmware update attempt fails, (trained service technician only) replace the system board.

- **I.3818009 The TPM could not be properly initialized. TPMINIT: Fail to initialize TPM chip.**

**Explanation:**

**Severity**

Info

**User Response**

Complete the following steps:

1. Check the IBM support site for an applicable service bulletin or firmware update that applies to this error.
2. Reboot the system.
3. If the error continues, replace the system-board assembly (see Removing the system-board assembly and Installing the system-board assembly).

- **I.3868000 IFM: System reset performed to reset adapters. IFM: System reset performed to reset adapters**

**Explanation:**

**Severity**

Info

**User Response**

Complete the following steps:

1. Information only; no action is required.

- **I.3868003 IFM: Configuration too large for compatibility mode. IFM: Configuration too large for compatibility mode**

**Explanation:**

**Severity**

Info

**User Response**

Complete the following steps:

1. Information only; no action is required.

- **I.5100B An unqualified DIMM serial number has been detected: serial number [arg1] found in slot [arg2] of memory card [arg3]. Unqualified DIMM Serial Number Detected**

**Explanation:**

**Severity**

Info

**User Response**

Complete the following steps:

1. If this information event is logged in the IMM event log, the server does not have qualified memory installed.
2. The memory installed may not be covered under warranty.
3. Without qualified memory, speeds supported above industry standards will not be enabled.



4. Please contact your Local Sales Representative or Authorized Business Partner to order qualified memory to replace the unqualified DIMM(s).
5. After you install qualified memory and power up the server, check to make sure this informational event is not logged again.

- **I.58015 Memory spare copy initiated. Spare Copy Started**

**Explanation:**

**Severity**

Info

**User Response**

Complete the following steps:

1. Information only; no action is required.

- **I.580A4 Memory population change detected. DIMM Population Change Detected**

**Explanation:**

**Severity**

Info

**User Response**

Complete the following steps:

1. If you have added or removed DIMMs to the system, and no additional errors were detected, then please ignore this message.
2. Check system event log for uncorrected DIMM failures and replace those DIMMs.

- **I.580A5 Mirror Fail-over complete. DIMM number [arg1] has failed over to to the mirrored copy. DIMM Mirror Fail-over Detected**

**Explanation:**

**Severity**

Info

**User Response**

Complete the following steps:

1. Check the system-event log for uncorrected DIMM failures and replace those DIMMs.

- **I.580A6 Memory spare copy has completed successfully. Spare Copy Complete**

**Explanation:**

**Severity**

Info

**User Response**

Complete the following steps:

1. If you have added or removed DIMMs to the system, and no additional errors were detected, then please ignore this message.
2. Check system event log for uncorrected DIMM failures and replace those DIMMs.

- **S.1100B CATERR(IERR) has asserted on processor [arg1]. Processor CATERR(IERR) has asserted**

**Explanation:**

**Severity**

Error

**User Response**

Complete the following steps:

1. Check IBM support site for an applicable service bulletin or UEFI firmware update that applies to this Processor error.
  2. (Trained service technician only) If there are multiple Processor's, swap Processor's to move affected Processor to another Processor socket and retry. If problem follows the affected Processor, or this is a single Processor system, replace the Processor.
  3. (Trained Service technician only) Inspect Processor socket on each Processor removal and replace system board first if damaged or mis-aligned pins are found. Replace the system board.
- **S.1100C An uncorrectable error has been detected on processor [arg1]. Uncorrectable processor error detected**

**Explanation:**

**Severity**

Error

**User Response**

Complete the following steps:

1. Check the IBM support site for an applicable service bulletin or firmware update that applies to this error.
  2. (Trained service technician only) If there are multiple Processor's, swap Processor's to move affected Processor to another Processor socket and retry. If problem follows the affected Processor, or this is a single Processor system, replace the Processor.
  3. (Trained Service technician only) Inspect Processor socket on each Processor removal and replace system board first if damaged or mis-aligned pins are found. Replace the system board.
- **S.2011001 An Uncorrected PCIe Error has Occurred at Bus [arg1] Device [arg2] Function [arg3]. The Vendor ID for the device is [arg4] and the Device ID is [arg5]. PCI SERR Detected**

**Explanation:**

**Severity**

Error

**User Response**

Complete the following steps:

1. Check IBM support site for an applicable device driver, firmware update, version of service information for this product or other information that applies to this error. Load new device driver and any required firmware updates.
  2. If this node and/or any attached cables were recently installed, moved, serviced or upgraded, a. Reseat Adapter and any attached cables. b. Reload Device Driver c. If device is not recognized, reconfiguring slot to Gen1 or Gen2 may be required. Gen1/Gen2 settings can be configured via F1 Setup -> System Settings -> Devices and I/O Ports -> PCIe Gen1/Gen2/Gen3 Speed Selection, or the ToolsCenter Suite CLI Utility.
  3. If problem persists, then remove Adapter Card. If system reboots successfully without the adapter, replace that card.
  4. (Trained Service technician only) Replace the system board.
  5. (Trained Service technician only) Replace the processor.
- **S.2018001 An Uncorrected PCIe Error has Occurred at Bus [arg1] Device [arg2] Function [arg3]. The Vendor ID for the device is [arg4] and the Device ID is [arg5]. PCIe Uncorrected Error Detected**

**Explanation:**

**Severity**

Error

**User Response**

Complete the following steps:

1. Check IBM support site for an applicable device driver, firmware update, version of service information for this product or other information that applies to this error. Load new device driver and any required firmware updates.
  2. If this node and/or any attached cables were recently installed, moved, serviced or upgraded, a. Reseat Adapter and any attached cables. b. Reload Device Driver c. If device is not recognized, reconfiguring slot to Gen1 or Gen2 may be required. Gen1/Gen2 settings can be configured via F1 Setup -> System Settings -> Devices and I/O Ports -> PCIe Gen1/Gen2/Gen3 Speed Selection, or the ToolsCenter Suite CLI Utility.
  3. If problem persists, then remove Adapter Card. If system reboots successfully without the adapter, replace that card.
  4. (Trained Service technician only) Replace the system board.
  5. (Trained Service technician only) Replace the processor.
- **S.3020007 A firmware fault has been detected in the UEFI image. Internal UEFI Firmware Fault Detected, System halted**

**Explanation:**

**Severity**

Error

**User Response**

Complete the following steps:

1. Check the IBM support site for an applicable service bulletin or firmware update that applies to this error.
  2. Update the UEFI image.
  3. (Trained service technician only) Replace the system board.
- **S.3028002 Boot permission timeout detected. Boot Permission Negotiation Timeout**

**Explanation:**

**Severity**

Error

**User Response**

Complete the following steps:

1. Check CMM/IMM logs for communication errors and resolve.
  2. Reseat the system
  3. If problem persists contact support
- **S.3030007 A firmware fault has been detected in the UEFI image. Internal UEFI Firmware Fault Detected, System halted**

**Explanation:**

**Severity**

Error

**User Response**

Complete the following steps:

1. Check IBM support site for an applicable service bulletin or firmware update that applies to this error.
2. Update the UEFI image.
3. Replace the system board.

- **S.3040007 A firmware fault has been detected in the UEFI image. Internal UEFI Firmware Fault Detected, System halted**

**Explanation:**

**Severity**

Error

**User Response**

Complete the following steps:

1. Check IBM support site for an applicable service bulletin or firmware update that applies to this error.
2. Update the UEFI image.
3. Replace the system board.

- **S.3050007 A firmware fault has been detected in the UEFI image. Internal UEFI Firmware Fault Detected, System halted**

**Explanation:**

**Severity**

Error

**User Response**

Complete the following steps:

1. Check IBM support site for an applicable service bulletin or firmware update that applies to this error.
2. Update the UEFI image.
3. Replace the system board.

- **S.3058004 A Three Strike boot failure has occurred. The system has booted with default UEFI settings. POST failure has occurred! System booted with default settings.**

**Explanation:**

**Severity**

Error

**User Response**

Complete the following steps:

1. This event resets UEFI to the default settings for the next boot. If successful, the Setup Utility is displayed. The original UEFI settings are still present.
2. If you did not intentionally trigger the reboots, check logs for probable cause.
3. Undo recent system changes (settings or devices added). If there were no recent system changes, remove all options, and then remove the CMOS battery for 30 seconds to clear CMOS contents. Verify that the system boots. Then, re-install the options one at a time to locate the problem.
4. Check the IBM support site for an applicable service bulletin or firmware update that applies to this error.
5. Update the UEFI firmware.
6. Remove and re-install CMOS battery for 30 seconds to clear CMOS contents.
7. (Trained service technician only) Replace the system board.

- **S.3060007 A firmware fault has been detected in the UEFI image. Internal UEFI Firmware Fault Detected, System halted**

**Explanation:**

**Severity**

Error

**User Response**

Complete the following steps:

1. Check IBM support site for an applicable service bulletin or firmware update that applies to this error.
  2. Update the UEFI image.
  3. Replace the system board.
- **S.3070007 A firmware fault has been detected in the UEFI image. Internal UEFI Firmware Fault Detected, System halted**

**Explanation:****Severity**

Error

**User Response**

Complete the following steps:

1. Check IBM support site for an applicable service bulletin or firmware update that applies to this error.
  2. Update the UEFI image.
  3. Replace the system board.
- **S.3108007 The default system settings have been restored. System Configuration Restored to Defaults**

**Explanation:****Severity**

Error

**User Response**

Complete the following steps:

1. Check IBM support site for an applicable service bulletin or firmware update that applies to this error.
- **S.3818004 The CRTM flash driver could not successfully flash the staging area. A failure occurred. CRTM Update Failed**

**Explanation:****Severity**

Error

**User Response**

Complete the following steps:

1. Continue booting the system. If the system does not reset, manually reset the system.
  2. If the error is not reported on the subsequent boot, no additional recovery action is required.
  3. If the error persists, continue booting system and update the UEFI image.
  4. (Trained service technician only) Replace the system board.
- **S.3818007 The firmware image capsules for both flash banks could not be verified. CRTM image capsule could not be verified**

**Explanation:****Severity**

Error

### User Response

Complete the following steps:

1. If system failed to boot successfully, DC cycle system.
  2. If system boots to F1 setup, update the UEFI image and reset bank to primary (if required). If the system boots without error, recovery is complete and no additional action is required.
  3. If system fails to boot, or if the firmware update attempt fails, (trained service technician only) replace the system board.
- **S.51003 An uncorrectable memory error was detected in DIMM slot [arg1] on rank [arg2]. An uncorrectable memory error was detected on processor [arg3] channel [arg4]. The failing DIMM within the channel could not be determined. An uncorrectable memory error has been detected. Fatal Memory Error Occurred**

### Explanation:

### Severity

Error

### User Response

Complete the following steps:

1. Check IBM support site for an applicable service bulletin or firmware update that applies to this memory error.
  2. If the node has recently been installed, moved, serviced, or upgraded, verify that the DIMM is properly seated and visually verify that there is no foreign material in any DIMM connector on that memory channel. If either of these conditions is found, correct and retry with the same DIMM. (Note: Event Log may contain a recent 580A4 event denoting detected change in DIMM population that could be related to this problem.)
  3. If no problem is observed on the DIMM connectors and the problem persists, replace the DIMM identified by LightPath and/or event log entry.
  4. If problem re-occurs on the same DIMM connector, swap the other DIMMs on the same memory channel across channels one at a time to a different memory channel or Processor. (check service information for this product/Install guide for population requirements for sparing/paring modes). If problem follows a moved DIMM to a different memory channel, replace that DIMM.
  5. (Trained service technician only) Remove affected Processor and inspect Processor socket pins for damaged or mis-aligned pins. If damage is found, or this is an upgrade Processor, replace the system board. If there are multiple Processor's, swap Processor's to move affected Processor to another Processor socket and retry. If problem follows the affected Processor (or there is only one Processor), replace the affected Processor.
  6. (Trained technician only)If problem stays with the original DIMM connector, re-inspect DIMM connector for foreign material and remove, if found. If connector is damaged, replace system board
- **S.51006 A memory mismatch has been detected. Please verify that the memory configuration is valid. One or More Mismatched DIMMs Detected**

### Explanation:

### Severity

Error

### User Response

Complete the following steps:

1. Could follow an uncorrectable memory error or failed memory test. Check the log and service that event first. DIMMs disabled by other errors or actions could cause this event.
2. Verify that the DIMMs are installed in the correct population sequence.

3. Disable memory mirroring and sparing. If this action eliminates the mismatch, check the IBM Support site for information related to this problem.
4. Update UEFI firmware.
5. Replace the DIMM.
6. Replace the processor.

- **S.51009 No system memory has been detected. No Memory Detected**

**Explanation:**

**Severity**

Error

**User Response**

Complete the following steps:

1. If any memory errors are logged other than this one, take actions indicated for those codes first.
2. If no other memory diagnostic codes appear in the logs, verify that all DIMM connectors are enabled using the Setup utility or the ToolsCenter Suite CLI.
3. If the problem remains, shut down and remove node from chassis and physically verify that one or more DIMMs are installed and that all DIMMs are installed in the correct population sequence.
4. If DIMMs are present and properly installed, check for any lit DIMM-connector LEDs, and if found, reseat those DIMMs.
5. Reinstall node in chassis, power on node, then check logs for memory diagnostic codes.
6. (Trained technician only) If the problem remains, replace the processor.
7. (Trained technician only) If the problem remains, replace the system board.

- **S.58008 A DIMM has failed the POST memory test. DIMM Failed Memory Test**

**Explanation:**

**Severity**

Error

**User Response**

Complete the following steps:

1. You must AC-cycle the system to re-enable the affected DIMM connector or re-enable manually using the Setup utility.
2. If the compute node has been recently installed, serviced, moved, or upgraded, check to ensure that DIMMs are firmly seated and that no foreign material can be seen in the DIMM connector. If either condition is observed, correct and retry with the same DIMM. (Note: The event Log might contain a recent 00580A4 event denoting detected change in DIMM population that could be related to this problem.)
3. If problem persists, replace the DIMM identified by LightPath and/or event log entry.
4. If problem recurs on the same DIMM connector, swap the other DIMMs on the same memory channel across channels one at a time to a different memory channel or processor. If problem follows a moved DIMM to a different memory channel, replace that DIMM.
5. Check the IBM support site for an applicable service bulletin or firmware update that applies to this memory error.
6. (Trained service technician only) Remove affected Processor and inspect Processor socket pins for damaged or mis-aligned pins. If damage is found, or this is an upgrade Processor, replace the system board. If there are multiple Processor's, swap Processor's to move affected Processor to another Processor socket and retry. If problem follows the affected Processor (or there is only one Processor), replace the affected Processor.

7. If problem stays with the original DIMM connector, re-inspect DIMM connector for foreign material and remove, if found. If connector is damaged, replace system board
- **S.68005 An error has been detected by the the IIO core logic on Bus [arg1]. The Global Fatal Error Status register contains [arg2]. The Global Non-Fatal Error Status register contains [arg3]. Please check error logs for the presence of additional downstream device error data. Critical IOH-PCI Error**

**Explanation:**

**Severity**

Error

**User Response**

Complete the following steps:

1. Check the log for a separate error related to an associated PCIe device and resolve that error.
  2. Check the IBM support site for an applicable service bulletin or firmware update for the system or adapter that applies to this error.
  3. Replace the I/O device or PCIe adapter
  4. (Trained technician only) Replace the system board reported in the error.
- **S.680B8 Internal QPI Link Failure Detected. Internal QPI Link Failure Detected**

**Explanation:**

**Severity**

Error

**User Response**

Complete the following steps:

1. Check the IBM support site for an applicable service bulletin or firmware update that applies to this error.
  2. Inspect the processor socket for foreign debris or damage. If debris is found, remove the debris.
  3. (Trained technician only) If error recurs, or socket damage is found, replace the system board
  4. (Trained Service Technician Only) Replace the processor.
- **S.680B9 External QPI Link Failure Detected. External QPI Link Failure Detected**

**Explanation:**

**Severity**

Error

**User Response**

Complete the following steps:

1. Check the IBM support site for an applicable service bulletin or firmware update that applies to this error.
  2. Inspect the processor socket for foreign debris or damage. If debris is found, remove the debris.
  3. (Trained technician only) If error recurs, or socket damage is found, replace the system board
- **W.11004 A processor within the system has failed the BIST. Processor Self Test Failure Detected**

**Explanation:**

**Severity**

Error

**User Response**

Complete the following steps:



1. If the processor or firmware was just updated, check the IBM support site for an applicable service bulletin or firmware update that applies to this processor error.
  2. (Trained service technician only) If there are multiple Processor's, swap Processor's to move affected Processor to another Processor socket and retry. If problem follows the affected Processor, or this is a single Processor processor. Inspect the processor socket on each processor removal and replace system board first if the processor socket is damaged or mis-aligned pins are found.
  3. (Trained Service technician only) Inspect Processor socket on each Processor removal and replace system board first if damaged or mis-aligned pins are found. Replace the system board.
- **W.3048006 UEFI has booted from the backup flash bank due to an Automatic Boot Recovery (ABR) event. Automated Boot Recovery, Booting Backup UEFI Image**

**Explanation:**

**Severity**

Warning

**User Response**

Complete the following steps:

1. Check the IBM support site for an applicable service bulletin or firmware update that applies to this error.
2. Update the primary UEFI image.
3. Replace the system board.

- **W.305000A An invalid date and time have been detected. RTC Date and Time Incorrect**

**Explanation:**

**Severity**

Warning

**User Response**

Complete the following steps:

1. Check IMM/chassis event log. This event should immediately precede 0068002 error. Resolve that event or any other battery related errors.
2. Use F1 Setup to reset date and time. If problem returns after a system reset, replace CMOS battery.
3. If problem persists then check IBM support site for an applicable service bulletin or firmware update that applies to this error.
4. (Trained service technician only) Replace the system board.

- **W.3058009 DRIVER HEALTH PROTOCOL: Missing Configuration. Requires Change Settings From F1. DRIVER HEALTH PROTOCOL: Missing Configuration. Requires Change Settings From F1**

**Explanation:**

**Severity**

Warning

**User Response**

Complete the following steps:

1. Go to F1 Setup > System Settings > Settings > Driver Health Status List and find a driver/controller reporting Configuration Required status.
2. Search for the driver menu from System Settings and change settings appropriately.
3. Save settings and restart system.

- **W.305800A DRIVER HEALTH PROTOCOL: Reports 'Failed' Status Controller. DRIVER HEALTH PROTOCOL: Reports 'Failed' Status Controller**

**Explanation:**

**Severity**

Warning

**User Response**

Complete the following steps:

1. Reboot the system.
2. If problem persists, switch to backup UEFI or update the current UEFI image.
3. Replace the system board.

- **W.305800B DRIVER HEALTH PROTOCOL: Reports 'Reboot' Required Controller. DRIVER HEALTH PROTOCOL: Reports 'Reboot' Required Controller**

**Explanation:**

**Severity**

Warning

**User Response**

Complete the following steps:

1. No action required. The system will reboot at the end of POST.
2. If the problem persists, switch to the backup UEFI image or update the current UEFI image.
3. Replace the system board.

- **W.305800C DRIVER HEALTH PROTOCOL: Reports 'System Shutdown' Required Controller. DRIVER HEALTH PROTOCOL: Reports 'System Shutdown' Required Controller**

**Explanation:**

**Severity**

Warning

**User Response**

Complete the following steps:

1. No action required. The system will reboot at the end of POST.
2. If the problem persists, switch to the backup UEFI image or update the current UEFI image.
3. Replace the system board.

- **W.305800D DRIVER HEALTH PROTOCOL: Disconnect Controller Failed. Requires 'Reboot'. DRIVER HEALTH PROTOCOL: Disconnect Controller Failed. Requires 'Reboot'**

**Explanation:**

**Severity**

Warning

**User Response**

Complete the following steps:

1. No action required. The system will reboot at the end of POST.
2. If the problem persists, switch to the backup UEFI image or update the current UEFI image.
3. Replace the system board.

- **W.305800E DRIVER HEALTH PROTOCOL: Reports Invalid Health Status Driver. DRIVER HEALTH PROTOCOL: Reports Invalid Health Status Driver**

**Explanation:**

**Severity**

Warning

**User Response**

Complete the following steps:

1. No action required. The system will reboot at the end of POST.
2. If the problem persists, switch to the backup UEFI image or update the current UEFI image.
3. Replace the system board.

- **W.3808000 An IMM communication failure has occurred. IMM Communication Failure**

**Explanation:****Severity**

Warning

**User Response**

Complete the following steps:

1. Reset the IMM from the CMM.
2. Use the CMM to remove auxiliary power from the compute node. This will reboot the compute node.
3. Check the IBM support site for an applicable service bulletin or firmware update that applies to this error.
4. Update the UEFI Firmware.
5. (Trained service technician only) Replace the system board.

- **W.3808002 An error occurred while saving UEFI settings to the IMM. Error Updating System Configuration to IMM**

**Explanation:****Severity**

Warning

**User Response**

Complete the following steps:

1. Use the Setup Utility to verify and save the settings (which will recover the settings).
2. Reset the IMM from the CMM.
3. Use CMM to remove auxiliary power from the compute node. This will reboot the compute node.
4. Check the IBM support site for an applicable service bulletin or firmware update that applies to this error.
5. Update the IMM Firmware.
6. Use CMOS clear jumper to clear CMOS
7. (Trained service technician only) Replace the system board.

- **W.3808003 Unable to retrieve the system configuration from the IMM. Error Retrieving System Configuration from IMM**

**Explanation:****Severity**

Warning

**User Response**

Complete the following steps:

1. Use the Setup Utility to verify and save the settings (which will recover the settings).

2. Reset the IMM from the CMM.
3. Use CMM to remove auxiliary power from the compute node. This will reboot the compute node.
4. Check the IBM support site for an applicable service bulletin or firmware update that applies to this error.
5. Update the IMM Firmware.
6. Use CMOS clear jumper to clear CMOS
7. (Trained service technician only) Replace the system board.

- **W.3818005 The CRTM flash driver could not successfully flash the staging area. The update was aborted CRTM Update Aborted**

**Explanation:**

**Severity**

Warning

**User Response**

Complete the following steps:

1. Continue booting the system. If system does not reset, manually reset the system.
2. If the error is not reported on the subsequent boot, no additional recovery action is required.
3. If the event persists, continue booting system and update the UEFI image.
4. (Trained service technician only) Replace the system board.

- **W.3868001 IFM: Reset loop avoided - Multiple resets not allowed. IFM: Reset loop avoided - Multiple resets not allowed**

**Explanation:**

**Severity**

Warning

**User Response**

Complete the following steps:

1. Update all firmware (including adapter firmware) to the latest levels.
  2. If problem persists escalate to the next level of support.
- **W.3868002 IFM: Error communicating with the IMM - IFM may not be deployed correctly. IFM: Error communicating with the IMM - IFM may not be deployed correctly**

**Explanation:**

**Severity**

Error

**User Response**

Complete the following steps:

1. Update all firmware (including adapter firmware) to the latest levels.
  2. If problem persists escalate to the next level of support.
- **W.3938002 A boot configuration error has been detected. Boot Configuration Error**

**Explanation:**

**Severity**

Warning

**User Response**

Complete the following steps:

1. F1 Setup -> Save Settings.
2. Retry OOB configuration update.

- **W.50001 A DIMM has been disabled due to an error detected during POST. DIMM Disabled**

**Explanation:**

**Severity**

Info

**User Response**

Complete the following steps:

1. If the DIMM was disabled because of a memory fault, follow the procedure for that event.
2. If no memory fault is recorded in the logs and no DIMM connector error LEDs are lit, re-enable the DIMM through the Setup utility or the ToolsCenter Suite CLI.
3. If the problem persists, Power cycle the compute node from the management console.
4. Reset the IMM to default settings.
5. Reset UEFI to default settings.
6. Update IMM and UEFI firmware.
7. Swap/reseat the DIMM from the disabled slot with a matching DIMM. If the slot remains disabled, (trained technician only) replace system board

- **W.58001 The PFA Threshold limit (correctable error logging limit) has been exceeded on DIMM number [arg1] at address [arg2]. MC5 Status contains [arg3] and MC5 Misc contains [arg4]. DIMM PFA Threshold Exceeded**

**Explanation:**

**Severity**

Error

**User Response**

Complete the following steps:

1. If the compute node has recently been installed, moved, serviced, or upgraded, verify that the DIMM is properly seated and visually verify that there is no foreign material in any DIMM connector on that memory channel. If either of these conditions is found, correct and retry with the same DIMM. (Note: The event Log might contain a recent 580A4 event denoting detected change in DIMM population that could be related to this problem.)
2. Check the IBM support site for an applicable firmware update that applies to this memory error. The release notes will list the known problems the update addresses.
3. If the previous steps do not resolve the problem, at the next maintenance opportunity, swap the DIMMs on the same memory channel one at a time to a different memory channel or Processor. (check service information for this product/Install guide for population requirements for sparing/paring modes). If PFA follows a moved DIMM to any DIMM connector on the different memory channel, replace the moved DIMM.
4. If no problem is observed on the DIMM connectors and the problem persists, replace the DIMM identified by LightPath and/or event log entry.
5. If problem re-occurs on the same DIMM connector, swap the other DIMMs on the same memory channel across channels one at a time to a different memory channel or Processor. (check service information for this product/Install guide for population requirements for sparing/paring modes). If problem follows a moved DIMM to a different memory channel, replace that DIMM.
6. (Trained service technician only) Remove affected Processor and inspect Processor socket pins for damaged or mis-aligned pins. If damage is found, or this is an upgrade Processor, replace the system board. If there are multiple Processor's, swap Processor's to move affected Processor to

another Processor socket and retry. If problem follows the affected Processor (or there is only one Processor), replace the affected Processor.

7. (Trained technician only) If problem stays with the original DIMM connector, re-inspect DIMM connector for foreign material and remove, if found. If connector is damaged, replace system board

- **W.58007 Invalid memory configuration (Unsupported DIMM Population) detected. Please verify memory configuration is valid. Unsupported DIMM Population**

**Explanation:**

**Severity**

Error

**User Response**

Complete the following steps:

1. Ensure that the DIMM connectors are populated according to the guidelines in the service information for this product.
2. Ensure all DIMMs are enabled in the uEFI setup menu.
3. If a DIMM connector error LED is lit, resolve the failure.

- **W.580A1 Invalid memory configuration for Mirror Mode. Please correct memory configuration. Unsupported DIMM Population for Mirror Mode**

**Explanation:**

**Severity**

Error

**User Response**

Complete the following steps:

1. If a DIMM connector error LED is lit, resolve the failure.
2. Make sure that the DIMM connectors are correctly populated for mirroring mode.

- **W.580A2 Invalid memory configuration for Sparing Mode. Please correct memory configuration. Unsupported DIMM Population for Spare Mode**

**Explanation:**

**Severity**

Error

**User Response**

Complete the following steps:

1. If a DIMM connector error LED is lit, resolve the failure.
2. Make sure that the DIMM connectors are correctly populated for sparing mode, according to the service information for this product.

- **W.68002 A CMOS battery error has been detected CMOS Battery Fault**

**Explanation:**

**Severity**

Error

**User Response**

Complete the following steps:

1. If the system was recently installed, moved, or serviced, make sure the battery is properly seated.

2. Check the IBM support site for an applicable service bulletin or firmware update that applies to this error.
3. Replace the CMOS battery.
4. (Trained technician only) Replace the system board





---

## Appendix C. DSA diagnostic test results

After running the DSA diagnostic tests, use this information to resolve any issues that were found.

---

### DSA Broadcom network test results

The following messages can result when you run the Broadcom network test.

#### Test results for the DSA Broadcom network test

The following messages can result when you run the DSA Broadcom network test.

- **405-000-000 : BRCM:TestControlRegisters Test Passed**

The test passed.

**Recoverable**

No

**Severity**

Event

**Serviceable**

No

**Automatically notify support**

No

**Related links**

- [IBM Support website](#)
- [Latest level of DSA](#)
- [Latest level of BMC/IMM](#)

- **405-001-000 : BRCM:TestMIIRegisters Test Passed**

The test passed.

**Recoverable**

No

**Severity**

Event

**Serviceable**

No

**Automatically notify support**

No

**Related links**

- [IBM Support website](#)
- [Latest level of DSA](#)
- [Latest level of BMC/IMM](#)

- **405-002-000 : BRCM:TestEEPROM Test Passed**

The test passed.

**Recoverable**

No

**Severity**

Event

**Serviceable**

No

**Automatically notify support**

No

**Related links**

- [IBM Support website](#)
- [Latest level of DSA](#)
- [Latest level of BMC/IMM](#)

- **405-003-000 : BRCM:TestInternalMemory Test Passed**

The test passed.

**Recoverable**

No

**Severity**

Event

**Serviceable**

No

**Automatically notify support**

No

**Related links**

- [IBM Support website](#)
- [Latest level of DSA](#)
- [Latest level of BMC/IMM](#)

- **405-004-000 : BRCM:TestInterrupt Test Passed**

The test passed.

**Recoverable**

No

**Severity**

Event

**Serviceable**

No

**Automatically notify support**

No

**Related links**

- [IBM Support website](#)
- [Latest level of DSA](#)
- [Latest level of BMC/IMM](#)

- **405-005-000 : BRCM:TestLoopbackMAC Test Passed**

The test passed.

**Recoverable**

No

**Severity**

Event

**Serviceable**

No

**Automatically notify support**

No

**Related links**

- [IBM Support website](#)
- [Latest level of DSA](#)
- [Latest level of BMC/IMM](#)

• **405-006-000 : BRCM:TestLoopbackPhysical Test Passed**

The test passed.

**Recoverable**

No

**Severity**

Event

**Serviceable**

No

**Automatically notify support**

No

**Related links**

- [IBM Support website](#)
- [Latest level of DSA](#)
- [Latest level of BMC/IMM](#)

• **405-007-000 : BRCM:TestLEDs Test Passed**

The test passed.

**Recoverable**

No

**Severity**

Event

**Serviceable**

No

**Automatically notify support**

No

**Related links**

- [IBM Support website](#)
- [Latest level of DSA](#)
- [Latest level of BMC/IMM](#)

• **405-800-000 : BRCM:TestControlRegisters Test Aborted**

The control registers test was canceled.

**Recoverable**

No

**Severity**

Warning

**Serviceable**

No

**Automatically notify support**

No

**Related links**

- [IBM Support website](#)
- [Latest level of DSA](#)
- [Latest level of BMC/IMM](#)

- **405-801-000 : BRCM:TestMIRegisters Test Aborted**

The MII register test was canceled.

**Recoverable**

No

**Severity**

Warning

**Serviceable**

No

**Automatically notify support**

No

**Related links**

- [IBM Support website](#)
- [Latest level of DSA](#)
- [Latest level of BMC/IMM](#)

- **405-802-000 : BRCM:TestEEPROM Test Aborted**

The EEPROM test was canceled.

**Recoverable**

No

**Severity**

Warning

**Serviceable**

No

**Automatically notify support**

No

**Related links**

- [IBM Support website](#)
- [Latest level of DSA](#)
- [Latest level of BMC/IMM](#)

- **405-803-000 : BRCM:TestInternalMemory Test Aborted**

The internal memory test was canceled.

**Recoverable**

No

**Severity**

Warning

**Serviceable**

No

**Automatically notify support**

No

**Related links**

- [IBM Support website](#)
- [Latest level of DSA](#)
- [Latest level of BMC/IMM](#)

- **405-804-000 : BRCM:TestInterrupt Test Aborted**

The interrupt test was canceled.

**Recoverable**

No

**Severity**

Warning

**Serviceable**

No

**Automatically notify support**

No

**Related links**

- [IBM Support website](#)
- [Latest level of DSA](#)
- [Latest level of BMC/IMM](#)

- **405-805-000 : BRCM:TestLoopbackMAC Test Aborted**

Loopback testing at the MAC layer was canceled.

**Recoverable**

No

**Severity**

Warning

**Serviceable**

No

**Automatically notify support**

No

**Related links**

- [IBM Support website](#)
- [Latest level of DSA](#)
- [Latest level of BMC/IMM](#)

- **405-806-000 : BRCM:TestLoopbackPhysical Test Aborted**

Loopback testing at the physical layer was canceled.

**Recoverable**

No

**Severity**

Warning

**Serviceable**

No

**Automatically notify support**

No

**Related links**

- [IBM Support website](#)
- [Latest level of DSA](#)

- [Latest level of BMC/IMM](#)

- **405-807-000 : BRCM:TestLEDs Test Aborted**

Verification of status LEDs was canceled.

**Recoverable**

No

**Severity**

Warning

**Serviceable**

No

**Automatically notify support**

No

**Related links**

- [IBM Support website](#)
- [Latest level of DSA](#)
- [Latest level of BMC/IMM](#)

- **405-900-000 : BRCM:TestControlRegisters Test Failed**

A failure was detected while testing internal MAC registers

**Recoverable**

No

**Severity**

Error

**Serviceable**

Yes

**Automatically notify support**

No

**User Response**

Complete the following steps:

1. Check component firmware level and upgrade if necessary. The installed firmware level can be found in the DSA Diagnostic Event Log within the Firmware/VPD section for this component.
2. Rerun the test.
3. If failure remains, refer to "Troubleshooting by symptom" in the system "Installation and Service Guide" for the next corrective action.

**Related links**

- [IBM Support website](#)
- [Latest level of DSA](#)
- [Latest level of BMC/IMM](#)

- **405-901-000 : BRCM:TestMIIRegisters Test Failed**

A failure was detected while testing internal PHY registers.

**Recoverable**

No

**Severity**

Error

**Serviceable**

Yes

**Automatically notify support**

No

**User Response**

Complete the following steps:

1. Check component firmware level and upgrade if necessary. The installed firmware level can be found in the DSA Diagnostic Event Log within the Firmware/VPD section for this component.
2. Rerun the test.
3. If failure remains, refer to "Troubleshooting by symptom" in the system "Installation and Service Guide" for the next corrective action.

**Related links**

- [IBM Support website](#)
  - [Latest level of DSA](#)
  - [Latest level of BMC/IMM](#)
- **405-902-000 : BRCM:TestEEPROM Test Failed**  
A failure was detected while testing non-volatile RAM.

**Recoverable**

No

**Severity**

Error

**Serviceable**

Yes

**Automatically notify support**

No

**User Response**

Complete the following steps:

1. Check component firmware level and upgrade if necessary. The installed firmware level can be found in the DSA Diagnostic Event Log within the Firmware/VPD section for this component.
2. Rerun the test.
3. If failure remains, refer to "Troubleshooting by symptom" in the system "Installation and Service Guide" for the next corrective action.

**Related links**

- [IBM Support website](#)
  - [Latest level of DSA](#)
  - [Latest level of BMC/IMM](#)
- **405-903-000 : BRCM:TestInternalMemory Test Failed**  
A failure was detected while testing internal memory.

**Recoverable**

No

**Severity**

Error

**Serviceable**

Yes

**Automatically notify support**

No

**User Response**

Complete the following steps:

1. Check component firmware level and upgrade if necessary. The installed firmware level can be found in the DSA Diagnostic Event Log within the Firmware/VPD section for this component.
2. Rerun the test.
3. If failure remains, refer to "Troubleshooting by symptom" in the system "Installation and Service Guide" for the next corrective action.

**Related links**

- [IBM Support website](#)
- [Latest level of DSA](#)
- [Latest level of BMC/IMM](#)

• **405-904-000 : BRCM:TestInterrupt Test Failed**

A failure was detected while testing interrupts.

**Recoverable**

No

**Severity**

Error

**Serviceable**

Yes

**Automatically notify support**

No

**User Response**

Complete the following steps:

1. Check component firmware level and upgrade if necessary. The installed firmware level can be found in the DSA Diagnostic Event Log within the Firmware/VPD section for this component.
2. Rerun the test.
3. If failure remains, refer to "Troubleshooting by symptom" in the system "Installation and Service Guide" for the next corrective action.

**Related links**

- [IBM Support website](#)
- [Latest level of DSA](#)
- [Latest level of BMC/IMM](#)

• **405-905-000 : BRCM:TestLoopbackMAC Test Failed**

BRCM:TestLoopbackMAC Test Failed.

**Recoverable**

No

**Severity**

Error

**Serviceable**

Yes

**Automatically notify support**

No

**User Response**

Complete the following steps:

1. Check component firmware level and upgrade if necessary. The installed firmware level can be found in the DSA Diagnostic Event Log within the Firmware/VPD section for this component.



2. Rerun the test.
3. If failure remains, refer to "Troubleshooting by symptom" in the system "Installation and Service Guide" for the next corrective action.

**Related links**

- [IBM Support website](#)
- [Latest level of DSA](#)
- [Latest level of BMC/IMM](#)

- **405-906-000 : BRCM:TestLoopbackPhysical Test Failed**

A failure was detected during the loopback test at the physical layer.

**Recoverable**

No

**Severity**

Error

**Serviceable**

Yes

**Automatically notify support**

No

**User Response**

Complete the following steps:

1. Check component firmware level and upgrade if necessary. The installed firmware level can be found in the DSA Diagnostic Event Log within the Firmware/VPD section for this component.
2. Rerun the test.
3. If failure remains, refer to "Troubleshooting by symptom" in the system "Installation and Service Guide" for the next corrective action.

**Related links**

- [IBM Support website](#)
- [Latest level of DSA](#)
- [Latest level of BMC/IMM](#)

- **405-907-000 : BRCM:TestLEDs Test Failed**

A failure was detected while verifying operation of the status LEDs.

**Recoverable**

No

**Severity**

Error

**Serviceable**

Yes

**Automatically notify support**

No

**User Response**

Complete the following steps:

1. Check component firmware level and upgrade if necessary. The installed firmware level can be found in the DSA Diagnostic Event Log within the Firmware/VPD section for this component.
2. Rerun the test.
3. If failure remains, refer to "Troubleshooting by symptom" in the system "Installation and Service Guide" for the next corrective action.

#### Related links

- [IBM Support website](#)
- [Latest level of DSA](#)
- [Latest level of BMC/IMM](#)

---

## DSA Brocade test results

The following messages can result when you run the Brocade test.

### Test results for the DSA Brocade test

The following messages can result when you run the DSA Brocade test.

- **218-000-000 : Brocade:MemoryTest Passed**

The test passed.

**Recoverable**

No

**Severity**

Event

**Serviceable**

No

**Automatically notify support**

No

**Related links**

- [IBM Support website](#)
- [Latest level of DSA](#)
- [Latest level of BMC/IMM](#)

- **218-001-000 : Brocade:ExternalLoopbackTest Passed**

The test passed.

**Recoverable**

No

**Severity**

Event

**Serviceable**

No

**Automatically notify support**

No

**Related links**

- [IBM Support website](#)
- [Latest level of DSA](#)
- [Latest level of BMC/IMM](#)

- **218-002-000 : Brocade:SerdesLoopbackTest Passed**

The test passed.

**Recoverable**

No

**Severity**

Event

**Serviceable**

No

**Automatically notify support**

No

**Related links**

- [IBM Support website](#)
- [Latest level of DSA](#)
- [Latest level of BMC/IMM](#)

• **218-003-000 : Brocade:PCILoopbackTest Passed**

The test passed.

**Recoverable**

No

**Severity**

Event

**Serviceable**

No

**Automatically notify support**

No

**Related links**

- [IBM Support website](#)
- [Latest level of DSA](#)
- [Latest level of BMC/IMM](#)

• **218-004-000 : Brocade:ExternalEthLoopbackTest Passed**

The test passed.

**Recoverable**

No

**Severity**

Event

**Serviceable**

No

**Automatically notify support**

No

**Related links**

- [IBM Support website](#)
- [Latest level of DSA](#)
- [Latest level of BMC/IMM](#)

• **218-005-000 : Brocade:SerdesEthLoopbackTest Passed**

The test passed.

**Recoverable**

No

**Severity**

Event

**Serviceable**

No

**Automatically notify support**

No

**Related links**

- [IBM Support website](#)
- [Latest level of DSA](#)
- [Latest level of BMC/IMM](#)

• **218-006-000 : Brocade:InternalLoopbackTest Passed**

The test passed.

**Recoverable**

No

**Severity**

Event

**Serviceable**

No

**Automatically notify support**

No

**Related links**

- [IBM Support website](#)
- [Latest level of DSA](#)
- [Latest level of BMC/IMM](#)

• **218-800-000 : Brocade:MemoryTest Aborted**

The test was canceled.

**Recoverable**

No

**Severity**

Warning

**Serviceable**

No

**Automatically notify support**

No

**Related links**

- [IBM Support website](#)
- [Latest level of DSA](#)
- [Latest level of BMC/IMM](#)

• **218-801-000 : Brocade:ExternalLoopbackTest Aborted**

The test was canceled.

**Recoverable**

No

**Severity**

Warning

**Serviceable**

No

**Automatically notify support**

No

**Related links**

- [IBM Support website](#)
- [Latest level of DSA](#)
- [Latest level of BMC/IMM](#)

• **218-802-000 : Brocade:SerdesLoopbackTest Aborted**

The test was canceled.

**Recoverable**

No

**Severity**

Warning

**Serviceable**

No

**Automatically notify support**

No

**Related links**

- [IBM Support website](#)
- [Latest level of DSA](#)
- [Latest level of BMC/IMM](#)

• **218-803-000 : Brocade:PCILoopbackTest Aborted**

The test was canceled.

**Recoverable**

No

**Severity**

Warning

**Serviceable**

No

**Automatically notify support**

No

**Related links**

- [IBM Support website](#)
- [Latest level of DSA](#)
- [Latest level of BMC/IMM](#)

• **218-804-000 : Brocade:ExternalEthLoopbackTest Aborted**

The test was canceled.

**Recoverable**

No

**Severity**

Warning

**Serviceable**

No

**Automatically notify support**

No

**Related links**

- [IBM Support website](#)
- [Latest level of DSA](#)
- [Latest level of BMC/IMM](#)

- **218-805-000 : Brocade:SerdesEthLoopbackTest Aborted**

The test was canceled.

**Recoverable**

No

**Severity**

Warning

**Serviceable**

No

**Automatically notify support**

No

**Related links**

- [IBM Support website](#)
- [Latest level of DSA](#)
- [Latest level of BMC/IMM](#)

- **218-806-000 : Brocade:InternalLoopbackTest Aborted**

The test was canceled.

**Recoverable**

No

**Severity**

Warning

**Serviceable**

No

**Automatically notify support**

No

**Related links**

- [IBM Support website](#)
- [Latest level of DSA](#)
- [Latest level of BMC/IMM](#)

- **218-900-000 : Brocade:MemoryTest Failed**

A failure was detected while testing the adapter memory.

**Recoverable**

No

**Severity**

Error

**Serviceable**

Yes

**Automatically notify support**

No

**User Response**

Complete the following steps:

1. Rerun the test.

2. Verify whether the firmware is at proper level.
3. Rerun the test.
4. If the problem remains, contact your IBM technical-support representative.

**Related links**

- [IBM Support website](#)
- [Latest level of DSA](#)
- [Latest level of BMC/IMM](#)

- **218-901-000 : Brocade:ExternalLoopbackTest Failed**

A failure was detected during the Loopback test.

**Recoverable**

No

**Severity**

Error

**Serviceable**

Yes

**Automatically notify support**

No

**User Response**

Complete the following steps:

1. Check cable connections.
2. Rerun the test.
3. Verify whether the firmware is at proper level.
4. Rerun the test.
5. If the problem remains, contact your IBM technical-support representative.

**Related links**

- [IBM Support website](#)
- [Latest level of DSA](#)
- [Latest level of BMC/IMM](#)

- **218-902-000 : Brocade:SerdesLoopbackTest Failed**

A failure was detected during the Loopback test.

**Recoverable**

No

**Severity**

Error

**Serviceable**

Yes

**Automatically notify support**

No

**User Response**

Complete the following steps:

1. Rerun the test.
2. Verify whether the firmware is at proper level.
3. Rerun the test.

4. If the problem remains, contact your IBM technical-support representative.

**Related links**

- [IBM Support website](#)
- [Latest level of DSA](#)
- [Latest level of BMC/IMM](#)

- **218-903-000 : Brocade:PCILoopbackTest Failed**

A failure was detected during the Loopback test.

**Recoverable**

No

**Severity**

Error

**Serviceable**

Yes

**Automatically notify support**

No

**User Response**

Complete the following steps:

1. Rerun the test.
2. Verify whether the firmware is at proper level.
3. Rerun the test.
4. If the problem remains, contact your IBM technical-support representative.

**Related links**

- [IBM Support website](#)
- [Latest level of DSA](#)
- [Latest level of BMC/IMM](#)

- **218-904-000 : Brocade:ExternalEthLoopbackTest Failed**

A failure was detected during the Loopback test.

**Recoverable**

No

**Severity**

Error

**Serviceable**

Yes

**Automatically notify support**

No

**User Response**

Complete the following steps:

1. Check or replace SFP/cable.
2. Rerun the test.
3. Verify whether the firmware is at proper level.
4. Rerun the test.
5. If the problem remains, contact your IBM technical-support representative.

**Related links**



- [IBM Support website](#)
- [Latest level of DSA](#)
- [Latest level of BMC/IMM](#)

- **218-905-000 : Brocade:SerdesEthLoopbackTest Failed**

A failure was detected during the Loopback test.

**Recoverable**

No

**Severity**

Error

**Serviceable**

Yes

**Automatically notify support**

No

**User Response**

Complete the following steps:

1. Rerun the test.
2. Verify whether the firmware is at proper level.
3. Rerun the test.
4. If the problem remains, contact your IBM technical-support representative.

**Related links**

- [IBM Support website](#)
- [Latest level of DSA](#)
- [Latest level of BMC/IMM](#)

- **218-906-000 : Brocade:InternalLoopbackTest Failed**

A failure was detected during the Loopback test.

**Recoverable**

No

**Severity**

Error

**Serviceable**

Yes

**Automatically notify support**

No

**User Response**

Complete the following steps:

1. Rerun the test.
2. Verify whether the firmware is at proper level.
3. Rerun the test.
4. If the problem remains, contact your IBM technical-support representative.

**Related links**

- [IBM Support website](#)
- [Latest level of DSA](#)
- [Latest level of BMC/IMM](#)

---

## DSA checkpoint panel test results

The following messages can result when you run the checkpoint panel test.

### Test results for the DSA checkpoint panel test

The following messages can result when you run the DSA checkpoint panel test.

- **180-000-000 : Check-point Panel Test Passed**

Check-point Panel Test Passed.

**Recoverable**

No

**Severity**

Event

**Serviceable**

No

**Automatically notify support**

No

**Related links**

- [IBM Support website](#)
- [Latest level of DSA](#)
- [Latest level of BMC/IMM](#)

- **180-801-000 : Check-point Panel Test Aborted**

Check-point Panel Test Aborted. BMC is unable to verify that the operator information panel cable is connected.

**Recoverable**

No

**Severity**

Warning

**Serviceable**

Yes

**Automatically notify support**

No

**User Response**

Complete the following steps:

1. Inspect and reseat operator information panel cable at both ends.
2. Verify that the Baseboard Management Controller (BMC) is working.
3. Run the test again.
4. If failure remains, refer to "Troubleshooting by symptom" in the system "Installation and Service Guide" for the next corrective action.

**Related links**

- [IBM Support website](#)
- [Latest level of DSA](#)
- [Latest level of BMC/IMM](#)

- **180-901-000 : Check-point Panel Test Failed**

Check-point Panel Test Failed. Operator reported incorrect display.

**Recoverable**

No

**Severity**

Error

**Serviceable**

Yes

**Automatically notify support**

No

**User Response**

Complete the following steps:

1. Check the operator information panel cabling for loose or broken connections at both ends or damage to the cable.
2. Replace the information panel cable if damage is present.
3. Run the test again.
4. Replace the operator information panel assembly.
5. Run the test again.
6. If failure remains, refer to "Troubleshooting by symptom" in the system "Installation and Service Guide" for the next corrective action.

**Related links**

- [IBM Support website](#)
- [Latest level of DSA](#)
- [Latest level of BMC/IMM](#)

---

## DSA CPU stress test results

The following messages can result when you run the CPU stress test.

### Test results for the DSA CPU stress test

The following messages can result when you run the DSA CPU stress test.

- **089-000-000 : CPU Stress Test Passed**

CPU Stress Test Passed.

**Recoverable**

No

**Severity**

Event

**Serviceable**

No

**Automatically notify support**

No

**Related links**

- [IBM Support website](#)
- [Latest level of DSA](#)
- [Latest level of BMC/IMM](#)

- **089-801-000 : CPU Stress Test Aborted**

CPU Stress Test Aborted. Internal Program Error.

**Recoverable**

No

**Severity**

Warning

**Serviceable**

Yes

**Automatically notify support**

No

**User Response**

Complete the following steps:

1. Turn off and restart the system.
2. Make sure that the DSA Diagnostic code is at the latest level.
3. Run the test again.
4. Check system firmware level and upgrade if necessary. The installed firmware level can be found in the DSA Diagnostic Event Log within the Firmware/VPD section for this component. The latest level firmware for this component can be found in reference to this system type at the IBM Support website.
5. Run the test again.
6. If the system has stopped responding, turn off and restart the system and then run the test again.
7. If failure remains, refer to "Troubleshooting by symptom" in the system "Installation and Service Guide" for the next corrective action.

**Related links**

- [IBM Support website](#)
- [Latest level of DSA](#)
- [Latest level of BMC/IMM](#)

- **089-802-000 : CPU Stress Test Aborted**

CPU Stress Test Aborted. System resource unavailability error.

**Recoverable**

No

**Severity**

Warning

**Serviceable**

Yes

**Automatically notify support**

No

**User Response**

Complete the following steps:

1. Turn off and restart the system.
2. Make sure that the DSA Diagnostic code is at the latest level.
3. Run the test again.
4. Check system firmware level and upgrade if necessary. The installed firmware level can be found in the DSA Diagnostic Event Log within the Firmware/VPD section for this component.

5. Run the test again.
6. If the system has stopped responding, turn off and restart the system and then run the test again.
7. If failure remains, refer to "Troubleshooting by symptom" in the system "Installation and Service Guide" for the next corrective action.

**Related links**

- [IBM Support website](#)
- [Latest level of DSA](#)
- [Latest level of BMC/IMM](#)

• **089-803-000 : CPU Stress Test Aborted**

CPU Stress Test Aborted. Memory size is insufficient to run the test. At least 1GB is required.

**Recoverable**

No

**Severity**

Warning

**Serviceable**

Yes

**Automatically notify support**

No

**Related links**

- [IBM Support website](#)
- [Latest level of DSA](#)
- [Latest level of BMC/IMM](#)

• **089-804-000 : CPU Stress Test Aborted**

CPU Stress Test Aborted. User pressed Ctrl-C.

**Recoverable**

No

**Severity**

Warning

**Serviceable**

Yes

**Automatically notify support**

No

**Related links**

- [IBM Support website](#)
- [Latest level of DSA](#)
- [Latest level of BMC/IMM](#)

• **089-901-000 : CPU Stress Test Failed**

CPU Stress Test Failed.

**Recoverable**

No

**Severity**

Error

**Serviceable**

Yes

**Automatically notify support**

No

**User Response**

Complete the following steps:

1. If the system has stopped responding, turn off and restart the system and then run the test again.
2. Make sure that the DSA Diagnostic code is at the latest level.
3. Run the test again.
4. Check system firmware level and upgrade if necessary. The installed firmware level can be found in the DSA Diagnostic Event Log within the Firmware/VPD section for this component.
5. Run the test again.
6. If the system has stopped responding, turn off and restart the system and then run the test again.
7. If failure remains, refer to "Troubleshooting by symptom" in the system "Installation and Service Guide" for the next corrective action.

**Related links**

- [IBM Support website](#)
- [Latest level of DSA](#)
- [Latest level of BMC/IMM](#)

---

## DSA Emulex adapter test results

The following messages can result when you run the Emulex adapter test.

### Test results for the DSA Emulex adapter test

The following messages can result when you run the DSA Emulex adapter test.

- **516-000-000 : ELXUCNA: NIC MAC LoopBackTest Passed**

The test passed.

**Recoverable**

No

**Severity**

Event

**Serviceable**

No

**Automatically notify support**

No

**Related links**

- [IBM Support website](#)
- [Latest level of DSA](#)
- [Latest level of BMC/IMM](#)

- **516-001-000 : ELXUCNA: NIC PHY LoopBackTest Passed**

The test passed.

**Recoverable**

No

**Severity**

Event

**Serviceable**

No

**Automatically notify support**

No

**Related links**

- [IBM Support website](#)
- [Latest level of DSA](#)
- [Latest level of BMC/IMM](#)

• **516-002-000 : ELXUCNA: ELXUCNA: NIC LED(Beacon)Test Passed**

The test passed.

**Recoverable**

No

**Severity**

Event

**Serviceable**

No

**Automatically notify support**

No

**Related links**

- [IBM Support website](#)
- [Latest level of DSA](#)
- [Latest level of BMC/IMM](#)

• **516-800-000 : ELXUCNA: NIC MAC LoopBackTest Aborted**

Loopback testing at the MAC layer was canceled.

**Recoverable**

No

**Severity**

Warning

**Serviceable**

No

**Automatically notify support**

No

**Related links**

- [IBM Support website](#)
- [Latest level of DSA](#)
- [Latest level of BMC/IMM](#)

• **516-801-000 : ELXUCNA: NIC PHY LoopBackTest Aborted**

Loopback testing at the physical layer was canceled.

**Recoverable**

No

**Severity**

Warning

**Serviceable**

No

**Automatically notify support**

No

**Related links**

- [IBM Support website](#)
- [Latest level of DSA](#)
- [Latest level of BMC/IMM](#)

- **516-802-000 : ELXUCNA: ELXUCNA: NIC LED(Beacon)Test Aborted**

Verification of status LEDs was canceled.

**Recoverable**

No

**Severity**

Warning

**Serviceable**

No

**Automatically notify support**

No

**Related links**

- [IBM Support website](#)
- [Latest level of DSA](#)
- [Latest level of BMC/IMM](#)

- **516-900-000 : ELXUCNA: NIC MAC LoopBackTest Failed**

A failure was detected during the loopback test at the MAC layer.

**Recoverable**

No

**Severity**

Error

**Serviceable**

Yes

**Automatically notify support**

No

**User Response**

Complete the following steps:

1. Check component firmware level and upgrade if necessary. The installed firmware level can be found in the DSA Diagnostic Event Log within the Firmware/VPD section for this component.
2. Rerun the test.
3. If failure remains, refer to "Troubleshooting by symptom" in the system "Installation and Service Guide" for the next corrective action.

**Related links**

- [IBM Support website](#)
- [Latest level of DSA](#)
- [Latest level of BMC/IMM](#)

- **516-901-000 : ELXUCNA: NIC PHY LoopBackTest Failed**

A failure was detected during the loopback test at the physical layer.

**Recoverable**

No



**Severity**

Error

**Serviceable**

Yes

**Automatically notify support**

No

**User Response**

Complete the following steps:

1. Check component firmware level and upgrade if necessary. The installed firmware level can be found in the DSA Diagnostic Event Log within the Firmware/VPD section for this component.
2. Rerun the test.
3. If failure remains, refer to "Troubleshooting by symptom" in the system "Installation and Service Guide" for the next corrective action.

**Related links**

- [IBM Support website](#)
  - [Latest level of DSA](#)
  - [Latest level of BMC/IMM](#)
- **516-902-000 : ELXUCNA: ELXUCNA: NIC LED(Beacon)Test Failed**

A failure was detected while verifying operation of the status LEDs.

**Recoverable**

No

**Severity**

Error

**Serviceable**

Yes

**Automatically notify support**

No

**User Response**

Complete the following steps:

1. Check component firmware level and upgrade if necessary. The installed firmware level can be found in the DSA Diagnostic Event Log within the Firmware/VPD section for this component.
2. Rerun the test.
3. If failure remains, refer to "Troubleshooting by symptom" in the system "Installation and Service Guide" for the next corrective action.

**Related links**

- [IBM Support website](#)
- [Latest level of DSA](#)
- [Latest level of BMC/IMM](#)

---

## DSA EXA port ping test results

The following messages can result when you run the EXA port ping test.

### Test results for the DSA EXA port ping test

The following messages can result when you run the DSA EXA port ping test.

- **401-000-000 : EXA Port Ping Test Passed**

EXA Port Ping Test Passed.

**Recoverable**

No

**Severity**

Event

**Serviceable**

No

**Automatically notify support**

No

**Related links**

- [IBM Support website](#)
- [Latest level of DSA](#)
- [Latest level of BMC/IMM](#)

- **401-801-000 : EXA Port Ping Test Aborted**

EXA Port Ping Test Aborted. Unable to get device base address.

**Recoverable**

No

**Severity**

Warning

**Serviceable**

Yes

**Automatically notify support**

No

**User Response**

Complete the following steps:

1. Remove power cables, wait for 45 seconds, reconnect and rerun the test.
2. Make sure that the scalability cable connections are as per specification.
3. Make sure that DSA and BIOS/uEFI are at the latest level.
4. If the problem remains, contact your technical-service representative.

**Related links**

- [IBM Support website](#)
- [Latest level of DSA](#)
- [Latest level of BMC/IMM](#)

- **401-802-000 : EXA Port Ping Test Aborted**

EXA Port Ping Test Aborted. Port connections may not be correct.

**Recoverable**

No

**Severity**

Warning

**Serviceable**

Yes

**Automatically notify support**

No

**User Response**

Complete the following steps:

1. Remove power cables, wait for 45 seconds, reconnect and rerun the test.
2. Make sure that the scalability cable connections are as per specification.
3. Make sure that DSA and BIOS/uEFI are at the latest level.
4. If the problem remains, contact your technical-service representative.

**Related links**

- [IBM Support website](#)
- [Latest level of DSA](#)
- [Latest level of BMC/IMM](#)

- **401-901-001 : EXA Port Ping Test Failed**

EXA Port Ping Test Failed.

**Recoverable**

No

**Severity**

Error

**Serviceable**

Yes

**Automatically notify support**

No

**User Response**

Complete the following steps:

1. Remove power cables, wait for 45 seconds, reconnect and rerun the test.
2. Make sure that the scalability cable connections are as per specification.
3. Check scalability cables for loose connections.
4. Replace the scalability cable(s) for specified port(s).
5. If the problem remains, contact your technical-service representative.

**Related links**

- [IBM Support website](#)
- [Latest level of DSA](#)
- [Latest level of BMC/IMM](#)

---

## DSA hard drive test results

The following messages can result when you run the hard drive test.

### Test results for the DSA hard drive test

The following messages can result when you run the DSA hard drive test.

- **217-000-000 : HDD Test Passed**

HDD Stress Test Passed.

**Recoverable**

No

**Severity**

Event

**Serviceable**

No

**Automatically notify support**

No

**Related links**

- [IBM Support website](#)
- [Latest level of DSA](#)
- [Latest level of BMC/IMM](#)

- **217-800-000 : HDD Test Aborted**

HDD Test Aborted. The test was canceled.

**Recoverable**

No

**Severity**

Warning

**Serviceable**

Yes

**Automatically notify support**

No

**User Response**

Complete the following steps:

1. Check cable connections.
2. Rerun the test.
3. Verify that Hard drive supports self test and self test logging.
4. If the problem remains, contact your technical-support representative.

**Related links**

- [IBM Support website](#)
- [Latest level of DSA](#)
- [Latest level of BMC/IMM](#)

- **217-900-000 : HDD Test Failed**

HDD Test Failed. The hard drive self-test detected a failure.

**Recoverable**

No

**Severity**

Error

**Serviceable**

Yes

**Automatically notify support**

No

**User Response**

Complete the following steps:

1. Check cable connections.
2. Rerun the test.
3. Verify the firmware is at the latest level.
4. Rerun the test.

5. If the problem remains, contact your technical-support representative.

**Related links**

- [IBM Support website](#)
- [Latest level of DSA](#)
- [Latest level of BMC/IMM](#)

---

## DSA Intel network test results

The following messages can result when you run the Intel network test.

### Test results for the DSA Intel network test

The following messages can result when you run the DSA Intel network test.

- **406-000-000 : IANet:Registers Test Passed**

The test passed.

**Recoverable**

No

**Severity**

Event

**Serviceable**

No

**Automatically notify support**

No

**Related links**

- [IBM Support website](#)
- [Latest level of DSA](#)
- [Latest level of BMC/IMM](#)

- **406-001-000 : IANet:EEPROM Test Passed**

The test passed.

**Recoverable**

No

**Severity**

Event

**Serviceable**

No

**Automatically notify support**

No

**Related links**

- [IBM Support website](#)
- [Latest level of DSA](#)
- [Latest level of BMC/IMM](#)

- **406-002-000 : IANet:FIFO Test Passed**

The test passed.

**Recoverable**

No

**Severity**

Event

**Serviceable**

No

**Automatically notify support**

No

**Related links**

- [IBM Support website](#)
- [Latest level of DSA](#)
- [Latest level of BMC/IMM](#)

- **406-003-000 : IANet:Interrupts Test Passed**

The test passed.

**Recoverable**

No

**Severity**

Event

**Serviceable**

No

**Automatically notify support**

No

**Related links**

- [IBM Support website](#)
- [Latest level of DSA](#)
- [Latest level of BMC/IMM](#)

- **406-004-000 : IANet:Loopback Test Passed**

The test passed.

**Recoverable**

No

**Severity**

Event

**Serviceable**

No

**Automatically notify support**

No

**Related links**

- [IBM Support website](#)
- [Latest level of DSA](#)
- [Latest level of BMC/IMM](#)

- **406-800-000 : IANet:Registers Test Aborted**

Registers test was canceled.

**Recoverable**

No

**Severity**

Warning

**Serviceable**

No

**Automatically notify support**

No

**Related links**

- [IBM Support website](#)
- [Latest level of DSA](#)
- [Latest level of BMC/IMM](#)

• **406-801-000 : IANet:EEPROM Test Aborted**

EEPROM test was canceled.

**Recoverable**

No

**Severity**

Warning

**Serviceable**

No

**Automatically notify support**

No

**Related links**

- [IBM Support website](#)
- [Latest level of DSA](#)
- [Latest level of BMC/IMM](#)

• **406-802-000 : IANet:FIFO Test Aborted**

FIFO test was canceled.

**Recoverable**

No

**Severity**

Warning

**Serviceable**

No

**Automatically notify support**

No

**Related links**

- [IBM Support website](#)
- [Latest level of DSA](#)
- [Latest level of BMC/IMM](#)

• **406-803-000 : IANet:Interrupts Test Aborted**

Interrupt test was canceled.

**Recoverable**

No

**Severity**

Warning

**Serviceable**

No

**Automatically notify support**

No

**Related links**

- [IBM Support website](#)
- [Latest level of DSA](#)
- [Latest level of BMC/IMM](#)

- **406-804-000 : IANet:Loopback Test Aborted**

Loopback test was canceled.

**Recoverable**

No

**Severity**

Warning

**Serviceable**

No

**Automatically notify support**

No

**Related links**

- [IBM Support website](#)
- [Latest level of DSA](#)
- [Latest level of BMC/IMM](#)

- **406-900-000 : IANet:Registers Test Failed**

A failure was detected during the Registers test.

**Recoverable**

No

**Severity**

Error

**Serviceable**

Yes

**Automatically notify support**

No

**User Response**

Complete the following steps:

1. Check component firmware level and upgrade if necessary. The installed firmware level can be found in the DSA Diagnostic Event Log within the Firmware/VPD section for this component.
2. Rerun the test.
3. If failure remains, refer to "Troubleshooting by symptom" in the system "Installation and Service Guide" for the next corrective action.

**Related links**

- [IBM Support website](#)
- [Latest level of DSA](#)
- [Latest level of BMC/IMM](#)

- **406-901-000 : IANet:EEPROM Test Failed**

A failure was detected during the EEPROM test.

**Recoverable**

No



**Severity**

Error

**Serviceable**

Yes

**Automatically notify support**

No

**User Response**

Complete the following steps:

1. Check component firmware level and upgrade if necessary. The installed firmware level can be found in the DSA Diagnostic Event Log within the Firmware/VPD section for this component.
2. Rerun the test.
3. If failure remains, refer to "Troubleshooting by symptom" in the system "Installation and Service Guide" for the next corrective action.

**Related links**

- [IBM Support website](#)
  - [Latest level of DSA](#)
  - [Latest level of BMC/IMM](#)
- **406-902-000 : IANet:FIFO Test Failed**

A failure was detected during the FIFO test.

**Recoverable**

No

**Severity**

Error

**Serviceable**

Yes

**Automatically notify support**

No

**User Response**

Complete the following steps:

1. Check component firmware level and upgrade if necessary. The installed firmware level can be found in the DSA Diagnostic Event Log within the Firmware/VPD section for this component.
2. Rerun the test.
3. If failure remains, refer to "Troubleshooting by symptom" in the system "Installation and Service Guide" for the next corrective action.

**Related links**

- [IBM Support website](#)
  - [Latest level of DSA](#)
  - [Latest level of BMC/IMM](#)
- **406-903-000 : IANet:Interrupts Test Failed**

A failure was detected during the Interrupt test.

**Recoverable**

No

**Severity**

Error

**Serviceable**

Yes

**Automatically notify support**

No

**User Response**

Complete the following steps:

1. Check component firmware level and upgrade if necessary. The installed firmware level can be found in the DSA Diagnostic Event Log within the Firmware/VPD section for this component.
2. Rerun the test.
3. Check interrupt assignments in the PCI Hardware section of the DSA Diagnostic Log. If the ethernet device is sharing interrupts, if possible modify the interrupt assignments using F1 Setup to assign a unique interrupt to the device.
4. Rerun the test.
5. If failure remains, refer to "Troubleshooting by symptom" in the system "Installation and Service Guide" for the next corrective action.

**Related links**

- [IBM Support website](#)
- [Latest level of DSA](#)
- [Latest level of BMC/IMM](#)

• **406-904-000 : IANet:Loopback Test Failed**

A failure was detected during the Loopback test.

**Recoverable**

No

**Severity**

Error

**Serviceable**

Yes

**Automatically notify support**

No

**User Response**

Complete the following steps:

1. Check the Ethernet cable for damage and ensure correct cable type and attachment.
2. Check component firmware level and upgrade if necessary. The installed firmware level can be found in the DSA Diagnostic Event Log within the Firmware/VPD section for this component.
3. Rerun the test.
4. If failure remains, refer to "Troubleshooting by symptom" in the system "Installation and Service Guide" for the next corrective action.

**Related links**

- [IBM Support website](#)
- [Latest level of DSA](#)
- [Latest level of BMC/IMM](#)

---

## DSA LSI hard drive test results

The following messages can result when you run the LSI hard drive test.

## Test results for the DSA LSI hard drive test

The following messages can result when you run the DSA LSI hard drive test.

- **407-000-000 : LSIESG:DiskDefaultDiagnostic Test Passed**

The test passed.

**Recoverable**

No

**Severity**

Event

**Serviceable**

No

**Automatically notify support**

No

**Related links**

- [IBM Support website](#)
- [Latest level of DSA](#)
- [Latest level of BMC/IMM](#)

- **407-800-000 : LSIESG:DiskDefaultDiagnostic Test Aborted**

The test was canceled.

**Recoverable**

No

**Severity**

Warning

**Serviceable**

No

**Automatically notify support**

No

**Related links**

- [IBM Support website](#)
- [Latest level of DSA](#)
- [Latest level of BMC/IMM](#)

- **407-900-000 : LSIESG:DiskDefaultDiagnostic Test Failed**

The hard drive self-test detected a failure.

**Recoverable**

No

**Severity**

Error

**Serviceable**

Yes

**Automatically notify support**

No

**User Response**

Complete the following steps:

1. Check cable connections.

2. Rerun the test.
3. Verify whether the firmware is at the latest level.
4. Rerun the test.
5. If the problem remains, contact your IBM technical-support representative.

#### Related links

- [IBM Support website](#)
- [Latest level of DSA](#)
- [Latest level of BMC/IMM](#)

---

## DSA Mellanox adapter test results

The following messages can result when you run the Mellanox adapter test.

### Test results for the DSA Mellanox adapter test

The following messages can result when you run the DSA Mellanox adapter test.

- **408-000-000 : MLNX:MLNX\_DiagnosticTestEthernetPort Test Passed**

Port Test Passed.

#### Recoverable

No

#### Severity

Event

#### Serviceable

No

#### Automatically notify support

No

#### Related links

- [IBM Support website](#)
- [Latest level of DSA](#)
- [Latest level of BMC/IMM](#)

- **408-001-000 : MLNX:MLNX\_DiagnosticTestIBPort Test Passed**

Port Test Passed.

#### Recoverable

No

#### Severity

Event

#### Serviceable

No

#### Automatically notify support

No

#### Related links

- [IBM Support website](#)
- [Latest level of DSA](#)
- [Latest level of BMC/IMM](#)

- **408-800-000 : MLNX:MLNX\_DiagnosticTestEthernetPort Test Aborted**

Port Test was canceled.

**Recoverable**

No

**Severity**

Warning

**Serviceable**

No

**Automatically notify support**

No

**Related links**

- [IBM Support website](#)
- [Latest level of DSA](#)
- [Latest level of BMC/IMM](#)

• **408-801-000 : MLNX:MLNX\_DiagnosticTestIBPort Test Aborted**

Port Test was canceled.

**Recoverable**

No

**Severity**

Warning

**Serviceable**

No

**Automatically notify support**

No

**Related links**

- [IBM Support website](#)
- [Latest level of DSA](#)
- [Latest level of BMC/IMM](#)

• **408-900-000 : MLNX:MLNX\_DiagnosticTestEthernetPort Test Failed**

Port Test Failed.

**Recoverable**

No

**Severity**

Error

**Serviceable**

Yes

**Automatically notify support**

No

**User Response**

Complete the following steps:

1. Make sure that the physical link of the port under test in the active state.
2. If these condition was met but the test keeps failing the port's adapter might be faulty.
3. Try replacing the adapter and repeating the test.

**Related links**

- [IBM Support website](#)

- [Latest level of DSA](#)
- [Latest level of BMC/IMM](#)
- **408-901-000 : MLNX:MLNX\_DiagnosticTestIBPort Test Failed**

Port Test Failed.

**Recoverable**

No

**Severity**

Error

**Serviceable**

Yes

**Automatically notify support**

No

**User Response**

Complete the following steps:

1. Make sure that the physical link of the port under test in the active state and a subnet manager running on the fabric to which the port is attached.
2. If these condition was met but the test keeps failing the port's adapter might be faulty.
3. Try replacing the adapter and repeating the test.

**Related links**

- [IBM Support website](#)
- [Latest level of DSA](#)
- [Latest level of BMC/IMM](#)

---

## DSA memory isolation test results

The following messages can result when you run the memory isolation test.

### Test results for the DSA memory isolation test

The following messages can result when you run the DSA memory isolation test.

- **201-000-000 : Standalone Memory Test Passed**

Quick/Full Memory Test All CPUs Passed.

**Recoverable**

No

**Severity**

Event

**Serviceable**

No

**Automatically notify support**

No

**Related links**

- [IBM Support website](#)
- [Latest level of DSA](#)
- [Latest level of BMC/IMM](#)

- **201-000-001 : Standalone Memory Test Passed**

Quick/Full Memory Test CPU 1 Passed.

**Recoverable**

No

**Severity**

Event

**Serviceable**

No

**Automatically notify support**

No

**Related links**

- [IBM Support website](#)
- [Latest level of DSA](#)
- [Latest level of BMC/IMM](#)

• **201-000-002 : Standalone Memory Test Passed**

Quick/Full Memory Test CPU 2 Passed.

**Recoverable**

No

**Severity**

Event

**Serviceable**

No

**Automatically notify support**

No

**Related links**

- [IBM Support website](#)
- [Latest level of DSA](#)
- [Latest level of BMC/IMM](#)

• **201-000-003 : Standalone Memory Test Passed**

Quick/Full Memory Test CPU 3 Passed.

**Recoverable**

No

**Severity**

Event

**Serviceable**

No

**Automatically notify support**

No

**Related links**

- [IBM Support website](#)
- [Latest level of DSA](#)
- [Latest level of BMC/IMM](#)

• **201-000-004 : Standalone Memory Test Passed**

Quick/Full Memory Test CPU 4 Passed.

**Recoverable**

No

**Severity**

Event

**Serviceable**

No

**Automatically notify support**

No

**Related links**

- [IBM Support website](#)
- [Latest level of DSA](#)
- [Latest level of BMC/IMM](#)

• **201-811-000 : Standalone Memory Test Aborted**

Unable to Locate SMBIOS key "\_SM\_".

**Recoverable**

No

**Severity**

Warning

**Serviceable**

No

**Automatically notify support**

No

**User Response**

Complete the following steps:

1. Perform the actions mentioned one at a time and try the test after each action.
2. If the problem remains, contact your technical-service representative.
3. Turn off the system and disconnect it from power. Wait for 45 seconds. Reseat DIMM(s). Reconnect it to power.
4. Make sure that DSA and BIOS/uEFI are at the latest level.

**Related links**

- [IBM Support website](#)
- [Latest level of DSA](#)
- [Latest level of BMC/IMM](#)

• **201-811-001 : Standalone Memory Test Aborted**

Unable to Locate SMBIOS key "\_SM\_".

**Recoverable**

No

**Severity**

Warning

**Serviceable**

No

**Automatically notify support**

No

**User Response**

Complete the following steps:



1. Perform the actions mentioned one at a time and try the test after each action.
2. If the problem remains, contact your technical-service representative.
3. Turn off the system and disconnect it from power. Wait for 45 seconds. Reseat DIMM(s). Reconnect it to power.
4. Make sure that DSA and BIOS/uEFI are at the latest level.

**Related links**

- [IBM Support website](#)
- [Latest level of DSA](#)
- [Latest level of BMC/IMM](#)

- **201-811-002 : Standalone Memory Test Aborted**

Unable to Locate SMBIOS key "\_SM\_".

**Recoverable**

No

**Severity**

Warning

**Serviceable**

No

**Automatically notify support**

No

**User Response**

Complete the following steps:

1. Perform the actions mentioned one at a time and try the test after each action.
2. If the problem remains, contact your technical-service representative.
3. Turn off the system and disconnect it from power. Wait for 45 seconds. Reseat DIMM(s). Reconnect it to power.
4. Make sure that DSA and BIOS/uEFI are at the latest level.

**Related links**

- [IBM Support website](#)
- [Latest level of DSA](#)
- [Latest level of BMC/IMM](#)

- **201-811-003 : Standalone Memory Test Aborted**

Unable to Locate SMBIOS key "\_SM\_".

**Recoverable**

No

**Severity**

Warning

**Serviceable**

No

**Automatically notify support**

No

**User Response**

Complete the following steps:

1. Perform the actions mentioned one at a time and try the test after each action.
2. If the problem remains, contact your technical-service representative.

3. Turn off the system and disconnect it from power. Wait for 45 seconds. Reseat DIMM(s). Reconnect it to power.
4. Make sure that DSA and BIOS/uEFI are at the latest level.

**Related links**

- [IBM Support website](#)
- [Latest level of DSA](#)
- [Latest level of BMC/IMM](#)

- **201-812-000 : Standalone Memory Test Aborted**

Memory test is not supported for this system.

**Recoverable**

No

**Severity**

Warning

**Serviceable**

No

**Automatically notify support**

No

**User Response**

Complete the following steps:

1. Perform the actions mentioned one at a time and try the test after each action.
2. If the problem remains, contact your technical-service representative.
3. Turn off the system and disconnect it from power. Wait for 45 seconds. Reseat DIMM(s). Reconnect it to power.
4. Make sure that DSA and BIOS/uEFI are at the latest level.

**Related links**

- [IBM Support website](#)
- [Latest level of DSA](#)
- [Latest level of BMC/IMM](#)

- **201-812-001 : Standalone Memory Test Aborted**

Memory test is not supported for this system.

**Recoverable**

No

**Severity**

Warning

**Serviceable**

No

**Automatically notify support**

No

**User Response**

Complete the following steps:

1. Perform the actions mentioned one at a time and try the test after each action.
2. If the problem remains, contact your technical-service representative.
3. Turn off the system and disconnect it from power. Wait for 45 seconds. Reseat DIMM(s). Reconnect it to power.

4. Make sure that DSA and BIOS/uEFI are at the latest level.

**Related links**

- [IBM Support website](#)
- [Latest level of DSA](#)
- [Latest level of BMC/IMM](#)

- **201-812-002 : Standalone Memory Test Aborted**

Memory test is not supported for this system.

**Recoverable**

No

**Severity**

Warning

**Serviceable**

No

**Automatically notify support**

No

**User Response**

Complete the following steps:

1. Perform the actions mentioned one at a time and try the test after each action.
2. If the problem remains, contact your technical-service representative.
3. Turn off the system and disconnect it from power. Wait for 45 seconds. Reseat DIMM(s). Reconnect it to power.
4. Make sure that DSA and BIOS/uEFI are at the latest level.

**Related links**

- [IBM Support website](#)
- [Latest level of DSA](#)
- [Latest level of BMC/IMM](#)

- **201-812-003 : Standalone Memory Test Aborted**

Memory test is not supported for this system.

**Recoverable**

No

**Severity**

Warning

**Serviceable**

No

**Automatically notify support**

No

**User Response**

Complete the following steps:

1. Perform the actions mentioned one at a time and try the test after each action.
2. If the problem remains, contact your technical-service representative.
3. Turn off the system and disconnect it from power. Wait for 45 seconds. Reseat DIMM(s). Reconnect it to power.
4. Make sure that DSA and BIOS/uEFI are at the latest level.

**Related links**

- [IBM Support website](#)
- [Latest level of DSA](#)
- [Latest level of BMC/IMM](#)

- **201-813-000 : Standalone Memory Test Aborted**

Chipset Error: Can not turn OFF ECC error reporting in CPU.

**Recoverable**

No

**Severity**

Warning

**Serviceable**

No

**Automatically notify support**

No

**User Response**

Complete the following steps:

1. Perform the actions mentioned one at a time and try the test after each action.
2. If the problem remains, contact your technical-service representative.
3. Turn off the system and disconnect it from power. Wait for 45 seconds. Reseat DIMM(s). Reconnect it to power.
4. Make sure that DSA and BIOS/uEFI are at the latest level.

**Related links**

- [IBM Support website](#)
- [Latest level of DSA](#)
- [Latest level of BMC/IMM](#)

- **201-813-001 : Standalone Memory Test Aborted**

Chipset Error: Can not turn OFF ECC error reporting in CPU.

**Recoverable**

No

**Severity**

Warning

**Serviceable**

No

**Automatically notify support**

No

**User Response**

Complete the following steps:

1. Perform the actions mentioned one at a time and try the test after each action.
2. If the problem remains, contact your technical-service representative.
3. Turn off the system and disconnect it from power. Wait for 45 seconds. Reseat DIMM(s). Reconnect it to power.
4. Make sure that DSA and BIOS/uEFI are at the latest level.

**Related links**

- [IBM Support website](#)
- [Latest level of DSA](#)

- [Latest level of BMC/IMM](#)
- **201-813-002 : Standalone Memory Test Aborted**  
Chipset Error: Can not turn OFF ECC error reporting in CPU.

**Recoverable**

No

**Severity**

Warning

**Serviceable**

No

**Automatically notify support**

No

**User Response**

Complete the following steps:

1. Perform the actions mentioned one at a time and try the test after each action.
2. If the problem remains, contact your technical-service representative.
3. Turn off the system and disconnect it from power. Wait for 45 seconds. Reseat DIMM(s). Reconnect it to power.
4. Make sure that DSA and BIOS/uEFI are at the latest level.

**Related links**

- [IBM Support website](#)
- [Latest level of DSA](#)
- [Latest level of BMC/IMM](#)
- **201-813-003 : Standalone Memory Test Aborted**  
Chipset Error: Can not turn OFF ECC error reporting in CPU.

**Recoverable**

No

**Severity**

Warning

**Serviceable**

No

**Automatically notify support**

No

**User Response**

Complete the following steps:

1. Perform the actions mentioned one at a time and try the test after each action.
2. If the problem remains, contact your technical-service representative.
3. Turn off the system and disconnect it from power. Wait for 45 seconds. Reseat DIMM(s). Reconnect it to power.
4. Make sure that DSA and BIOS/uEFI are at the latest level.

**Related links**

- [IBM Support website](#)
- [Latest level of DSA](#)
- [Latest level of BMC/IMM](#)
- **201-814-000 : Standalone Memory Test Aborted**

Chipset Error: Can not disable Scubbing feature for CPU.

**Recoverable**

No

**Severity**

Warning

**Serviceable**

No

**Automatically notify support**

No

**User Response**

Complete the following steps:

1. Perform the actions mentioned one at a time and try the test after each action.
2. If the problem remains, contact your technical-service representative.
3. Turn off the system and disconnect it from power. Wait for 45 seconds. Reseat DIMM(s). Reconnect it to power.
4. Make sure that DSA and BIOS/uEFI are at the latest level.

**Related links**

- [IBM Support website](#)
- [Latest level of DSA](#)
- [Latest level of BMC/IMM](#)

• **201-814-001 : Standalone Memory Test Aborted**

Chipset Error: Can not disable Scubbing feature for CPU.

**Recoverable**

No

**Severity**

Warning

**Serviceable**

No

**Automatically notify support**

No

**User Response**

Complete the following steps:

1. Perform the actions mentioned one at a time and try the test after each action.
2. If the problem remains, contact your technical-service representative.
3. Turn off the system and disconnect it from power. Wait for 45 seconds. Reseat DIMM(s). Reconnect it to power.
4. Make sure that DSA and BIOS/uEFI are at the latest level.

**Related links**

- [IBM Support website](#)
- [Latest level of DSA](#)
- [Latest level of BMC/IMM](#)

• **201-814-002 : Standalone Memory Test Aborted**

Chipset Error: Can not disable Scubbing feature for CPU.

**Recoverable**

No

**Severity**

Warning

**Serviceable**

No

**Automatically notify support**

No

**User Response**

Complete the following steps:

1. Perform the actions mentioned one at a time and try the test after each action.
2. If the problem remains, contact your technical-service representative.
3. Turn off the system and disconnect it from power. Wait for 45 seconds. Reseat DIMM(s). Reconnect it to power.
4. Make sure that DSA and BIOS/uEFI are at the latest level.

**Related links**

- [IBM Support website](#)
- [Latest level of DSA](#)
- [Latest level of BMC/IMM](#)

- **201-814-003 : Standalone Memory Test Aborted**

Chipset Error: Can not disable Scubbing feature for CPU.

**Recoverable**

No

**Severity**

Warning

**Serviceable**

No

**Automatically notify support**

No

**User Response**

Complete the following steps:

1. Perform the actions mentioned one at a time and try the test after each action.
2. If the problem remains, contact your technical-service representative.
3. Turn off the system and disconnect it from power. Wait for 45 seconds. Reseat DIMM(s). Reconnect it to power.
4. Make sure that DSA and BIOS/uEFI are at the latest level.

**Related links**

- [IBM Support website](#)
- [Latest level of DSA](#)
- [Latest level of BMC/IMM](#)

- **201-815-000 : Standalone Memory Test Aborted**

Program Error with Quick Memory Menu Option Selection.

**Recoverable**

No

**Severity**

Warning

**Serviceable**

No

**Automatically notify support**

No

**User Response**

Complete the following steps:

1. Perform the actions mentioned one at a time and try the test after each action.
2. If the problem remains, contact your technical-service representative.
3. Turn off the system and disconnect it from power. Wait for 45 seconds. Reseat DIMM(s). Reconnect it to power.
4. Make sure that DSA and BIOS/uEFI are at the latest level.

**Related links**

- [IBM Support website](#)
- [Latest level of DSA](#)
- [Latest level of BMC/IMM](#)

- **201-815-001 : Standalone Memory Test Aborted**

Program Error with Quick Memory Menu Option Selection.

**Recoverable**

No

**Severity**

Warning

**Serviceable**

No

**Automatically notify support**

No

**User Response**

Complete the following steps:

1. Perform the actions mentioned one at a time and try the test after each action.
2. If the problem remains, contact your technical-service representative.
3. Turn off the system and disconnect it from power. Wait for 45 seconds. Reseat DIMM(s). Reconnect it to power.
4. Make sure that DSA and BIOS/uEFI are at the latest level.

**Related links**

- [IBM Support website](#)
- [Latest level of DSA](#)
- [Latest level of BMC/IMM](#)

- **201-815-002 : Standalone Memory Test Aborted**

Program Error with Quick Memory Menu Option Selection.

**Recoverable**

No

**Severity**

Warning



**Serviceable**

No

**Automatically notify support**

No

**User Response**

Complete the following steps:

1. Perform the actions mentioned one at a time and try the test after each action.
2. If the problem remains, contact your technical-service representative.
3. Turn off the system and disconnect it from power. Wait for 45 seconds. Reseat DIMM(s). Reconnect it to power.
4. Make sure that DSA and BIOS/uEFI are at the latest level.

**Related links**

- [IBM Support website](#)
- [Latest level of DSA](#)
- [Latest level of BMC/IMM](#)

- **201-815-003 : Standalone Memory Test Aborted**

Program Error with Quick Memory Menu Option Selection.

**Recoverable**

No

**Severity**

Warning

**Serviceable**

No

**Automatically notify support**

No

**User Response**

Complete the following steps:

1. Perform the actions mentioned one at a time and try the test after each action.
2. If the problem remains, contact your technical-service representative.
3. Turn off the system and disconnect it from power. Wait for 45 seconds. Reseat DIMM(s). Reconnect it to power.
4. Make sure that DSA and BIOS/uEFI are at the latest level.

**Related links**

- [IBM Support website](#)
- [Latest level of DSA](#)
- [Latest level of BMC/IMM](#)

- **201-816-000 : Standalone Memory Test Aborted**

Program Error with Full Memory Menu Option Selection.

**Recoverable**

No

**Severity**

Warning

**Serviceable**

No

**Automatically notify support**

No

**User Response**

Complete the following steps:

1. Perform the actions mentioned one at a time and try the test after each action.
2. If the problem remains, contact your technical-service representative.
3. Turn off the system and disconnect it from power. Wait for 45 seconds. Reseat DIMM(s). Reconnect it to power.
4. Make sure that DSA and BIOS/uEFI are at the latest level.

**Related links**

- [IBM Support website](#)
- [Latest level of DSA](#)
- [Latest level of BMC/IMM](#)

- **201-816-001 : Standalone Memory Test Aborted**

Program Error with Full Memory Menu Option Selection.

**Recoverable**

No

**Severity**

Warning

**Serviceable**

No

**Automatically notify support**

No

**User Response**

Complete the following steps:

1. Perform the actions mentioned one at a time and try the test after each action.
2. If the problem remains, contact your technical-service representative.
3. Turn off the system and disconnect it from power. Wait for 45 seconds. Reseat DIMM(s). Reconnect it to power.
4. Make sure that DSA and BIOS/uEFI are at the latest level.

**Related links**

- [IBM Support website](#)
- [Latest level of DSA](#)
- [Latest level of BMC/IMM](#)

- **201-816-002 : Standalone Memory Test Aborted**

Program Error with Full Memory Menu Option Selection.

**Recoverable**

No

**Severity**

Warning

**Serviceable**

No

**Automatically notify support**

No

**User Response**

Complete the following steps:

1. Perform the actions mentioned one at a time and try the test after each action.
2. If the problem remains, contact your technical-service representative.
3. Turn off the system and disconnect it from power. Wait for 45 seconds. Reseat DIMM(s). Reconnect it to power.
4. Make sure that DSA and BIOS/uEFI are at the latest level.

**Related links**

- [IBM Support website](#)
- [Latest level of DSA](#)
- [Latest level of BMC/IMM](#)

- **201-816-003 : Standalone Memory Test Aborted**

Program Error with Full Memory Menu Option Selection.

**Recoverable**

No

**Severity**

Warning

**Serviceable**

No

**Automatically notify support**

No

**User Response**

Complete the following steps:

1. Perform the actions mentioned one at a time and try the test after each action.
2. If the problem remains, contact your technical-service representative.
3. Turn off the system and disconnect it from power. Wait for 45 seconds. Reseat DIMM(s). Reconnect it to power.
4. Make sure that DSA and BIOS/uEFI are at the latest level.

**Related links**

- [IBM Support website](#)
- [Latest level of DSA](#)
- [Latest level of BMC/IMM](#)

- **201-818-000 : Standalone Memory Test Aborted**

Unable to Locate SMBIOS key "\_SM\_".

**Recoverable**

No

**Severity**

Warning

**Serviceable**

No

**Automatically notify support**

No

**User Response**

Complete the following steps:

1. Perform the actions mentioned one at a time and try the test after each action.
2. If the problem remains, contact your technical-service representative.
3. Turn off the system and disconnect it from power. Wait for 45 seconds. Reseat DIMM(s). Reconnect it to power.
4. Make sure that DSA and BIOS/uEFI are at the latest level.

**Related links**

- [IBM Support website](#)
- [Latest level of DSA](#)
- [Latest level of BMC/IMM](#)

**• 201-818-001 : Standalone Memory Test Aborted**

Unable to Locate SMBIOS key "\_SM\_".

**Recoverable**

No

**Severity**

Warning

**Serviceable**

No

**Automatically notify support**

No

**User Response**

Complete the following steps:

1. Perform the actions mentioned one at a time and try the test after each action.
2. If the problem remains, contact your technical-service representative.
3. Turn off the system and disconnect it from power. Wait for 45 seconds. Reseat DIMM(s). Reconnect it to power.
4. Make sure that DSA and BIOS/uEFI are at the latest level.

**Related links**

- [IBM Support website](#)
- [Latest level of DSA](#)
- [Latest level of BMC/IMM](#)

**• 201-818-002 : Standalone Memory Test Aborted**

Unable to Locate SMBIOS key "\_SM\_".

**Recoverable**

No

**Severity**

Warning

**Serviceable**

No

**Automatically notify support**

No

**User Response**

Complete the following steps:

1. Perform the actions mentioned one at a time and try the test after each action.
2. If the problem remains, contact your technical-service representative.

3. Turn off the system and disconnect it from power. Wait for 45 seconds. Reseat DIMM(s). Reconnect it to power.
4. Make sure that DSA and BIOS/uEFI are at the latest level.

**Related links**

- [IBM Support website](#)
- [Latest level of DSA](#)
- [Latest level of BMC/IMM](#)

- **201-818-003 : Standalone Memory Test Aborted**

Unable to Locate SMBIOS key "\_SM\_".

**Recoverable**

No

**Severity**

Warning

**Serviceable**

No

**Automatically notify support**

No

**User Response**

Complete the following steps:

1. Perform the actions mentioned one at a time and try the test after each action.
2. If the problem remains, contact your technical-service representative.
3. Turn off the system and disconnect it from power. Wait for 45 seconds. Reseat DIMM(s). Reconnect it to power.
4. Make sure that DSA and BIOS/uEFI are at the latest level.

**Related links**

- [IBM Support website](#)
- [Latest level of DSA](#)
- [Latest level of BMC/IMM](#)

- **201-819-000 : Standalone Memory Test Aborted**

The start-end address ranges in the restricted area of the memory.

**Recoverable**

No

**Severity**

Warning

**Serviceable**

No

**Automatically notify support**

No

**User Response**

Complete the following steps:

1. Perform the actions mentioned one at a time and try the test after each action.
2. If the problem remains, contact your technical-service representative.
3. Turn off the system and disconnect it from power. Wait for 45 seconds. Reseat DIMM(s). Reconnect it to power.

4. Make sure that DSA and BIOS/uEFI are at the latest level.

**Related links**

- [IBM Support website](#)
- [Latest level of DSA](#)
- [Latest level of BMC/IMM](#)

- **201-819-001 : Standalone Memory Test Aborted**

The start-end address ranges in the restricted area of the memory.

**Recoverable**

No

**Severity**

Warning

**Serviceable**

No

**Automatically notify support**

No

**User Response**

Complete the following steps:

1. Perform the actions mentioned one at a time and try the test after each action.
2. If the problem remains, contact your technical-service representative.
3. Turn off the system and disconnect it from power. Wait for 45 seconds. Reseat DIMM(s). Reconnect it to power.
4. Make sure that DSA and BIOS/uEFI are at the latest level.

**Related links**

- [IBM Support website](#)
- [Latest level of DSA](#)
- [Latest level of BMC/IMM](#)

- **201-819-002 : Standalone Memory Test Aborted**

The start-end address ranges in the restricted area of the memory.

**Recoverable**

No

**Severity**

Warning

**Serviceable**

No

**Automatically notify support**

No

**User Response**

Complete the following steps:

1. Perform the actions mentioned one at a time and try the test after each action.
2. If the problem remains, contact your technical-service representative.
3. Turn off the system and disconnect it from power. Wait for 45 seconds. Reseat DIMM(s). Reconnect it to power.
4. Make sure that DSA and BIOS/uEFI are at the latest level.

**Related links**

- [IBM Support website](#)
- [Latest level of DSA](#)
- [Latest level of BMC/IMM](#)

- **201-819-003 : Standalone Memory Test Aborted**

The start-end address ranges in the restricted area of the memory.

**Recoverable**

No

**Severity**

Warning

**Serviceable**

No

**Automatically notify support**

No

**User Response**

Complete the following steps:

1. Perform the actions mentioned one at a time and try the test after each action.
2. If the problem remains, contact your technical-service representative.
3. Turn off the system and disconnect it from power. Wait for 45 seconds. Reseat DIMM(s). Reconnect it to power.
4. Make sure that DSA and BIOS/uEFI are at the latest level.

**Related links**

- [IBM Support website](#)
- [Latest level of DSA](#)
- [Latest level of BMC/IMM](#)

- **201-820-000 : Standalone Memory Test Aborted**

Memory Upper limit is less than 16 Mbytes.

**Recoverable**

No

**Severity**

Warning

**Serviceable**

No

**Automatically notify support**

No

**User Response**

Complete the following steps:

1. Perform the actions mentioned one at a time and try the test after each action.
2. If the problem remains, contact your technical-service representative.
3. Turn off the system and disconnect it from power. Wait for 45 seconds. Reseat DIMM(s). Reconnect it to power.
4. Make sure that DSA and BIOS/uEFI are at the latest level.

**Related links**

- [IBM Support website](#)
- [Latest level of DSA](#)

- [Latest level of BMC/IMM](#)
- **201-820-001 : Standalone Memory Test Aborted**

Memory Upper limit is less than 16 Mbytes.

**Recoverable**

No

**Severity**

Warning

**Serviceable**

No

**Automatically notify support**

No

**User Response**

Complete the following steps:

1. Perform the actions mentioned one at a time and try the test after each action.
2. If the problem remains, contact your technical-service representative.
3. Turn off the system and disconnect it from power. Wait for 45 seconds. Reseat DIMM(s). Reconnect it to power.
4. Make sure that DSA and BIOS/uEFI are at the latest level.

**Related links**

- [IBM Support website](#)
- [Latest level of DSA](#)
- [Latest level of BMC/IMM](#)
- **201-820-002 : Standalone Memory Test Aborted**

Memory Upper limit is less than 16 Mbytes.

**Recoverable**

No

**Severity**

Warning

**Serviceable**

No

**Automatically notify support**

No

**User Response**

Complete the following steps:

1. Perform the actions mentioned one at a time and try the test after each action.
2. If the problem remains, contact your technical-service representative.
3. Turn off the system and disconnect it from power. Wait for 45 seconds. Reseat DIMM(s). Reconnect it to power.
4. Make sure that DSA and BIOS/uEFI are at the latest level.

**Related links**

- [IBM Support website](#)
- [Latest level of DSA](#)
- [Latest level of BMC/IMM](#)
- **201-820-003 : Standalone Memory Test Aborted**



Memory Upper limit is less than 16 Mbytes.

**Recoverable**

No

**Severity**

Warning

**Serviceable**

No

**Automatically notify support**

No

**User Response**

Complete the following steps:

1. Perform the actions mentioned one at a time and try the test after each action.
2. If the problem remains, contact your technical-service representative.
3. Turn off the system and disconnect it from power. Wait for 45 seconds. Reseat DIMM(s). Reconnect it to power.
4. Make sure that DSA and BIOS/uEFI are at the latest level.

**Related links**

- [IBM Support website](#)
- [Latest level of DSA](#)
- [Latest level of BMC/IMM](#)

• **201-821-000 : Standalone Memory Test Aborted**

Variable range MTRR registers are larger than fixed range MTRR registers.

**Recoverable**

No

**Severity**

Warning

**Serviceable**

No

**Automatically notify support**

No

**User Response**

Complete the following steps:

1. Perform the actions mentioned one at a time and try the test after each action.
2. If the problem remains, contact your technical-service representative.
3. Turn off the system and disconnect it from power. Wait for 45 seconds. Reseat DIMM(s). Reconnect it to power.
4. Make sure that DSA and BIOS/uEFI are at the latest level.

**Related links**

- [IBM Support website](#)
- [Latest level of DSA](#)
- [Latest level of BMC/IMM](#)

• **201-821-001 : Standalone Memory Test Aborted**

Variable range MTRR registers are larger than fixed range MTRR registers.

**Recoverable**

No

**Severity**

Warning

**Serviceable**

No

**Automatically notify support**

No

**User Response**

Complete the following steps:

1. Perform the actions mentioned one at a time and try the test after each action.
2. If the problem remains, contact your technical-service representative.
3. Turn off the system and disconnect it from power. Wait for 45 seconds. Reseat DIMM(s). Reconnect it to power.
4. Make sure that DSA and BIOS/uEFI are at the latest level.

**Related links**

- [IBM Support website](#)
- [Latest level of DSA](#)
- [Latest level of BMC/IMM](#)

- **201-821-002 : Standalone Memory Test Aborted**

Variable range MTRR registers are larger than fixed range MTRR registers.

**Recoverable**

No

**Severity**

Warning

**Serviceable**

No

**Automatically notify support**

No

**User Response**

Complete the following steps:

1. Perform the actions mentioned one at a time and try the test after each action.
2. If the problem remains, contact your technical-service representative.
3. Turn off the system and disconnect it from power. Wait for 45 seconds. Reseat DIMM(s). Reconnect it to power.
4. Make sure that DSA and BIOS/uEFI are at the latest level.

**Related links**

- [IBM Support website](#)
- [Latest level of DSA](#)
- [Latest level of BMC/IMM](#)

- **201-821-003 : Standalone Memory Test Aborted**

Variable range MTRR registers are larger than fixed range MTRR registers.

**Recoverable**

No

**Severity**

Warning

**Serviceable**

No

**Automatically notify support**

No

**User Response**

Complete the following steps:

1. Perform the actions mentioned one at a time and try the test after each action.
2. If the problem remains, contact your technical-service representative.
3. Turn off the system and disconnect it from power. Wait for 45 seconds. Reseat DIMM(s). Reconnect it to power.
4. Make sure that DSA and BIOS/uEFI are at the latest level.

**Related links**

- [IBM Support website](#)
- [Latest level of DSA](#)
- [Latest level of BMC/IMM](#)

- **201-822-000 : Standalone Memory Test Aborted**

Invalid MTRR service request.

**Recoverable**

No

**Severity**

Warning

**Serviceable**

No

**Automatically notify support**

No

**User Response**

Complete the following steps:

1. Perform the actions mentioned one at a time and try the test after each action.
2. If the problem remains, contact your technical-service representative.
3. Turn off the system and disconnect it from power. Wait for 45 seconds. Reseat DIMM(s). Reconnect it to power.
4. Make sure that DSA and BIOS/uEFI are at the latest level.

**Related links**

- [IBM Support website](#)
- [Latest level of DSA](#)
- [Latest level of BMC/IMM](#)

- **201-822-001 : Standalone Memory Test Aborted**

Invalid MTRR service request.

**Recoverable**

No

**Severity**

Warning

**Serviceable**

No

**Automatically notify support**

No

**User Response**

Complete the following steps:

1. Perform the actions mentioned one at a time and try the test after each action.
2. If the problem remains, contact your technical-service representative.
3. Turn off the system and disconnect it from power. Wait for 45 seconds. Reseat DIMM(s). Reconnect it to power.
4. Make sure that DSA and BIOS/uEFI are at the latest level.

**Related links**

- [IBM Support website](#)
- [Latest level of DSA](#)
- [Latest level of BMC/IMM](#)

- **201-822-002 : Standalone Memory Test Aborted**

Invalid MTRR service request.

**Recoverable**

No

**Severity**

Warning

**Serviceable**

No

**Automatically notify support**

No

**User Response**

Complete the following steps:

1. Perform the actions mentioned one at a time and try the test after each action.
2. If the problem remains, contact your technical-service representative.
3. Turn off the system and disconnect it from power. Wait for 45 seconds. Reseat DIMM(s). Reconnect it to power.
4. Make sure that DSA and BIOS/uEFI are at the latest level.

**Related links**

- [IBM Support website](#)
- [Latest level of DSA](#)
- [Latest level of BMC/IMM](#)

- **201-822-003 : Standalone Memory Test Aborted**

Invalid MTRR service request.

**Recoverable**

No

**Severity**

Warning

**Serviceable**

No

**Automatically notify support**

No

**User Response**

Complete the following steps:

1. Perform the actions mentioned one at a time and try the test after each action.
2. If the problem remains, contact your technical-service representative.
3. Turn off the system and disconnect it from power. Wait for 45 seconds. Reseat DIMM(s). Reconnect it to power.
4. Make sure that DSA and BIOS/uEFI are at the latest level.

**Related links**

- [IBM Support website](#)
- [Latest level of DSA](#)
- [Latest level of BMC/IMM](#)

- **201-824-000 : Standalone Memory Test Aborted**

Node Interleave feature must be OFF. Go to Setup and disable Node Interleave option and then re-run the test.

**Recoverable**

No

**Severity**

Warning

**Serviceable**

No

**Automatically notify support**

No

**User Response**

Complete the following steps:

1. Perform the actions mentioned one at a time and try the test after each action.
2. If the problem remains, contact your technical-service representative.
3. Turn off the system and disconnect it from power. Wait for 45 seconds. Reseat DIMM(s). Reconnect it to power.
4. Make sure that DSA and BIOS/uEFI are at the latest level.

**Related links**

- [IBM Support website](#)
- [Latest level of DSA](#)
- [Latest level of BMC/IMM](#)

- **201-824-001 : Standalone Memory Test Aborted**

Node Interleave feature must be OFF. Go to Setup and disable Node Interleave option and then re-run the test.

**Recoverable**

No

**Severity**

Warning

**Serviceable**

No

**Automatically notify support**

No

**User Response**

Complete the following steps:

1. Perform the actions mentioned one at a time and try the test after each action.
2. If the problem remains, contact your technical-service representative.
3. Turn off the system and disconnect it from power. Wait for 45 seconds. Reseat DIMM(s). Reconnect it to power.
4. Make sure that DSA and BIOS/uEFI are at the latest level.

**Related links**

- [IBM Support website](#)
- [Latest level of DSA](#)
- [Latest level of BMC/IMM](#)

- **201-824-002 : Standalone Memory Test Aborted**

Node Interleave feature must be OFF. Go to Setup and disable Node Interleave option and then re-run the test.

**Recoverable**

No

**Severity**

Warning

**Serviceable**

No

**Automatically notify support**

No

**User Response**

Complete the following steps:

1. Perform the actions mentioned one at a time and try the test after each action.
2. If the problem remains, contact your technical-service representative.
3. Turn off the system and disconnect it from power. Wait for 45 seconds. Reseat DIMM(s). Reconnect it to power.
4. Make sure that DSA and BIOS/uEFI are at the latest level.

**Related links**

- [IBM Support website](#)
- [Latest level of DSA](#)
- [Latest level of BMC/IMM](#)

- **201-824-003 : Standalone Memory Test Aborted**

Node Interleave feature must be OFF. Go to Setup and disable Node Interleave option and then re-run the test.

**Recoverable**

No

**Severity**

Warning

**Serviceable**

No

**Automatically notify support**

No

**User Response**

Complete the following steps:

1. Perform the actions mentioned one at a time and try the test after each action.
2. If the problem remains, contact your technical-service representative.
3. Turn off the system and disconnect it from power. Wait for 45 seconds. Reseat DIMM(s). Reconnect it to power.
4. Make sure that DSA and BIOS/uEFI are at the latest level.

**Related links**

- [IBM Support website](#)
- [Latest level of DSA](#)
- [Latest level of BMC/IMM](#)

- **201-826-000 : Standalone Memory Test Aborted**

BIOS: Memory Controller has been disabled. Go to Setup and Enable Memory Controller.

**Recoverable**

No

**Severity**

Warning

**Serviceable**

No

**Automatically notify support**

No

**User Response**

Complete the following steps:

1. Perform the actions mentioned one at a time and try the test after each action.
2. If the problem remains, contact your technical-service representative.
3. Turn off the system and disconnect it from power. Wait for 45 seconds. Reseat DIMM(s). Reconnect it to power.
4. Make sure that DSA and BIOS/uEFI are at the latest level.

**Related links**

- [IBM Support website](#)
- [Latest level of DSA](#)
- [Latest level of BMC/IMM](#)

- **201-826-001 : Standalone Memory Test Aborted**

BIOS: Memory Controller has been disabled. Go to Setup and Enable Memory Controller.

**Recoverable**

No

**Severity**

Warning

**Serviceable**

No

**Automatically notify support**

No

### User Response

Complete the following steps:

1. Perform the actions mentioned one at a time and try the test after each action.
2. If the problem remains, contact your technical-service representative.
3. Turn off the system and disconnect it from power. Wait for 45 seconds. Reseat DIMM(s). Reconnect it to power.
4. Make sure that DSA and BIOS/uEFI are at the latest level.

### Related links

- [IBM Support website](#)
- [Latest level of DSA](#)
- [Latest level of BMC/IMM](#)

- **201-826-002 : Standalone Memory Test Aborted**

BIOS: Memory Controller has been disabled. Go to Setup and Enable Memory Controller.

### Recoverable

No

### Severity

Warning

### Serviceable

No

### Automatically notify support

No

### User Response

Complete the following steps:

1. Perform the actions mentioned one at a time and try the test after each action.
2. If the problem remains, contact your technical-service representative.
3. Turn off the system and disconnect it from power. Wait for 45 seconds. Reseat DIMM(s). Reconnect it to power.
4. Make sure that DSA and BIOS/uEFI are at the latest level.

### Related links

- [IBM Support website](#)
- [Latest level of DSA](#)
- [Latest level of BMC/IMM](#)

- **201-826-003 : Standalone Memory Test Aborted**

BIOS: Memory Controller has been disabled. Go to Setup and Enable Memory Controller.

### Recoverable

No

### Severity

Warning

### Serviceable

No

### Automatically notify support

No

### User Response

Complete the following steps:



1. Perform the actions mentioned one at a time and try the test after each action.
2. If the problem remains, contact your technical-service representative.
3. Turn off the system and disconnect it from power. Wait for 45 seconds. Reseat DIMM(s). Reconnect it to power.
4. Make sure that DSA and BIOS/uEFI are at the latest level.

**Related links**

- [IBM Support website](#)
- [Latest level of DSA](#)
- [Latest level of BMC/IMM](#)

- **201-827-000 : Standalone Memory Test Aborted**

BIOS: ECC function has been disabled by BIOS. Go to Setup and enable ECC generation.

**Recoverable**

No

**Severity**

Warning

**Serviceable**

No

**Automatically notify support**

No

**User Response**

Complete the following steps:

1. Perform the actions mentioned one at a time and try the test after each action.
2. If the problem remains, contact your technical-service representative.
3. Turn off the system and disconnect it from power. Wait for 45 seconds. Reseat DIMM(s). Reconnect it to power.
4. Make sure that DSA and BIOS/uEFI are at the latest level.

**Related links**

- [IBM Support website](#)
- [Latest level of DSA](#)
- [Latest level of BMC/IMM](#)

- **201-827-001 : Standalone Memory Test Aborted**

BIOS: ECC function has been disabled by BIOS. Go to Setup and enable ECC generation.

**Recoverable**

No

**Severity**

Warning

**Serviceable**

No

**Automatically notify support**

No

**User Response**

Complete the following steps:

1. Perform the actions mentioned one at a time and try the test after each action.
2. If the problem remains, contact your technical-service representative.

3. Turn off the system and disconnect it from power. Wait for 45 seconds. Reseat DIMM(s). Reconnect it to power.
4. Make sure that DSA and BIOS/uEFI are at the latest level.

**Related links**

- [IBM Support website](#)
- [Latest level of DSA](#)
- [Latest level of BMC/IMM](#)

- **201-827-002 : Standalone Memory Test Aborted**

BIOS: ECC function has been disabled by BIOS. Go to Setup and enable ECC generation.

**Recoverable**

No

**Severity**

Warning

**Serviceable**

No

**Automatically notify support**

No

**User Response**

Complete the following steps:

1. Perform the actions mentioned one at a time and try the test after each action.
2. If the problem remains, contact your technical-service representative.
3. Turn off the system and disconnect it from power. Wait for 45 seconds. Reseat DIMM(s). Reconnect it to power.
4. Make sure that DSA and BIOS/uEFI are at the latest level.

**Related links**

- [IBM Support website](#)
- [Latest level of DSA](#)
- [Latest level of BMC/IMM](#)

- **201-827-003 : Standalone Memory Test Aborted**

BIOS: ECC function has been disabled by BIOS. Go to Setup and enable ECC generation.

**Recoverable**

No

**Severity**

Warning

**Serviceable**

No

**Automatically notify support**

No

**User Response**

Complete the following steps:

1. Perform the actions mentioned one at a time and try the test after each action.
2. If the problem remains, contact your technical-service representative.
3. Turn off the system and disconnect it from power. Wait for 45 seconds. Reseat DIMM(s). Reconnect it to power.

4. Make sure that DSA and BIOS/uEFI are at the latest level.

**Related links**

- [IBM Support website](#)
- [Latest level of DSA](#)
- [Latest level of BMC/IMM](#)

- **201-844-000 : Standalone Memory Test Aborted**

Chipset Error: Problem in masking MSR machine check control MASK registers.

**Recoverable**

No

**Severity**

Warning

**Serviceable**

No

**Automatically notify support**

No

**User Response**

Complete the following steps:

1. Perform the actions mentioned one at a time and try the test after each action.
2. If the problem remains, contact your technical-service representative.
3. Turn off the system and disconnect it from power. Wait for 45 seconds. Reseat DIMM(s). Reconnect it to power.
4. Make sure that DSA and BIOS/uEFI are at the latest level.

**Related links**

- [IBM Support website](#)
- [Latest level of DSA](#)
- [Latest level of BMC/IMM](#)

- **201-844-001 : Standalone Memory Test Aborted**

Chipset Error: Problem in masking MSR machine check control MASK registers.

**Recoverable**

No

**Severity**

Warning

**Serviceable**

No

**Automatically notify support**

No

**User Response**

Complete the following steps:

1. Perform the actions mentioned one at a time and try the test after each action.
2. If the problem remains, contact your technical-service representative.
3. Turn off the system and disconnect it from power. Wait for 45 seconds. Reseat DIMM(s). Reconnect it to power.
4. Make sure that DSA and BIOS/uEFI are at the latest level.

**Related links**

- [IBM Support website](#)
- [Latest level of DSA](#)
- [Latest level of BMC/IMM](#)

- **201-844-002 : Standalone Memory Test Aborted**

Chipset Error: Problem in masking MSR machine check control MASK registers.

**Recoverable**

No

**Severity**

Warning

**Serviceable**

No

**Automatically notify support**

No

**User Response**

Complete the following steps:

1. Perform the actions mentioned one at a time and try the test after each action.
2. If the problem remains, contact your technical-service representative.
3. Turn off the system and disconnect it from power. Wait for 45 seconds. Reseat DIMM(s). Reconnect it to power.
4. Make sure that DSA and BIOS/uEFI are at the latest level.

**Related links**

- [IBM Support website](#)
- [Latest level of DSA](#)
- [Latest level of BMC/IMM](#)

- **201-844-003 : Standalone Memory Test Aborted**

Chipset Error: Problem in masking MSR machine check control MASK registers.

**Recoverable**

No

**Severity**

Warning

**Serviceable**

No

**Automatically notify support**

No

**User Response**

Complete the following steps:

1. Perform the actions mentioned one at a time and try the test after each action.
2. If the problem remains, contact your technical-service representative.
3. Turn off the system and disconnect it from power. Wait for 45 seconds. Reseat DIMM(s). Reconnect it to power.
4. Make sure that DSA and BIOS/uEFI are at the latest level.

**Related links**

- [IBM Support website](#)
- [Latest level of DSA](#)

- [Latest level of BMC/IMM](#)
- **201-845-000 : Standalone Memory Test Aborted**  
Chipset Error: Problem clearing MSR machine check control registers.

**Recoverable**

No

**Severity**

Warning

**Serviceable**

No

**Automatically notify support**

No

**User Response**

Complete the following steps:

1. Perform the actions mentioned one at a time and try the test after each action.
2. If the problem remains, contact your technical-service representative.
3. Turn off the system and disconnect it from power. Wait for 45 seconds. Reseat DIMM(s). Reconnect it to power.
4. Make sure that DSA and BIOS/uEFI are at the latest level.

**Related links**

- [IBM Support website](#)
- [Latest level of DSA](#)
- [Latest level of BMC/IMM](#)
- **201-845-001 : Standalone Memory Test Aborted**  
Chipset Error: Problem clearing MSR machine check control registers.

**Recoverable**

No

**Severity**

Warning

**Serviceable**

No

**Automatically notify support**

No

**User Response**

Complete the following steps:

1. Perform the actions mentioned one at a time and try the test after each action.
2. If the problem remains, contact your technical-service representative.
3. Turn off the system and disconnect it from power. Wait for 45 seconds. Reseat DIMM(s). Reconnect it to power.
4. Make sure that DSA and BIOS/uEFI are at the latest level.

**Related links**

- [IBM Support website](#)
- [Latest level of DSA](#)
- [Latest level of BMC/IMM](#)
- **201-845-002 : Standalone Memory Test Aborted**

Chipset Error: Problem clearing MSR machine check control registers.

**Recoverable**

No

**Severity**

Warning

**Serviceable**

No

**Automatically notify support**

No

**User Response**

Complete the following steps:

1. Perform the actions mentioned one at a time and try the test after each action.
2. If the problem remains, contact your technical-service representative.
3. Turn off the system and disconnect it from power. Wait for 45 seconds. Reseat DIMM(s). Reconnect it to power.
4. Make sure that DSA and BIOS/uEFI are at the latest level.

**Related links**

- [IBM Support website](#)
- [Latest level of DSA](#)
- [Latest level of BMC/IMM](#)

• **201-845-003 : Standalone Memory Test Aborted**

Chipset Error: Problem clearing MSR machine check control registers.

**Recoverable**

No

**Severity**

Warning

**Serviceable**

No

**Automatically notify support**

No

**User Response**

Complete the following steps:

1. Perform the actions mentioned one at a time and try the test after each action.
2. If the problem remains, contact your technical-service representative.
3. Turn off the system and disconnect it from power. Wait for 45 seconds. Reseat DIMM(s). Reconnect it to power.
4. Make sure that DSA and BIOS/uEFI are at the latest level.

**Related links**

- [IBM Support website](#)
- [Latest level of DSA](#)
- [Latest level of BMC/IMM](#)

• **201-859-000 : Standalone Memory Test Aborted**

INVALID XSECSRAT type.

**Recoverable**

No

**Severity**

Warning

**Serviceable**

No

**Automatically notify support**

No

**User Response**

Complete the following steps:

1. Perform the actions mentioned one at a time and try the test after each action.
2. If the problem remains, contact your technical-service representative.
3. Turn off the system and disconnect it from power. Wait for 45 seconds. Reseat DIMM(s). Reconnect it to power.
4. Make sure that DSA and BIOS/uEFI are at the latest level.

**Related links**

- [IBM Support website](#)
- [Latest level of DSA](#)
- [Latest level of BMC/IMM](#)

- **201-859-001 : Standalone Memory Test Aborted**

INVALID XSECSRAT type.

**Recoverable**

No

**Severity**

Warning

**Serviceable**

No

**Automatically notify support**

No

**User Response**

Complete the following steps:

1. Perform the actions mentioned one at a time and try the test after each action.
2. If the problem remains, contact your technical-service representative.
3. Turn off the system and disconnect it from power. Wait for 45 seconds. Reseat DIMM(s). Reconnect it to power.
4. Make sure that DSA and BIOS/uEFI are at the latest level.

**Related links**

- [IBM Support website](#)
- [Latest level of DSA](#)
- [Latest level of BMC/IMM](#)

- **201-859-002 : Standalone Memory Test Aborted**

INVALID XSECSRAT type.

**Recoverable**

No

**Severity**

Warning

**Serviceable**

No

**Automatically notify support**

No

**User Response**

Complete the following steps:

1. Perform the actions mentioned one at a time and try the test after each action.
2. If the problem remains, contact your technical-service representative.
3. Turn off the system and disconnect it from power. Wait for 45 seconds. Reseat DIMM(s). Reconnect it to power.
4. Make sure that DSA and BIOS/uEFI are at the latest level.

**Related links**

- [IBM Support website](#)
- [Latest level of DSA](#)
- [Latest level of BMC/IMM](#)

- **201-859-003 : Standalone Memory Test Aborted**

INVALID XSECSRAT type.

**Recoverable**

No

**Severity**

Warning

**Serviceable**

No

**Automatically notify support**

No

**User Response**

Complete the following steps:

1. Perform the actions mentioned one at a time and try the test after each action.
2. If the problem remains, contact your technical-service representative.
3. Turn off the system and disconnect it from power. Wait for 45 seconds. Reseat DIMM(s). Reconnect it to power.
4. Make sure that DSA and BIOS/uEFI are at the latest level.

**Related links**

- [IBM Support website](#)
- [Latest level of DSA](#)
- [Latest level of BMC/IMM](#)

- **201-860-000 : Standalone Memory Test Aborted**

No OEM0 type 1 found.

**Recoverable**

No

**Severity**

Warning



**Serviceable**

No

**Automatically notify support**

No

**User Response**

Complete the following steps:

1. Perform the actions mentioned one at a time and try the test after each action.
2. If the problem remains, contact your technical-service representative.
3. Turn off the system and disconnect it from power. Wait for 45 seconds. Reseat DIMM(s). Reconnect it to power.
4. Make sure that DSA and BIOS/uEFI are at the latest level.

**Related links**

- [IBM Support website](#)
- [Latest level of DSA](#)
- [Latest level of BMC/IMM](#)

- **201-860-001 : Standalone Memory Test Aborted**

No OEM0 type 1 found.

**Recoverable**

No

**Severity**

Warning

**Serviceable**

No

**Automatically notify support**

No

**User Response**

Complete the following steps:

1. Perform the actions mentioned one at a time and try the test after each action.
2. If the problem remains, contact your technical-service representative.
3. Turn off the system and disconnect it from power. Wait for 45 seconds. Reseat DIMM(s). Reconnect it to power.
4. Make sure that DSA and BIOS/uEFI are at the latest level.

**Related links**

- [IBM Support website](#)
- [Latest level of DSA](#)
- [Latest level of BMC/IMM](#)

- **201-860-002 : Standalone Memory Test Aborted**

No OEM0 type 1 found.

**Recoverable**

No

**Severity**

Warning

**Serviceable**

No

**Automatically notify support**

No

**User Response**

Complete the following steps:

1. Perform the actions mentioned one at a time and try the test after each action.
2. If the problem remains, contact your technical-service representative.
3. Turn off the system and disconnect it from power. Wait for 45 seconds. Reseat DIMM(s). Reconnect it to power.
4. Make sure that DSA and BIOS/uEFI are at the latest level.

**Related links**

- [IBM Support website](#)
- [Latest level of DSA](#)
- [Latest level of BMC/IMM](#)

- **201-860-003 : Standalone Memory Test Aborted**

No OEM0 type 1 found.

**Recoverable**

No

**Severity**

Warning

**Serviceable**

No

**Automatically notify support**

No

**User Response**

Complete the following steps:

1. Perform the actions mentioned one at a time and try the test after each action.
2. If the problem remains, contact your technical-service representative.
3. Turn off the system and disconnect it from power. Wait for 45 seconds. Reseat DIMM(s). Reconnect it to power.
4. Make sure that DSA and BIOS/uEFI are at the latest level.

**Related links**

- [IBM Support website](#)
- [Latest level of DSA](#)
- [Latest level of BMC/IMM](#)

- **201-861-000 : Standalone Memory Test Aborted**

No SRAT type 1 found.

**Recoverable**

No

**Severity**

Warning

**Serviceable**

No

**Automatically notify support**

No

**User Response**

Complete the following steps:

1. Perform the actions mentioned one at a time and try the test after each action.
2. If the problem remains, contact your technical-service representative.
3. Turn off the system and disconnect it from power. Wait for 45 seconds. Reseat DIMM(s). Reconnect it to power.
4. Make sure that DSA and BIOS/uEFI are at the latest level.

**Related links**

- [IBM Support website](#)
- [Latest level of DSA](#)
- [Latest level of BMC/IMM](#)

- **201-861-001 : Standalone Memory Test Aborted**

No SRAT type 1 found.

**Recoverable**

No

**Severity**

Warning

**Serviceable**

No

**Automatically notify support**

No

**User Response**

Complete the following steps:

1. Perform the actions mentioned one at a time and try the test after each action.
2. If the problem remains, contact your technical-service representative.
3. Turn off the system and disconnect it from power. Wait for 45 seconds. Reseat DIMM(s). Reconnect it to power.
4. Make sure that DSA and BIOS/uEFI are at the latest level.

**Related links**

- [IBM Support website](#)
- [Latest level of DSA](#)
- [Latest level of BMC/IMM](#)

- **201-861-002 : Standalone Memory Test Aborted**

No SRAT type 1 found.

**Recoverable**

No

**Severity**

Warning

**Serviceable**

No

**Automatically notify support**

No

**User Response**

Complete the following steps:

1. Perform the actions mentioned one at a time and try the test after each action.
2. If the problem remains, contact your technical-service representative.
3. Turn off the system and disconnect it from power. Wait for 45 seconds. Reseat DIMM(s). Reconnect it to power.
4. Make sure that DSA and BIOS/uEFI are at the latest level.

**Related links**

- [IBM Support website](#)
- [Latest level of DSA](#)
- [Latest level of BMC/IMM](#)

**• 201-861-003 : Standalone Memory Test Aborted**

No SRAT type 1 found.

**Recoverable**

No

**Severity**

Warning

**Serviceable**

No

**Automatically notify support**

No

**User Response**

Complete the following steps:

1. Perform the actions mentioned one at a time and try the test after each action.
2. If the problem remains, contact your technical-service representative.
3. Turn off the system and disconnect it from power. Wait for 45 seconds. Reseat DIMM(s). Reconnect it to power.
4. Make sure that DSA and BIOS/uEFI are at the latest level.

**Related links**

- [IBM Support website](#)
- [Latest level of DSA](#)
- [Latest level of BMC/IMM](#)

**• 201-862-000 : Standalone Memory Test Aborted**

No OEM1 structure found.

**Recoverable**

No

**Severity**

Warning

**Serviceable**

No

**Automatically notify support**

No

**User Response**

Complete the following steps:

1. Perform the actions mentioned one at a time and try the test after each action.
2. If the problem remains, contact your technical-service representative.

3. Turn off the system and disconnect it from power. Wait for 45 seconds. Reseat DIMM(s). Reconnect it to power.
4. Make sure that DSA and BIOS/uEFI are at the latest level.

**Related links**

- [IBM Support website](#)
- [Latest level of DSA](#)
- [Latest level of BMC/IMM](#)

- **201-862-001 : Standalone Memory Test Aborted**

No OEM1 structure found.

**Recoverable**

No

**Severity**

Warning

**Serviceable**

No

**Automatically notify support**

No

**User Response**

Complete the following steps:

1. Perform the actions mentioned one at a time and try the test after each action.
2. If the problem remains, contact your technical-service representative.
3. Turn off the system and disconnect it from power. Wait for 45 seconds. Reseat DIMM(s). Reconnect it to power.
4. Make sure that DSA and BIOS/uEFI are at the latest level.

**Related links**

- [IBM Support website](#)
- [Latest level of DSA](#)
- [Latest level of BMC/IMM](#)

- **201-862-002 : Standalone Memory Test Aborted**

No OEM1 structure found.

**Recoverable**

No

**Severity**

Warning

**Serviceable**

No

**Automatically notify support**

No

**User Response**

Complete the following steps:

1. Perform the actions mentioned one at a time and try the test after each action.
2. If the problem remains, contact your technical-service representative.
3. Turn off the system and disconnect it from power. Wait for 45 seconds. Reseat DIMM(s). Reconnect it to power.

4. Make sure that DSA and BIOS/uEFI are at the latest level.

**Related links**

- [IBM Support website](#)
- [Latest level of DSA](#)
- [Latest level of BMC/IMM](#)

- **201-862-003 : Standalone Memory Test Aborted**

No OEM1 structure found.

**Recoverable**

No

**Severity**

Warning

**Serviceable**

No

**Automatically notify support**

No

**User Response**

Complete the following steps:

1. Perform the actions mentioned one at a time and try the test after each action.
2. If the problem remains, contact your technical-service representative.
3. Turn off the system and disconnect it from power. Wait for 45 seconds. Reseat DIMM(s). Reconnect it to power.
4. Make sure that DSA and BIOS/uEFI are at the latest level.

**Related links**

- [IBM Support website](#)
- [Latest level of DSA](#)
- [Latest level of BMC/IMM](#)

- **201-863-000 : Standalone Memory Test Aborted**

No IBMERROR key in OEM1 structure.

**Recoverable**

No

**Severity**

Warning

**Serviceable**

No

**Automatically notify support**

No

**User Response**

Complete the following steps:

1. Perform the actions mentioned one at a time and try the test after each action.
2. If the problem remains, contact your technical-service representative.
3. Turn off the system and disconnect it from power. Wait for 45 seconds. Reseat DIMM(s). Reconnect it to power.
4. Make sure that DSA and BIOS/uEFI are at the latest level.

**Related links**

- [IBM Support website](#)
- [Latest level of DSA](#)
- [Latest level of BMC/IMM](#)

- **201-863-001 : Standalone Memory Test Aborted**

No IBMERROR key in OEM1 structure.

**Recoverable**

No

**Severity**

Warning

**Serviceable**

No

**Automatically notify support**

No

**User Response**

Complete the following steps:

1. Perform the actions mentioned one at a time and try the test after each action.
2. If the problem remains, contact your technical-service representative.
3. Turn off the system and disconnect it from power. Wait for 45 seconds. Reseat DIMM(s). Reconnect it to power.
4. Make sure that DSA and BIOS/uEFI are at the latest level.

**Related links**

- [IBM Support website](#)
- [Latest level of DSA](#)
- [Latest level of BMC/IMM](#)

- **201-863-002 : Standalone Memory Test Aborted**

No IBMERROR key in OEM1 structure.

**Recoverable**

No

**Severity**

Warning

**Serviceable**

No

**Automatically notify support**

No

**User Response**

Complete the following steps:

1. Perform the actions mentioned one at a time and try the test after each action.
2. If the problem remains, contact your technical-service representative.
3. Turn off the system and disconnect it from power. Wait for 45 seconds. Reseat DIMM(s). Reconnect it to power.
4. Make sure that DSA and BIOS/uEFI are at the latest level.

**Related links**

- [IBM Support website](#)
- [Latest level of DSA](#)

- [Latest level of BMC/IMM](#)

- **201-863-003 : Standalone Memory Test Aborted**

No IBMERROR key in OEM1 structure.

**Recoverable**

No

**Severity**

Warning

**Serviceable**

No

**Automatically notify support**

No

**User Response**

Complete the following steps:

1. Perform the actions mentioned one at a time and try the test after each action.
2. If the problem remains, contact your technical-service representative.
3. Turn off the system and disconnect it from power. Wait for 45 seconds. Reseat DIMM(s). Reconnect it to power.
4. Make sure that DSA and BIOS/uEFI are at the latest level.

**Related links**

- [IBM Support website](#)
- [Latest level of DSA](#)
- [Latest level of BMC/IMM](#)

- **201-864-000 : Standalone Memory Test Aborted**

No GAS located in OEM1.

**Recoverable**

No

**Severity**

Warning

**Serviceable**

No

**Automatically notify support**

No

**User Response**

Complete the following steps:

1. Perform the actions mentioned one at a time and try the test after each action.
2. If the problem remains, contact your technical-service representative.
3. Turn off the system and disconnect it from power. Wait for 45 seconds. Reseat DIMM(s). Reconnect it to power.
4. Make sure that DSA and BIOS/uEFI are at the latest level.

**Related links**

- [IBM Support website](#)
- [Latest level of DSA](#)
- [Latest level of BMC/IMM](#)

- **201-864-001 : Standalone Memory Test Aborted**



No GAS located in OEM1.

**Recoverable**

No

**Severity**

Warning

**Serviceable**

No

**Automatically notify support**

No

**User Response**

Complete the following steps:

1. Perform the actions mentioned one at a time and try the test after each action.
2. If the problem remains, contact your technical-service representative.
3. Turn off the system and disconnect it from power. Wait for 45 seconds. Reseat DIMM(s). Reconnect it to power.
4. Make sure that DSA and BIOS/uEFI are at the latest level.

**Related links**

- [IBM Support website](#)
- [Latest level of DSA](#)
- [Latest level of BMC/IMM](#)

• **201-864-002 : Standalone Memory Test Aborted**

No GAS located in OEM1.

**Recoverable**

No

**Severity**

Warning

**Serviceable**

No

**Automatically notify support**

No

**User Response**

Complete the following steps:

1. Perform the actions mentioned one at a time and try the test after each action.
2. If the problem remains, contact your technical-service representative.
3. Turn off the system and disconnect it from power. Wait for 45 seconds. Reseat DIMM(s). Reconnect it to power.
4. Make sure that DSA and BIOS/uEFI are at the latest level.

**Related links**

- [IBM Support website](#)
- [Latest level of DSA](#)
- [Latest level of BMC/IMM](#)

• **201-864-003 : Standalone Memory Test Aborted**

No GAS located in OEM1.

**Recoverable**

No

**Severity**

Warning

**Serviceable**

No

**Automatically notify support**

No

**User Response**

Complete the following steps:

1. Perform the actions mentioned one at a time and try the test after each action.
2. If the problem remains, contact your technical-service representative.
3. Turn off the system and disconnect it from power. Wait for 45 seconds. Reseat DIMM(s). Reconnect it to power.
4. Make sure that DSA and BIOS/uEFI are at the latest level.

**Related links**

- [IBM Support website](#)
- [Latest level of DSA](#)
- [Latest level of BMC/IMM](#)

- **201-865-000 : Standalone Memory Test Aborted**

No XSECSRAT key in OEM0 structure.

**Recoverable**

No

**Severity**

Warning

**Serviceable**

No

**Automatically notify support**

No

**User Response**

Complete the following steps:

1. Perform the actions mentioned one at a time and try the test after each action.
2. If the problem remains, contact your technical-service representative.
3. Turn off the system and disconnect it from power. Wait for 45 seconds. Reseat DIMM(s). Reconnect it to power.
4. Make sure that DSA and BIOS/uEFI are at the latest level.

**Related links**

- [IBM Support website](#)
- [Latest level of DSA](#)
- [Latest level of BMC/IMM](#)

- **201-865-001 : Standalone Memory Test Aborted**

No XSECSRAT key in OEM0 structure.

**Recoverable**

No

**Severity**

Warning

**Serviceable**

No

**Automatically notify support**

No

**User Response**

Complete the following steps:

1. Perform the actions mentioned one at a time and try the test after each action.
2. If the problem remains, contact your technical-service representative.
3. Turn off the system and disconnect it from power. Wait for 45 seconds. Reseat DIMM(s). Reconnect it to power.
4. Make sure that DSA and BIOS/uEFI are at the latest level.

**Related links**

- [IBM Support website](#)
- [Latest level of DSA](#)
- [Latest level of BMC/IMM](#)

- **201-865-002 : Standalone Memory Test Aborted**

No XSECSRAT key in OEM0 structure.

**Recoverable**

No

**Severity**

Warning

**Serviceable**

No

**Automatically notify support**

No

**User Response**

Complete the following steps:

1. Perform the actions mentioned one at a time and try the test after each action.
2. If the problem remains, contact your technical-service representative.
3. Turn off the system and disconnect it from power. Wait for 45 seconds. Reseat DIMM(s). Reconnect it to power.
4. Make sure that DSA and BIOS/uEFI are at the latest level.

**Related links**

- [IBM Support website](#)
- [Latest level of DSA](#)
- [Latest level of BMC/IMM](#)

- **201-865-003 : Standalone Memory Test Aborted**

No XSECSRAT key in OEM0 structure.

**Recoverable**

No

**Severity**

Warning

**Serviceable**

No

**Automatically notify support**

No

**User Response**

Complete the following steps:

1. Perform the actions mentioned one at a time and try the test after each action.
2. If the problem remains, contact your technical-service representative.
3. Turn off the system and disconnect it from power. Wait for 45 seconds. Reseat DIMM(s). Reconnect it to power.
4. Make sure that DSA and BIOS/uEFI are at the latest level.

**Related links**

- [IBM Support website](#)
- [Latest level of DSA](#)
- [Latest level of BMC/IMM](#)

- **201-866-000 : Standalone Memory Test Aborted**

EFI-SAL Invalid parameter from GetMemoryMap function.

**Recoverable**

No

**Severity**

Warning

**Serviceable**

No

**Automatically notify support**

No

**User Response**

Complete the following steps:

1. Perform the actions mentioned one at a time and try the test after each action.
2. If the problem remains, contact your technical-service representative.
3. Turn off the system and disconnect it from power. Wait for 45 seconds. Reseat DIMM(s). Reconnect it to power.
4. Make sure that DSA and BIOS/uEFI are at the latest level.

**Related links**

- [IBM Support website](#)
- [Latest level of DSA](#)
- [Latest level of BMC/IMM](#)

- **201-866-001 : Standalone Memory Test Aborted**

EFI-SAL Invalid parameter from GetMemoryMap function.

**Recoverable**

No

**Severity**

Warning

**Serviceable**

No

**Automatically notify support**

No

**User Response**

Complete the following steps:

1. Perform the actions mentioned one at a time and try the test after each action.
2. If the problem remains, contact your technical-service representative.
3. Turn off the system and disconnect it from power. Wait for 45 seconds. Reseat DIMM(s). Reconnect it to power.
4. Make sure that DSA and BIOS/uEFI are at the latest level.

**Related links**

- [IBM Support website](#)
- [Latest level of DSA](#)
- [Latest level of BMC/IMM](#)

- **201-866-002 : Standalone Memory Test Aborted**

EFI-SAL Invalid parameter from GetMemoryMap function.

**Recoverable**

No

**Severity**

Warning

**Serviceable**

No

**Automatically notify support**

No

**User Response**

Complete the following steps:

1. Perform the actions mentioned one at a time and try the test after each action.
2. If the problem remains, contact your technical-service representative.
3. Turn off the system and disconnect it from power. Wait for 45 seconds. Reseat DIMM(s). Reconnect it to power.
4. Make sure that DSA and BIOS/uEFI are at the latest level.

**Related links**

- [IBM Support website](#)
- [Latest level of DSA](#)
- [Latest level of BMC/IMM](#)

- **201-866-003 : Standalone Memory Test Aborted**

EFI-SAL Invalid parameter from GetMemoryMap function.

**Recoverable**

No

**Severity**

Warning

**Serviceable**

No

**Automatically notify support**

No

**User Response**

Complete the following steps:

1. Perform the actions mentioned one at a time and try the test after each action.
2. If the problem remains, contact your technical-service representative.
3. Turn off the system and disconnect it from power. Wait for 45 seconds. Reseat DIMM(s). Reconnect it to power.
4. Make sure that DSA and BIOS/uEFI are at the latest level.

**Related links**

- [IBM Support website](#)
- [Latest level of DSA](#)
- [Latest level of BMC/IMM](#)

- **201-867-000 : Standalone Memory Test Aborted**

EFI/SAL: Buffer not allocated.

**Recoverable**

No

**Severity**

Warning

**Serviceable**

No

**Automatically notify support**

No

**User Response**

Complete the following steps:

1. Perform the actions mentioned one at a time and try the test after each action.
2. If the problem remains, contact your technical-service representative.
3. Turn off the system and disconnect it from power. Wait for 45 seconds. Reseat DIMM(s). Reconnect it to power.
4. Make sure that DSA and BIOS/uEFI are at the latest level.

**Related links**

- [IBM Support website](#)
- [Latest level of DSA](#)
- [Latest level of BMC/IMM](#)

- **201-867-001 : Standalone Memory Test Aborted**

EFI/SAL: Buffer not allocated.

**Recoverable**

No

**Severity**

Warning

**Serviceable**

No

**Automatically notify support**

No

**User Response**

Complete the following steps:

1. Perform the actions mentioned one at a time and try the test after each action.
2. If the problem remains, contact your technical-service representative.
3. Turn off the system and disconnect it from power. Wait for 45 seconds. Reseat DIMM(s). Reconnect it to power.
4. Make sure that DSA and BIOS/uEFI are at the latest level.

**Related links**

- [IBM Support website](#)
- [Latest level of DSA](#)
- [Latest level of BMC/IMM](#)

- **201-867-002 : Standalone Memory Test Aborted**

EFI/SAL: Buffer not allocated.

**Recoverable**

No

**Severity**

Warning

**Serviceable**

No

**Automatically notify support**

No

**User Response**

Complete the following steps:

1. Perform the actions mentioned one at a time and try the test after each action.
2. If the problem remains, contact your technical-service representative.
3. Turn off the system and disconnect it from power. Wait for 45 seconds. Reseat DIMM(s). Reconnect it to power.
4. Make sure that DSA and BIOS/uEFI are at the latest level.

**Related links**

- [IBM Support website](#)
- [Latest level of DSA](#)
- [Latest level of BMC/IMM](#)

- **201-867-003 : Standalone Memory Test Aborted**

EFI/SAL: Buffer not allocated.

**Recoverable**

No

**Severity**

Warning

**Serviceable**

No

**Automatically notify support**

No

**User Response**

Complete the following steps:

1. Perform the actions mentioned one at a time and try the test after each action.
2. If the problem remains, contact your technical-service representative.

3. Turn off the system and disconnect it from power. Wait for 45 seconds. Reseat DIMM(s). Reconnect it to power.
4. Make sure that DSA and BIOS/uEFI are at the latest level.

**Related links**

- [IBM Support website](#)
- [Latest level of DSA](#)
- [Latest level of BMC/IMM](#)

- **201-868-000 : Standalone Memory Test Aborted**

EFI/SAL: Buffer allocated in GetMemoryMap too small.

**Recoverable**

No

**Severity**

Warning

**Serviceable**

No

**Automatically notify support**

No

**User Response**

Complete the following steps:

1. Perform the actions mentioned one at a time and try the test after each action.
2. If the problem remains, contact your technical-service representative.
3. Turn off the system and disconnect it from power. Wait for 45 seconds. Reseat DIMM(s). Reconnect it to power.
4. Make sure that DSA and BIOS/uEFI are at the latest level.

**Related links**

- [IBM Support website](#)
- [Latest level of DSA](#)
- [Latest level of BMC/IMM](#)

- **201-868-001 : Standalone Memory Test Aborted**

EFI/SAL: Buffer allocated in GetMemoryMap too small.

**Recoverable**

No

**Severity**

Warning

**Serviceable**

No

**Automatically notify support**

No

**User Response**

Complete the following steps:

1. Perform the actions mentioned one at a time and try the test after each action.
2. If the problem remains, contact your technical-service representative.
3. Turn off the system and disconnect it from power. Wait for 45 seconds. Reseat DIMM(s). Reconnect it to power.



4. Make sure that DSA and BIOS/uEFI are at the latest level.

**Related links**

- [IBM Support website](#)
- [Latest level of DSA](#)
- [Latest level of BMC/IMM](#)

- **201-868-002 : Standalone Memory Test Aborted**

EFI/SAL: Buffer allocated in GetMemoryMap too small.

**Recoverable**

No

**Severity**

Warning

**Serviceable**

No

**Automatically notify support**

No

**User Response**

Complete the following steps:

1. Perform the actions mentioned one at a time and try the test after each action.
2. If the problem remains, contact your technical-service representative.
3. Turn off the system and disconnect it from power. Wait for 45 seconds. Reseat DIMM(s). Reconnect it to power.
4. Make sure that DSA and BIOS/uEFI are at the latest level.

**Related links**

- [IBM Support website](#)
- [Latest level of DSA](#)
- [Latest level of BMC/IMM](#)

- **201-868-003 : Standalone Memory Test Aborted**

EFI/SAL: Buffer allocated in GetMemoryMap too small.

**Recoverable**

No

**Severity**

Warning

**Serviceable**

No

**Automatically notify support**

No

**User Response**

Complete the following steps:

1. Perform the actions mentioned one at a time and try the test after each action.
2. If the problem remains, contact your technical-service representative.
3. Turn off the system and disconnect it from power. Wait for 45 seconds. Reseat DIMM(s). Reconnect it to power.
4. Make sure that DSA and BIOS/uEFI are at the latest level.

**Related links**

- [IBM Support website](#)
- [Latest level of DSA](#)
- [Latest level of BMC/IMM](#)

- **201-869-000 : Standalone Memory Test Aborted**

EFI/SAL Invalid parameter from GetMemoryMap function.

**Recoverable**

No

**Severity**

Warning

**Serviceable**

No

**Automatically notify support**

No

**User Response**

Complete the following steps:

1. Perform the actions mentioned one at a time and try the test after each action.
2. If the problem remains, contact your technical-service representative.
3. Turn off the system and disconnect it from power. Wait for 45 seconds. Reseat DIMM(s). Reconnect it to power.
4. Make sure that DSA and BIOS/uEFI are at the latest level.

**Related links**

- [IBM Support website](#)
- [Latest level of DSA](#)
- [Latest level of BMC/IMM](#)

- **201-869-001 : Standalone Memory Test Aborted**

EFI/SAL Invalid parameter from GetMemoryMap function.

**Recoverable**

No

**Severity**

Warning

**Serviceable**

No

**Automatically notify support**

No

**User Response**

Complete the following steps:

1. Perform the actions mentioned one at a time and try the test after each action.
2. If the problem remains, contact your technical-service representative.
3. Turn off the system and disconnect it from power. Wait for 45 seconds. Reseat DIMM(s). Reconnect it to power.
4. Make sure that DSA and BIOS/uEFI are at the latest level.

**Related links**

- [IBM Support website](#)
- [Latest level of DSA](#)

- [Latest level of BMC/IMM](#)
- **201-869-002 : Standalone Memory Test Aborted**  
EFI/SAL Invalid parameter from GetMemoryMap function.

**Recoverable**

No

**Severity**

Warning

**Serviceable**

No

**Automatically notify support**

No

**User Response**

Complete the following steps:

1. Perform the actions mentioned one at a time and try the test after each action.
2. If the problem remains, contact your technical-service representative.
3. Turn off the system and disconnect it from power. Wait for 45 seconds. Reseat DIMM(s). Reconnect it to power.
4. Make sure that DSA and BIOS/uEFI are at the latest level.

**Related links**

- [IBM Support website](#)
- [Latest level of DSA](#)
- [Latest level of BMC/IMM](#)
- **201-869-003 : Standalone Memory Test Aborted**  
EFI/SAL Invalid parameter from GetMemoryMap function.

**Recoverable**

No

**Severity**

Warning

**Serviceable**

No

**Automatically notify support**

No

**User Response**

Complete the following steps:

1. Perform the actions mentioned one at a time and try the test after each action.
2. If the problem remains, contact your technical-service representative.
3. Turn off the system and disconnect it from power. Wait for 45 seconds. Reseat DIMM(s). Reconnect it to power.
4. Make sure that DSA and BIOS/uEFI are at the latest level.

**Related links**

- [IBM Support website](#)
- [Latest level of DSA](#)
- [Latest level of BMC/IMM](#)
- **201-870-000 : Standalone Memory Test Aborted**

CPU Doamin in ACPI not valid.

**Recoverable**

No

**Severity**

Warning

**Serviceable**

No

**Automatically notify support**

No

**User Response**

Complete the following steps:

1. Perform the actions mentioned one at a time and try the test after each action.
2. If the problem remains, contact your technical-service representative.
3. Turn off the system and disconnect it from power. Wait for 45 seconds. Reseat DIMM(s). Reconnect it to power.
4. Make sure that DSA and BIOS/uEFI are at the latest level.

**Related links**

- [IBM Support website](#)
- [Latest level of DSA](#)
- [Latest level of BMC/IMM](#)

• **201-870-001 : Standalone Memory Test Aborted**

CPU Doamin in ACPI not valid.

**Recoverable**

No

**Severity**

Warning

**Serviceable**

No

**Automatically notify support**

No

**User Response**

Complete the following steps:

1. Perform the actions mentioned one at a time and try the test after each action.
2. If the problem remains, contact your technical-service representative.
3. Turn off the system and disconnect it from power. Wait for 45 seconds. Reseat DIMM(s). Reconnect it to power.
4. Make sure that DSA and BIOS/uEFI are at the latest level.

**Related links**

- [IBM Support website](#)
- [Latest level of DSA](#)
- [Latest level of BMC/IMM](#)

• **201-870-002 : Standalone Memory Test Aborted**

CPU Doamin in ACPI not valid.

**Recoverable**

No

**Severity**

Warning

**Serviceable**

No

**Automatically notify support**

No

**User Response**

Complete the following steps:

1. Perform the actions mentioned one at a time and try the test after each action.
2. If the problem remains, contact your technical-service representative.
3. Turn off the system and disconnect it from power. Wait for 45 seconds. Reseat DIMM(s). Reconnect it to power.
4. Make sure that DSA and BIOS/uEFI are at the latest level.

**Related links**

- [IBM Support website](#)
- [Latest level of DSA](#)
- [Latest level of BMC/IMM](#)

- **201-870-003 : Standalone Memory Test Aborted**

CPU Doamin in ACPI not valid.

**Recoverable**

No

**Severity**

Warning

**Serviceable**

No

**Automatically notify support**

No

**User Response**

Complete the following steps:

1. Perform the actions mentioned one at a time and try the test after each action.
2. If the problem remains, contact your technical-service representative.
3. Turn off the system and disconnect it from power. Wait for 45 seconds. Reseat DIMM(s). Reconnect it to power.
4. Make sure that DSA and BIOS/uEFI are at the latest level.

**Related links**

- [IBM Support website](#)
- [Latest level of DSA](#)
- [Latest level of BMC/IMM](#)

- **201-871-000 : Standalone Memory Test Aborted**

Data Mis-compare encountered.

**Recoverable**

No

**Severity**

Warning

**Serviceable**

No

**Automatically notify support**

No

**User Response**

Complete the following steps:

1. Perform the actions mentioned one at a time and try the test after each action.
2. If the problem remains, contact your technical-service representative.
3. Turn off the system and disconnect it from power. Wait for 45 seconds. Reseat DIMM(s). Reconnect it to power.
4. Make sure that DSA and BIOS/uEFI are at the latest level.

**Related links**

- [IBM Support website](#)
- [Latest level of DSA](#)
- [Latest level of BMC/IMM](#)

- **201-871-001 : Standalone Memory Test Aborted**

Data Mis-compare encountered.

**Recoverable**

No

**Severity**

Warning

**Serviceable**

No

**Automatically notify support**

No

**User Response**

Complete the following steps:

1. Perform the actions mentioned one at a time and try the test after each action.
2. If the problem remains, contact your technical-service representative.
3. Turn off the system and disconnect it from power. Wait for 45 seconds. Reseat DIMM(s). Reconnect it to power.
4. Make sure that DSA and BIOS/uEFI are at the latest level.

**Related links**

- [IBM Support website](#)
- [Latest level of DSA](#)
- [Latest level of BMC/IMM](#)

- **201-871-002 : Standalone Memory Test Aborted**

Data Mis-compare encountered.

**Recoverable**

No

**Severity**

Warning

**Serviceable**

No

**Automatically notify support**

No

**User Response**

Complete the following steps:

1. Perform the actions mentioned one at a time and try the test after each action.
2. If the problem remains, contact your technical-service representative.
3. Turn off the system and disconnect it from power. Wait for 45 seconds. Reseat DIMM(s). Reconnect it to power.
4. Make sure that DSA and BIOS/uEFI are at the latest level.

**Related links**

- [IBM Support website](#)
- [Latest level of DSA](#)
- [Latest level of BMC/IMM](#)

- **201-871-003 : Standalone Memory Test Aborted**

Data Mis-compare encountered.

**Recoverable**

No

**Severity**

Warning

**Serviceable**

No

**Automatically notify support**

No

**User Response**

Complete the following steps:

1. Perform the actions mentioned one at a time and try the test after each action.
2. If the problem remains, contact your technical-service representative.
3. Turn off the system and disconnect it from power. Wait for 45 seconds. Reseat DIMM(s). Reconnect it to power.
4. Make sure that DSA and BIOS/uEFI are at the latest level.

**Related links**

- [IBM Support website](#)
- [Latest level of DSA](#)
- [Latest level of BMC/IMM](#)

- **201-877-000 : Standalone Memory Test Aborted**

BIOS: Sparing in Extended PCI reg. must be OFF. Go to setup and disable sparing.

**Recoverable**

No

**Severity**

Warning

**Serviceable**

No

**Automatically notify support**

No

**User Response**

Complete the following steps:

1. Perform the actions mentioned one at a time and try the test after each action.
2. If the problem remains, contact your technical-service representative.
3. Turn off the system and disconnect it from power. Wait for 45 seconds. Reseat DIMM(s). Reconnect it to power.
4. Make sure that DSA and BIOS/uEFI are at the latest level.

**Related links**

- [IBM Support website](#)
- [Latest level of DSA](#)
- [Latest level of BMC/IMM](#)

- **201-877-001 : Standalone Memory Test Aborted**

BIOS: Sparing in Extended PCI reg. must be OFF. Go to setup and disable sparing.

**Recoverable**

No

**Severity**

Warning

**Serviceable**

No

**Automatically notify support**

No

**User Response**

Complete the following steps:

1. Perform the actions mentioned one at a time and try the test after each action.
2. If the problem remains, contact your technical-service representative.
3. Turn off the system and disconnect it from power. Wait for 45 seconds. Reseat DIMM(s). Reconnect it to power.
4. Make sure that DSA and BIOS/uEFI are at the latest level.

**Related links**

- [IBM Support website](#)
- [Latest level of DSA](#)
- [Latest level of BMC/IMM](#)

- **201-877-002 : Standalone Memory Test Aborted**

BIOS: Sparing in Extended PCI reg. must be OFF. Go to setup and disable sparing.

**Recoverable**

No

**Severity**

Warning

**Serviceable**

No

**Automatically notify support**

No



**User Response**

Complete the following steps:

1. Perform the actions mentioned one at a time and try the test after each action.
2. If the problem remains, contact your technical-service representative.
3. Turn off the system and disconnect it from power. Wait for 45 seconds. Reseat DIMM(s). Reconnect it to power.
4. Make sure that DSA and BIOS/uEFI are at the latest level.

**Related links**

- [IBM Support website](#)
- [Latest level of DSA](#)
- [Latest level of BMC/IMM](#)

- **201-877-003 : Standalone Memory Test Aborted**

BIOS: Sparing in Extended PCI reg. must be OFF. Go to setup and disable sparing.

**Recoverable**

No

**Severity**

Warning

**Serviceable**

No

**Automatically notify support**

No

**User Response**

Complete the following steps:

1. Perform the actions mentioned one at a time and try the test after each action.
2. If the problem remains, contact your technical-service representative.
3. Turn off the system and disconnect it from power. Wait for 45 seconds. Reseat DIMM(s). Reconnect it to power.
4. Make sure that DSA and BIOS/uEFI are at the latest level.

**Related links**

- [IBM Support website](#)
- [Latest level of DSA](#)
- [Latest level of BMC/IMM](#)

- **201-878-000 : Standalone Memory Test Aborted**

Sparing feature must be turned OFF. Go to setup and turn the sparing feature OFF.

**Recoverable**

No

**Severity**

Warning

**Serviceable**

No

**Automatically notify support**

No

**User Response**

Complete the following steps:

1. Perform the actions mentioned one at a time and try the test after each action.
2. If the problem remains, contact your technical-service representative.
3. Turn off the system and disconnect it from power. Wait for 45 seconds. Reseat DIMM(s). Reconnect it to power.
4. Make sure that DSA and BIOS/uEFI are at the latest level.

**Related links**

- [IBM Support website](#)
- [Latest level of DSA](#)
- [Latest level of BMC/IMM](#)

**• 201-878-001 : Standalone Memory Test Aborted**

Sparing feature must be turned OFF. Go to setup and turn the sparing feature OFF.

**Recoverable**

No

**Severity**

Warning

**Serviceable**

No

**Automatically notify support**

No

**User Response**

Complete the following steps:

1. Perform the actions mentioned one at a time and try the test after each action.
2. If the problem remains, contact your technical-service representative.
3. Turn off the system and disconnect it from power. Wait for 45 seconds. Reseat DIMM(s). Reconnect it to power.
4. Make sure that DSA and BIOS/uEFI are at the latest level.

**Related links**

- [IBM Support website](#)
- [Latest level of DSA](#)
- [Latest level of BMC/IMM](#)

**• 201-878-002 : Standalone Memory Test Aborted**

Sparing feature must be turned OFF. Go to setup and turn the sparing feature OFF.

**Recoverable**

No

**Severity**

Warning

**Serviceable**

No

**Automatically notify support**

No

**User Response**

Complete the following steps:

1. Perform the actions mentioned one at a time and try the test after each action.
2. If the problem remains, contact your technical-service representative.

3. Turn off the system and disconnect it from power. Wait for 45 seconds. Reseat DIMM(s). Reconnect it to power.
4. Make sure that DSA and BIOS/uEFI are at the latest level.

**Related links**

- [IBM Support website](#)
- [Latest level of DSA](#)
- [Latest level of BMC/IMM](#)

- **201-878-003 : Standalone Memory Test Aborted**

Sparing feature must be turned OFF. Go to setup and turn the sparing feature OFF.

**Recoverable**

No

**Severity**

Warning

**Serviceable**

No

**Automatically notify support**

No

**User Response**

Complete the following steps:

1. Perform the actions mentioned one at a time and try the test after each action.
2. If the problem remains, contact your technical-service representative.
3. Turn off the system and disconnect it from power. Wait for 45 seconds. Reseat DIMM(s). Reconnect it to power.
4. Make sure that DSA and BIOS/uEFI are at the latest level.

**Related links**

- [IBM Support website](#)
- [Latest level of DSA](#)
- [Latest level of BMC/IMM](#)

- **201-885-000 : Standalone Memory Test Aborted**

Processor does not support MTRR register manipulation. Can not write to memory without cache.

**Recoverable**

No

**Severity**

Warning

**Serviceable**

No

**Automatically notify support**

No

**User Response**

Complete the following steps:

1. Perform the actions mentioned one at a time and try the test after each action.
2. If the problem remains, contact your technical-service representative.
3. Turn off the system and disconnect it from power. Wait for 45 seconds. Reseat DIMM(s). Reconnect it to power.

4. Make sure that DSA and BIOS/uEFI are at the latest level.

**Related links**

- [IBM Support website](#)
- [Latest level of DSA](#)
- [Latest level of BMC/IMM](#)

**• 201-885-001 : Standalone Memory Test Aborted**

Processor does not support MTRR register manipulation. Can not write to memory without cache.

**Recoverable**

No

**Severity**

Warning

**Serviceable**

No

**Automatically notify support**

No

**User Response**

Complete the following steps:

1. Perform the actions mentioned one at a time and try the test after each action.
2. If the problem remains, contact your technical-service representative.
3. Turn off the system and disconnect it from power. Wait for 45 seconds. Reseat DIMM(s). Reconnect it to power.
4. Make sure that DSA and BIOS/uEFI are at the latest level.

**Related links**

- [IBM Support website](#)
- [Latest level of DSA](#)
- [Latest level of BMC/IMM](#)

**• 201-885-002 : Standalone Memory Test Aborted**

Processor does not support MTRR register manipulation. Can not write to memory without cache.

**Recoverable**

No

**Severity**

Warning

**Serviceable**

No

**Automatically notify support**

No

**User Response**

Complete the following steps:

1. Perform the actions mentioned one at a time and try the test after each action.
2. If the problem remains, contact your technical-service representative.
3. Turn off the system and disconnect it from power. Wait for 45 seconds. Reseat DIMM(s). Reconnect it to power.
4. Make sure that DSA and BIOS/uEFI are at the latest level.

**Related links**

- [IBM Support website](#)
- [Latest level of DSA](#)
- [Latest level of BMC/IMM](#)

- **201-885-003 : Standalone Memory Test Aborted**

Processor does not support MTRR register manipulation. Can not write to memory without cache.

**Recoverable**

No

**Severity**

Warning

**Serviceable**

No

**Automatically notify support**

No

**User Response**

Complete the following steps:

1. Perform the actions mentioned one at a time and try the test after each action.
2. If the problem remains, contact your technical-service representative.
3. Turn off the system and disconnect it from power. Wait for 45 seconds. Reseat DIMM(s). Reconnect it to power.
4. Make sure that DSA and BIOS/uEFI are at the latest level.

**Related links**

- [IBM Support website](#)
- [Latest level of DSA](#)
- [Latest level of BMC/IMM](#)

- **201-886-000 : Standalone Memory Test Aborted**

Memory Upper limit is less than 16 Mbytes.

**Recoverable**

No

**Severity**

Warning

**Serviceable**

No

**Automatically notify support**

No

**User Response**

Complete the following steps:

1. Perform the actions mentioned one at a time and try the test after each action.
2. If the problem remains, contact your technical-service representative.
3. Turn off the system and disconnect it from power. Wait for 45 seconds. Reseat DIMM(s). Reconnect it to power.
4. Make sure that DSA and BIOS/uEFI are at the latest level.

**Related links**

- [IBM Support website](#)
- [Latest level of DSA](#)

- [Latest level of BMC/IMM](#)
- **201-886-001 : Standalone Memory Test Aborted**

Memory Upper limit is less than 16 Mbytes.

**Recoverable**

No

**Severity**

Warning

**Serviceable**

No

**Automatically notify support**

No

**User Response**

Complete the following steps:

1. Perform the actions mentioned one at a time and try the test after each action.
2. If the problem remains, contact your technical-service representative.
3. Turn off the system and disconnect it from power. Wait for 45 seconds. Reseat DIMM(s). Reconnect it to power.
4. Make sure that DSA and BIOS/uEFI are at the latest level.

**Related links**

- [IBM Support website](#)
- [Latest level of DSA](#)
- [Latest level of BMC/IMM](#)
- **201-886-002 : Standalone Memory Test Aborted**

Memory Upper limit is less than 16 Mbytes.

**Recoverable**

No

**Severity**

Warning

**Serviceable**

No

**Automatically notify support**

No

**User Response**

Complete the following steps:

1. Perform the actions mentioned one at a time and try the test after each action.
2. If the problem remains, contact your technical-service representative.
3. Turn off the system and disconnect it from power. Wait for 45 seconds. Reseat DIMM(s). Reconnect it to power.
4. Make sure that DSA and BIOS/uEFI are at the latest level.

**Related links**

- [IBM Support website](#)
- [Latest level of DSA](#)
- [Latest level of BMC/IMM](#)
- **201-886-003 : Standalone Memory Test Aborted**

Memory Upper limit is less than 16 Mbytes.

**Recoverable**

No

**Severity**

Warning

**Serviceable**

No

**Automatically notify support**

No

**User Response**

Complete the following steps:

1. Perform the actions mentioned one at a time and try the test after each action.
2. If the problem remains, contact your technical-service representative.
3. Turn off the system and disconnect it from power. Wait for 45 seconds. Reseat DIMM(s). Reconnect it to power.
4. Make sure that DSA and BIOS/uEFI are at the latest level.

**Related links**

- [IBM Support website](#)
- [Latest level of DSA](#)
- [Latest level of BMC/IMM](#)

• **201-899-000 : Standalone Memory Test Aborted**

Memory Diagnostics Test Aborted by user.

**Recoverable**

No

**Severity**

Warning

**Serviceable**

No

**Automatically notify support**

No

**Related links**

- [IBM Support website](#)
- [Latest level of DSA](#)
- [Latest level of BMC/IMM](#)

• **201-899-001 : Standalone Memory Test Aborted**

Memory Diagnostics Test Aborted by user.

**Recoverable**

No

**Severity**

Warning

**Serviceable**

No

**Automatically notify support**

No

**Related links**

- [IBM Support website](#)
- [Latest level of DSA](#)
- [Latest level of BMC/IMM](#)

- **201-899-002 : Standalone Memory Test Aborted**

Memory Diagnostics Test Aborted by user.

**Recoverable**

No

**Severity**

Warning

**Serviceable**

No

**Automatically notify support**

No

**Related links**

- [IBM Support website](#)
- [Latest level of DSA](#)
- [Latest level of BMC/IMM](#)

- **201-899-003 : Standalone Memory Test Aborted**

Memory Diagnostics Test Aborted by user.

**Recoverable**

No

**Severity**

Warning

**Serviceable**

No

**Automatically notify support**

No

**Related links**

- [IBM Support website](#)
- [Latest level of DSA](#)
- [Latest level of BMC/IMM](#)

- **201-901-000 : Standalone Memory Test Failed**

Memory Diagnostics Test Failed.

**Recoverable**

No

**Severity**

Error

**Serviceable**

Yes

**Automatically notify support**

No

**User Response**

Complete the following steps:



1. Perform the actions mentioned one at a time and try the test after each action.
2. If the problem remains, contact your technical-service representative.
3. Turn off the system and disconnect it from power. Wait for 45 seconds. Reseat DIMM(s). Reconnect it to power.
4. Make sure that DSA and BIOS/uEFI are at the latest level.
5. Replace any DIMMS(s) mentioned in error, one by one.
6. Make sure that all DIMMs are enabled in the Configuration/Setup Utility program.
7. If failure remains, refer to "Troubleshooting by symptom" in the system "Installation and Service Guide" for the next corrective action.

**Related links**

- [IBM Support website](#)
- [Latest level of DSA](#)
- [Latest level of BMC/IMM](#)

- **201-901-001 : Standalone Memory Test Failed**

Memory Diagnostics Test Failed.

**Recoverable**

No

**Severity**

Error

**Serviceable**

Yes

**Automatically notify support**

No

**User Response**

Complete the following steps:

1. Perform the actions mentioned one at a time and try the test after each action.
2. If the problem remains, contact your technical-service representative.
3. Turn off the system and disconnect it from power. Wait for 45 seconds. Reseat DIMM(s). Reconnect it to power.
4. Make sure that DSA and BIOS/uEFI are at the latest level.
5. Replace any DIMMS(s) mentioned in error, one by one.
6. Make sure that all DIMMs are enabled in the Configuration/Setup Utility program.
7. If failure remains, refer to "Troubleshooting by symptom" in the system "Installation and Service Guide" for the next corrective action.

**Related links**

- [IBM Support website](#)
- [Latest level of DSA](#)
- [Latest level of BMC/IMM](#)

- **201-901-002 : Standalone Memory Test Failed**

Memory Diagnostics Test Failed.

**Recoverable**

No

**Severity**

Error

**Serviceable**

Yes

**Automatically notify support**

No

**User Response**

Complete the following steps:

1. Perform the actions mentioned one at a time and try the test after each action.
2. If the problem remains, contact your technical-service representative.
3. Turn off the system and disconnect it from power. Wait for 45 seconds. Reseat DIMM(s). Reconnect it to power.
4. Make sure that DSA and BIOS/uEFI are at the latest level.
5. Replace any DIMMS(s) mentioned in error, one by one.
6. Make sure that all DIMMs are enabled in the Configuration/Setup Utility program.
7. If failure remains, refer to "Troubleshooting by symptom" in the system "Installation and Service Guide" for the next corrective action.

**Related links**

- [IBM Support website](#)
- [Latest level of DSA](#)
- [Latest level of BMC/IMM](#)

- **201-901-003 : Standalone Memory Test Failed**

Memory Diagnostics Test Failed.

**Recoverable**

No

**Severity**

Error

**Serviceable**

Yes

**Automatically notify support**

No

**User Response**

Complete the following steps:

1. Perform the actions mentioned one at a time and try the test after each action.
2. If the problem remains, contact your technical-service representative.
3. Turn off the system and disconnect it from power. Wait for 45 seconds. Reseat DIMM(s). Reconnect it to power.
4. Make sure that DSA and BIOS/uEFI are at the latest level.
5. Replace any DIMMS(s) mentioned in error, one by one.
6. Make sure that all DIMMs are enabled in the Configuration/Setup Utility program.
7. If failure remains, refer to "Troubleshooting by symptom" in the system "Installation and Service Guide" for the next corrective action.

**Related links**

- [IBM Support website](#)
- [Latest level of DSA](#)
- [Latest level of BMC/IMM](#)

---

## DSA memory stress test results

The following messages can result when you run the memory stress test.

### Test results for the DSA memory stress test

The following messages can result when you run the DSA memory stress test.

- **202-000-000 : MemStr Test Passed**

Test Passed.

**Recoverable**

No

**Severity**

Event

**Serviceable**

No

**Automatically notify support**

No

**Related links**

- [IBM Support website](#)
- [Latest level of DSA](#)
- [Latest level of BMC/IMM](#)

- **202-801-000 : MemStr Test Aborted**

Internal program error.

**Recoverable**

No

**Severity**

Warning

**Serviceable**

Yes

**Automatically notify support**

No

**User Response**

Complete the following steps:

1. Turn off and restart the system.
2. Make sure that the DSA Diagnostic code is at the latest level.
3. Run the test again.
4. If the system has stopped responding, turn off and restart the system.
5. Check the system firmware level and upgrade if necessary.
6. Run the memory diagnostic to identify the specific failing DIMM.
7. If the failure remains, refer to "Troubleshooting by symptom" in the system "Installation and Service Guide" for the next corrective action.

**Related links**

- [IBM Support website](#)
- [Latest level of DSA](#)

– [Latest level of BMC/IMM](#)

- **202-802-000 : MemStr Test Aborted**

Memory size is insufficient to run the test. At least 1 GB is required.

**Recoverable**

No

**Severity**

Warning

**Serviceable**

Yes

**Automatically notify support**

No

**Related links**

- [IBM Support website](#)
- [Latest level of DSA](#)
- [Latest level of BMC/IMM](#)

- **202-803-000 : MemStr Test Aborted**

User pressed Ctrl-C.

**Recoverable**

No

**Severity**

Warning

**Serviceable**

Yes

**Automatically notify support**

No

**Related links**

- [IBM Support website](#)
- [Latest level of DSA](#)
- [Latest level of BMC/IMM](#)

- **202-901-000 : MemStr Test Failed**

Test Failed.

**Recoverable**

No

**Severity**

Error

**Serviceable**

Yes

**Automatically notify support**

No

**User Response**

Complete the following steps:

1. Execute the standard DSA memory diagnostics to validate all memory.
2. Make sure that the DSA Diagnostic code is at the latest level.
3. Turn off the system and disconnect it from power.

4. Reseat the memory cards and DIMMs.
5. Reconnect the system to power and turn the system on.
6. Run the test again.
7. Execute the standard DSA memory diagnostics to validate all memory.
8. If the failure remains, refer to "Troubleshooting by symptom" in the system "Installation and Service Guide" for the next corrective action.

**Related links**

- [IBM Support website](#)
  - [Latest level of DSA](#)
  - [Latest level of BMC/IMM](#)
- **202-902-000 : MemStr Test Failed**  
Memory size is insufficient to run the test.

**Recoverable**

No

**Severity**

Error

**Serviceable**

Yes

**Automatically notify support**

No

**User Response**

Complete the following steps:

1. Ensure that all memory is enabled by checking the "Available System Memory" in the "Resource Utilization" section of the DSA Diagnostic Event log.
2. If necessary, access the Configuration/Setup Utility program by pressing F1 during system boot and enable all memory.
3. Make sure that the DSA Diagnostic code is at the latest level.
4. Run the test again.
5. Execute the standard DSA memory diagnostics to validate all memory.
6. If the failure remains, refer to "Troubleshooting by symptom" in the system "Installation and Service Guide" for the next corrective action.

**Related links**

- [IBM Support website](#)
- [Latest level of DSA](#)
- [Latest level of BMC/IMM](#)

---

## DSA Nvidia GPU test results

The following messages can result when you run the Nvidia GPU test.

### Test results for the DSA Nvidia GPU test

The following messages can result when you run the DSA Nvidia GPU test.

- **409-000-000 : NVIDIA User Diagnostic Test Passed**  
NVIDIA User Diagnostic test passed.

**Recoverable**

No

**Severity**

Event

**Serviceable**

No

**Automatically notify support**

No

**Related links**

- [IBM Support website](#)
- [Latest level of DSA](#)
- [Latest level of BMC/IMM](#)

- **409-003-000 : Nvidia::DiagnosticServiceProvider::Bandwidth Test Passed**

Nvidia GPU Bandwidth test passed.

**Recoverable**

No

**Severity**

Event

**Serviceable**

No

**Automatically notify support**

No

**Related links**

- [IBM Support website](#)
- [Latest level of DSA](#)
- [Latest level of BMC/IMM](#)

- **409-004-000 : Nvidia::DiagnosticServiceProvider::Query Test Passed**

Nvidia GPU Query test passed.

**Recoverable**

No

**Severity**

Event

**Serviceable**

No

**Automatically notify support**

No

**Related links**

- [IBM Support website](#)
- [Latest level of DSA](#)
- [Latest level of BMC/IMM](#)

- **409-005-000 : Nvidia::DiagnosticServiceProvider::Matrix Test Passed**

Nvidia GPU Matrix test passed.

**Recoverable**

No

**Severity**

Event

**Serviceable**

No

**Automatically notify support**

No

**Related links**

- [IBM Support website](#)
- [Latest level of DSA](#)
- [Latest level of BMC/IMM](#)

- **409-006-000 : Nvidia::DiagnosticServiceProvider::Binomial Test Passed**

Nvidia GPU Binomial test passed.

**Recoverable**

No

**Severity**

Event

**Serviceable**

No

**Automatically notify support**

No

**Related links**

- [IBM Support website](#)
- [Latest level of DSA](#)
- [Latest level of BMC/IMM](#)

- **409-800-000 : NVIDIA User Diagnostic Test Aborted**

NVIDIA User Diagnostic test was canceled.

**Recoverable**

No

**Severity**

Event

**Serviceable**

No

**Automatically notify support**

No

**Related links**

- [IBM Support website](#)
- [Latest level of DSA](#)
- [Latest level of BMC/IMM](#)

- **409-803-000 : Nvidia::DiagnosticServiceProvider::Bandwidth Test Aborted**

Nvidia GPU Bandwidth test was canceled.

**Recoverable**

No

**Severity**

Warning

**Serviceable**

No

**Automatically notify support**

No

**Related links**

- [IBM Support website](#)
- [Latest level of DSA](#)
- [Latest level of BMC/IMM](#)

- **409-804-000 : Nvidia::DiagnosticServiceProvider::Query Test Aborted**

Nvidia GPU Query test was canceled.

**Recoverable**

No

**Severity**

Warning

**Serviceable**

No

**Automatically notify support**

No

**Related links**

- [IBM Support website](#)
- [Latest level of DSA](#)
- [Latest level of BMC/IMM](#)

- **409-805-000 : Nvidia::DiagnosticServiceProvider::Matrix Test Aborted**

Nvidia GPU Matrix test was canceled.

**Recoverable**

No

**Severity**

Warning

**Serviceable**

No

**Automatically notify support**

No

**Related links**

- [IBM Support website](#)
- [Latest level of DSA](#)
- [Latest level of BMC/IMM](#)

- **409-806-000 : Nvidia::DiagnosticServiceProvider::Binomial Test Aborted**

Nvidia GPU Binomial test was canceled.

**Recoverable**

No

**Severity**

Warning

**Serviceable**

No



**Automatically notify support**

No

**Related links**

- [IBM Support website](#)
- [Latest level of DSA](#)
- [Latest level of BMC/IMM](#)

- **409-900-000 : NVIDIA User Diagnostic Test Failed**

NVIDIA User Diagnostic Test Failed.

**Recoverable**

No

**Severity**

Event

**Serviceable**

Yes

**Automatically notify support**

No

**User Response**

Complete the following steps:

1. Verify that the GPU is seated in the PCIe slot correctly by reseating the GPU. Then power cycle the system.
2. Verify that the power connectors to the GPU are connected firmly. Then power cycle the system.
3. Run nvidia-smi -q In some cases this will report a poorly connected power cable.
4. Rerun the diagnostics, using the same GPU, on system that is known to be working. A variety of system issues can cause diagnostic failure.
5. If the problem remains, contact your IBM technical-support representative.

**Related links**

- [IBM Support website](#)
- [Latest level of DSA](#)
- [Latest level of BMC/IMM](#)

- **409-903-000 : Nvidia::DiagnosticServiceProvider::Bandwidth Test Failed**

Nvidia GPU Bandwidth Test Failed.

**Recoverable**

No

**Severity**

Error

**Serviceable**

Yes

**Automatically notify support**

No

**User Response**

Complete the following steps:

1. Verify that the GPU is seated in the PCIe slot correctly by reseating the GPU. Then power cycle the system.
2. Verify that the power connectors to the GPU are connected firmly. Then power cycle the system.

3. Run `nvidia-smi -q` In some cases this will report a poorly connected power cable.
4. Rerun the diagnostics, using the same GPU, on system that is known to be working. A variety of system issues can cause diagnostic failure.
5. If the problem remains, contact your IBM technical-support representative.

**Related links**

- [IBM Support website](#)
- [Latest level of DSA](#)
- [Latest level of BMC/IMM](#)

- **409-904-000 : Nvidia::DiagnosticServiceProvider::Query Test Failed**

Nvidia GPU Query Test Failed.

**Recoverable**

No

**Severity**

Error

**Serviceable**

Yes

**Automatically notify support**

No

**User Response**

Complete the following steps:

1. Verify that the GPU is seated in the PCIe slot correctly by reseating the GPU. Then power cycle the system.
2. Verify that the power connectors to the GPU are connected firmly. Then power cycle the system.
3. Run `nvidia-smi -q` In some cases this will report a poorly connected power cable.
4. Rerun the diagnostics, using the same GPU, on system that is known to be working. A variety of system issues can cause diagnostic failure.
5. If the problem remains, contact your IBM technical-support representative.

**Related links**

- [IBM Support website](#)
- [Latest level of DSA](#)
- [Latest level of BMC/IMM](#)

- **409-905-000 : Nvidia::DiagnosticServiceProvider::Matrix Test Failed**

Nvidia GPU Matrix Test Failed.

**Recoverable**

No

**Severity**

Error

**Serviceable**

Yes

**Automatically notify support**

No

**User Response**

Complete the following steps:

1. Verify that the GPU is seated in the PCIe slot correctly by reseating the GPU. Then power cycle the system.
2. Verify that the power connectors to the GPU are connected firmly. Then power cycle the system.
3. Run `nvidia-smi -q` In some cases this will report a poorly connected power cable.
4. Rerun the diagnostics, using the same GPU, on system that is known to be working. A variety of system issues can cause diagnostic failure.
5. If the problem remains, contact your IBM technical-support representative.

**Related links**

- [IBM Support website](#)
  - [Latest level of DSA](#)
  - [Latest level of BMC/IMM](#)
- **409-906-000 : Nvidia::DiagnosticServiceProvider::Binomial Test Failed**  
Nvidia GPU Binomial Test Failed.

**Recoverable**

No

**Severity**

Error

**Serviceable**

Yes

**Automatically notify support**

No

**User Response**

Complete the following steps:

1. Verify that the GPU is seated in the PCIe slot correctly by reseating the GPU. Then power cycle the system.
2. Verify that the power connectors to the GPU are connected firmly. Then power cycle the system.
3. Run `nvidia-smi -q` In some cases this will report a poorly connected power cable.
4. Rerun the diagnostics, using the same GPU, on system that is known to be working. A variety of system issues can cause diagnostic failure.
5. If the problem remains, contact your IBM technical-support representative.

**Related links**

- [IBM Support website](#)
- [Latest level of DSA](#)
- [Latest level of BMC/IMM](#)

---

## DSA optical drive test results

The following messages can result when you run the optical drive test.

### Test results for the DSA optical drive test

The following messages can result when you run the DSA optical drive test.

- **215-000-000 : Optical Drive Test Passed**  
Optical Drive Test Passed.

**Recoverable**

No

**Severity**

Event

**Serviceable**

No

**Automatically notify support**

No

**Related links**

- [IBM Support website](#)
- [Latest level of DSA](#)
- [Latest level of BMC/IMM](#)

• **215-801-000 : Optical Drive Test Aborted**

Optical Drive Test Aborted. Unable to communicate with driver.

**Recoverable**

No

**Severity**

Warning

**Serviceable**

Yes

**Automatically notify support**

No

**User Response**

Complete the following steps:

1. Make sure that the DSA Diagnostic code is at the latest level.
2. Run the test again.
3. Check the drive cabling for loose or broken connections at both ends or damage to the cable. Replace the cable if damage is present.
4. Run the test again.
5. Check system firmware level and upgrade if necessary. The installed firmware level can be found in the DSA Diagnostic Event Log within the Firmware/VPD section for this component.
6. Run the test again.

**Related links**

- [IBM Support website](#)
- [Latest level of DSA](#)
- [Latest level of BMC/IMM](#)

• **215-802-000 : Optical Drive Test Aborted**

Optical Drive Test Aborted. A read error was encountered.

**Recoverable**

No

**Severity**

Warning

**Serviceable**

Yes

**Automatically notify support**

No

**User Response**

Complete the following steps:

1. Insert a new CD or DVD into the drive and wait for 15 seconds for the media to be recognized. Rerun the test.
2. Check the drive cabling for loose or broken connections at both ends or damage to the cable. Replace the cable if damage is present.
3. Run the test again.
4. If failure remains, refer to "Troubleshooting by symptom" in the system "Installation and Service Guide" for the next corrective action.

**Related links**

- [IBM Support website](#)
- [Latest level of DSA](#)
- [Latest level of BMC/IMM](#)

• **215-803-000 : Optical Drive Test Failed**

Optical Drive Test Failed. Disk may be in use by the operating system.

**Recoverable**

No

**Severity**

Error

**Serviceable**

Yes

**Automatically notify support**

No

**User Response**

Complete the following steps:

1. Wait for the system activity to cease
2. Run the test again
3. Turn off and restart the system.
4. Run the test again.

**Related links**

- [IBM Support website](#)
- [Latest level of DSA](#)
- [Latest level of BMC/IMM](#)

• **215-804-000 : Optical Drive Test Aborted**

Optical Drive Test Aborted. The media tray is open.

**Recoverable**

No

**Severity**

Warning

**Serviceable**

Yes

**Automatically notify support**

No

### User Response

Complete the following steps:

1. Close the media tray and wait for 15 seconds for the media to be recognized. Run the test again.
2. Insert a new CD or DVD into the drive and wait for 15 seconds for the media to be recognized. Rerun the test.
3. Check the drive cabling for loose or broken connections at both ends or damage to the cable. Replace the cable if damage is present.
4. Run the test again.
5. If failure remains, refer to "Troubleshooting by symptom" in the system "Installation and Service Guide" for the next corrective action.

### Related links

- [IBM Support website](#)
- [Latest level of DSA](#)
- [Latest level of BMC/IMM](#)

#### • 215-901-000 : Optical Drive Test Aborted

Optical Drive Test Aborted. Drive media is not detected.

### Recoverable

No

### Severity

Warning

### Serviceable

Yes

### Automatically notify support

No

### User Response

Complete the following steps:

1. Insert a new CD or DVD into the drive and wait for 15 seconds for the media to be recognized. Rerun the test.
2. Check the drive cabling for loose or broken connections at both ends or damage to the cable. Replace the cable if damage is present.
3. Run the test again.
4. If failure remains, refer to "Troubleshooting by symptom" in the system "Installation and Service Guide" for the next corrective action.

### Related links

- [IBM Support website](#)
- [Latest level of DSA](#)
- [Latest level of BMC/IMM](#)

#### • 215-902-000 : Optical Drive Test Failed

Optical Drive Test Failed. Read miscompare.

### Recoverable

No

### Severity

Error

### Serviceable

Yes

**Automatically notify support**

No

**User Response**

Complete the following steps:

1. Insert a new CD or DVD into the drive and wait for 15 seconds for the media to be recognized. Rerun the test.
2. Check the drive cabling for loose or broken connections at both ends or damage to the cable. Replace the cable if damage is present.
3. Run the test again.
4. If failure remains, refer to "Troubleshooting by symptom" in the system "Installation and Service Guide" for the next corrective action.

**Related links**

- [IBM Support website](#)
  - [Latest level of DSA](#)
  - [Latest level of BMC/IMM](#)
- **215-903-000 : Optical Drive Test Aborted**

Optical Drive Test Aborted. Could not access the device.

**Recoverable**

No

**Severity**

Warning

**Serviceable**

Yes

**Automatically notify support**

No

**User Response**

Complete the following steps:

1. Insert a new CD or DVD into the drive and wait for 15 seconds for the media to be recognized. Rerun the test.
2. Check the drive cabling for loose or broken connections at both ends or damage to the cable. Replace the cable if damage is present.
3. Run the test again.
4. Check system firmware level and upgrade if necessary. The installed firmware level can be found in the DSA Diagnostic Event Log within the Firmware/VPD section for this component.
5. Run the test again.
6. If failure remains, refer to "Troubleshooting by symptom" in the system "Installation and Service Guide" for the next corrective action.

**Related links**

- [IBM Support website](#)
- [Latest level of DSA](#)
- [Latest level of BMC/IMM](#)

---

**DSA system management test results**

The following messages can result when you run the system management test.

## Test results for the DSA system management test

The following messages can result when you run the DSA system management test.

- **166-000-001 : IMM I2C Test Passed**

IMM I2C Test Passed.

**Recoverable**

No

**Severity**

Event

**Serviceable**

No

**Automatically notify support**

No

**Related links**

- [IBM Support website](#)
- [Latest level of DSA](#)
- [Latest level of BMC/IMM](#)

- **166-801-001 : IMM I2C Test Aborted**

IMM returned incorrect response length.

**Recoverable**

No

**Severity**

Warning

**Serviceable**

Yes

**Automatically notify support**

No

**User Response**

Perform the actions mentioned one at a time and try the test after each action:

1. Turn off the system and disconnect it from power. Wait for 45 seconds. Reconnect it to power.
2. Make sure that DSA and BMC/IMM are at the latest level.

**Related links**

- [IBM Support website](#)
- [Latest level of DSA](#)
- [Latest level of BMC/IMM](#)

- **166-802-001 : IMM I2C Test Aborted**

Test cannot be completed for unknown reason.

**Recoverable**

No

**Severity**

Warning

**Serviceable**

Yes

**Automatically notify support**



No

**User Response**

Perform the actions mentioned one at a time and try the test after each action:

1. Turn off the system and disconnect it from power. Wait for 45 seconds. Reconnect it to power.
2. Make sure that DSA and BMC/IMM are at the latest level.

**Related links**

- [IBM Support website](#)
- [Latest level of DSA](#)
- [Latest level of BMC/IMM](#)

• **166-803-001 : IMM I2C Test Aborted**

Node Busy. Try later.

**Recoverable**

No

**Severity**

Warning

**Serviceable**

Yes

**Automatically notify support**

No

**User Response**

Perform the actions mentioned one at a time and try the test after each action:

1. Turn off the system and disconnect it from power. Wait for 45 seconds. Reconnect it to power.
2. Make sure that DSA and BMC/IMM are at the latest level.

**Related links**

- [IBM Support website](#)
- [Latest level of DSA](#)
- [Latest level of BMC/IMM](#)

• **166-804-001 : IMM I2C Test Aborted**

Invalid Command.

**Recoverable**

No

**Severity**

Warning

**Serviceable**

Yes

**Automatically notify support**

No

**User Response**

Perform the actions mentioned one at a time and try the test after each action:

1. Turn off the system and disconnect it from power. Wait for 45 seconds. Reconnect it to power.
2. Make sure that DSA and BMC/IMM are at the latest level.

**Related links**

- [IBM Support website](#)
- [Latest level of DSA](#)

- [Latest level of BMC/IMM](#)
- **166-805-001 : IMM I2C Test Aborted**

Invalid Command for given LUN.

**Recoverable**

No

**Severity**

Warning

**Serviceable**

Yes

**Automatically notify support**

No

**User Response**

Perform the actions mentioned one at a time and try the test after each action:

1. Turn off the system and disconnect it from power. Wait for 45 seconds. Reconnect it to power.
2. Make sure that DSA and BMC/IMM are at the latest level.

**Related links**

- [IBM Support website](#)
- [Latest level of DSA](#)
- [Latest level of BMC/IMM](#)

- **166-806-001 : IMM I2C Test Aborted**

Timeout while processing command.

**Recoverable**

No

**Severity**

Warning

**Serviceable**

Yes

**Automatically notify support**

No

**User Response**

Perform the actions mentioned one at a time and try the test after each action:

1. Turn off the system and disconnect it from power. Wait for 45 seconds. Reconnect it to power.
2. Make sure that DSA and BMC/IMM are at the latest level.

**Related links**

- [IBM Support website](#)
- [Latest level of DSA](#)
- [Latest level of BMC/IMM](#)

- **166-807-001 : IMM I2C Test Aborted**

Out of space.

**Recoverable**

No

**Severity**

Warning

**Serviceable**

Yes

**Automatically notify support**

No

**User Response**

Perform the actions mentioned one at a time and try the test after each action:

1. Turn off the system and disconnect it from power. Wait for 45 seconds. Reconnect it to power.
2. Make sure that DSA and BMC/IMM are at the latest level.

**Related links**

- [IBM Support website](#)
- [Latest level of DSA](#)
- [Latest level of BMC/IMM](#)

• **166-808-001 : IMM I2C Test Aborted**

Reservation Canceled or Invalid Reservation ID.

**Recoverable**

No

**Severity**

Warning

**Serviceable**

Yes

**Automatically notify support**

No

**User Response**

Perform the actions mentioned one at a time and try the test after each action:

1. Turn off the system and disconnect it from power. Wait for 45 seconds. Reconnect it to power.
2. Make sure that DSA and BMC/IMM are at the latest level.

**Related links**

- [IBM Support website](#)
- [Latest level of DSA](#)
- [Latest level of BMC/IMM](#)

• **166-809-001 : IMM I2C Test Aborted**

Request data truncated.

**Recoverable**

No

**Severity**

Warning

**Serviceable**

Yes

**Automatically notify support**

No

**User Response**

Perform the actions mentioned one at a time and try the test after each action:

1. Turn off the system and disconnect it from power. Wait for 45 seconds. Reconnect it to power.
2. Make sure that DSA and BMC/IMM are at the latest level.

**Related links**

- [IBM Support website](#)
- [Latest level of DSA](#)
- [Latest level of BMC/IMM](#)

- **166-810-001 : IMM I2C Test Aborted**

Request data length invalid.

**Recoverable**

No

**Severity**

Warning

**Serviceable**

Yes

**Automatically notify support**

No

**User Response**

Perform the actions mentioned one at a time and try the test after each action:

1. Turn off the system and disconnect it from power. Wait for 45 seconds. Reconnect it to power.
2. Make sure that DSA and BMC/IMM are at the latest level.

**Related links**

- [IBM Support website](#)
- [Latest level of DSA](#)
- [Latest level of BMC/IMM](#)

- **166-811-001 : IMM I2C Test Aborted**

Request data field length limit exceeded.

**Recoverable**

No

**Severity**

Warning

**Serviceable**

Yes

**Automatically notify support**

No

**User Response**

Perform the actions mentioned one at a time and try the test after each action:

1. Turn off the system and disconnect it from power. Wait for 45 seconds. Reconnect it to power.
2. Make sure that DSA and BMC/IMM are at the latest level.

**Related links**

- [IBM Support website](#)
- [Latest level of DSA](#)
- [Latest level of BMC/IMM](#)

- **166-812-001 : IMM I2C Test Aborted**

Parameter out of range.

**Recoverable**

No

**Severity**

Warning

**Serviceable**

Yes

**Automatically notify support**

No

**User Response**

Perform the actions mentioned one at a time and try the test after each action:

1. Turn off the system and disconnect it from power. Wait for 45 seconds. Reconnect it to power.
2. Make sure that DSA and BMC/IMM are at the latest level.

**Related links**

- [IBM Support website](#)
- [Latest level of DSA](#)
- [Latest level of BMC/IMM](#)

• **166-813-001 : IMM I2C Test Aborted**

Cannot return number of requested data bytes.

**Recoverable**

No

**Severity**

Warning

**Serviceable**

Yes

**Automatically notify support**

No

**User Response**

Perform the actions mentioned one at a time and try the test after each action:

1. Turn off the system and disconnect it from power. Wait for 45 seconds. Reconnect it to power.
2. Make sure that DSA and BMC/IMM are at the latest level.

**Related links**

- [IBM Support website](#)
- [Latest level of DSA](#)
- [Latest level of BMC/IMM](#)

• **166-814-001 : IMM I2C Test Aborted**

Requested Sensor, data, or record not present.

**Recoverable**

No

**Severity**

Warning

**Serviceable**

Yes

**Automatically notify support**

No

**User Response**

Perform the actions mentioned one at a time and try the test after each action:

1. Turn off the system and disconnect it from power. Wait for 45 seconds. Reconnect it to power.

2. Make sure that DSA and BMC/IMM are at the latest level.

**Related links**

- [IBM Support website](#)
- [Latest level of DSA](#)
- [Latest level of BMC/IMM](#)

- **166-815-001 : IMM I2C Test Aborted**

Invalid data field in Request.

**Recoverable**

No

**Severity**

Warning

**Serviceable**

Yes

**Automatically notify support**

No

**User Response**

Perform the actions mentioned one at a time and try the test after each action:

1. Turn off the system and disconnect it from power. Wait for 45 seconds. Reconnect it to power.
2. Make sure that DSA and BMC/IMM are at the latest level.

**Related links**

- [IBM Support website](#)
- [Latest level of DSA](#)
- [Latest level of BMC/IMM](#)

- **166-816-001 : IMM I2C Test Aborted**

Command illegal for specified sensor or record type.

**Recoverable**

No

**Severity**

Warning

**Serviceable**

Yes

**Automatically notify support**

No

**User Response**

Perform the actions mentioned one at a time and try the test after each action:

1. Turn off the system and disconnect it from power. Wait for 45 seconds. Reconnect it to power.
2. Make sure that DSA and BMC/IMM are at the latest level.

**Related links**

- [IBM Support website](#)
- [Latest level of DSA](#)
- [Latest level of BMC/IMM](#)

- **166-817-001 : IMM I2C Test Aborted**

Command response could not be provided.

**Recoverable**

No

**Severity**

Warning

**Serviceable**

Yes

**Automatically notify support**

No

**User Response**

Perform the actions mentioned one at a time and try the test after each action:

1. Turn off the system and disconnect it from power. Wait for 45 seconds. Reconnect it to power.
2. Make sure that DSA and BMC/IMM are at the latest level.

**Related links**

- [IBM Support website](#)
- [Latest level of DSA](#)
- [Latest level of BMC/IMM](#)

• **166-818-001 : IMM I2C Test Aborted**

Cannot execute duplicated request.

**Recoverable**

No

**Severity**

Warning

**Serviceable**

Yes

**Automatically notify support**

No

**User Response**

Perform the actions mentioned one at a time and try the test after each action:

1. Turn off the system and disconnect it from power. Wait for 45 seconds. Reconnect it to power.
2. Make sure that DSA and BMC/IMM are at the latest level.

**Related links**

- [IBM Support website](#)
- [Latest level of DSA](#)
- [Latest level of BMC/IMM](#)

• **166-819-001 : IMM I2C Test Aborted**

Command response could not be provided. SDR Repository in?update mode.

**Recoverable**

No

**Severity**

Warning

**Serviceable**

Yes

**Automatically notify support**

No

**User Response**

Perform the actions mentioned one at a time and try the test after each action:

1. Turn off the system and disconnect it from power. Wait for 45 seconds. Reconnect it to power.
2. Make sure that DSA and BMC/IMM are at the latest level.

**Related links**

- [IBM Support website](#)
- [Latest level of DSA](#)
- [Latest level of BMC/IMM](#)

• **166-820-001 : IMM I2C Test Aborted**

Command response could not be provided. Device in firmware update mode.

**Recoverable**

No

**Severity**

Warning

**Serviceable**

Yes

**Automatically notify support**

No

**User Response**

Perform the actions mentioned one at a time and try the test after each action:

1. Turn off the system and disconnect it from power. Wait for 45 seconds. Reconnect it to power.
2. Make sure that DSA and BMC/IMM are at the latest level.

**Related links**

- [IBM Support website](#)
- [Latest level of DSA](#)
- [Latest level of BMC/IMM](#)

• **166-821-001 : IMM I2C Test Aborted**

Command response could not be provided. BMC initialization in progress.

**Recoverable**

No

**Severity**

Warning

**Serviceable**

Yes

**Automatically notify support**

No

**User Response**

Perform the actions mentioned one at a time and try the test after each action:

1. Turn off the system and disconnect it from power. Wait for 45 seconds. Reconnect it to power.
2. Make sure that DSA and BMC/IMM are at the latest level.

**Related links**

- [IBM Support website](#)
- [Latest level of DSA](#)
- [Latest level of BMC/IMM](#)

• **166-822-001 : IMM I2C Test Aborted**



Destination unavailable.

**Recoverable**

No

**Severity**

Warning

**Serviceable**

Yes

**Automatically notify support**

No

**User Response**

Perform the actions mentioned one at a time and try the test after each action:

1. Turn off the system and disconnect it from power. Wait for 45 seconds. Reconnect it to power.
2. Make sure that DSA and BMC/IMM are at the latest level.

**Related links**

- [IBM Support website](#)
- [Latest level of DSA](#)
- [Latest level of BMC/IMM](#)

• **166-823-001 : IMM I2C Test Aborted**

Cannot execute command. Insufficient privilege level.

**Recoverable**

No

**Severity**

Warning

**Serviceable**

Yes

**Automatically notify support**

No

**User Response**

Perform the actions mentioned one at a time and try the test after each action:

1. Turn off the system and disconnect it from power. Wait for 45 seconds. Reconnect it to power.
2. Make sure that DSA and BMC/IMM are at the latest level.

**Related links**

- [IBM Support website](#)
- [Latest level of DSA](#)
- [Latest level of BMC/IMM](#)

• **166-824-001 : IMM I2C Test Aborted**

Cannot execute command.

**Recoverable**

No

**Severity**

Warning

**Serviceable**

Yes

**Automatically notify support**

No

**User Response**

Perform the actions mentioned one at a time and try the test after each action:

1. Turn off the system and disconnect it from power. Wait for 45 seconds. Reconnect it to power.
2. Make sure that DSA and BMC/IMM are at the latest level.

**Related links**

- [IBM Support website](#)
- [Latest level of DSA](#)
- [Latest level of BMC/IMM](#)

**• 166-904-001 : IMM I2C Test Failed**

IMM Indicates failure in PCA9557--I2C I/O Expander bus (BUS 3).

**Recoverable**

No

**Severity**

Error

**Serviceable**

Yes

**Automatically notify support**

No

**User Response**

Perform the actions mentioned one at a time and try the test after each action:

1. Turn off the system and disconnect it from power. Wait for 45 seconds. Reconnect it to power.
2. Make sure that DSA and BMC/IMM are at the latest level.
3. Run the test again.
4. If failure remains, refer to "Troubleshooting by symptom" in the system "Installation and Service Guide" for the next corrective action.

**Related links**

- [IBM Support website](#)
- [Latest level of DSA](#)
- [Latest level of BMC/IMM](#)

**• 166-907-001 : IMM I2C Test Failed**

IMM Indicates failure in PCA9545--4-Channel I2C Switch bus (BUS 6).

**Recoverable**

No

**Severity**

Error

**Serviceable**

Yes

**Automatically notify support**

No

**User Response**

Perform the actions mentioned one at a time and try the test after each action:

1. Turn off the system and disconnect it from power. Wait for 45 seconds. Reconnect it to power.

2. Make sure that DSA and BMC/IMM are at the latest level.
3. Run the test again.
4. If failure remains, refer to "Troubleshooting by symptom" in the system "Installation and Service Guide" for the next corrective action.

**Related links**

- [IBM Support website](#)
- [Latest level of DSA](#)
- [Latest level of BMC/IMM](#)

- **166-908-001 : IMM I2C Test Failed**

IMM Indicates failure in PCA9545 --failure in 4-Channel I2C Switch bus (BUS 7).

**Recoverable**

No

**Severity**

Error

**Serviceable**

Yes

**Automatically notify support**

No

**User Response**

Perform the actions mentioned one at a time and try the test after each action:

1. Turn off the system and disconnect it from power. Wait for 45 seconds. Reconnect it to power.
2. Make sure that DSA and BMC/IMM are at the latest level.
3. Run the test again.
4. If failure remains, refer to "Troubleshooting by symptom" in the system "Installation and Service Guide" for the next corrective action.

**Related links**

- [IBM Support website](#)
- [Latest level of DSA](#)
- [Latest level of BMC/IMM](#)

---

## DSA tape drive test results

The following messages can result when you run the tape drive test.

### Test results for the DSA tape drive test

The following messages can result when you run the DSA tape drive test.

- **264-000-000 : Tape Test Passed**

Tape Test Passed.

**Recoverable**

No

**Severity**

Event

**Serviceable**

No

**Automatically notify support**

No

**Related links**

- [IBM Support website](#)
- [Latest level of DSA](#)
- [Latest level of BMC/IMM](#)

**• 264-901-000 : Tape Test Failed**

An error was found in the tape alert log.

**Recoverable**

No

**Severity**

Error

**Serviceable**

Yes

**Automatically notify support**

No

**User Response**

Complete the following steps:

1. Clean the tape drive using the appropriate cleaning media and install new media.
2. Run the test again.
3. Clear the error log.
4. Run the test again.
5. Make sure that the drive firmware is at the latest level.
6. Rerun the test after upgrading to the latest firmware level.
7. If the failure remains, refer to "Troubleshooting by symptom" in the system "Installation and Service Guide" for the next corrective action.

**Related links**

- [IBM Support website](#)
- [Latest level of DSA](#)
- [Latest level of BMC/IMM](#)

**• 264-902-000 : Tape Test Failed**

Tape Test Failed. Media is not detected.

**Recoverable**

No

**Severity**

Error

**Serviceable**

Yes

**Automatically notify support**

No

**User Response**

Complete the following steps:

1. Clean the tape drive using the appropriate cleaning media and install new media.
2. Run the test again.

3. Make sure that the drive firmware is at the latest level.
4. Rerun the test after upgrading to the latest firmware level.
5. If the failure remains, refer to "Troubleshooting by symptom" in the system "Installation and Service Guide" for the next corrective action.

**Related links**

- [IBM Support website](#)
- [Latest level of DSA](#)
- [Latest level of BMC/IMM](#)

**• 264-903-000 : Tape Test Failed**

Tape Test Failed. Media is not detected.

**Recoverable**

No

**Severity**

Error

**Serviceable**

Yes

**Automatically notify support**

No

**User Response**

Complete the following steps:

1. Clean the tape drive using the appropriate cleaning media and install new media.
2. Run the test again.
3. Make sure that the drive firmware is at the latest level.
4. Rerun the test after upgrading to the latest firmware level.
5. If the failure remains, refer to "Troubleshooting by symptom" in the system "Installation and Service Guide" for the next corrective action.

**Related links**

- [IBM Support website](#)
- [Latest level of DSA](#)
- [Latest level of BMC/IMM](#)

**• 264-904-000 : Tape Test Failed**

Tape Test Failed. Drive hardware error.

**Recoverable**

No

**Severity**

Error

**Serviceable**

Yes

**Automatically notify support**

No

**User Response**

Complete the following steps:

1. Check the tape drive cabling for loose or broken connections or damage to the cable. Replace the cable if damage is present.

2. Clean the tape drive using the appropriate cleaning media and install new media.
3. Run the test again.
4. Make sure that the drive firmware is at the latest level.
5. Rerun the test after upgrading to the latest firmware level.
6. If the failure remains, refer to "Troubleshooting by symptom" in the system "Installation and Service Guide" for the next corrective action.

**Related links**

- [IBM Support website](#)
- [Latest level of DSA](#)
- [Latest level of BMC/IMM](#)

**• 264-905-000 : Tape Test Failed**

Tape Test Failed. Software error: invalid request.

**Recoverable**

No

**Severity**

Error

**Serviceable**

Yes

**Automatically notify support**

No

**User Response**

Complete the following steps:

1. If the system has stopped responding, turn off and restart the system.
2. Check the system firmware level and upgrade if necessary. The installed firmware level can be found in the DSA Diagnostic Event Log within the Firmware/VPD section for this component.
3. Run the test again.
4. If the system has stopped responding, turn off and restart the system.
5. Make sure that the drive firmware is at the latest level.
6. Run the test again.
7. If the failure remains, refer to "Troubleshooting by symptom" in the system "Installation and Service Guide" for the next corrective action.

**Related links**

- [IBM Support website](#)
- [Latest level of DSA](#)
- [Latest level of BMC/IMM](#)

**• 264-906-000 : Tape Test Failed**

Tape Test Failed. Unrecognized error.

**Recoverable**

No

**Severity**

Error

**Serviceable**

Yes

**Automatically notify support**

No

**User Response**

Complete the following steps:

1. Clean the tape drive using the appropriate cleaning media and install new media.
2. Run the test again.
3. Make sure that the drive firmware is at the latest level.
4. Rerun the test after upgrading to the latest firmware level.
5. Make sure that the DSA Diagnostic code is at the latest level.
6. Run the test again.
7. Check the system firmware level and upgrade if necessary.
8. Run the test again.
9. If the failure remains, refer to "Troubleshooting by symptom" in the system "Installation and Service Guide" for the next corrective action.

**Related links**

- [IBM Support website](#)
  - [Latest level of DSA](#)
  - [Latest level of BMC/IMM](#)
- **264-907-000 : Tape Test Failed**

An error was found in the block address somewhere.

**Recoverable**

No

**Severity**

Error

**Serviceable**

Yes

**Automatically notify support**

No

**User Response**

Complete the following steps:

1. Clean the tape drive using the appropriate cleaning media and install new media.

**Related links**

- [IBM Support website](#)
  - [Latest level of DSA](#)
  - [Latest level of BMC/IMM](#)
- **264-908-000 : Tape Test Failed**

An error was found in getting tape capacity.

**Recoverable**

No

**Severity**

Error

**Serviceable**

Yes

**Automatically notify support**

No

**User Response**

Complete the following steps:

1. Make sure that medium is present.
2. Clean the tape drive using the appropriate cleaning media and install new media.

**Related links**

- [IBM Support website](#)
- [Latest level of DSA](#)
- [Latest level of BMC/IMM](#)



---

## Appendix D. Getting help and technical assistance

If you need help, service, or technical assistance or just want more information about Lenovo products, you will find a wide variety of sources available from Lenovo to assist you.

Use this information to obtain additional information about Lenovo and Lenovo products, and determine what to do if you experience a problem with your Lenovo system or optional device.

**Note:** This section includes references to IBM web sites and information about obtaining service. IBM is Lenovo's preferred service provider for the System x, Flex System, and NeXtScale System products.

---

### Before you call

Before you call, make sure that you have taken these steps to try to solve the problem yourself.

If you believe that you require warranty service for your Lenovo product, the service technicians will be able to assist you more efficiently if you prepare before you call.

- Check all cables to make sure that they are connected.
- Check the power switches to make sure that the system and any optional devices are turned on.
- Check for updated software, firmware, and operating-system device drivers for your Lenovo product. The Lenovo Warranty terms and conditions state that you, the owner of the Lenovo product, are responsible for maintaining and updating all software and firmware for the product (unless it is covered by an additional maintenance contract). Your service technician will request that you upgrade your software and firmware if the problem has a documented solution within a software upgrade.
- If you have installed new hardware or software in your environment, check <http://www.lenovo.com/serverproven/> to make sure that the hardware and software is supported by your product.
- Go to <http://www.lenovo.com/support> to check for information to help you solve the problem.
- Gather the following information to provide to the service technician. This data will help the service technician quickly provide a solution to your problem and ensure that you receive the level of service for which you might have contracted.
  - Hardware and Software Maintenance agreement contract numbers, if applicable
  - Machine type number (Lenovo 4-digit machine identifier)
  - Model number
  - Serial number
  - Current system UEFI and firmware levels
  - Other pertinent information such as error messages and logs
- Go to [http://www.ibm.com/support/entry/portal/Open\\_service\\_request](http://www.ibm.com/support/entry/portal/Open_service_request) to submit an Electronic Service Request. Submitting an Electronic Service Request will start the process of determining a solution to your problem by making the pertinent information available to the service technicians. The IBM service technicians can start working on your solution as soon as you have completed and submitted an Electronic Service Request.

You can solve many problems without outside assistance by following the troubleshooting procedures that Lenovo provides in the online help or in the Lenovo product documentation. The Lenovo product documentation also describes the diagnostic tests that you can perform. The documentation for most systems, operating systems, and programs contains troubleshooting procedures and explanations of error messages and error codes. If you suspect a software problem, see the documentation for the operating system or program.

---

## Using the documentation

Information about your Lenovo system and preinstalled software, if any, or optional device is available in the product documentation. That documentation can include printed documents, online documents, readme files, and help files.

See the troubleshooting information in your system documentation for instructions for using the diagnostic programs. The troubleshooting information or the diagnostic programs might tell you that you need additional or updated device drivers or other software. Lenovo maintains pages on the World Wide Web where you can get the latest technical information and download device drivers and updates. To access these pages, go to <http://www.lenovo.com/support>.

---

## Getting help and information from the World Wide Web

Up-to-date information about Lenovo products and support is available on the World Wide Web.

On the World Wide Web, up-to-date information about Lenovo systems, optional devices, services, and support is available at <http://www.lenovo.com/support>. The most current version of the product documentation is available in the following product-specific Information Centers:

- **Flex System products:**  
<http://pic.dhe.ibm.com/infocenter/flexsys/information/index.jsp>
- **System x products:**  
<http://shop.lenovo.com/us/en/systems/>
- **NeXtScale System products:**  
<http://pic.dhe.ibm.com/infocenter/nxtscale/documentation/index.jsp>

---

## How to send DSA data

You can use the Enhanced Customer Data Repository to send diagnostic data to IBM.

Before you send diagnostic data to IBM, read the terms of use at <http://www.ibm.com/de/support/ecurep/terms.html>.

You can use any of the following methods to send diagnostic data:

- **Standard upload:**  
[http://www.ibm.com/de/support/ecurep/send\\_http.html](http://www.ibm.com/de/support/ecurep/send_http.html)
- **Standard upload with the system serial number:**  
[http://www.ecurep.ibm.com/app/upload\\_hw](http://www.ecurep.ibm.com/app/upload_hw)
- **Secure upload:**  
[http://www.ibm.com/de/support/ecurep/send\\_http.html#secure](http://www.ibm.com/de/support/ecurep/send_http.html#secure)
- **Secure upload with the system serial number:**  
[https://www.ecurep.ibm.com/app/upload\\_hw](https://www.ecurep.ibm.com/app/upload_hw)

---

## Creating a personalized support web page

You can create a personalized support web page by identifying Lenovo products that are of interest to you.

To create a personalized support web page, go to <http://www.ibm.com/support/mynotifications>. From this personalized page, you can subscribe to weekly email notifications about new technical documents, search for information and downloads, and access various administrative services.

---

## Software service and support

Through IBM Support Line, you can get telephone assistance, for a fee, with usage, configuration, and software problems with your Lenovo products.

For more information about Support Line and other IBM services, see <http://www.ibm.com/services> or see <http://www.ibm.com/planetwide> for support telephone numbers. In the U.S. and Canada, call 1-800-IBM-SERV (1-800-426-7378).

---

## Hardware service and support

IBM is Lenovo's preferred service provider for the System x, Flex System and NeXtScale System products.

You can receive hardware service through your Lenovo reseller or from IBM. To locate a reseller authorized by Lenovo to provide warranty service, go to <http://www.ibm.com/partnerworld> and click **Business Partner Locator**. For IBM support telephone numbers, see <http://www.ibm.com/planetwide>. In the U.S. and Canada, call 1-800-IBM-SERV (1-800-426-7378).

In the U.S. and Canada, hardware service and support is available 24 hours a day, 7 days a week. In the U.K., these services are available Monday through Friday, from 9 a.m. to 6 p.m.

---

## Taiwan product service

Use this information to contact IBM Taiwan product service.

台灣 IBM 產品服務聯絡方式：  
台灣國際商業機器股份有限公司  
台北市松仁路 7 號 3 樓  
電話：0800-016-888

IBM Taiwan product service contact information:

IBM Taiwan Corporation  
3F, No 7, Song Ren Rd.  
Taipei, Taiwan  
Telephone: 0800-016-888



---

## Appendix E. Notices

Lenovo may not offer the products, services, or features discussed in this document in all countries. Consult your local Lenovo representative for information on the products and services currently available in your area.

Any reference to a Lenovo product, program, or service is not intended to state or imply that only that Lenovo product, program, or service may be used. Any functionally equivalent product, program, or service that does not infringe any Lenovo intellectual property right may be used instead. However, it is the user's responsibility to evaluate and verify the operation of any other product, program, or service.

Lenovo may have patents or pending patent applications covering subject matter described in this document. The furnishing of this document does not give you any license to these patents. You can send license inquiries, in writing, to:

*Lenovo (United States), Inc.  
1009 Think Place - Building One  
Morrisville, NC 27560  
U.S.A.  
Attention: Lenovo Director of Licensing*

LENOVO PROVIDES THIS PUBLICATION "AS IS" WITHOUT WARRANTY OF ANY KIND, EITHER EXPRESS OR IMPLIED, INCLUDING, BUT NOT LIMITED TO, THE IMPLIED WARRANTIES OF NON-INFRINGEMENT, MERCHANTABILITY OR FITNESS FOR A PARTICULAR PURPOSE. Some jurisdictions do not allow disclaimer of express or implied warranties in certain transactions, therefore, this statement may not apply to you.

This information could include technical inaccuracies or typographical errors. Changes are periodically made to the information herein; these changes will be incorporated in new editions of the publication. Lenovo may make improvements and/or changes in the product(s) and/or the program(s) described in this publication at any time without notice.

The products described in this document are not intended for use in implantation or other life support applications where malfunction may result in injury or death to persons. The information contained in this document does not affect or change Lenovo product specifications or warranties. Nothing in this document shall operate as an express or implied license or indemnity under the intellectual property rights of Lenovo or third parties. All information contained in this document was obtained in specific environments and is presented as an illustration. The result obtained in other operating environments may vary.

Lenovo may use or distribute any of the information you supply in any way it believes appropriate without incurring any obligation to you.

Any references in this publication to non-Lenovo Web sites are provided for convenience only and do not in any manner serve as an endorsement of those Web sites. The materials at those Web sites are not part of the materials for this Lenovo product, and use of those Web sites is at your own risk.

Any performance data contained herein was determined in a controlled environment. Therefore, the result obtained in other operating environments may vary significantly. Some measurements may have been made on development-level systems and there is no guarantee that these measurements will be the same on generally available systems. Furthermore, some measurements may have been estimated through extrapolation. Actual results may vary. Users of this document should verify the applicable data for their specific environment.

---

## Trademarks

Lenovo, the Lenovo logo, Flex System, System x, NeXtScale System, and x Architecture are trademarks of Lenovo in the United States, other countries, or both.

Intel and Intel Xeon are trademarks of Intel Corporation in the United States, other countries, or both.

Internet Explorer, Microsoft, and Windows are trademarks of the Microsoft group of companies.

Linux is a registered trademark of Linus Torvalds.

Other company, product, or service names may be trademarks or service marks of others.

---

## Important notes

Processor speed indicates the internal clock speed of the microprocessor; other factors also affect application performance.

CD or DVD drive speed is the variable read rate. Actual speeds vary and are often less than the possible maximum.

When referring to processor storage, real and virtual storage, or channel volume, KB stands for 1 024 bytes, MB stands for 1 048 576 bytes, and GB stands for 1 073 741 824 bytes.

When referring to hard disk drive capacity or communications volume, MB stands for 1 000 000 bytes, and GB stands for 1 000 000 000 bytes. Total user-accessible capacity can vary depending on operating environments.

Maximum internal hard disk drive capacities assume the replacement of any standard hard disk drives and population of all hard-disk-drive bays with the largest currently supported drives that are available from Lenovo.

Maximum memory might require replacement of the standard memory with an optional memory module.

Each solid-state memory cell has an intrinsic, finite number of write cycles that the cell can incur. Therefore, a solid-state device has a maximum number of write cycles that it can be subjected to, expressed as total bytes written (TBW). A device that has exceeded this limit might fail to respond to system-generated commands or might be incapable of being written to. Lenovo is not responsible for replacement of a device that has exceeded its maximum guaranteed number of program/erase cycles, as documented in the Official Published Specifications for the device.

Lenovo makes no representations or warranties with respect to non-Lenovo products. Support (if any) for the non-Lenovo products is provided by the third party, not Lenovo.

Some software might differ from its retail version (if available) and might not include user manuals or all program functionality.

---

## Recycling information

Lenovo encourages owners of information technology (IT) equipment to responsibly recycle their equipment when it is no longer needed. Lenovo offers a variety of programs and services to assist equipment owners in recycling their IT products. For information on recycling Lenovo products, go to: <http://www.lenovo.com/recycling>.

---

## Particulate contamination

**Attention:** Airborne particulates (including metal flakes or particles) and reactive gases acting alone or in combination with other environmental factors such as humidity or temperature might pose a risk to the device that is described in this document.

Risks that are posed by the presence of excessive particulate levels or concentrations of harmful gases include damage that might cause the device to malfunction or cease functioning altogether. This specification sets forth limits for particulates and gases that are intended to avoid such damage. The limits must not be viewed or used as definitive limits, because numerous other factors, such as temperature or moisture content of the air, can influence the impact of particulates or environmental corrosives and gaseous contaminant transfer. In the absence of specific limits that are set forth in this document, you must implement practices that maintain particulate and gas levels that are consistent with the protection of human health and safety. If Lenovo determines that the levels of particulates or gases in your environment have caused damage to the device, Lenovo may condition provision of repair or replacement of devices or parts on implementation of appropriate remedial measures to mitigate such environmental contamination. Implementation of such remedial measures is a customer responsibility.

Table 22. Limits for particulates and gases

Contaminant	Limits
Particulate	<ul style="list-style-type: none"><li>The room air must be continuously filtered with 40% atmospheric dust spot efficiency (MERV 9) according to ASHRAE Standard 52.2<sup>1</sup>.</li><li>Air that enters a data center must be filtered to 99.97% efficiency or greater, using high-efficiency particulate air (HEPA) filters that meet MIL-STD-282.</li><li>The deliquescent relative humidity of the particulate contamination must be more than 60%<sup>2</sup>.</li><li>The room must be free of conductive contamination such as zinc whiskers.</li></ul>
Gaseous	<ul style="list-style-type: none"><li>Copper: Class G1 as per ANSI/ISA 71.04-1985<sup>3</sup></li><li>Silver: Corrosion rate of less than 300 Å in 30 days</li></ul>
<p><sup>1</sup> ASHRAE 52.2-2008 - <i>Method of Testing General Ventilation Air-Cleaning Devices for Removal Efficiency by Particle Size</i>. Atlanta: American Society of Heating, Refrigerating and Air-Conditioning Engineers, Inc.</p> <p><sup>2</sup> The deliquescent relative humidity of particulate contamination is the relative humidity at which the dust absorbs enough water to become wet and promote ionic conduction.</p> <p><sup>3</sup> ANSI/ISA-71.04-1985. <i>Environmental conditions for process measurement and control systems: Airborne contaminants</i>. Instrument Society of America, Research Triangle Park, North Carolina, U.S.A.</p>	

---

## Telecommunication regulatory statement

This product may not be certified in your country for connection by any means whatsoever to interfaces of public telecommunications networks. Further certification may be required by law prior to making any such connection. Contact a Lenovo representative or reseller for any questions.

---

## Electronic emission notices

When you attach a monitor to the equipment, you must use the designated monitor cable and any interference suppression devices that are supplied with the monitor.

## Federal Communications Commission (FCC) statement

**Note:** This equipment has been tested and found to comply with the limits for a Class A digital device, pursuant to Part 15 of the FCC Rules. These limits are designed to provide reasonable protection against harmful interference when the equipment is operated in a commercial environment. This equipment generates, uses, and can radiate radio frequency energy and, if not installed and used in accordance with the instruction manual, may cause harmful interference to radio communications. Operation of this equipment in a residential area is likely to cause harmful interference, in which case the user will be required to correct the interference at his own expense.

Properly shielded and grounded cables and connectors must be used in order to meet FCC emission limits. Lenovo is not responsible for any radio or television interference caused by using other than recommended cables and connectors or by unauthorized changes or modifications to this equipment. Unauthorized changes or modifications could void the user's authority to operate the equipment.

This device complies with Part 15 of the FCC Rules. Operation is subject to the following two conditions: (1) this device may not cause harmful interference, and (2) this device must accept any interference received, including interference that might cause undesired operation.

## Industry Canada Class A emission compliance statement

This Class A digital apparatus complies with Canadian ICES-003.

## Avis de conformité à la réglementation d'Industrie Canada

Cet appareil numérique de la classe A est conforme à la norme NMB-003 du Canada.

## Australia and New Zealand Class A statement

**Attention:** This is a Class A product. In a domestic environment this product may cause radio interference in which case the user may be required to take adequate measures.

## European Union EMC Directive conformance statement

This product is in conformity with the protection requirements of EU Council Directive 2014/30/EU on the approximation of the laws of the Member States relating to electromagnetic compatibility. Lenovo cannot accept responsibility for any failure to satisfy the protection requirements resulting from a non-recommended modification of the product, including the installation of option cards from other manufacturers.

This product has been tested and found to comply with the limits for Class A equipment according to European Standards harmonized in the Directives in compliance. The limits for Class A equipment were derived for commercial and industrial environments to provide reasonable protection against interference with licensed communication equipment.

Lenovo, Einsteinova 21, 851 01 Bratislava, Slovakia



**Warning:** This is a Class A product. In a domestic environment this product may cause radio interference in which case the user may be required to take adequate measures.

## Germany Class A statement

**Deutschsprachiger EU Hinweis: Hinweis für Geräte der Klasse A EU-Richtlinie zur Elektromagnetischen Verträglichkeit**



### **Deutschsprachiger EU Hinweis: Hinweis für Geräte der Klasse A EU-Richtlinie zur**

**Elektromagnetischen Verträglichkeit** Dieses Produkt entspricht den Schutzanforderungen der EU-Richtlinie 2014/30/EU (früher 2004/108/EC) zur Angleichung der Rechtsvorschriften über die elektromagnetische Verträglichkeit in den EU-Mitgliedsstaaten und hält die Grenzwerte der Klasse A der Norm gemäß Richtlinie.

Um dieses sicherzustellen, sind die Geräte wie in den Handbüchern beschrieben zu installieren und zu betreiben. Des Weiteren dürfen auch nur von der Lenovo empfohlene Kabel angeschlossen werden. Lenovo übernimmt keine Verantwortung für die Einhaltung der Schutzanforderungen, wenn das Produkt ohne Zustimmung der Lenovo verändert bzw. wenn Erweiterungskomponenten von Fremdherstellern ohne Empfehlung der Lenovo gesteckt/eingebaut werden.

### **Deutschland:**

**Einhaltung des Gesetzes über die elektromagnetische Verträglichkeit von Betriebsmitteln** Dieses Produkt entspricht dem „Gesetz über die elektromagnetische Verträglichkeit von Betriebsmitteln“ EMVG (früher „Gesetz über die elektromagnetische Verträglichkeit von Geräten“). Dies ist die Umsetzung der EU-Richtlinie 2014/30/EU (früher 2004/108/EC) in der Bundesrepublik Deutschland.

**Zulassungsbescheinigung laut dem Deutschen Gesetz über die elektromagnetische Verträglichkeit von Betriebsmitteln, EMVG vom 20. Juli 2007 (früher Gesetz über die elektromagnetische Verträglichkeit von Geräten), bzw. der EMV EU Richtlinie 2014/30/EU (früher 2004/108/EC), für Geräte der Klasse A.**

Dieses Gerät ist berechtigt, in Übereinstimmung mit dem Deutschen EMVG das EG-Konformitätszeichen - CE - zu führen. Verantwortlich für die Konformitätserklärung nach Paragraf 5 des EMVG ist die Lenovo (Deutschland) GmbH, Meitnerstr. 9, D-70563 Stuttgart.

Informationen in Hinsicht EMVG Paragraf 4 Abs. (1) 4: **Das Gerät erfüllt die Schutzanforderungen nach EN 55024 und EN 55022 Klasse A.**

Nach der EN 55022: „Dies ist eine Einrichtung der Klasse A. Diese Einrichtung kann im Wohnbereich Funkstörungen verursachen; in diesem Fall kann vom Betreiber verlangt werden, angemessene Maßnahmen durchzuführen und dafür aufzukommen.“

Nach dem EMVG: „Geräte dürfen an Orten, für die sie nicht ausreichend entstört sind, nur mit besonderer Genehmigung des Bundesministers für Post und Telekommunikation oder des Bundesamtes für Post und Telekommunikation betrieben werden. Die Genehmigung wird erteilt, wenn keine elektromagnetischen Störungen zu erwarten sind.“ (Auszug aus dem EMVG, Paragraph 3, Abs. 4). Dieses Genehmigungsverfahren ist nach Paragraph 9 EMVG in Verbindung mit der entsprechenden Kostenverordnung (Amtsblatt 14/93) kostenpflichtig.

Anmerkung: Um die Einhaltung des EMVG sicherzustellen sind die Geräte, wie in den Handbüchern angegeben, zu installieren und zu betreiben.

### **Japanese electromagnetic compatibility statements**

Pseudo topic: DITA topic "file:/\_ATI\_Not\_Found\_/kh9\_r\_jp\_emc\_statements.dita" not found

## Korea Communications Commission (KCC) statement

이 기기는 업무용(A급)으로 전자파적합기기로서 판매자 또는 사용자는 이 점을 주의하시기 바라며, 가정외의 지역에서 사용하는 것을 목적으로 합니다.

This is electromagnetic wave compatibility equipment for business (Type A). Sellers and users need to pay attention to it. This is for any areas other than home.

## Russia Electromagnetic Interference (EMI) Class A statement

### ВНИМАНИЕ!

Настоящее изделие относится к оборудованию класса А. При использовании в бытовой обстановке это оборудование может нарушать функционирование других технических средств в результате создаваемых промышленных радиопомех. В этом случае от пользователя может потребоваться принятие адекватных мер.

## People's Republic of China Class A electronic emission statement

### 声 明

此为 A 级产品。在生活环境中，该产品可能会造成无线电干扰。在这种情况下，可能需要用户对其干扰采取切实可行的措施。

## Taiwan Class A compliance statement

警告使用者：  
這是甲類的資訊產品，在居住的環境中使用時，可能會造成射頻干擾，在這種情況下，使用者會被要求採取某些適當的對策。

## Taiwan BSMI RoHS declaration

單元 Unit	限用物質及其化學符號 Restricted substances and its chemical symbols					
	鉛Lead (Pb)	汞Mercury (Hg)	鎘Cadmium (Cd)	六價鉻 Hexavalent chromium (Cr <sup>6+</sup> )	多溴聯苯 Polybrominated biphenyls (PBB)	多溴二苯醚 Polybrominated diphenyl ethers (PBDE)
機架	○	○	○	○	○	○
外部蓋板	○	○	○	○	○	○
機械組合作件	○	○	○	○	○	○
空氣傳動設備	-	○	○	○	○	○
冷卻組合作件	-	○	○	○	○	○
內存模塊	-	○	○	○	○	○
處理器模塊	-	○	○	○	○	○
鍵盤	-	○	○	○	○	○
調製解調器	-	○	○	○	○	○
監視器	-	○	○	○	○	○
滑鼠	-	○	○	○	○	○
電纜組合作件	-	○	○	○	○	○
電源	-	○	○	○	○	○
儲備設備	-	○	○	○	○	○
電池匣組合作件	-	○	○	○	○	○
電池	-	○	○	○	○	○
有mech的電路卡	-	○	○	○	○	○
無mech的電路卡	-	○	○	○	○	○
雷射器	-	○	○	○	○	○
<p>備考1. “超出0.1 wt %” 及 “超出0.01 wt %” 係指限用物質之百分比含量超出百分比含量基準值。            Note1 : “exceeding 0.1wt%” and “exceeding 0.01 wt%” indicate that the percentage content of the restricted substance exceeds the reference percentage value of presence condition.</p> <p>備考2. “○” 係指該項限用物質之百分比含量未超出百分比含量基準值。            Note2 : “○” indicates that the percentage content of the restricted substance does not exceed the percentage of reference value of presence.</p> <p>備考3. “-” 係指該項限用物質為排除項目。            Note3 : The “-” indicates that the restricted substance corresponds to the exemption.</p>						



---

# Index

- 2.5-inch advanced operation panel assembly, installing 309
- 2.5-inch hard disk drive
  - cable connection 132
- 2.5-inch hard disk drive cable connection 132
- 2.5-inch hot-swap hard disk drive
  - backplanes 36
- 2.5-inch simple-swap hard disk drive backplate assemblies 36
- 2.5-inch/3.5-inch simple-swap/hot-swap hard disk drive
  - backplate assemblies and backplanes 36
- 3.5-inch hot-swap hard disk drive
  - backplanes 36
- 3.5-inch simple-swap hard disk drive backplate assemblies 36
- 4x 2.5-inch NVMe PCIe SSD upgrade kit, installing 305
- 8x 2.5-inch hot-swap HDD assembly kit
  - installing 293
- 8x 2.5-inch hot-swap HDD assembly kit, installing 293
- 8x 2.5-inch hot-swap HDD assembly with expander kit
  - installing 299
- 8x 2.5-inch hot-swap HDD assembly with expander kit, installing 299
- 8x 2.5-inch simple-swap HDD ServeRAID assembly kit
  - installing 289
- 8x 2.5-inch simple-swap HDD ServeRAID assembly kit, installing 289
- 8x 3.5-inch simple-swap HDD ServeRAID assembly kit
  - installing 291
- 8x 3.5-inch simple-swap HDD ServeRAID assembly kit, installing 291

## A

- ABR, automatic boot recovery 109
- AC power-supply
  - LEDs 69
- AC power-supply LEDs 69
- acoustical noise emissions 6
- active memory 13
- adapter
  - removing 185, 187
    - in a riser-card assembly 185
    - rear two hard-disk-drive kit 188
  - replacing 189, 195–196
- adapter, installation 189, 196
  - PCI expansion slot 4 or slot 5 195
- adapter, supported 189, 195–196
- air baffle
  - removing 147
  - replacing 148
- an optical drive
  - removing 161
- ASM event log 74
- assertion event, system-event log 73
- assistance, getting 1149
- attention notices 6
- Australia Class A statement 1156
- automatic boot recovery (ABR) 109
- availability, server 16

## B

- backup firmware
  - starting 51
- battery, system
  - removing 247
  - replacing 250
- before you install a legacy operating system 46

- blue-screen capture feature
  - overview 53
- blue-screen feature 53
- Boot Manager 51
- Boot Manager program 44
- button, presence detection 20
- buttons
  - system board 30

## C

- cabling 131
  - 12x3.5-inch drive backplane 143
  - 3.5-inch drive backplane 141
  - 8x3.5-inch drive backplane 141
  - the 16x2.5-inch hot-swap drive backplane 134
  - the 24x2.5-inch hot-swap drive backplane 137
  - the 8x2.5-inch hot-swap drive backplane 132
  - VGA 131
- call home feature
  - Electronic Service Agent 78
- call home tools 78
- Canada Class A electronic emission statement 1156
- caution statements 6
- checkout procedure 66
  - performing 66
- China Class A electronic emission statement 1158
- Class A electronic emission notice 1156
- collecting data 63
- components
  - server 27, 111
- configuration
  - information 43
  - instructions 43
  - Nx-boot failure 110
  - ServerGuide Setup and Installation CD 43
  - Setup Utility 43
- configuration cable,
  - routing 132, 134, 137, 141, 143
- configuration programs 44
- configuring
  - RAID arrays 56
    - with ServerGuide 46
  - configuring hardware 44
  - configuring your server 43
- connector
  - USB 18
  - video
    - front 18
- connectors
  - external 28
  - internal 28
    - options on the system board 29
- consumable parts 127
- contamination, particulate and gaseous 1155
- controller
  - Ethernet 55
- controls and LEDs
  - operator information panel 20
- controls, LEDs, and power 18
- cooling 13
- creating a personalized support web page 1150
- custom support web page 1150

## D

- danger statements 6
- data collection 63
- DC power-supply
  - LEDs 70
- DC power-supply LEDs 70
- deassertion event, system-event log 73
- dedicated slotless RAID controller
  - removing 183
  - replacing 184
- device drivers 51
- devices, static-sensitive
  - handling 289
- diagnostic
  - on-board programs, starting 76
  - tools, overview 67
- diagnostic codes and messages
  - POST/UEFI 991
- diagnostics
  - program overview 75
- diagnostics program
  - DSA Preboot 13
- dimension 6
- DIMM
  - installing 165
  - memory
    - two-DIMM-per-channel (2DPC) 165
  - removing 165
  - replacing 171
  - two-DIMM-per-channel (2DPC)
    - requirement 165
- DIMM installation sequence 168
- memory mirrored channel 169
- rank sparing 170
- display problems 86
- documentation 5
  - CD 4
  - Documentation Browser 5
  - updates 1
  - using 1150
- documentation, updated
  - finding 5
- drive backplane, 12x3.5-inch
  - cabling 143
- drive backplane, 16x2.5-inch hot-swap
  - cabling 134
- drive backplane, 24x2.5-inch hot-swap
  - cabling 137
- drive backplane, 3.5-inch
  - cabling 141
- drive backplane, 8x2.5-inch hot-swap
  - cabling 132
- drive backplane, 8x3.5-inch
  - cabling 141
- DSA 311
  - program, overview 75
  - test log, viewing 77
  - text message format 77
- DSA log 73
- DSA Preboot 67, 76
- DSA, sending data 311, 1150
- DVD
  - drive activity LED 18
  - eject button 18
- DVD drive
  - problems 78
- Dynamic System Analysis 311
- Dynamic System Analysis (DSA) Preboot diagnostics
  - program 13

## E

- EIA

- removing 206
- replacing 216
- electronic emission Class A notice 1156
- Electronic Service Agent 78
- embedded hypervisor
  - using 55
- enabling
  - Features on Demand
    - Ethernet software 56
    - RAID software 56
- Enterprise X-Architecture technology 13
- error codes and messages
  - IMM2 313
- error messages 78
- error symptoms
  - DVD drive 78
  - general 79
  - hard disk drive 80
  - hypervisor flash device 82
  - intermittent 83
  - keyboard 83
  - memory 84
  - microprocessor 86
  - monitor 86
  - mouse 83
  - network connection 88
  - optional devices 89
  - power 90
  - serial port 99
  - ServerGuide 100
  - software 101
  - USB connector 101
  - USB-device 83
  - video 86, 102
- errors
  - format, DSA code 77
- Ethernet 13
  - controller 105
- Ethernet controller configuration 44
- Ethernet support 13
- European Union EMC Directive conformance statement 1156
- event log 73
  - viewing 74
- event log, POST 73
- event log, system 73
- event logs
  - clearing 75
- event logs, methods for viewing 74
- expansion slot locations 26
- external connectors 28

## F

- fan cage assembly
  - removing 172
  - replacing 173
- fans 13
- FCC Class A notice 1156
- features 6
  - ServerGuide 45
- Features on Demand 13
- finding
  - updated documentation 5
- firmware
  - updates 1
- firmware updates 1
- firmware, server, recovering 107
- firmware, updating 43
- front
  - view 18
- front USB assembly
  - removing 151
  - replacing 152

front view  
connectors 18  
LED location 18

## G

gaseous contamination 1155  
general  
problems 79  
Germany Class A statement 1156  
grease, thermal 279  
guidelines  
options installation 287  
system reliability 288

## H

handling static-sensitive devices 289  
hard disk drive  
activity LED 18  
problems 80  
status LED 18  
hardware  
requirements 4  
hardware RAID cable,  
routing 132, 134, 137, 141, 143  
hardware service and support telephone numbers 1151  
hardware, configuring 44  
heat sink  
removing 265  
replacing 270  
heat-sink retention module  
removing 280  
replacing 280  
help  
from the World Wide Web 1150  
from World Wide Web 1150  
sending diagnostic data 311, 1150  
sources of 1149  
hot-swap ac power supply  
removing 228  
replacing 230  
hot-swap dc power supply  
replacing 236  
hot-swap drive backplane  
removing 241, 243  
replacing 242  
simple-swap drive backplate assembly 242  
simple-swap drive backplate assembly  
replacing 242  
hot-swap fan  
removing 174  
replacing 175  
hot-swap hard disk drive  
replacing 154  
hot-swap hard disk drives  
removing 153  
hypervisor flash device  
problems 82

## I

IMM host name 53  
IMM2 44  
error messages 313  
IMM2 heartbeat  
LED 72  
IMM2 Web interface 54  
important notices 6, 1154  
in-band

automated boot recovery method 109  
manual recovery method 108  
information center 1150  
installation  
guidelines 287  
installation guidelines 287  
installing  
2.5-inch advanced operation panel assembly 309  
4x 2.5-inch NVMe PCIe SSD upgrade kit 305  
8x 2.5-inch hot-swap HDD assembly kit 293  
8x 2.5-inch hot-swap HDD assembly with expander kit 299  
8x 2.5-inch simple-swap HDD ServeRAID assembly kit 289  
8x 3.5-inch simple-swap HDD ServeRAID assembly kit 291  
components 131  
DIMM 165  
lightpath LCD operation panel assembly 178  
media cage 178  
memory module 165  
optional devices 286  
PCIe thermal solution kit 308  
instructions  
Business Partners 311  
integrated management module  
overview 13  
using 51  
integrated management module II  
error messages 313  
event log 73–74  
programs 44  
intermittent  
problems 83  
internal connectors 28  
introduction 1  
IP address for the IMM 54  
IPMI event log 73–74  
IPMItool 74

## J

jumper  
UEFI boot recovery 107  
jumpers  
system board 30

## K

Korea Class A electronic emission statement 1158

## L

LCD  
system information display panel 21  
LCD system information display panel 21  
removing 253  
replacing 256  
LED 20  
DVD drive activity 18  
hard disk drive activity 18  
hard disk drive status 18  
IMM2 heartbeat 72  
power-on 20  
RTMM heartbeat 72  
system information 20  
system locator 20  
system-error 20  
LEDs  
AC power-supply 69  
DC power-supply 70  
on the PCI riser-card 73  
power-supply 69

- riser-card assembly 35
- system board 33
- legacy operating system
  - requirement 46
- Lenovo ToolsCenter Suite CLI 13
- Lenovo ToolsCenter Suite CLI program
  - overview 56
- Lenovo XClarity Administrator 13
  - updating 57
- Lenovo XClarity Energy Manager 13
- License Agreement for Machine Code 5
- Licenses and Attributions Documents 5
- light path diagnostics 13
- light path diagnostics panel
  - location 18
- lightpath LCD operation panel assembly
  - installing 178
  - removing 176
- local area network (LAN) 13
- logging 54

## M

- management, system 13
- media cage
  - installing 178
  - removing 176
- memory 13
- memory mirrored channel
  - description 169
  - DIMM population sequence 169
- memory module
  - installing 165
  - removing 165
- memory rank sparing
  - description 170
- memory support 13
- menu choices
  - Setup utility 47
- messages, diagnostic
  - POST/UEFI 991
- method 109
- methods, viewing event logs 74
- microprocessor 13
  - problems 86
  - removing 265
  - replacing 270
- mirrored channel mode 169
- model name
  - location 106

## N

- New Zealand Class A statement 1156
- NMI button 24
- NOS installation
  - with ServerGuide 46
  - without ServerGuide 46
- notes 6
- notes, important 1154
- notices 1153
  - electronic emission 1156
  - FCC, Class A 1156
- notices and statements 6
- Nx-boot failure 110

## O

- obtaining 53–54
- OneCLI log 74

- online documentation 1
- online publications 5
- operating-system event log 73–74
- operator information panel
  - controls and LEDs 20
  - removing 262
  - replacing 263
- operator information panel release latch 18
- Optical drive
  - replacing 162
- optical drive cable
  - removing 159
  - replacing 160
- optional device problems 89
- optional devices
  - installing 286
- optional devices connectors
  - system board 29
- out-of-band 109

## P

- particulate contamination 1155
- parts listing 111
- parts, consumable 127
- parts, structural 127
- PCI riser slots
  - installation configurations 189
  - supported configurations 189
- PCI riser-card
  - LEDs location 73
  - slot connectors 33
- PCI riser-card adapter expansion slot connectors 33
- PCI riser-card adapter expansion slot locations 26
- PCIe thermal solution kit
  - installing 308
- PCIe thermal solution kit, installing 308
- People's Republic of China Class A electronic emission statement 1158
- POST
  - event log 74
  - POST event log 73
- POST/UEFI
  - diagnostic codes 991
- power
  - power-control button 20
- power cable,
  - routing 132, 134, 137, 141, 143
- power cords 128
- power features
  - server 39
- power paddle module
  - removing 149
  - replacing 150
- power problems 90, 102
- power-on LED 20, 39
- power-supply
  - LEDs 69
- power-supply LEDs 69
- presence detection button 20
- problems
  - DVD drive 78
  - Ethernet controller 105
  - general 79
  - hard disk drive 80
  - hypervisor flash device 82
  - IMM2 313
  - intermittent 83
  - keyboard 83
  - memory 84
  - microprocessor 86
  - monitor 86
  - mouse 83



- network connection 88
- optional devices 89
- power 90, 102
- serial port 99
- ServerGuide 100
- software 101
- undetermined 105
- USB connector 101
- video 86, 102
- procedure, checkout 66
- product service, Taiwan 1151
- program
  - Lenovo ToolsCenter Suite CLI 56
- publications
  - online 1
  - product data 1

## R

- rack
  - specifications 12
- rack release latches 18
- RAID adapter
  - remote battery
    - removing 197
    - replacing 198
- RAID arrays
  - configuring 56
- rail
  - specifications 12
- rank sparing
  - DIMM population sequence 170
- rank sparing mode 170
- RAS features, server 16
- rear
  - view 24
- rear two hard-disk-drive kit
  - removing 200
  - replacing 201
- rear view
  - connectors 24
  - LED location 24
- recovering the server firmware 107
- redundant
  - cooling 13
  - Ethernet connection 13
  - NIC 13
- Redundant
  - Ethernet capabilities 16
  - hot-swap power supplies 16
- reliability, server 16
- remote battery, RAID adapter
  - removing 197
  - replacing 198
- remote presence feature
  - using 53
- removing
  - a riser-card assembly 180
  - adapter 185, 187–188
  - air baffle 147
  - an optical drive 161
  - battery, system 247
  - components 131
  - dedicated slotless RAID controller 183
  - DIMM 165
  - EIA 206
  - fan cage assembly 172
  - front USB assembly 151
  - heat sink 265
  - heat-sink retention module 280
  - hot-swap ac power supply 228
  - hot-swap dc power supply 233
  - hot-swap drive backplane 241, 243

- hot-swap fan 174
- hot-swap hard disk drive 153
- LCD system information display panel 253
- lightpath LCD operation panel assembly 176
- media cage 176
- memory module 165
- microprocessor 265
- operator information panel 262
- optical drive cable 159
- power paddle module 149
- RAID adapter remote battery 197
- rear two hard-disk-drive kit 200
- SD adapter 252
- security bezel 264
- simple-swap drive backplate assembly 241, 243
- simple-swap hard disk drives 156
- system board 281
- top cover 144
- USB hypervisor flash device 246
- Replaceable server components 111
- replacing
  - adapter 189, 195
    - rear two hard-disk-drive kit 196
  - air baffle 148
  - battery, system 250
  - components 131
  - dedicated slotless RAID controller 184
  - DIMM 171
  - EIA 216
  - fan cage assembly 173
  - front USB assembly 152
  - heat sink 270
  - heat-sink retention module 280
  - hot-swap ac power supply 230
  - hot-swap dc power supply 236
  - hot-swap drive backplane 242
  - hot-swap fan 175
  - hot-swap hard disk drive 154
  - LCD system information display panel 256
  - microprocessor 270
  - operator information panel 263
  - Optical drive 162
  - optical drive cable 160
  - power paddle module 150
  - RAID adapter remote battery 198
  - rear two hard-disk-drive kit 201
  - riser-card assembly 181
  - SD adapter 252
  - security bezel 265
  - simple-swap drive backplate assembly 244
  - simple-swap hard disk drives 157
  - structural parts 144
  - system board 284
  - Tier 1 CRUs 147
  - Tier 2 CRUs 265
  - top cover 146
  - USB hypervisor flash device 246
- returning
  - component 131
  - device 131
- riser-card assembly
  - LEDs 35
  - removing 180
  - replacing 181
  - riser-card assembly 181
- routing
  - the configuration cable 132, 134, 137, 141, 143
  - the hardware RAID cable 132, 134, 137, 141, 143
  - the power cable 132, 134, 137, 141, 143
- RTMM heartbeat
  - LED 72
- Russia Class A electronic emission statement 1158

## S

- safety v
- Safety Information 6
- safety statements v-vi
- SD adapter
  - removing 252
- security bezel
  - removing 264
  - replacing 265
- security bezel, removing 264
- security bezel, replacing 265
- sending diagnostic data 311, 1150
- serial number 1
  - location 106
- serial port problems 99
- server
  - offerings 13
  - power features 39
  - turning off 40
  - turning on 39
- server , backup firmware
  - starting 51
- server components 27, 111
- server configuration
  - updating 310
- server controls, LEDs, and power 18
- server firmware, recovering 107
- server shutdown 40
- ServeRAID support 13
- ServerGuide 13
  - features 45
  - NOS installation 46
  - setup 46
  - Setup and Installation CD 43
  - using 45
- ServerGuide CD 1
- service and support
  - before you call 1149
  - hardware 1151
  - software 1151
- service bulletins 65
- serviceability, server 16
- Setup utility
  - menu choices 47
- Setup Utility 43-44
  - starting 47
  - using 47
- shutting down the server 40
- simple-swap drive backplate assembly
  - hot-swap drive backplane
    - replacing 244
  - removing 241, 243
  - replacing 244
  - hot-swap drive backplane 244
- simple-swap hard disk drives
  - removing 156
  - replacing 157
- size 6
- slot connectors
  - PCI riser-card 33
- SMP 13
- software
  - requirements 4
- software problems 101
- software service and support telephone numbers 1151
- specifications 6, 12
- starting
  - Setup Utility 47
  - the backup firmware 51
- statements and notices 6
- static-sensitive devices
  - handling 289
- structural parts 127
- support web page, custom 1150

- switches
  - system board 30
- symmetric multiprocessing 13
- system
  - error LED front 20
  - locator LED, front 20
- System
  - information LED 20
- system board
  - buttons 30
  - external connectors 28
  - internal connectors 28
  - jumpers 30
  - LEDs 33
  - removing 281
  - replacing 284
  - switches 30
- system board optional devices connectors 29
- system event log 74
- system pulse LEDs 72
- system reliability guidelines 288
- system-event log 73
- system-event log, assertion event 73
- system-event log, deassertion event 73
- systems management 13

## T

- Taiwan BSMI RoHS declaration 1159
- Taiwan Class A electronic emission statement 1158
- Taiwan product service 1151
- telecommunication regulatory statement 1155
- telephone numbers 1151
- test log, viewing 77
- thermal grease 279
- tools, call home 78
- tools, diagnostic 67
- top cover
  - removing 144
  - replacing 146
- trademarks 1154
- troubleshooting 63
  - symptom 78
- turning off the server 40
- turning on the server 39

## U

- UEFI
  - boot recovery jumper 107
- undetermined problems 105
- undocumented problems 65
- United States FCC Class A notice 1156
- UpdateXpress 43, 51
- updating
  - DMI/SMBIOS 59
  - firmware 43
  - Lenovo XClarity Administrator 57
  - server configuration 310
  - Universal Unique Identifier (UUID) 57
- USB
  - connector 18
- USB connector problems 101
- USB hypervisor flash device
  - removing 246
  - replacing 246
- using
  - embedded hypervisor 55
  - integrated management module 51
  - Setup Utility 47
  - the remote presence feature 53
- utility, Setup 44

starting 47  
using 47

## V

video connector  
  front 18  
viewing event log 74  
VMware Hypervisor support 44

## W

Wake on LAN feature 39  
weight 6  
what the server offers 13  
working inside the server  
  power on 288

## X

X-Architecture technology 13





**Lenovo**<sup>™</sup>